

ISO 9001 **AV** *AUTOMATIC VALVE*

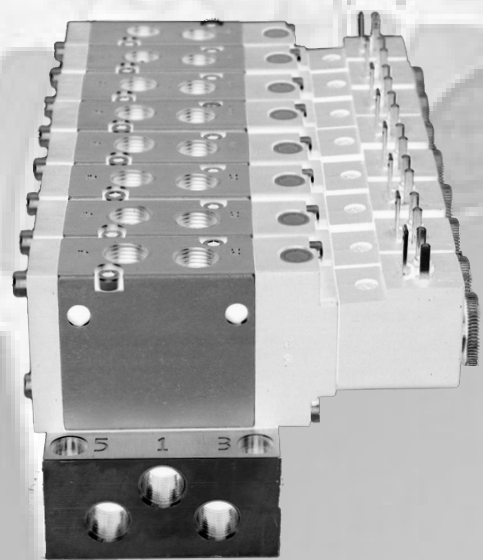

World Class Pneumatic Solutions

AV AUTOMATIC VALVE

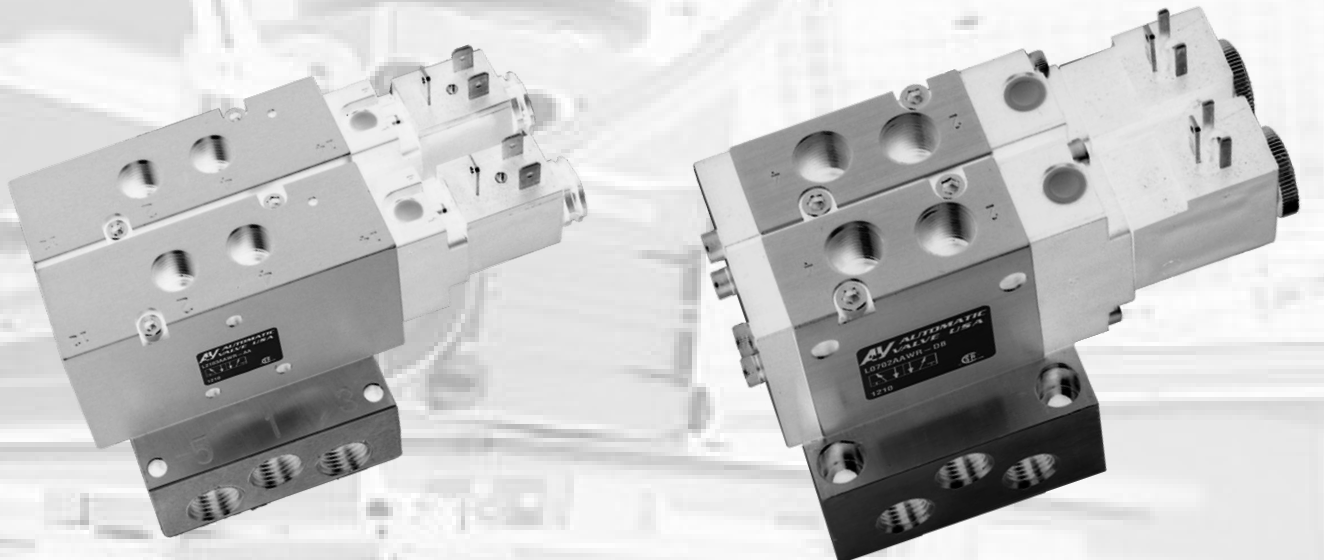

Top Mount Spool Valves

	Page
Design Features	C2
Specifications	C3
Model Numbers	C3
Weather-Proof & Explosion-Proof	C4-C5
Air Pilot	C6-C7
Manual	C8-C10
Manifolds	C11-C12
Options	C13
Configuration Example	C14
Electrical Information	C15
Service Information	C16

5/2



5/3

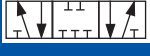

Top Mount Spool Valves Design Features

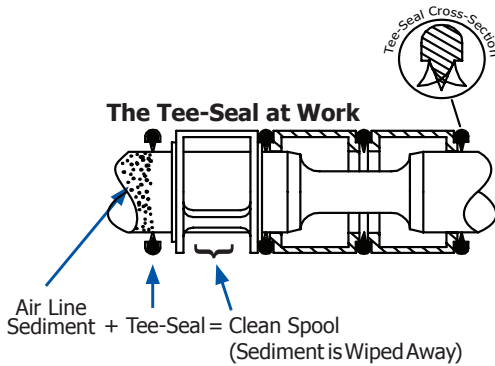
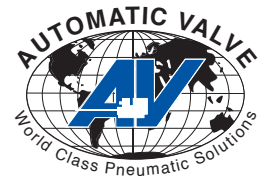

Valves

- Balanced spool construction allows ports to be plugged for 2 or 3 way function, or restricted for inexpensive cylinder exhaust speed control. For selector or dual pressure applications, consult the Factory.
- Manifold or line mount: flexible, efficient.
- Solid manifold construction for rugged, reliable performance.
- Specific application needs? Consult the factory. We will build it for you.

Tapered Tee-Seal Eats Dirt

- Bidirectional tapered Tee-Seal eliminates sticking problems.
 - Flexes to clean spool
 - Mechanically Locked
 - No Spiral Twist
 - No Extrusion
 - Air Line Sediment is Wiped Away.
- Tested tough and proven reliable according to SAE specifications: Rust and water injected every 864,000 cycles for 20 million cycles.



Solenoid ... Guaranteed Against Burnout

- Three-way pilot uses full air line pressure to shift the valve.
- Pilot is internally supplied when the pressure at port one is 35 to 150 PSIG (240 to 1030 kPa).
- Coil is hermetically sealed as an integral watertight molded unit.
- Intrinsically-safe and explosion-proof versions available.
- Push Non-Locking Override is standard. (Extended Turn and Turn-Locking available)



Products Certified To:

- CSA - (C22.2 and UL STD 429)
- Factory Mutual - Explosion Proof Environments
- ATEX - Explosion Proof Environments
- CE - EMF and Low Voltage Directives



Top Mount Spool Valves Specs & Model Numbers

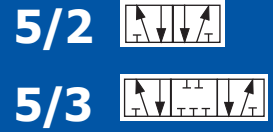

Specifications

Valve Operation		Valve Operation	
<p>5/2 SINGLE De-Energized: Pressure from Port 1 to Port 2 Exhaust from Port 4 to Port 5 Energized: Pressure from Port 1 to Port 4 Exhaust from Port 2 to Port 3</p>		<p>5/3 EXHAUST Maintained Energized 12: Pressure from Port 1 to Port 2 Exhaust from Port 4 to Port 5 De-Energized: Port 2 open to Port 3, Port 4 open to Port 5 Port 1 Blocked Maintained Energized 14: Pressure from Port 1 to Port 4 Exhaust from Port 2 to Port 3</p>	
<p>5/2 DOUBLE Momentarily Energized 12: Pressure from Port 1 to Port 2 Exhaust from Port 4 to Port 5 Momentarily Energized 14: Pressure from Port 1 to Port 4 Exhaust from Port 2 to Port 3</p>		<p>5/3 PRESSURE Maintained Energized 12: Pressure from Port 1 to Port 2 Exhaust from Port 4 to Port 5 De-Energized: Port 1 open to Ports 2 & 4; Ports 3 & 5 Blocked Maintained Energized 14: Pressure from Port 1 to Port 4 Exhaust from Port 2 to Port 3</p>	
Operating Temperatures 	Solenoid Pilot Operated	Treated Buna-N Seals (Treated NBR, Standard)	Fluoroelastomer Seals (FPM (FKM), Standard - L05; Option A on L21 & L45)
	Standard High Temp Coil (Option CT)	-18°C to +50°C (0°F to +123°F) -18°C to +82°C (0°F to +180°F)	-18°C to +50°C (0°F to +123°F) -18°C to +82°C (0°F to +180°F)
Operating Pressures 	Solenoid Pilot Operated	Inlet Port	External Pilot Port
	Standard 2 Position	L05: 345 - 1030 kPa (50 - 150 PSIG) L21 & L45: 240 - 1030 kPa (35 - 150 PSIG) * L45 requires a min 1/2" ID inlet	-
	Standard 3 Position External Pilot (Option B)	345 - 1030 kPa (50 - 150PSIG) Vacuum - 240 kPa (Vacuum - 35 PSIG)	- 240 - 1030 kPa (35 - 150 PSIG)
Filtration & Lubrication 	Media - Air Or Inert Gas Air Line Lubrication of Automatic Valve products is not required, but is recommended to maximize service life. Oils should be compatible with seal material, have an ISO 32 viscosity, and have an aniline range between 82°C (180°F) and 99°C (210°F). Filter to 50 microns or better. For temperatures below 40°F, air must be dry to prevent formation of ice. Refer to the Maintenance section of this catalog for recommended lubricants.		

Model Numbers

Series	Body Type	Port Size	Function	Body Design	Operator 1	Center Operator	Operator 2	Voltage ³	Options*
L05	0 Inline, Manifold	2 1/8	A 4 Way 2 Position	A	A Air Pilot	N/A	A Air Pilot	-AA 110/50, 120/60	B External Pilot Connection
				B	I Palm Button W Weather-Proof Solenoid		R 2 Pos'n Spring W Weather-Proof Solenoid	-AB 220/50, 240/60, 125VDC	
L07	1 Manifold	2 1/8 3 1/4	A 4 Way 2 Position B 4 Way 2 Position ¹	A Single B Double	A Air Pilot	D 3 Pos'n Spring	A Air Pilot	-DA 22/50, 24/60, 12VDC -DB 24VDC	A Fluoroelastomer Seals
L21	0 Inline, Manifold	3 1/4	C 4 Way 3 Position Block		F Hand Lever - Line G Hand Lever - Manifold		C 3 Position Spring Manual		B External Pilot Connection
L45	0 Inline, Manifold	5 1/2	D 4 Way 3 Position Exhaust	I Palm Button	I Palm Button	M 2 Position Detent Manual	C Conduit Coil	CT Conduit Coil High Temp	
			E 4 Way 3 Position Pressure	J Cam	J Cam	N 3 Position Detent Manual	D Dustproof		
				K Foot Pedal L Foot Treadle V Intrinsically-Safe Solenoid ² (24VDC only) W Weather-Proof Solenoid	R 2 Position Spring V Intrinsically-Safe Solenoid ² (24VDC only) W Weather-Proof Solenoid	G 18" Flying Leads L Low Watt Coil (2.5 Watts) LL Lowest Watt Coil (0.7 Watts) S 303 Stainless Steel Body (L45 only) SS 316 Stainless Steel Body (L45 only) W G (BSPP)Threads Y Explosion-Proof Coil (CSA,FM) Z Explosion-Proof Coil (ATEX)			
								1 Push Turn-Locking Override 2 Extended Turn-Locking Override 4 No Override	

* Not all Options are available for all models. Refer to "Options" at the end of this Section for additional information.
¹ Use varies. Consult the Factory for details. ² Can not be used on a manifold. ³ Consult the Factory for additional voltages.

5/2 

5/3 

Top Mount Spool Valves

Weather-Proof & Explosion-Proof



Single



L0502AAWR



L0712AAWR
(manifold mounted only)



L2103AAWR



L4505AAWR

Double



L0502ABWW



L0712DBWW
(manifold mounted only)



L2103ABWW



L4505ABWW

Model Numbers

Series	Port Size	Flow l/min (Cv)		5/2		5/3			Mat'l		Wt Kg (lb)
		5/2	5/3	Single	Double	Block	Exhaust	Pressure	Body	Seal	
L05	1/8	390 (0.4)	-	L0502AAWR-**	L0502ABWW-**	-	-	-	Aluminum	FPM (FKM)	0,2 (0.4)
L07	1/8	690 (0.7)	538 (0.5)	L0712AAWR-**	L0712ABWW-**	L0712CBWDW-**	L0712DBWDW-**	L0712EBWDW-**		NBR	0,3 (0.6)
	1/4			L0713AAWR-**	L0713ABWW-**	L0713CBWDW-**	L0713DBWDW-**	L0713EBWDW-**			
L21	1/4	1770 (1.8)	1381 (1.4)	L2103AAWR-**	L2103ABWW-**	L2103CBWDW-**	L2103DBWDW-**	L2103EBWDW-**		0,5 (1.1)	
L45	1/2	4755 (4.8)	3709 (3.7)	L4505AAWR-**	L4505ABWW-**	L4505CBWDW-**	L4505DBWDW-**	L4505EBWDW-**	0,7 (1.6)		

** = Coil Voltage Code. Coils also sold separately. Refer to "Electrical Information" at the end of this Section for additional information.

Dimensional Information

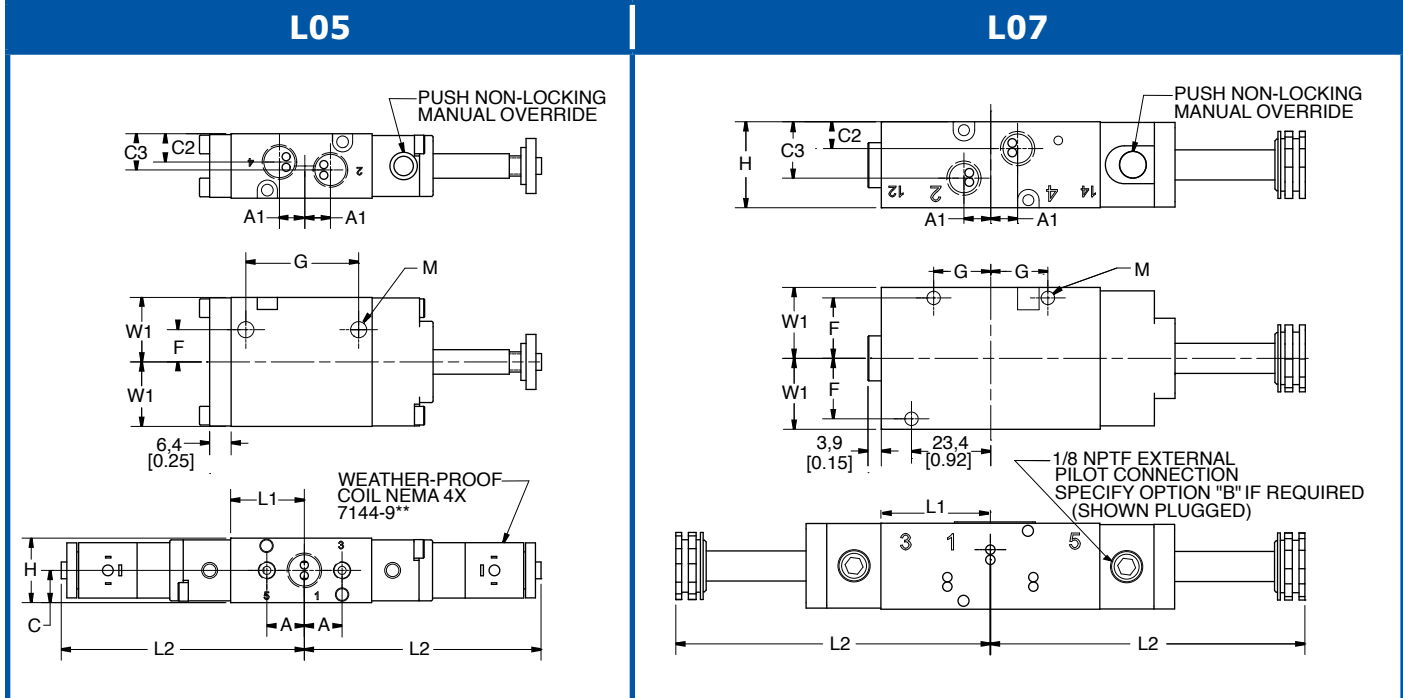

L21 & L45

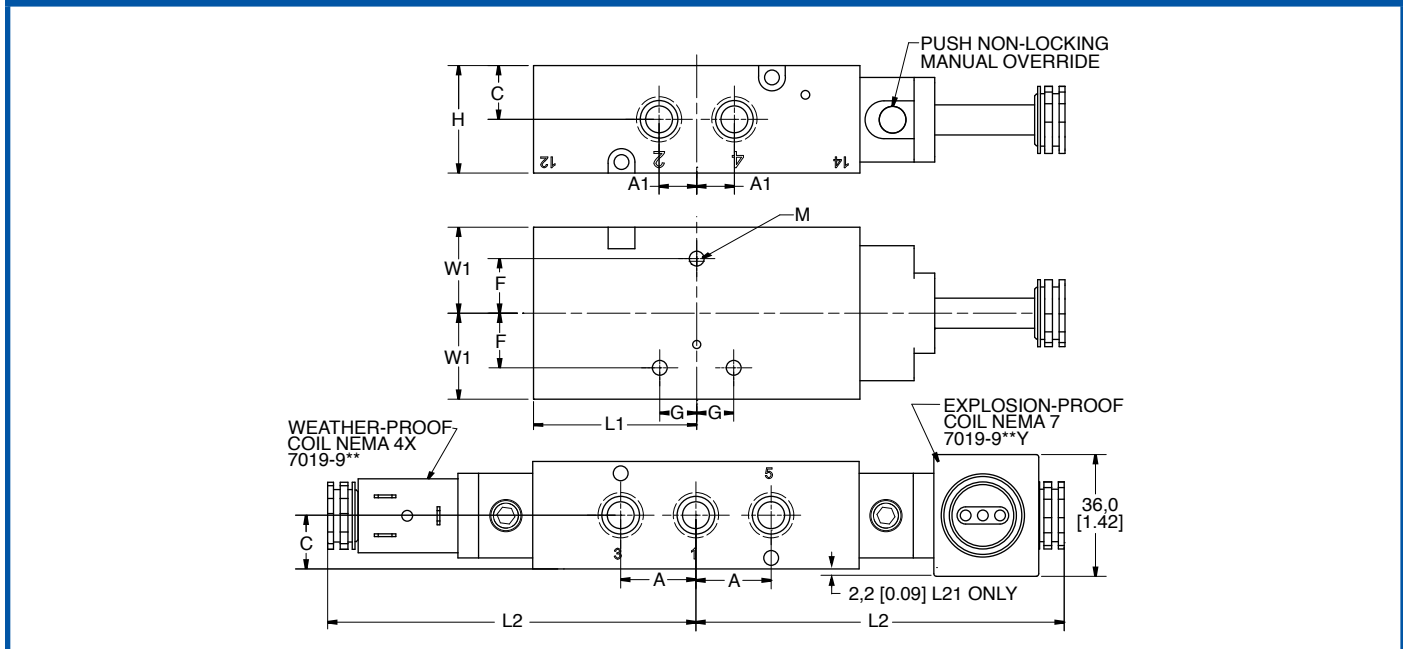

Series	A	A1	C	C2	C3	F	G	H	L1	L2	M	W1
L05	11,1 0.44	7,3 0.29	9,6 0.38	8,3 0.38	10,6 0.42	9,6 0.38	33,2 1.31	19,1 0.75	21,3 0.84	69,0 2.72	4,5 0.18	19,1 0.75
L07	-	7,9 0.31	-	7,9 0.31	16,9 0.66	16,1 0.64	10,9 0.43	25,4 1.0	32,3 1.27	92,7 3.65	4,4 0.17	24,6 0.97
L21	22,2 0.88	11,1 0.44	16,5 0.65	-	-	16,1 0.64	10,9 0.43	31,7 1.25	48,2 1.90	109 4.28	4,4 0.17	24,4 1.00
L45	34,5 1.36	34,5 1.36	21,0 0.83	-	-	19,0 0.75	17,0 0.68	42,2 1.66	69,0 2.72	129 5.07	6,7 0.27	31,8 1.25

Units of Measure: Top - mm, Bottom - inches

5/2



5/3



Top Mount Spool Valves

Air Pilot

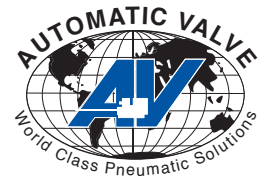

Single



L0502AAAR



L0712AAAR
(manifold mounted only)



L2103AAAR



L4505AAAR

Double



L0502ABAA



L0713ABAA
(manifold mounted only)



L2103ABAA



L4505ABAA

Model Numbers

Series	Port Size	Flow l/min (Cv)		5/2		5/3			Material		Wt Kg (lb)	
		5/2	5/3	Single	Double	Block	Exhaust	Pressure	Body	Seal		
L05	1/8	390 (0.4)	304 (0.3)	L0502AAAR	L0502ABAA	-	-	-	Aluminum	NBR	FPM (FKM)	0,2 (0.4)
L07	1/8	690 (0.7)	538 (0.5)	L0712AAAR	L0712ABAA	L0712CBADA	L0712DBADA	L0712EBADA				
	1/4			L0713AAAR	L0713ABAA	L0713CBADA	L0713DBADA	L0713EBADA				
L21	1/4	1770 (1.8)	1381 (1.4)	L2103AAAR	L2103ABAA	L2103CBADA	L2103DBADA	L2103EBADA			0,5 (1.1)	
L45	1/2	4755 (4.8)	3709 (3.7)	L4505AAAR	L4505ABAA	L4505CBADA	L4505DBADA	L4505EBADA	0,8 (1.7)			

Dimensional Information

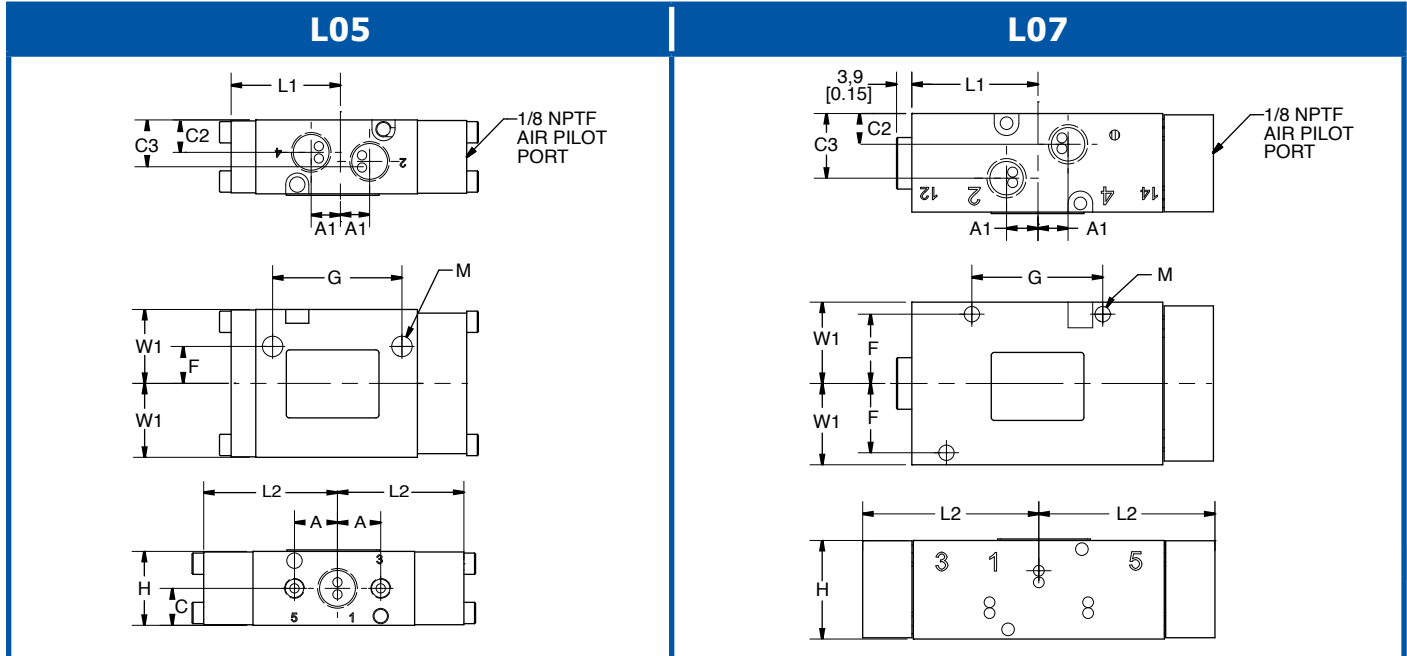

L21 & L45

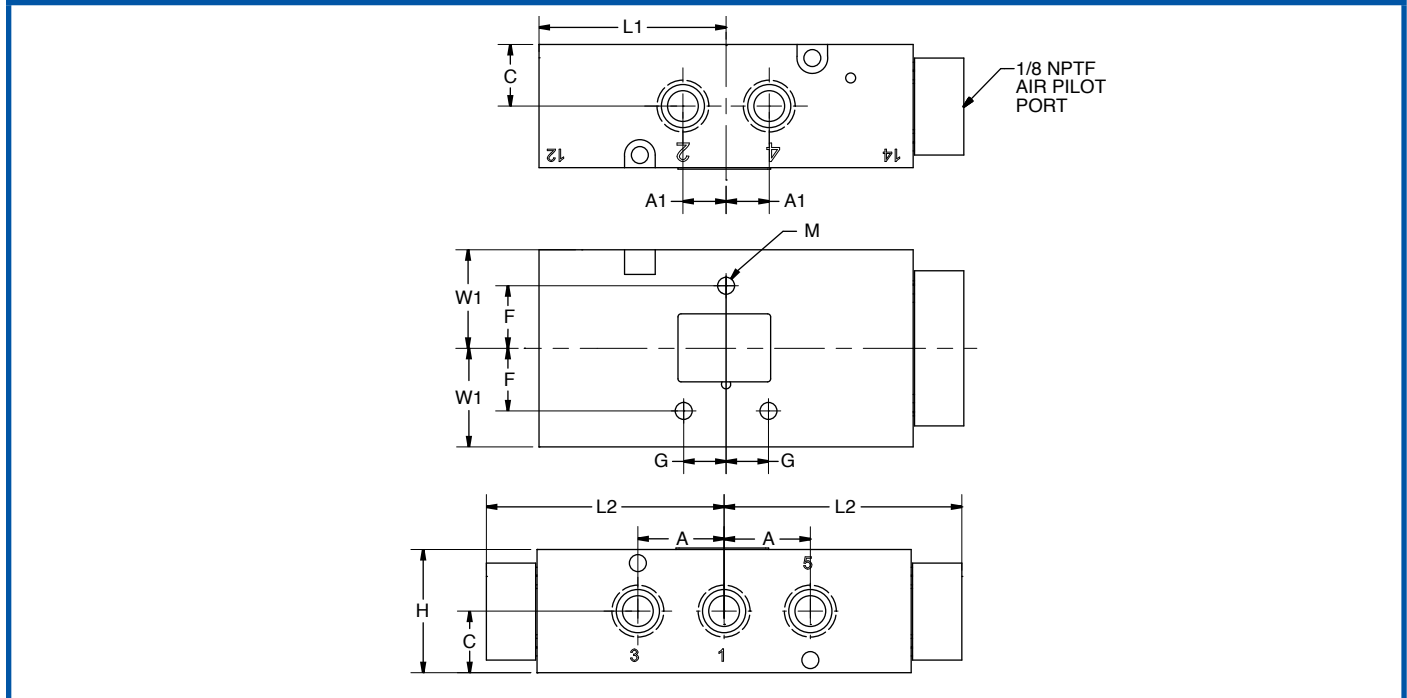

Series	A	A1	C	C2	C3	F	G	H	L1	L2	M	W1
L05	11,1 0.44	7,3 0.29	9,6 0.38	8,3 0.38	10,6 0.42	9,6 0.38	33,2 1.31	19,1 0.75	28,2 1.11	34,5 1.36	4,5 0.18	19,1 0.75
L07	-	7,9 0.31	-	7,9 0.31	16,9 0.66	18,3 0.72	33,5 1.32	25,4 1.00	32,3 1.27	45,0 1.77	4,0 0.16	21,0 0.83
L21	22,2 0.88	11,1 0.44	16,5 0.65	-	-	16,1 0.64	10,9 0.43	31,7 1.25	48,2 1.90	61,0 2.40	4,4 0.17	24,4 1.00
L45	34,5 1.36	17,3 0.68	21,0 0.83	-	-	19,0 0.75	17,3 0.68	42,2 1.66	69,0 2.72	88,9 3.50	6,7 0.27	31,8 1.25

Units of Measure: Top - mm, Bottom - inches

5/2



Top Mount Spool Valves Manual



5/2 Palm Button



L0502AAIR



L2103BAIM

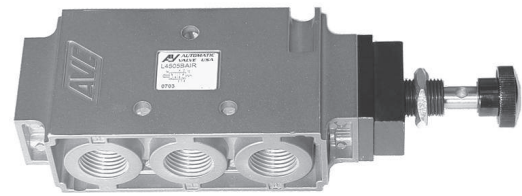

L4505BAIR

5/2 Hand Lever - Line Mounted

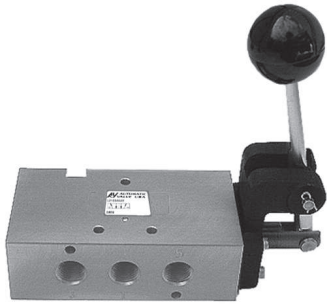

L2103BAFM

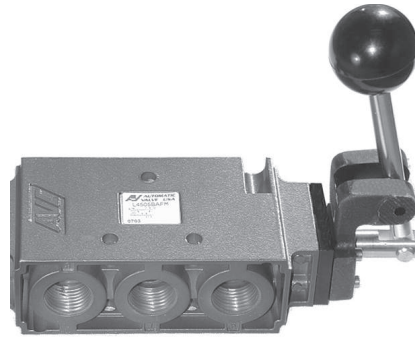

L4505BAFM

5/2 Hand Lever - Manifold Mounted

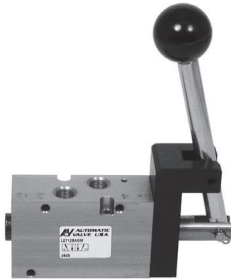

L0712BAGM

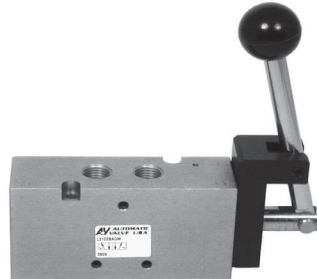

L2103BAGM



L4505BAGM

Model Numbers

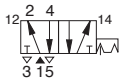
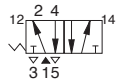
Series	Port Size	Flow (5/2) l/min (Cv)	Operator	5/2 (4 Way 2 Position)		Material		Wt kg (lb)
				Detented	Spring Return	Body	Seal	
								
L05	1/8	390 (0.4)	Palm Button	-	-	Aluminum	FPM (FKM)	12 (0.4)
L07	1/8	690 (0.7)	Hand Lever Manifold Mounted	-	-		NBR	0,3 (0.6)
	1/4			L0713BAGM	L0713AAGR			
L21	1/4	1770 (1.8)	Hand Lever Line Mounted	L2103BAFM	L2103AAFR		NBR	0,5 (1.1)
			Hand Lever Manifold Mounted	L2103BAGM	L2103AAGR			
			Palm Button	L2103BAIM	L2103AAIR			
L45	1/2	4755 (4.8)	Hand Lever Line Mounted	L4505BAFM	L4505BAFR		NBR	0,96 (2.1)
			Hand Lever Manifold Mounted	L4505BAGM	L4505BAGR			
			Palm Button	L4505BAIM	L4505BAIR			

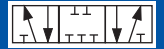

5/3 Hand Lever - Line Mounted



5/3 Palm Button

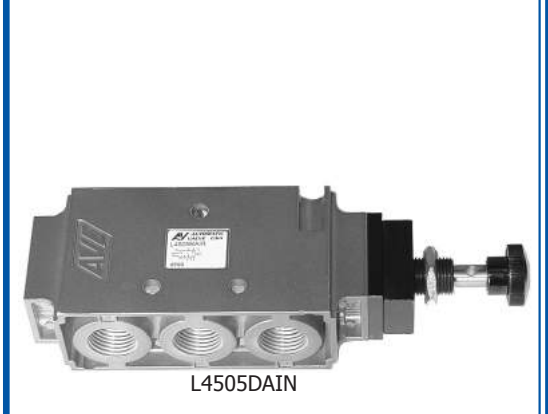

5/3 Hand Lever - Manifold Mounted



Model Numbers

Series	Port Size	Flow (5/3) l/min (Cv)	Operator	5/3 (4 Way 3 Position)						Body Material	Seal Material	Weight Kg (lb)		
				Detented			Spring Center							
				Block	Exhaust	Pressure	Block	Exhaust	Pressure					
L07	1/8	0.5	Hand Lever Manifold Mounted							Aluminum	NBR	0,3 (0.6)		
	1/4	538 (0.5)		-	-	-	-	-	-					
L21	1/4	1381 (1.4)	Hand Lever Line Mounted	L2103CAFN	L2103DAFN	L2103EAFN	L2103CBFC	L2103DBFC	L2103EBFC			Aluminum	NBR	0,5 (1.1)
			Hand Lever Manifold Mounted	L2103CAGN	L2103DAGN	L2103EAGN	L2103CBGC	L2103DBGC	L2103EBGC					
			Palm Button	-	-	-	-	-	-					
L45	1/2	3709 (3.7)	Hand Lever Line Mounted	L4505CAFN	L4505DAFN	L4505EAFN	L4505CBFC	L4505DBFC	L4505EBFC			Aluminum	NBR	1,0 (2.1)
			Hand Lever Manifold Mounted	L4505CAGN	L4505DAGN	L4505EAGN	L4505CBGC	L4505DBGC	L4505EBGC					
			Palm Button	L4505CAIN	L4505DAIN	L4505EAIN	L4505CBIC	L4505DBIC	L4505EBIC					

5/2 

5/3 

Top Mount Spool Valves Manual

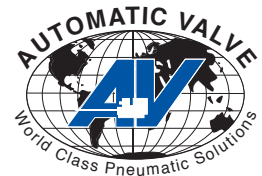

Dimensional Information

Hand Lever

Inline

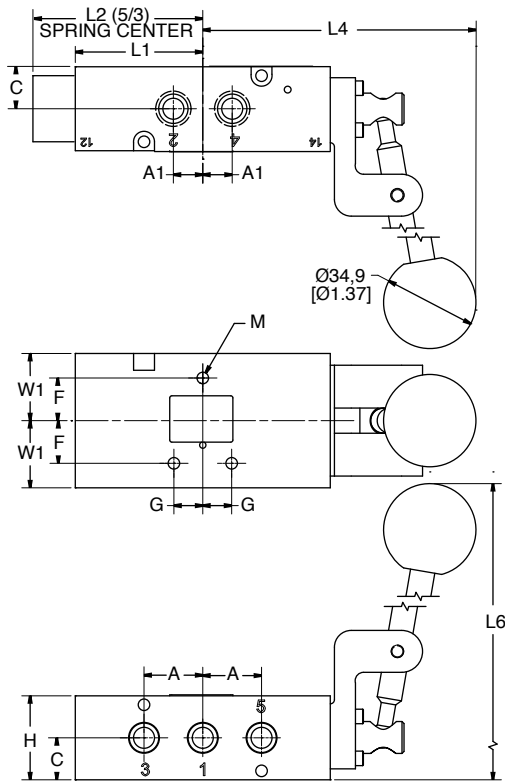

Manifold Mount

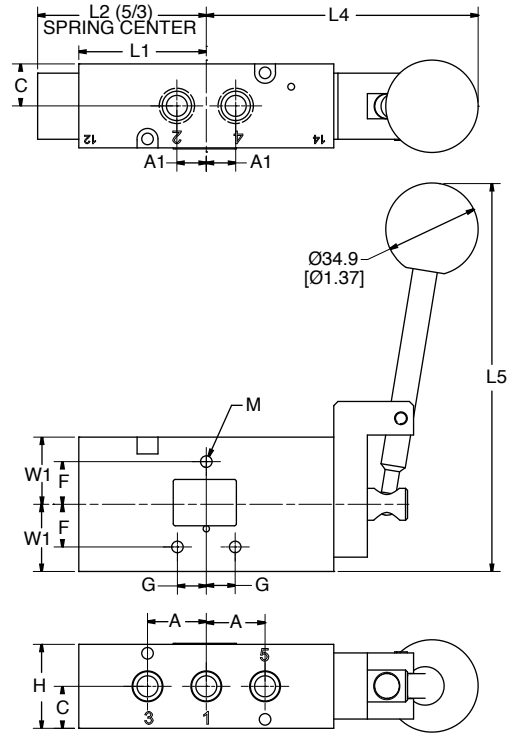

Palm Button

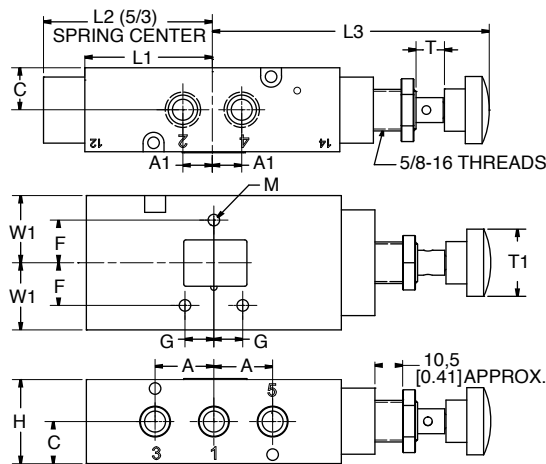

Series	A	A1	C	F	G	H	L1	L2	L3	L4	L5	L6	M	T	T1	W1
L05	11,1 0.44	7,3 0.29	9,6 0.38	9,6 0.38	33,2 1.31	19,1 0.75	28,2 1.11	-	42,2 1.66	-	-	-	4,5 0.18	4,8 0.19	16,0 0.63	19,1 0.75
L07		7,9 0.31	-	18,3 0.72	16,9 0.66	25,4 1.00	32,3 1.27	48,0 1.89	89,9 3.54	89,4 3.52	133 5.24	133 5.24	4,0 0.16	6,4 0.25	25,4 1.00	21,0 0.83
L21	22,2 0.88	11,1 0.44	16,0 0.63	16,1 0.64	10,9 0.43	31,7 1.25	48,2 1.90	64,0 2.52	106 4.16	105 4.14	137 5.39	138 5.41	4,4 0.17	9,5 0.38	25,4 1.00	25,4 1.00
L45	34,5 1.36	34,5 1.36	21,0 0.83	19,0 0.75	17,3 0.68	42,2 1.66	69,0 2.72	99,3 3.91	127 5.00	126 4.96	143 5.64	143 5.63	6,7 0.27	12,7 0.50	25,4 1.00	31,8 1.25

Units of Measure: Top - mm, Bottom - inches

Top Mount Spool Valves Manifolds

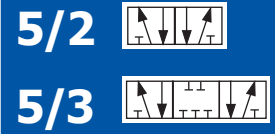

L05 Manifold

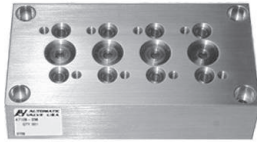

A7204-014

L21 Manifold

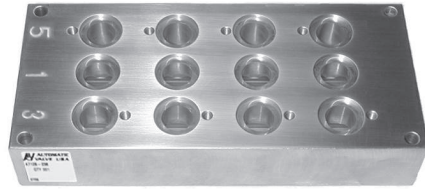

A8023-014

L07 Manifold

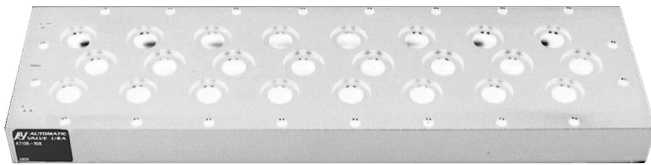

A7106-608

L45 Manifold

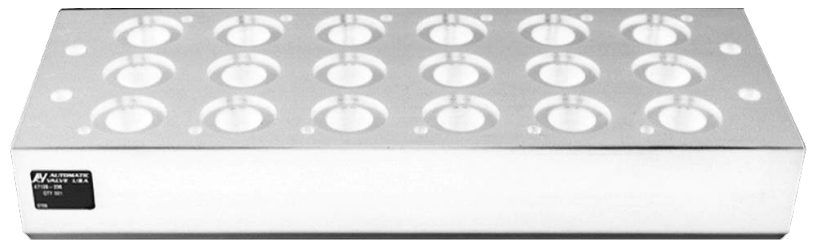

A7128-236

Features

- Common inlet and common exhaust ports.
- Valve cylinder ports face up.
- Mount through the valve, from the top.
- Seals and mounting hardware included.

Model Numbers

Series	Manifold				Accessories	
	Number of Stations	Model Number	Port 3, 1, & 5	Weight Kg (lb)	Blocking Disk	Blank Station Cover
L05	2	A7204-012	1/8	0,2 (0.5)	A7204-039	A7204-027
	4	A7204-014		0,3 (0.7)		
	6	A7204-016		0,4 (1.1)		
	8	A7204-018		0,6 (1.4)		
	10	A7204-010		0,7 (1.7)		
	12	A7204-112		0,9 (2.1)		
	14	A7204-114	1,1 (2.5)			
L07	2	A7106-602	1/4	0,2 (0.5)	A7105-202	A7106-603
	4	A7106-604		0,4 (0.8)		
	6	A7106-606		0,5 (1.1)		
	8	A7106-608		0,7 (1.4)		
	10	A7106-610		0,8 (1.8)		
	12	A7106-611		0,9 (2.1)		
L21	2	A8023-012	3/8	0,4 (0.9)	A8020-202	A8023-009
	4	A8023-014		0,9 (2.0)		
	6	A8023-016		1,3 (3.0)		
	8	A8023-018		1,8 (3.9)		
	10	A8023-010		2,2 (4.9)		
L45	2	A7128-232	3/4	1,1 (2.5)	-	A7128-229
	4	A7128-234		1,8 (4.0)		
	6	A7128-236		2,7 (5.9)		
	8	A7128-238		3,3 (7.8)		
	10	A7128-240		4,3 (9.6)		

Notes: Previous L45 manifolds (A7127-***) are not compatible with the current L45 valve.
Above manifolds are not compatible with bar stock L45 series valves. Consult the factory for further details.

5/2



5/3



Top Mount Spool Valves Manifolds

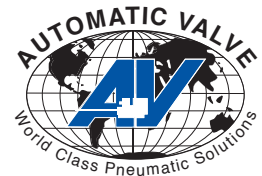

Dimensional Information

L05 Manifolds

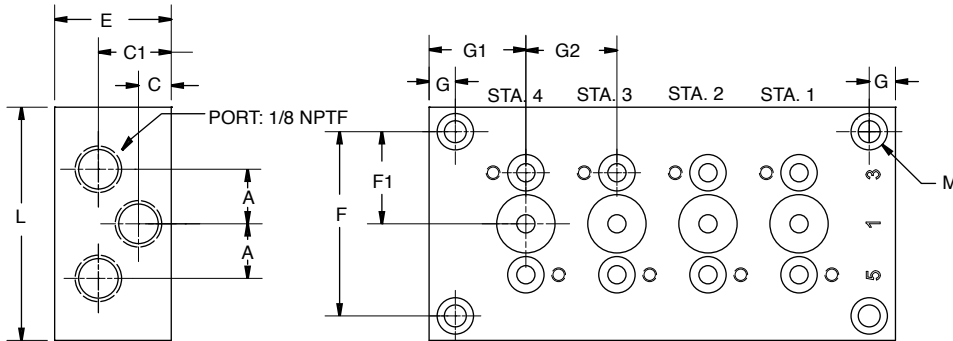

L07 Manifolds

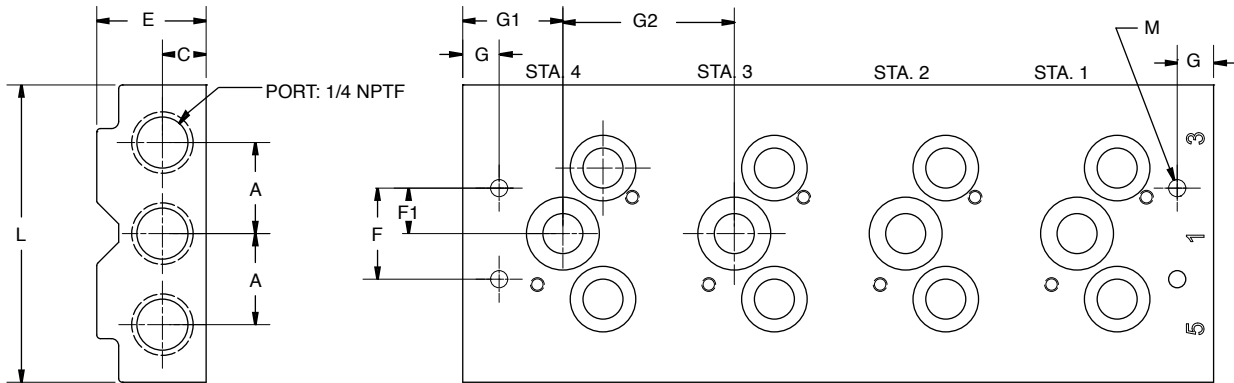

L21 & L45 Manifolds

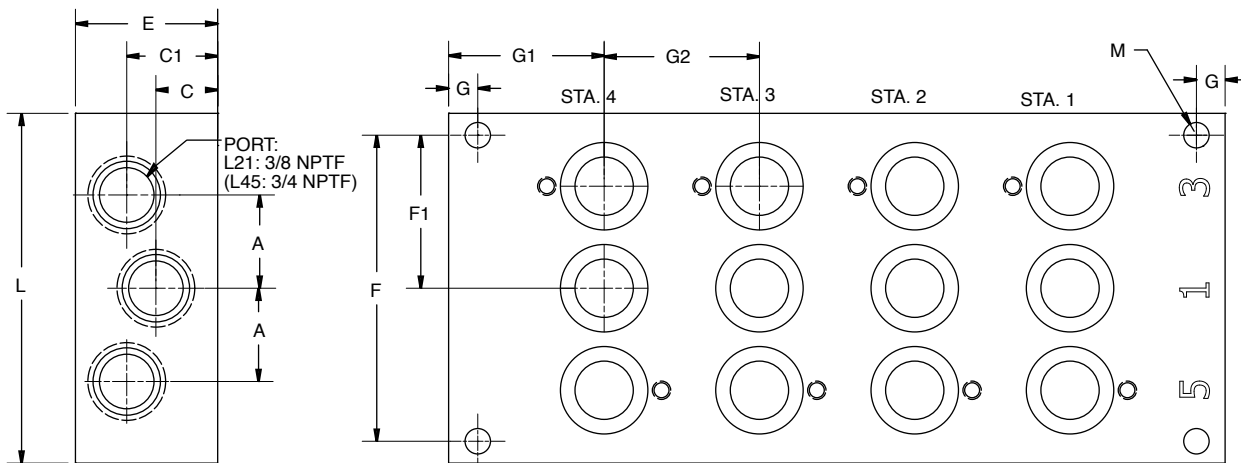

Series	A	C	C1	E	F	F1	G	G1	G2	L	M
L05	11,9 0.47	7,11 0.28	15,8 0.62	25,4 1.00	40,1 1.58	20,0 0.79	5,8 0.23	21,1 0.83	19,8 0.78	50,8 2.00	4,5 0.18
L07	12,2 0.78	9,6 0.38	-	23,9 0.94	12,2 0.78	9,91 0.38	7,87 0.31	21,8 0.86	37,3 1.47	64,8 2.55	3,81 0.15
L21	20,3 0.80	13,4 0.53	19,8 0.78	30,9 1.22	66,5 2.62	33,3 1.31	6,4 0.25	33,8 1.33	33,8 1.33	76,2 3.00	5,6 0.22
L45	40,1 1.58	19,3 0.76	30,0 1.18	50,8 2.00	38,1 1.50	19,1 0.75	13,9 0.55	43,4 1.71	43,4 1.71	117 4.60	8,6 0.34

Units of Measure: Top - mm, Bottom - inches

L05 Options (Add the suffix to the end of the model number in alpha-numeric order)

Suffix	Option	Description
B	External Pilot	For solenoid applications where the pressure to port one is less than 35 PSIG (2 BAR). If an externally piloted L05 is required, it must be ordered as such. Field conversion is not applicable.

L07, L21, L45 Options (Add the suffix to the end of the model number in alpha-numeric order)

Suffix	Option	Description
A	Fluoroelastomer Seals	For applications where fluid media or ambient conditions are not compatible with nitrile seals. <i>Note: Fluorocarbon seals do not increase the effective temperature range of the valve. For high temperature applications, consult the factory.</i>
B	External Pilot	For solenoid applications where the pressure to port one is less than 35 PSIG (2 BAR). See example below for field conversion of the L07, L21 and L45.
		<p style="text-align: center;">Field Conversion for the L07, L21 & L45</p> <ul style="list-style-type: none"> Remove solenoid and cap from the valve body. Rotate the gasket 180° so that the internal pilot hole in the valve body is covered by the gasket. Refasten the gasket, cap and solenoid to the valve body. Make sure the gasket completely covers the internal pilot hole before tightening the M3 screws. Torque to 1,02 N-m (9 in-lbs) ±10%. Remove the 1/8 NPTF pipe plug from the cap and make the external pilot connection.
C	Conduit Coil	Refer to the "Electrical Information" page in this section for details.
CT	Conduit Coil High Temperature	With 30" Leads. Refer to the "Electrical Information" page in this section for details .
D	Dustproof	For applications in extremely dusty and contaminated environments. Vent ports are plugged and spring pad breather vent is eliminated.
G	Coil With 18" Leads	Refer to the "Electrical Information" page in this section for details.
L	Low Watt Coil	Power Consumption = 2.5 Watts. Standard as Push Non-Locking Override. Also available with Option 2, Extended Turn-Locking Override.
LL	Lowest Watt Coil	Power Consumption = 0.7 Watts. Standard as Extended Turn-Locking Override.
S	303 Stainless Steel	303 Stainless Steel body, all other external parts are corrosion resistant; for corrosive environment applications (L45 only).
SS	316 Stainless Steel	316 Stainless Steel body, all other external parts are corrosion resistant; for corrosive environment applications (L45 only).
W	G Threads	All ports tapped to metric "G" standard.
Y	Explosion-Proof Coil (CSA, FM)	Refer to the "Electrical Information" page in this section for details.
Z	Explosion-Proof Coil (Atex, PTB)	Refer to the "Electrical Information" page in this section for details.
1	Push Turn-Locking Override	Solenoid cap provides an override that is pushed in and turned to actuate & lock in the "on" position.
2	Extended Turn-Locking Override	Solenoid cap provides an extended override that is turned to lock in the "on" position.
4	No Override	Solenoid cap does not provide a manual override.

5/2



5/3



Top Mount Spool Valves Configuration Example

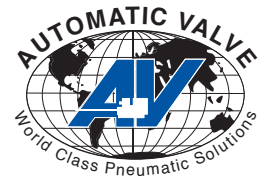

Valve With W-Solenoid Cap

+

Coil

=

Valve With Coil

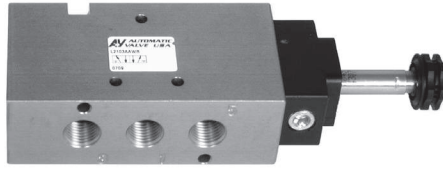

L2103AAWR

+



NEMA 4x with DIN
43650 Form B
Connection

=

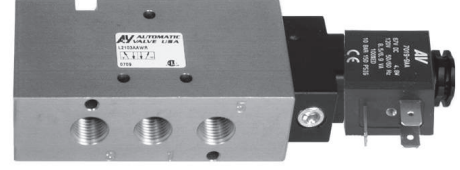

L2103AAWR-**
(L0503AAWR-** (not shown))

7019-9**
(L05: 7144-9** (not shown))

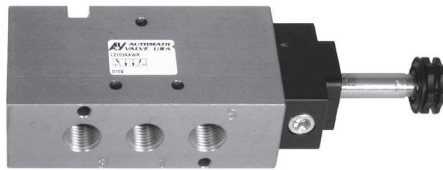

L2103AAWR

+



NEMA 4x with
18" Leads

=



L2103AAWR-**G
(L0503AAWR-**G (not shown))

7019-9**G
(L05: 7144-9** (not shown))

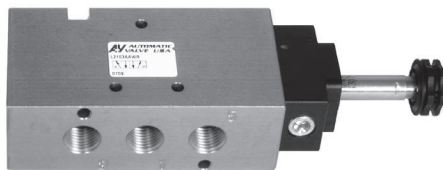

L2103AAWR

+



NEMA 4x 1/2" Conduit
with 30" Leads

=

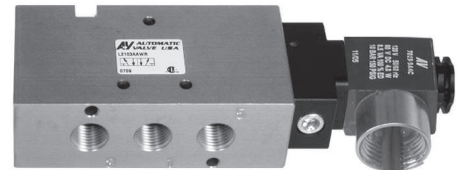

L2103AAWR-**C

7019-9**C

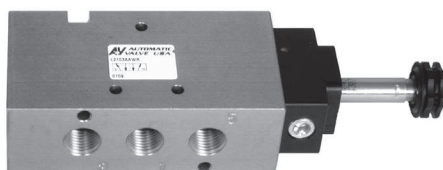

L2103AAWR

+



Explosion-Proof 1/2"
Conduit with 24" Leads

=



L2103AAWR-**Y

7019-9**Y



Top Mount Spool Valves Electrical Information

5/2

5/3

Top Mount Spool Valves

Part Numbers

Description	Series	Operator Type	Instructions	Wt. Kg(lb)	Coil Part Number **=Voltage
Weather-Proof DIN 43650C Connection NEMA 4X	L05	W	Order coil separately (specify voltage code from table below)	0,002 (0.06)	7144-9**
Weather-Proof 18" Leads NEMA 4X	L05	W	Order coil separately (specify voltage code from table below)	0,002 (0.06)	7144-9**G
Weather-Proof DIN 43650 Industrial Form B Connection NEMA 4X	L07 L21 L45	W	Order coil separately (specify voltage code from table below)	0,05 (0.12)	7019-9**
Weather-Proof 18" Leads NEMA 4X	L07 L21 L45	W	Order coil separately (specify voltage code from table below)	0,05 (0.12)	7019-9**G
Weather-Proof 1/2" Conduit with 30" Leads NEMA 4X	L07 L21 L45	W	Order coil separately (specify voltage code from table below)	0,05 (0.12)	7019-9**C 7019-9**CT (high temp 82°C max)
Explosion-Proof 1/2" Conduit with 24" Leads CSA & FM Approved CL. I; Zone1 ExmII T4; AExmII CL. I; Div.1; GR. A, B, C, D CL. II; GR. E, F, G CL. III T4 Ta=-20°C to +60°C NEMA 4, 4X, 7C, 7D, 9	L07 L21 L45	W	Order coil separately (specify voltage code from table below)	0,20 (0.44)	7019-9**Y
Intrinsically-Safe Strain Relief Ex ia CL. I; GR. A,B,C,D CL. II; GR.E,F,G CL. III; Div.1; T5	L07 L21 L45	V	Coil and Connector included with valve (24VDC only)	0,21 (0.46)	A7106-374-DB

A7106-374 Must be Used with an Intrinsically-Safe Barrier
For more information refer to "Intrinsic Safety" insert on Page D7.

Voltage Codes (Lower wattage options available, consult factory)

L05		Current (Amps)		Resist. (OHMS @ 25°C)	Power (AC=VA, DC=Watts)	L07, L21, L45				Resistance (OHMS @ 25°C)		Power (AC=VA, DC=Watts)	
		Inrush	Holding			Current (Amps)		Resistance (OHMS @ 25°C)		Power (AC=VA, DC=Watts)			
Operator Type:	W	W	W	W	Operator Type:	W	V	W	V	W	V	W	V
** Code	Voltage +/-10%	NEMA				** Code	Volt. +/-10%	NEMA	Ex ia	NEMA	Ex ia	NEMA	Ex ia
		4	4	4	4		4 7&V	4 7	Ex ia	4 7	Ex ia	4 7	Ex ia
DA	20/50 20/60	.10	.09	78	2.4	DA	24/50 24/60	-	.36 -	.24 -	-	32 -	-
AA	110/50 110/60	.02	.02	2310	2.4	AA	120/50 120/60	120/60	.08 .10	-.05 .05	-	840 530	-
AB	220/50 220/60	.01	.01	9515	2.4	AB	230/50 230/60	240/60	.04 .05	-.03 .03	-	3310 2345	-
DA	12VDC	.15	.15	78	2.0	DA	12VDC	12VDC	.38 .38	-.38 .38	-	32 32	-
DB	24VDC	.09	.09	283	2.0	DB	24VDC	24VDC	.20 .19	.05 .20	.19 .05	121 128	275
AB	125VDC	.02	.02	9515	2.0	AB	125VDC	-	.04 -	-	-.04 -	3310 -	-

Connectors (Not Polarity Dependent)

DIN 43650 Industrial Form B	L05 Connectors			L07, L21, L45 Connectors						
Type	Strain Relief without Cord	Light & 6' Cord		Strain Relief without Cord	1/2" Conduit without Cord	Molded with 6' Cord	Strain Relief with Light		Strain Relief with Light & 6' Cord	
		120/60 AC	24 VDC				100-240 AC 48-120 DC	6-48 AC/DC	100-240 AC 48-120 DC	6-48 AC/DC
P/N	7144-001	7144-002	7144-003	7020-001	7039-001	7020-006	7020-AA	7020-DB	7094-006	7094-007

5/2



5/3

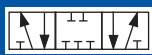

Top Mount Spool Valves

Service Information



Valve must be disconnected from all air and electrical power sources before disassembly.

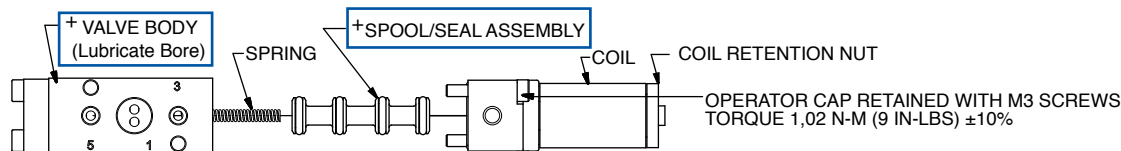

Shown: L05 Single 2 Position Valve

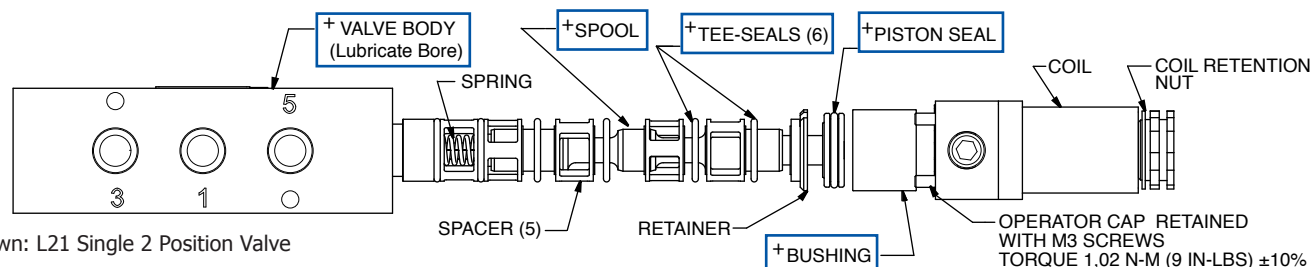

Shown: L21 Single 2 Position Valve

+ = items that must be lubricated

Service Kit Installation Instructions

- Follow appropriate lock-out/tag-out procedures. Do not attempt to service a valve, if you are not familiar with lock-out/tag-out procedures.
- Turn off electrical power to the valve.
- Remove valve from all electrical and air power sources.
- Ensure all stored air power is exhausted.
- Remove coil by first removing the coil retention nut.
- Remove operator cap by first removing socket head cap screws (L05: 2 screws) (L07, L21, & L45: 4 screws).
- Remove existing serviceable components by "pushing" internal components gently out of the valve body.
- For L05, discard spool.
- For L07, L21, or L45, clean the spool with a clean cloth.
- Discard the spring (Single Spring Return models only).
- Lubricate the designated "+" items in the above assembly drawing with a thin film of lubricant - the item should look "WET" with no excess lubricant visible.
- Replace components as shown above.
 - For L05:
 - Replace spring and spool.
 - For L07, L21 & L45:
 - Replace spring pad and spring (Single Spring Return models only).
 - Alternate Tee-seals and spacers.
 - Once all 6 Tee-seals are installed, replace the spool, retainer, bushing and piston.
- Orientate the operator cap by aligning the open end of the gasket with the pilot hole in the valve body.
- Torque cap screws into body to 1,02 N-m (9 in-lbs) ±10%. Alternate tightening of the screws, so cap "squeezes" evenly onto the body.

Air Line Lubrication of Automatic Valve products is not required, but is recommended to maximize service life. Oils should be compatible with seal material, have an ISO 32 or lighter viscosity, and have an aniline point between 82°C (180°F) and 99°C (210°F). Refer to the Maintenance Section of this catalog for recommended lubricants.

Model Numbers: Service Kits

Series	Function			
	Single		Double	
	Model Number	Contents	Model Number	Contents
L05	K-L05-SGL	Spool/Seal Assembly (1), Spring (1)	K-L05-DBL	Spool/Seal Assembly (1)
L07	K-L07-SGL	Tee-Seals (6), Piston Seal (1), Spring (1)	K-L07-DBL	Tee-Seals (6), Piston Seals (2)
L21	K-L21-SGL K-L21-SGL-A (fluoroelastamer)	Tee-Seals (6), Piston Seal (1), Spring (1)	K-L21-SGL K-L21-SGL-A (fluoroelastamer)	Tee-Seals (6), Piston Seals (2)
L45	K-L45-SGL K-L45-SGL-A (fluoroelastamer)	Tee-Seals (6), Piston Seal (1), Spring (1)	K-L45-SGL K-L45-SGL-A (fluoroelastamer)	Tee-Seals (6), Piston Seals (2)