

	SERIES	DESCRIPTION	BODY NO.	PAGE NO.
CV Check Valves	PARKER STANDARD BODIES AND CAVITIES			
SH Shuttle Valves	C04-2	04 Size, 2 Way	B04-2-*	BC7
	C04-3	04 Size, 3 Way	B04-3-*	BC8
	C08-2	08 Size, 2 Way	B08-2-*	BC9
	C08-3	08 Size, 3 Way	B08-3-*	BC10
	C08-4	08 Size, 4 Way	B08-4-*	BC11
LM Load/Motor Controls	C09-2	09 Size, 2 Way	B09-2-*	BC12
	C10-2	10 Size, 2 Way	B10-2-*	BC13
	C10-2T	10 Size, 2 Way, "T" Body	B10-2T-*	BC14
	C10-3	10 Size, 3 Way	B10-3-*	BC15
FC Flow Controls	C10-3S	10 Size, 3 Way, Short	B10-3S-*	BC16
	C10-4	10 Size, 4 Way	B10-4-*	BC17
	C11-3	11 Size, 3 Way	4082075	BC18
	C12-2	12 Size, 2 Way	B12-2-*	BC19
	C12-3	12 Size, 3 Way	B12-3-*	BC20
PC Pressure Controls	C12-3L	12 Size, 3 Way, Long	B12-3L-*	BC21
	C12-4	12 Size, 4 Way	B12-4-*	BC22
	C12-4L	12 Size, 4 Way, Long	B12-4L-*	BC23
	C16-2	16 Size, 2 Way	B16-2-*	BC24
LE Logic Elements	C16-3	16 Size, 3 Way	B16-3-*	BC25
	C16-3S	16 Size, 3 Way, Short	B16-3S-*	BC26
	C16-4	16 Size, 4 Way	B16-4-*	BC27
	C20-2	20 Size, 2 Way	B20-2-*	BC28
	C20-3S	20 Size, 3 Way, Short	B20-3S-*	BC29
DC Directional Controls	COUNTERBALANCE CAVITIES AND BODIES			
	MHC-010	Single and Dual Counterbalance Bodies	MHC-010-*	BC30
	MHC-022	Single and Dual Counterbalance Bodies	MHC-022-*	BC31
MV Manual Valves	MHC-025	Single and Dual Counterbalance Bodies	MHC-025-*	BC32
	MHC-050	Single and Dual Counterbalance Bodies	MHC-050-*	BC33
SV Solenoid Valves	PILOT PISTON CAVITIES			
	10 Size	10 Size Cavity for Single Check and Pilot Piston		BC34
	16 Size	16 Size Cavity for Single Check and Pilot Piston		BC34
	10 Size	10 Size Cavity for Dual Check and Pilot Piston		BC34
	16 Size	16 Size Cavity for Dual Check and Pilot Piston		BC34
PV Proportional Valves	STANDARD CAVITY PLUGS			
		Cavity Plugs		BC35
CE Coils & Electronics	CARTPAK BODIES			
	BD03-PN	P Port Interrupt, 2-Way, Body Only	BD03-PN-*	BC36
	BD03-PN2	P Port Interrupt, 2-Way, Body Only	BD03-PN2-*	BC37
	BD03-PNR	P Port Interrupt, Reducing Function, Body Only	BD03-PNR-*	BC38
	BD03-PNS	P Port Interrupt, Sequencing Function, Body Only	BD03-PNS-*	BC39
	BD03-PT	P to T, Body Only	BD03-PT-*	BC40
BC Bodies & Cavities	BD03-ABN	A and B Port Interrupt, Body Only	BD03-ABN-*	BC41
	BD03-ABX	A and B Port Crossover, Body Only	BD03-ABX-*	BC42
	BD03-ABT	A and B Ports to Tank, Body Only	BD03-ABT-*	BC43
	BD03-DDX	Ports A and B Drain to Crossover Port, Body Only	BD03-DDX-*	BC44
TD Technical Data	BD03-BDA	B Port Drain to A, Body Only	BD03-BDA-*	BC45
	BD03-ADB	A Port Drain to B, Body Only	BD03-ADB-*	BC46

SERIES	DESCRIPTION	BODY NO.	PAGE NO.
SPECIAL BODIES AND CAVITIES			
CAVOW-2	2 Port	LB1079*	BC47
CAVSW-3	3 Port	LB1081*	BC48
CAVT11A	3 Port or 4 Port Dual	LB1082*	BC49
CAVT21A	4 Port	LB1083*	BC50
2C	2 Port	LB1021*	BC51
2G	2 Port	LB1032*	BC52
2R	2 Port	LB105**	BC53
2U	2 Port	LB102**	BC54
2X	2 Port	LB1051*	BC55
3A	3 Port	LB100**	BC56
3C	3 Port or 4 Port Dual	LB100**	BC57
3J	3 Port	LB1009*	BC58
3K	3 Port		BC59
3M	3 Port or 4 Port Dual	LB100**	BC60
3X	3 Port	LB1055*	BC61
3Z	3 Port	LB103**	BC62
4C	4 Port	LB1056*	BC63
5A	5 Port	LB103**	BC64
53-1	3 Port or 4 Port Dual	LB1031*	BC65
54-1	3 Port	LB10591	BC66
68-1	3 Port or 4 Port Dual	LB102**	BC67
91-1	3 Port	LB1015*	BC68
100-1	5 Port	LB1031*	BC69

CV

Check Valves

SH

Shuttle Valves

LM

Load/Motor Controls

FC

Flow Controls

PC

Pressure Controls

LE

Logic Elements

DC

Directional Controls

MV

Manual Valves

SV

Solenoid Valves

PV

Proportional Valves

CE

Coils & Electronics

BC

Bodies & Cavities

TD

Technical Data

CV

Check Valves

SH

Shuttle Valves

LM

Load/Motor Controls

FC

Flow Controls

PC

Pressure Controls

LE

Logic Elements

DC

Directional Controls

MV

Manual Valves

SV

Solenoid Valves

PV

Proportional Valves

CE

Coils & Electronics

BC

Bodies & Cavities

TD

Technical Data

INTRODUCTION

This Technical Tips section is split into three parts; Standard Line Bodies, Cavities, and Cartpaks. In the standard line bodies section, we highlight the features and options of our standard offering of line bodies. In the cavity section we discuss “common” cavities and form tools. In the Cartpak section, we present the features and options to Parker’s line of D03 style sandwich bodies. The Technical Tips are provided to help you become more familiar with Parker Hannifin’s line of product and assist you in applying our product.

STANDARD LINE BODIES

Parker offers standard line bodies for each valve and cavity size. Below are some of the features of Parker’s standard line bodies.

Yellow Zinc Coating
Steel bodies are coated with yellow zinc dichromate providing protection from salt spray.

Common Cavity
Allows single body to be used for a number of functions.

Various Port Sizes
Each body has a variety of port sizes and types available.

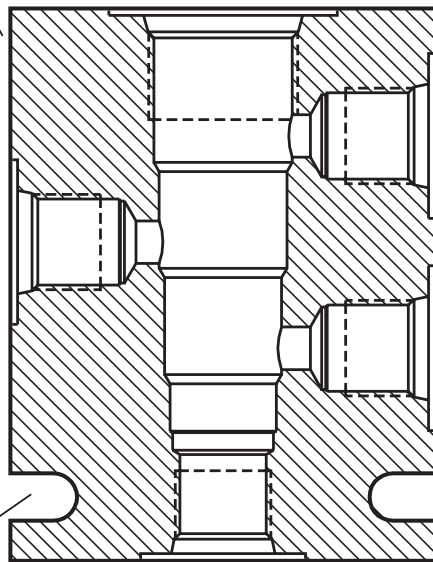

Slotted Mounting Holes
Allows several bodies to be stacked together and held by one set of bolts.

Aluminum and Steel Bodies
Light weight aluminum bodies are available for low pressure applications. Durable steel bodies are available for higher pressures.

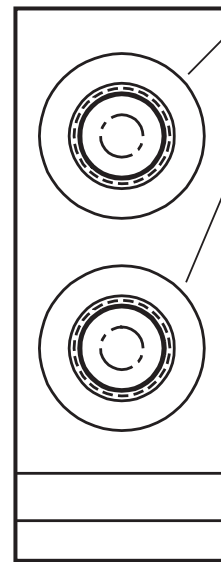

Clear Anodized
Aluminum bodies are thin coated with a clear anodize providing corrosion resistance.

COMMON OPTIONS & FEATURES

Aluminum vs. Steel: Parker offers standard line bodies in both aluminum and steel. Aluminum bodies are most often used for general applications. They are lightweight and less costly than steel bodies. Parker’s aluminum bodies are coated with a clear anodize to provide a corrosion resistant protection. Aluminum bodies should never be used in applications above 210 bar (3000 psi.) Steel bodies are more durable and

heavier than aluminum bodies. They are ideal for applications with elevated pressures or where rugged construction is desired. Steel bodies are suitable for applications up to 350 bar (5000 psi.) Parker’s steel bodies are coated with yellow zinc dichromate providing corrosion resistance. Yellow zinc dichromate even provides the steel body many hours of protection from salt spray.

COMMON OPTIONS & FEATURES (Cont.)

Pressure Drop: The pressure drop through a line body is fairly minimal. Each catalog page shows a pressure drop curve. This should be added to the pressure drop through the cartridge when trying to estimate total pressure drop for a function.

Porting: Parker offers a variety of port sizes and types for each line body. While NPT or pipe ports were once very popular and are still offered, we recommend SAE ports for new applications. SAE ports and fittings provide a more secure connection than pipe ports. BSPP ports are also available.

Port Numbering Change: With this catalog, we have re-numbered the ports on our 3-way line bodies. In the past, three way bodies were numbered with the nose

being port 1, the middle port labeled (3), and the top port labeled (2). Over the years, this has caused some confusion, so we have relabeled the ports sequentially from the bottom. For identification, the current design will be marked with a Parker symbol like the one shown.

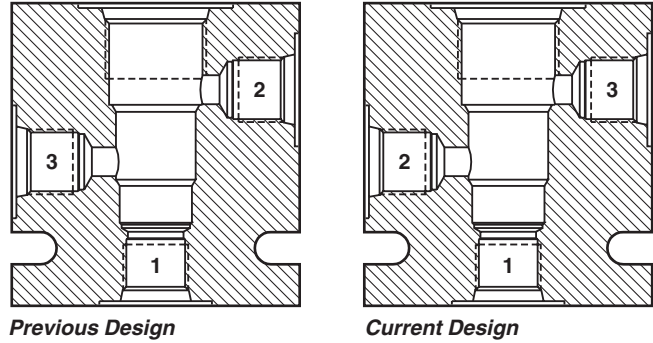

CAVITIES

The hole that the cartridge valve is screwed into is called a cavity. Many cartridge producers manufacture valves that fit a “common” cavity. With a “common” cavity, a valve theoretically could be removed from a cavity and replaced by another manufacturer’s product. One should be careful though to check cross drill ports and thread depths when pursuing this activity. While it is true that many manufacturer’s products fit inside another’s cavity, the cross drills sometimes expose an o-ring to pressure, causing the o-ring to be extruded.

Valve / Cavity Compatibility Chart: Through acquisition, Parker Hannifin has accumulated a number of manufacturers with “common” cavities. To accommodate all of our product lines, we have released a new cavity for our Winner’s Circle product line. The cavities shown in this catalog are considered Winner’s Circle Cavities. The Winner’s Circle valves are downward and upward compatible with the Parker Series of product. On each catalog page, you will find a chart like the one shown on this page. The purpose of this chart is to help identify if a valve from one acquisition can be replaced by the Winner’s Circle valve, or another acquisition. The valves are designated by the columns of the chart and the cavities by the rows. If you have an existing cavity, you find it on the chart and follow across to see which valves you may put in the cavity. For instance, using the chart below, let’s say you have an existing manifold in which you had manufactured a FPS cavity (maybe you were using a SV2A-10). By finding the row labeled FPS and following across, you find that you could use the new Winner’s Circle product, an FPS product, or a CEC product of the same size in this cavity. A Parker or Waterman valve will not fit in this cavity without modifying the cavity. This chart is provided to help you in converting to the Winner’s Circle product line.

		VALVE				
		Winner’s Circle	Parker	Waterman	FPS	CEC
CAVITY	Winner’s Circle	X	X	X	X	X
	Parker	X	X	X		
	Waterman	X	X	X		
	FPS	X			X	X
	CEC	X			X	X

Cavity Tools: On each catalog page, cavity tools are listed for your use in creating special manifolds. More is discussed on manifold construction in the Technical Data section of this catalog. For 3-way and 4-way valves, you will find a roughing and a finishing tool. The rougher is a step drill used to prep the cavity for the finishing tool. The rougher removes the mass of material and is necessary because the finisher is not designed for primary forming. The finisher is a precision tool used to provide the final dimensions of the cavity. No rougher is offered for 2-way cavities because a standard drill bit can be used to remove the mass of material.

- CV Check Valves
- SH Shuttle Valves
- LM Load/Motor Controls
- FC Flow Controls
- PC Pressure Controls
- LE Logic Elements
- DC Directional Controls
- MV Manual Valves
- SV Solenoid Valves
- PV Proportional Valves
- CE Coils & Electronics
- BC Bodies & Cavities
- TD Technical Data

CARTPAK BODIES

Parker Cartpak sandwich mounted bodies are designed to be mounted under a standard ISO 4401-03, NFPA D03, CETOP 3 size valve, and provide a multitude of different functions. The bodies are designed to accept a common 10 size cartridge valve allowing the designer the flexibility to use a single body to provide pressure, directional, flow, or load control. One or more Cartpak bodies may be “sandwiched” underneath a Parker D1 Series directional valve to provide the control functions for all portions of a hydraulic circuit. The ISO standard fatigue rated bodies are available in either aluminum or ductile iron.

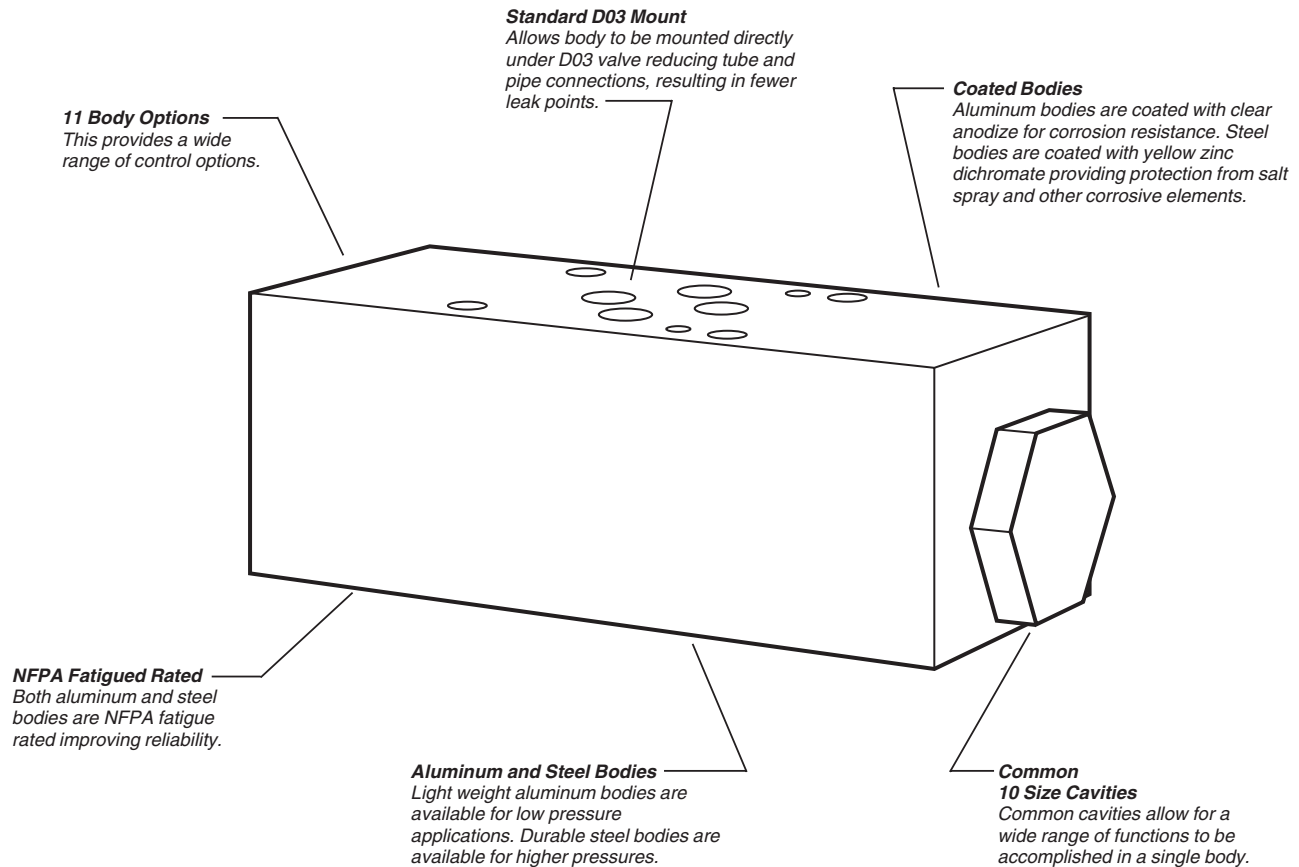

Catalog Pages: Each Cartpak catalog page is laid out in a similar format and is designed to help you select the proper body for your application. In the top left corner of the page there is a brief description and body schematic. The body schematic shows the cartridge cavity and the ports connecting to it. This schematic can be used to understand which valves can be used in the body. For instance, in the

example shown here, flow from the subplate in port P is directed into the nose of the cartridge. The side port of the cartridge is connected to the valve side of port P. Thus, you want to choose cartridges providing the function desired, and use the nose as the inlet. For instance, a FC101 meters flow from its nose port to its side port and would be ideal for the p-port interrupt body shown.

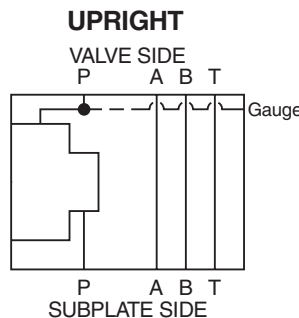

Technical Tips

In addition to the body schematic, we also provide a hydraulic schematic at the bottom of each catalog page. This schematic shows a variety of Parker cartridge part numbers that can be used with this body. This list is not intended to be comprehensive, but it is intended to show the wide variety of options that can be achieved with each body. You will also note, the product listing shows the orientation of the block (upright or inverted), the cavity for the cartridge, and cavity plugs (when necessary.) Once again, many options can be achieved with each body.

O-Ring Plates: Since many of the Cartpak bodies can be “flipped” to achieve extra functions, the faces of the bodies must be flat. Thus, an o-ring plate with o-rings must be used to seal the mounting surface. One plate with o-rings will be provided with any body that can be inverted. *Below are the kit numbers;*

Nitrile Kit - 717939 Fluorocarbon Kit - 717939V

Flipping Cartpaks: As mentioned before, many Cartpak bodies can be flipped to create extra options. The catalog pages show some of the functions that can be achieved by “flipping.” The words “upright” and “inverted” are written on the bodies to help you identify which side you are looking at. To invert the body, while facing the long face of the body (in other words, the sides without any ports or cavities), rotate the valve 180 degrees away from your body in an upward fashion. By doing this, you have essentially switched the P port and T port.

Stacking Cartpaks: Cartpak bodies can be stacked on top of one another to provide a number of functions in a single assembly. When stacking Cartpak bodies though, you want to take some care in the order in which the bodies are stacked. In general, flow controls should be stacked as close to the subplate stack as possible, while pilot operated check valves or counterbalance valves should be stacked as close to the D03 valve as possible.

The D03 line of bodies has a common height of 40mm (1.58 in.). Below is a list of bolt kits available from Parker.

UNC Bolt Kits for use with D1V Directional Control Valves & Manapaks/Cartpaks (D1V*-75 Design, Solenoid Operated)					
	Number of Manapaks/Cartpaks @ 1.58" (40mm) thickness				
	0	1	2	3	4
D1V-75	BK209 1.25"	BK243 2.88"	BK225 4.38"	BK244 6.00"	BK245 7.50"
D1V-75 Plus Tapping Plate	BK176 2.25"	BK56 3.81"	BK212 5.38"	BK107 7.00"	BK106 8.50"

Note: All bolts are SAE grade 8, 10-24 UNC-2A thread, torque to 5.6 N.m. (50 in.-lbs.)

Bodies and Cavities

Gauge Ports: Several of the Cartpak bodies are equipped with a SAE #4 gauge port to assist the user during installation and troubleshooting. We offer hex adapter plugs, should your pressure gauge have a different thread type.

Hex Adapter Plug to convert from SAE #4

1830016	BSPP
1830017	BSPT
1830018	NPTF
1830019	Metric (M12)

Hex Adapter Plug for Converting from #4- SAE to NPTF, M12, BSPT or BSPP Gauge Ports, Where Applicable

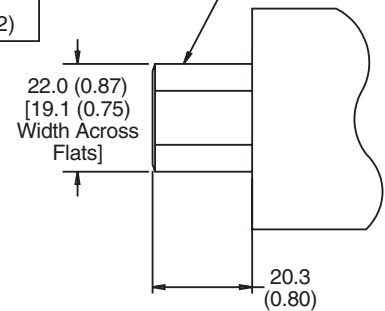

D03 Pad Dimensions: Below is the common dimensions of the standard D03 mount pad. Since these dimensions are common to all Cartpak bodies, we do not identify them on the individual valve pages.

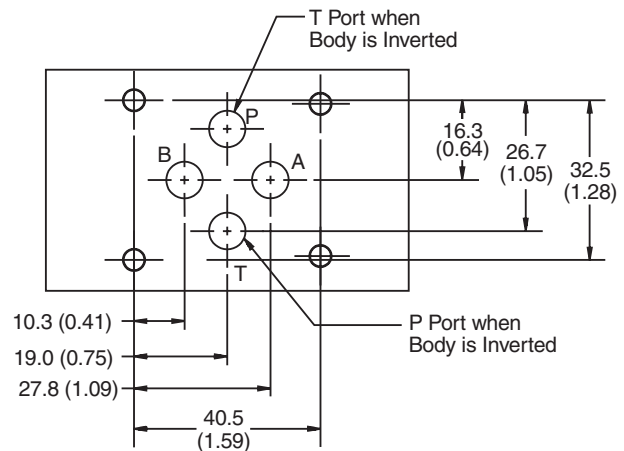

CV

Check Valves

SH

Shuttle Valves

LM

Load/Motor Controls

FC

Flow Controls

PC

Pressure Controls

LE

Logic Elements

DC

Directional Controls

MV

Manual Valves

SV

Solenoid Valves

PV

Proportional Valves

CE

Coils & Electronics

BC

Bodies & Cavities

TD

Technical Data

CV

Check Valves

SH

Shuttle Valves

LM

Load/Motor Controls

FC

Flow Controls

PC

Pressure Controls

LE

Logic Elements

DC

Directional Controls

MV

Manual Valves

SV

Solenoid Valves

PV

Proportional Valves

CE

Coils & Electronics

BC

Bodies & Cavities

TD

Technical Data

PRESSURE DROP CHART

The following charts outline the pressure drop through the Parker Cartpak bodies. The pressure drop is minus the cartridge valve.

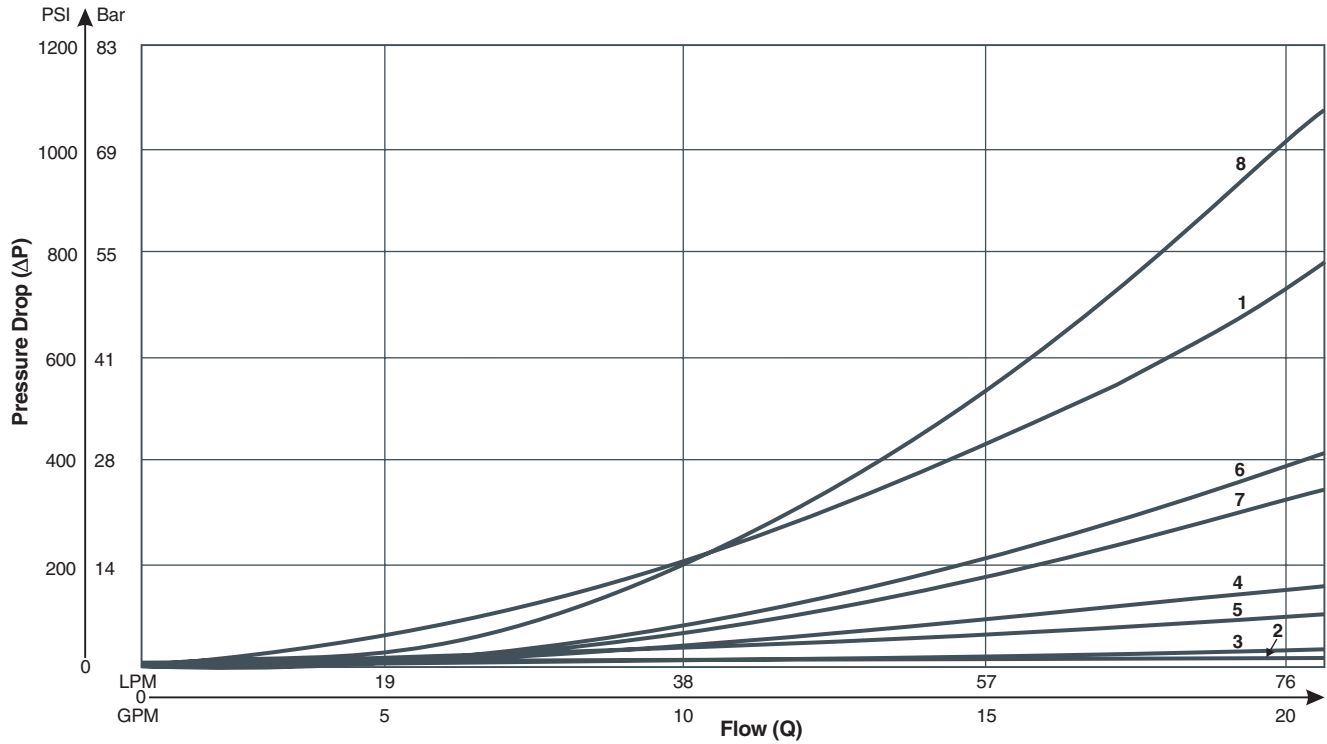

Body	Orientation	P	T	A	B
BD03-PN	Upright	1	2	3	3
	Inverted	2	1	3	3
BD03-PT	Upright	3	3	3	3
	Inverted	3	3	3	3
BD03-ABN	Upright	3	3	4	4
	Inverted	3	3	4	4
BD03-ABT	Upright	3	3	3	3
	Inverted	3	3	3	3
BD03-ABX	Upright	5	5	3	3
BD03-PNR	Upright	6	3	3	3
BD03-PNS	Upright	7	3	3	3
BD03-DDX	Upright	3	3	1	1
BD03-BDA	Upright	6	3	3	3
BD03-ADB	Upright	6	3	3	3
BD03-PN2	Upright	8	3	3	3
	Inverted	3	8	3	3

Notes

Bodies and Cavities

CV
Check
Valves

SH
Shuttle
Valves

LM
Load/Motor
Controls

FC
Flow
Controls

PC
Pressure
Controls

LE
Logic
Elements

DC
Directional
Controls

MV
Manual
Valves

SV
Solenoid
Valves

PV
Proportional
Valves

CE
Coils &
Electronics

BC
Bodies &
Cavities

TD
Technical
Data

BC6



CV

Check Valves

SH

Shuttle Valves

LM

Load/Motor Controls

FC

Flow Controls

PC

Pressure Controls

LE

Logic Elements

DC

Directional Controls

MV

Manual Valves

SV

Solenoid Valves

PV

Proportional Valves

CE

Coils & Electronics

BC

Bodies & Cavities

TD

Technical Data

Valve/Cavity Compatibility

For additional information see Technical Tips on pages BC1-BC6.

CAVITY	VALVE				
	Winner's Circle	Parker	Waterman	FPS	CEC
Winner's Circle	X	X	X		
Parker	X	X	X		
Waterman	X	X	X		
FPS					
CEC					

Performance Curve

Pressure Drop vs. Flow

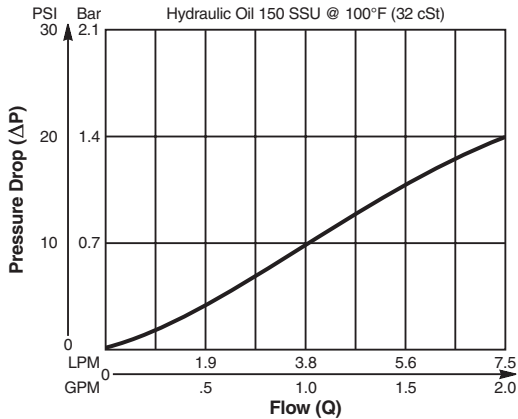

Dimensions

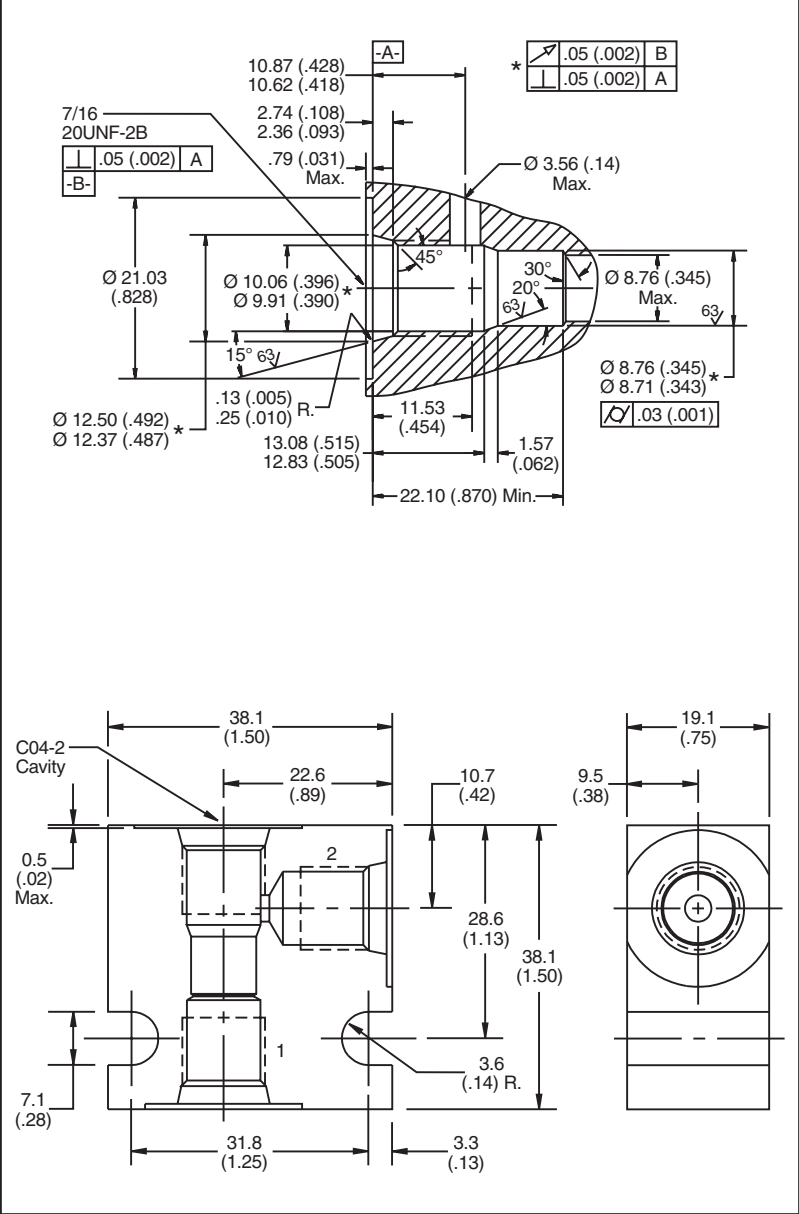

Ordering Information

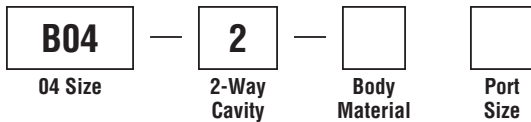

Code	Body Material
Omit	Steel
A	Aluminum

Code	Port Size
4T	SAE - 4

Form Tool: Rougher None
Finisher NFT04-2F
Weight: .07 kg (.15 lbs.)

Valve/Cavity Compatibility

For additional information see Technical Tips on pages BC1-BC6.

		VALVE				
		Winner's Circle	Parker	Waterman	FPS	CEC
CAVITY	Winner's Circle	X	X	X		
	Parker	X	X	X		
	Waterman	X	X	X		
	FPS					
	CEC					

Performance Curve

Pressure Drop vs. Flow

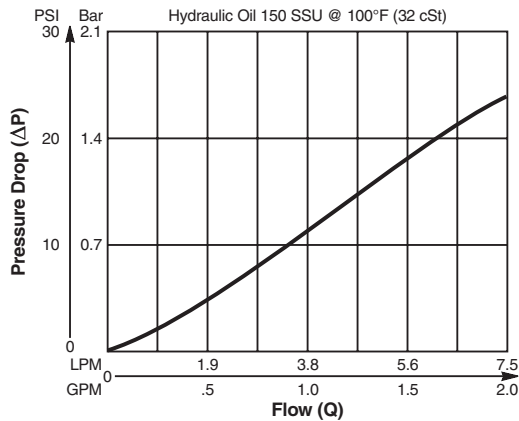

Dimensions Millimeters (Inches)

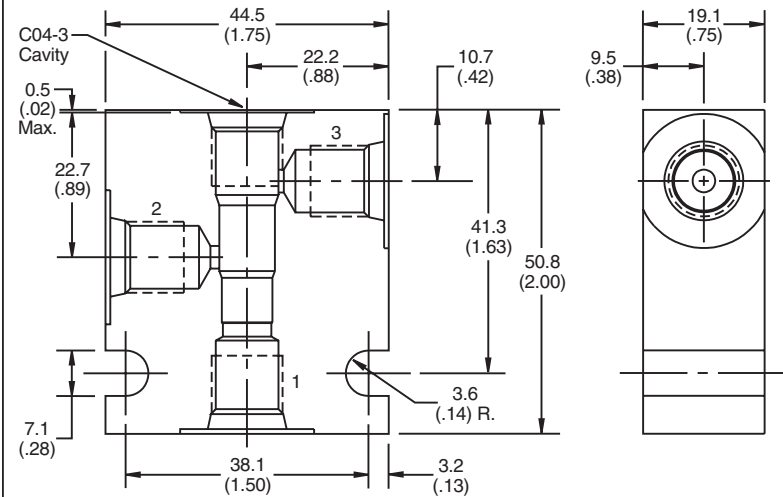
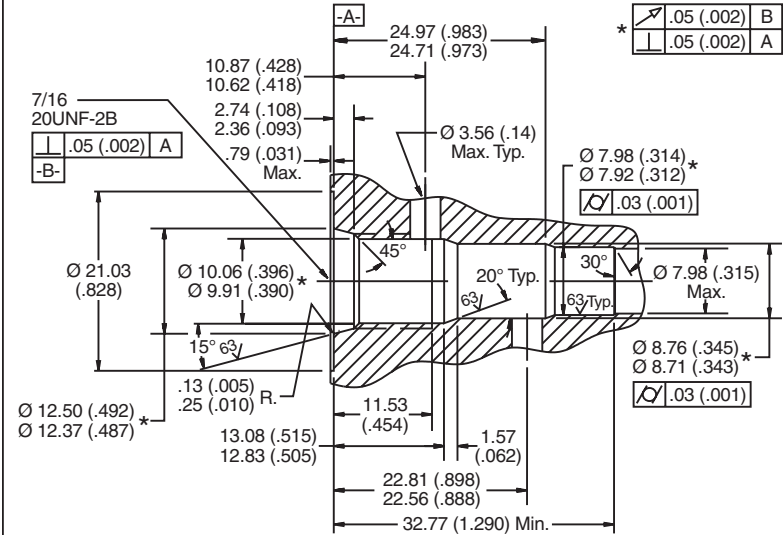

Ordering Information

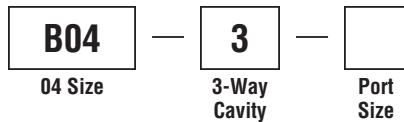

Code	Port Size
A4T	SAE-4

A4T aluminum only.

Form Tool: Rougher NFT04-3R
 Finisher NFT04-3F
Weight: .10 kg (.23 lbs.)

- CV** Check Valves
- SH** Shuttle Valves
- LM** Load/Motor Controls
- FC** Flow Controls
- PC** Pressure Controls
- LE** Logic Elements
- DC** Directional Controls
- MV** Manual Valves
- SV** Solenoid Valves
- PV** Proportional Valves
- CE** Coils & Electronics
- BC** Bodies & Cavities
- TD** Technical Data

- CV** Check Valves
- SH** Shuttle Valves
- LM** Load/Motor Controls
- FC** Flow Controls
- PC** Pressure Controls
- LE** Logic Elements
- DC** Directional Controls
- MV** Manual Valves
- SV** Solenoid Valves
- PV** Proportional Valves
- CE** Coils & Electronics
- BC** Bodies & Cavities
- TD** Technical Data

Valve/Cavity Compatibility

For additional information see Technical Tips on pages BC1-BC6.

CAVITY	VALVE				
	Winner's Circle	Parker	Waterman	FPS	CEC
Winner's Circle	X	X	X	X	X
Parker	X	X	X	X	X
Waterman	X	X	X	X	X
FPS	X	X	X	X	X
CEC	X	X	X	X	X

Performance Curve

Pressure Drop vs. Flow

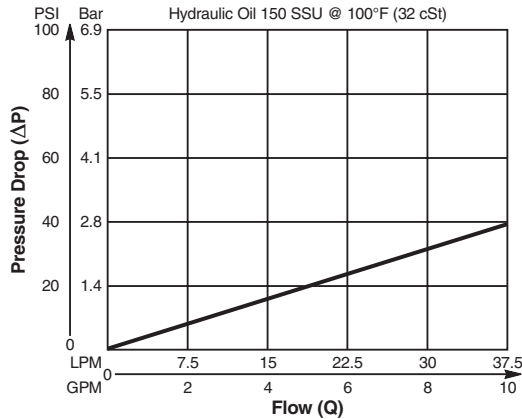

Dimensions

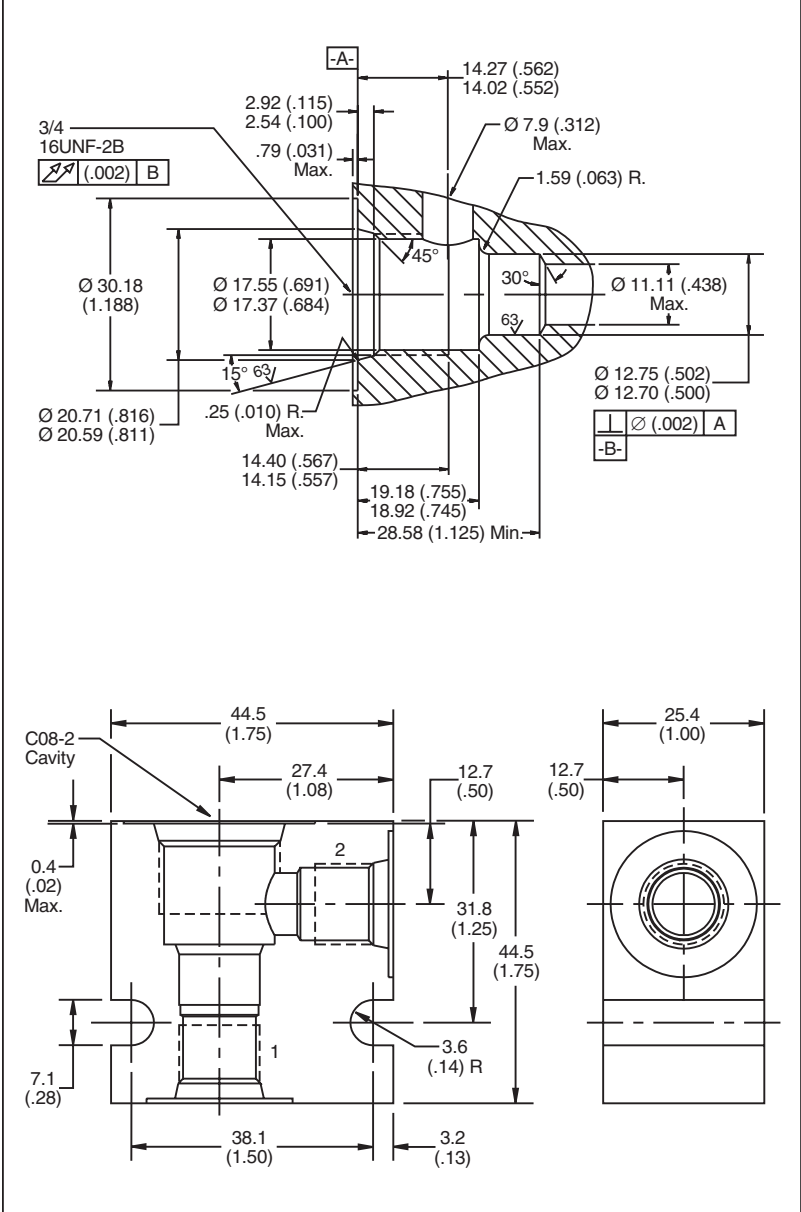

Ordering Information

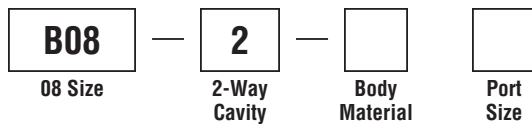

Code	Body Material
Omit	Steel
A	Aluminum

Code	Port Size
4P	1/4" NPTF
6P	3/8" NPTF
4T	SAE - 4
6T	SAE - 6
6B	3/8" BSPG

Form Tool: Rougher None
 Finisher NFT08-2F
Weight: .11 kg (.25 lbs.)

Valve/Cavity Compatibility

For additional information see Technical Tips on pages BC1-BC6.

		VALVE				
		Winner's Circle	Parker	Waterman	FPS	CEC
CAVITY	Winner's Circle	X	X	X		
	Parker	X	X	X		
	Waterman	X	X	X		
	FPS				X	X
	CEC				X	X

Performance Curve

Pressure Drop vs. Flow

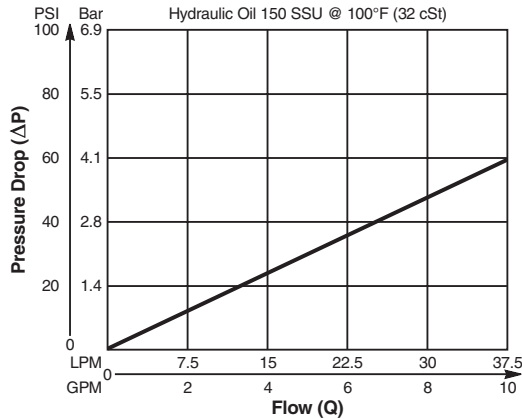

Dimensions Millimeters (Inches)

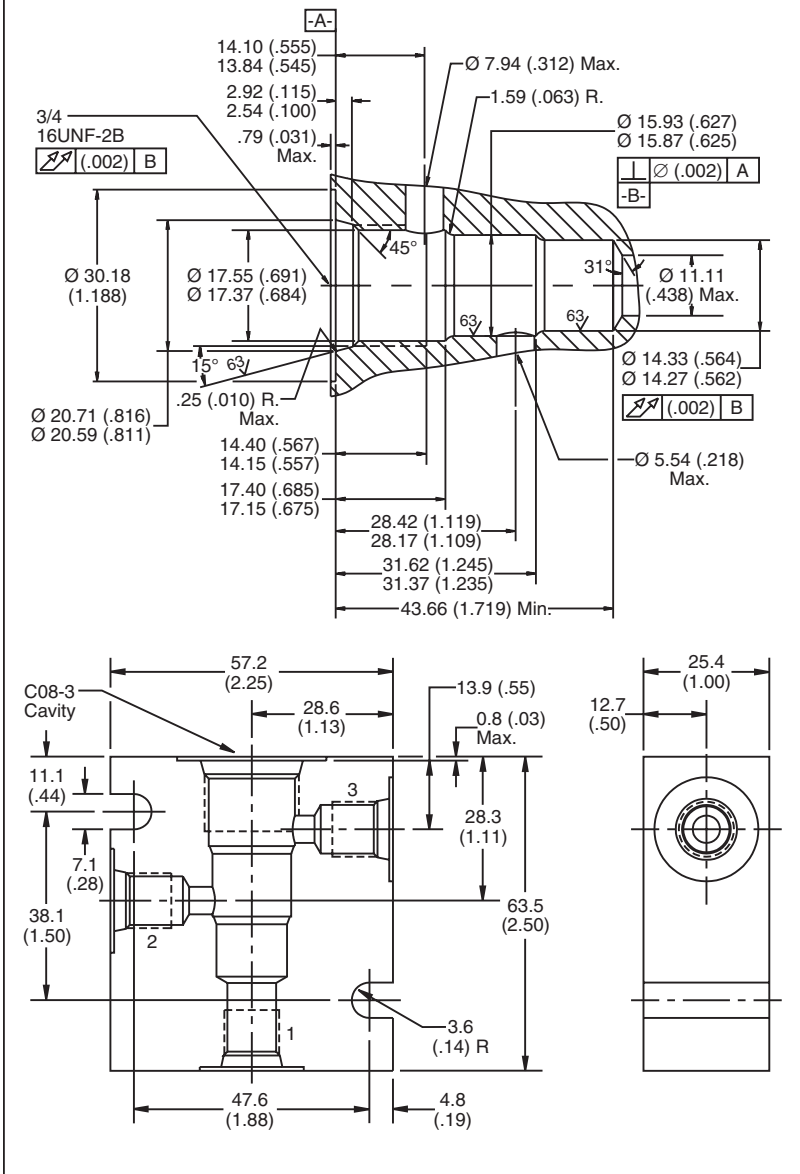

Ordering Information

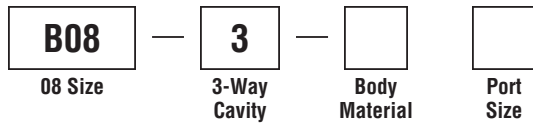

Code	Body Material
Omit	Steel
A	Aluminum

Code	Port Size
4P	1/4" NPTF
4T	SAE - 4
6T	SAE - 6
6B	3/8" BSPG

Form Tool: Rougher NFT08-3R
 Finisher NFT08-3F
Weight: .27 kg (.60 lbs.)

- CV**
Check Valves
- SH**
Shuttle Valves
- LM**
Load/Motor Controls
- FC**
Flow Controls
- PC**
Pressure Controls
- LE**
Logic Elements
- DC**
Directional Controls
- MV**
Manual Valves
- SV**
Solenoid Valves
- PV**
Proportional Valves
- CE**
Coils & Electronics
- BC**
Bodies & Cavities
- TD**
Technical Data

- CV** Check Valves
- SH** Shuttle Valves
- LM** Load/Motor Controls
- FC** Flow Controls
- PC** Pressure Controls
- LE** Logic Elements
- DC** Directional Controls
- MV** Manual Valves
- SV** Solenoid Valves
- PV** Proportional Valves
- CE** Coils & Electronics
- BC** Bodies & Cavities
- TD** Technical Data

Valve/Cavity Compatibility

For additional information see Technical Tips on pages BC1-BC6.

CAVITY	VALVE	Winner's Circle	Parker	Waterman	FPS	CEC
		Winner's Circle	X	X	X	
Parker		X	X	X		
Waterman		X	X	X		
FPS					X	
CEC						

Performance Curve

Pressure Drop vs. Flow

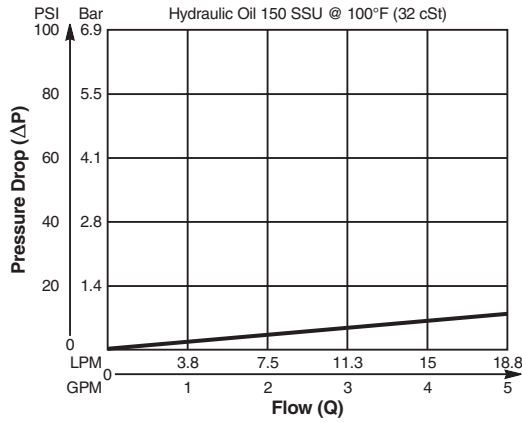

Dimensions

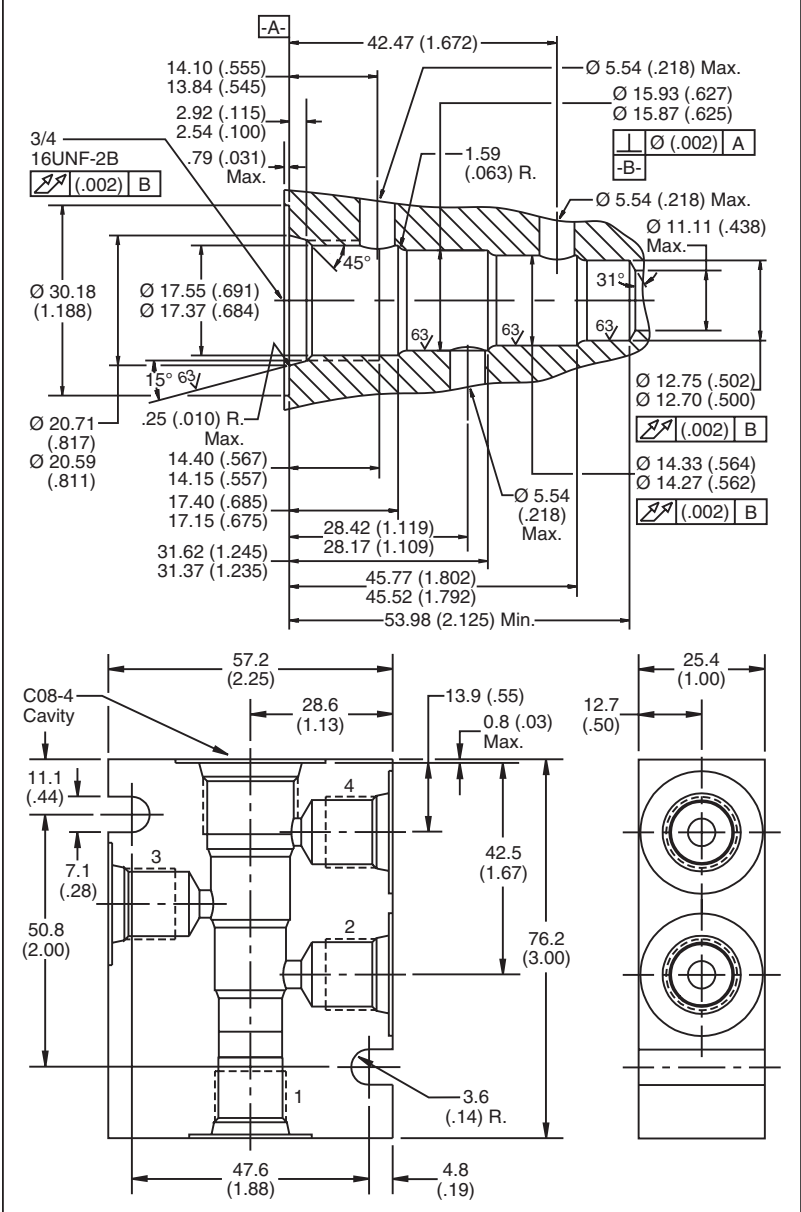

Ordering Information

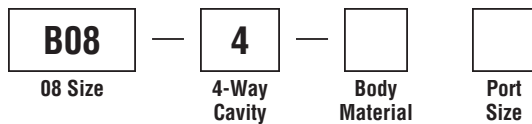

Code	Body Material
Omit	Steel
A	Aluminum

Code	Port Size
4T	SAE - 4
6T	SAE - 6
6B	3/8" BSPG

Form Tool: Rougher NFT08-4R
 Finisher NFT08-4F
Weight: .45 kg (1.0 lbs.)

Valve/Cavity Compatibility

For additional information see Technical Tips on pages BC1-BC6.

		VALVE				
		Winner's Circle	Parker	Waterman	FPS	CEC
CAVITY	Winner's Circle					
	Parker		X	X		
	Waterman		X	X		
	FPS					
	CEC					

Performance Curve

Pressure Drop vs. Flow

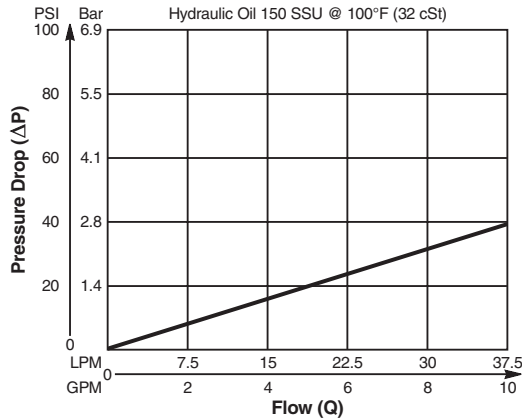

Dimensions Millimeters (Inches)

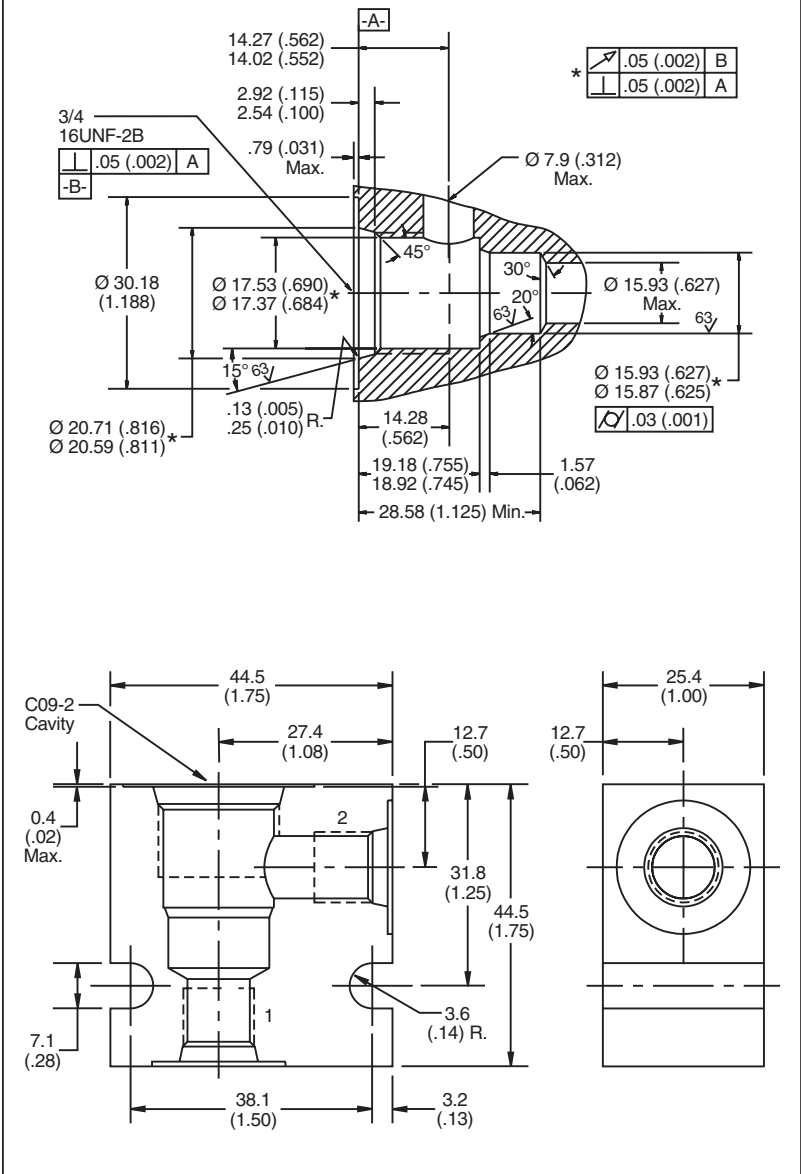

Ordering Information

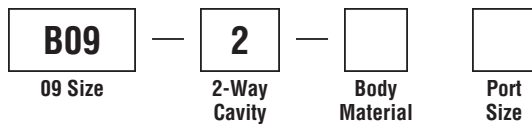

Code	Body Material
Omit	Steel
A	Aluminum

Code	Port Size
6T	SAE - 6
6B†	3/8" BSPG

† Steel body only.

Form Tool: Rougher None
 Finisher FT09-2
Weight: 11 kg (.25 lbs.)

- CV** Check Valves
- SH** Shuttle Valves
- LM** Load/Motor Controls
- FC** Flow Controls
- PC** Pressure Controls
- LE** Logic Elements
- DC** Directional Controls
- MV** Manual Valves
- SV** Solenoid Valves
- PV** Proportional Valves
- CE** Coils & Electronics
- BC** Bodies & Cavities
- TD** Technical Data

Technical Information

- CV Check Valves
- SH Shuttle Valves
- LM Load/Motor Controls
- FC Flow Controls
- PC Pressure Controls
- LE Logic Elements
- DC Directional Controls
- MV Manual Valves
- SV Solenoid Valves
- PV Proportional Valves
- CE Coils & Electronics
- BC Bodies & Cavities
- TD Technical Data

Valve/Cavity Compatibility

For additional information see Technical Tips on pages BC1-BC6.

CAVITY	VALVE				
	Winner's Circle	Parker	Waterman	FPS	CEC
Winner's Circle	X	X	X	X	X
Parker	X	X	X		
Waterman	X	X	X		
FPS	X			X	X
CEC	X			X	X

Performance Curve

Pressure Drop vs. Flow

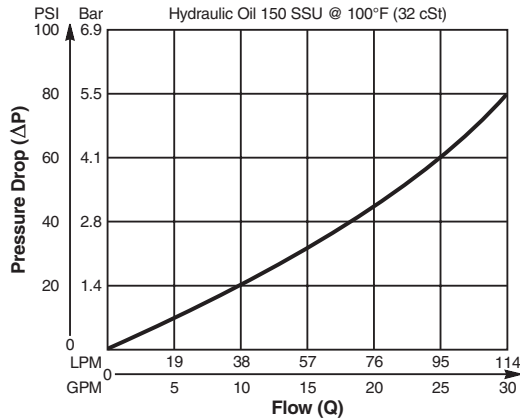

Dimensions Millimeters (Inches)

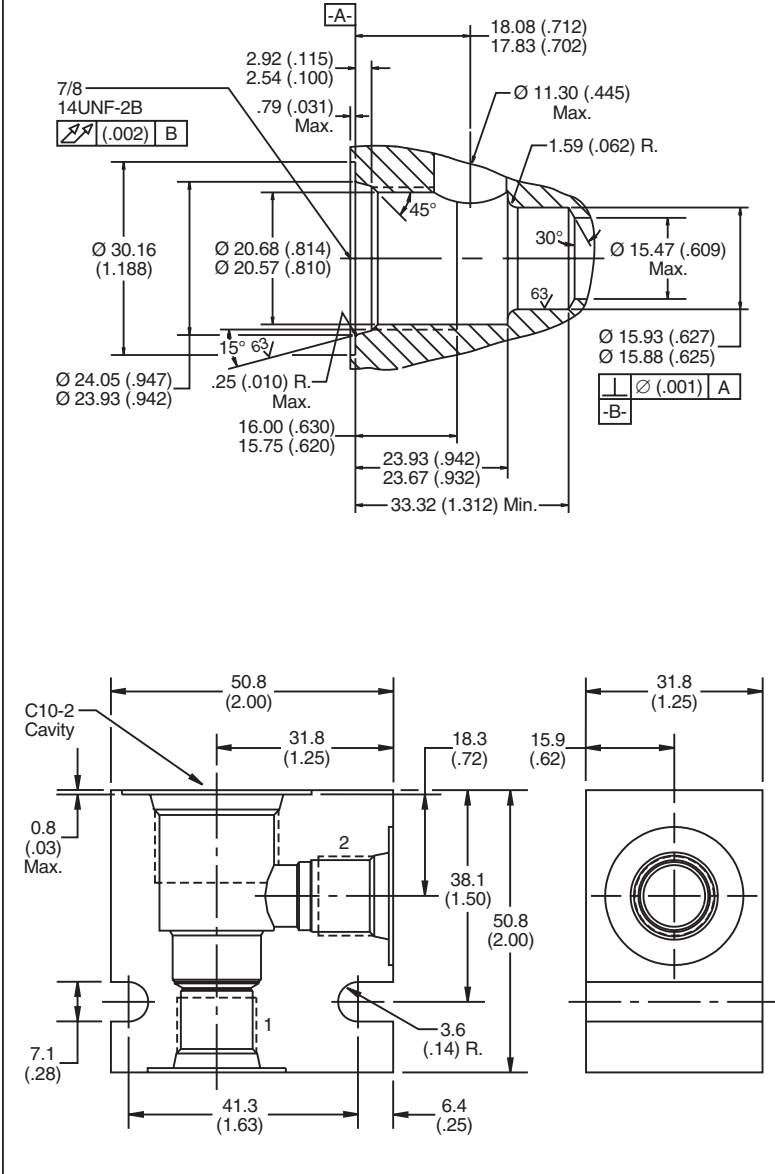

Ordering Information

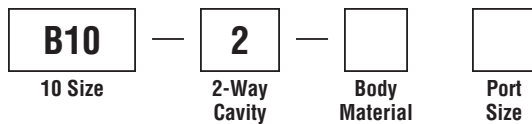

Code	Body Material	Code	Port Size
Omit	Steel	4P	1/4" NPTF
A	Aluminum	6P	3/8" NPTF
		8P	1/2" NPTF
		6T	SAE - 6
		8T	SAE - 8
		6BT	3/8" BSPG

† Steel body only.

Form Tool: Rougher None
Finisher NFT10-2F
Weight: .45 kg (1.0 lbs.)

Valve/Cavity Compatibility

For additional information see Technical Tips on pages BC1-BC6.

		VALVE				
		Winner's Circle	Parker	Waterman	FPS	CEC
CAVITY	Winner's Circle	X	X	X	X	X
	Parker	X	X	X		
	Waterman	X	X	X		
	FPS	X			X	X
	CEC	X			X	X

Performance Curve

Pressure Drop vs. Flow

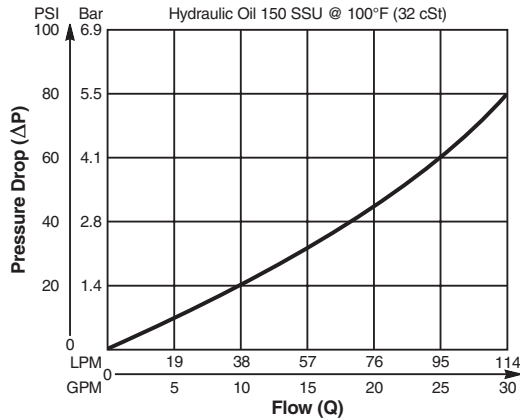

Dimensions Millimeters (Inches)

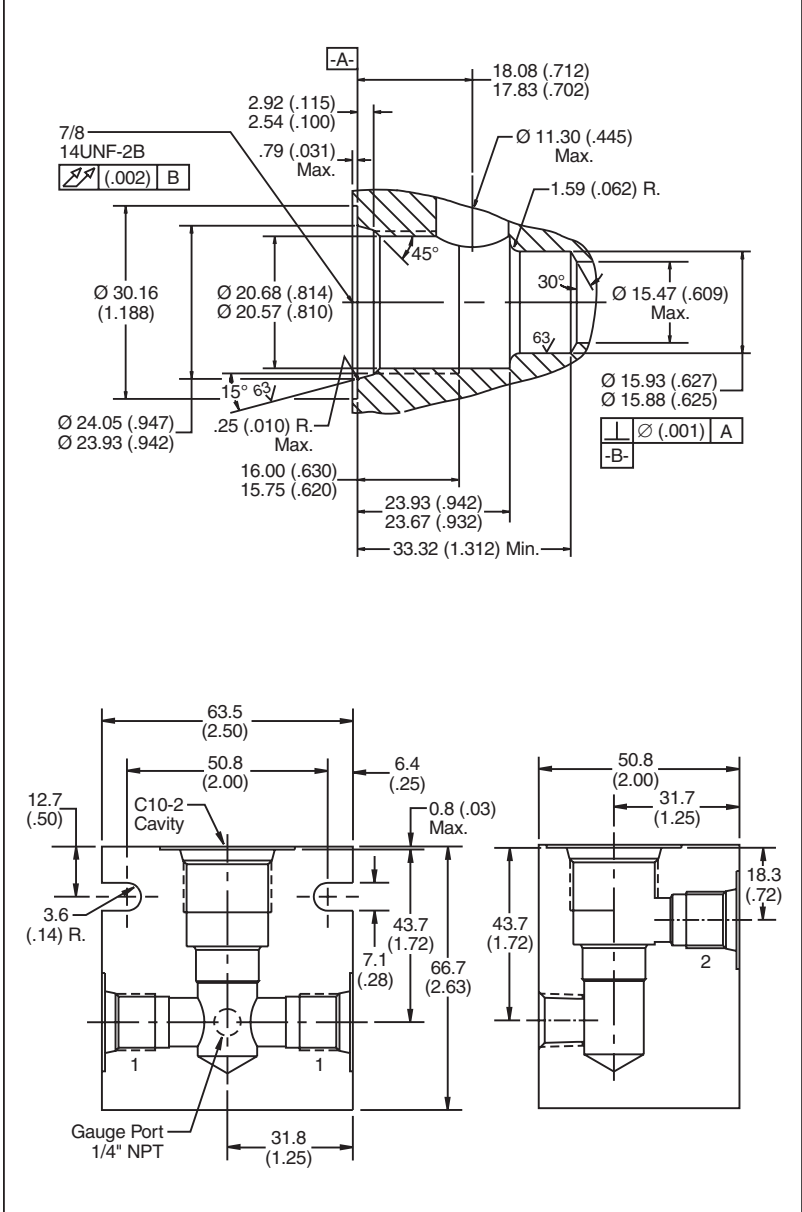

Ordering Information

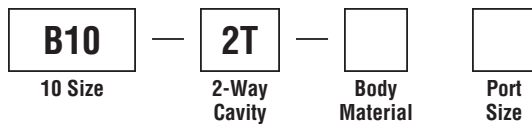

Code	Body Material
Omit	Steel

Code	Port Size
T6T	SAE - 6
T8T	SAE - 8

Form Tool: Rougher None
 Finisher NFT10-2F
Weight: 1.4 kg (3.0 lbs.)

- CV** Check Valves
- SH** Shuttle Valves
- LM** Load/Motor Controls
- FC** Flow Controls
- PC** Pressure Controls
- LE** Logic Elements
- DC** Directional Controls
- MV** Manual Valves
- SV** Solenoid Valves
- PV** Proportional Valves
- CE** Coils & Electronics
- BC** Bodies & Cavities
- TD** Technical Data

Technical Information

- CV Check Valves
- SH Shuttle Valves
- LM Load/Motor Controls
- FC Flow Controls
- PC Pressure Controls
- LE Logic Elements
- DC Directional Controls
- MV Manual Valves
- SV Solenoid Valves
- PV Proportional Valves
- CE Coils & Electronics
- BC Bodies & Cavities
- TD Technical Data

Valve/Cavity Compatibility

For additional information see Technical Tips on pages BC1-BC6.

CAVITY	VALVE				
	Winner's Circle	Parker	Waterman	FPS	CEC
Winner's Circle	X	X	X	X	X
Parker	X	X	X	X	X
Waterman	X	X	X	X	X
FPS	X	X	X	X	X
CEC	X	X	X	X	X

Performance Curve

Pressure Drop vs. Flow

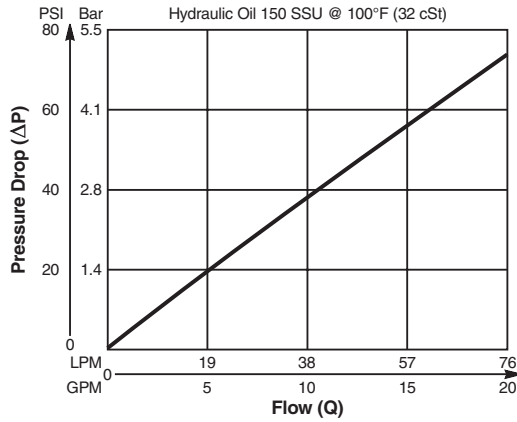

Dimensions Millimeters (Inches)

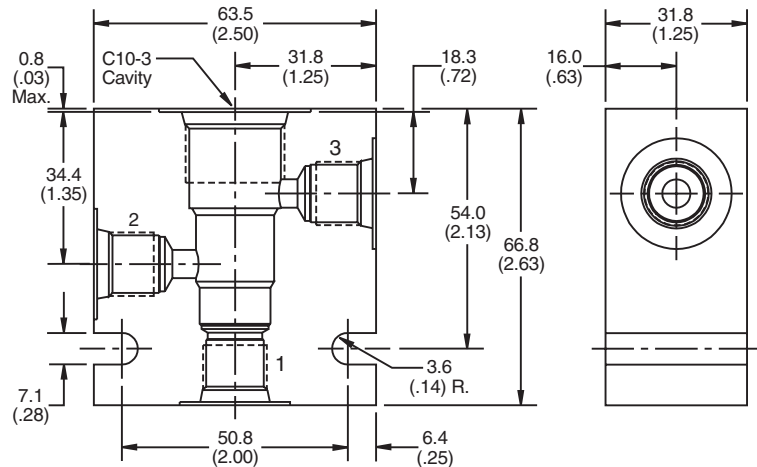
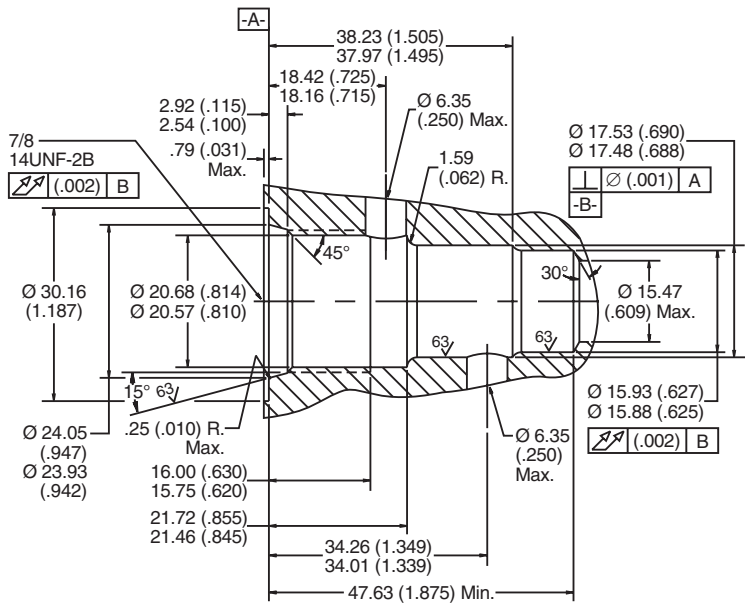

Ordering Information

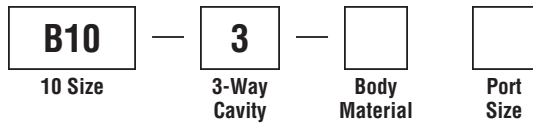

Code	Body Material	Code	Port Size
Omit	Steel	4P	1/4" NPTF
A	Aluminum	6P	3/8" NPTF
		8P	1/2" NPTF
		6T	SAE - 6
		8T	SAE - 8
		6B†	3/8" BSPG
		8B	1/2" BSPG

† Steel body only.

Form Tool: Rougher NFT10-3R
Finisher NFT10-3F
Weight: .77 kg (1.7 lbs.)

Valve/Cavity Compatibility

For additional information see Technical Tips on pages BC1-BC6.

		VALVE				
		Winner's Circle	Parker	Waterman	FPS	CEC
CAVITY	Winner's Circle	X			X	X
	Parker					
	Waterman					
	FPS	X			X	X
	CEC	X			X	X

Performance Curve

Pressure Drop vs. Flow

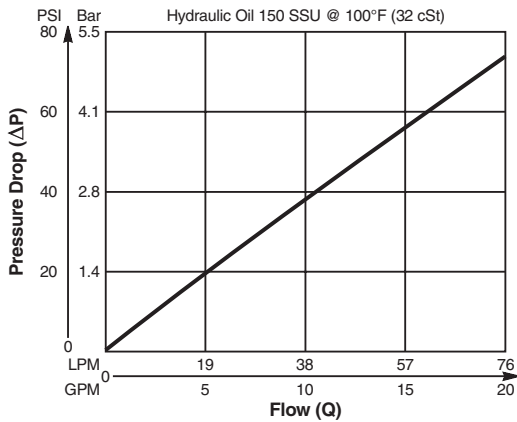

Dimensions Millimeters (Inches)

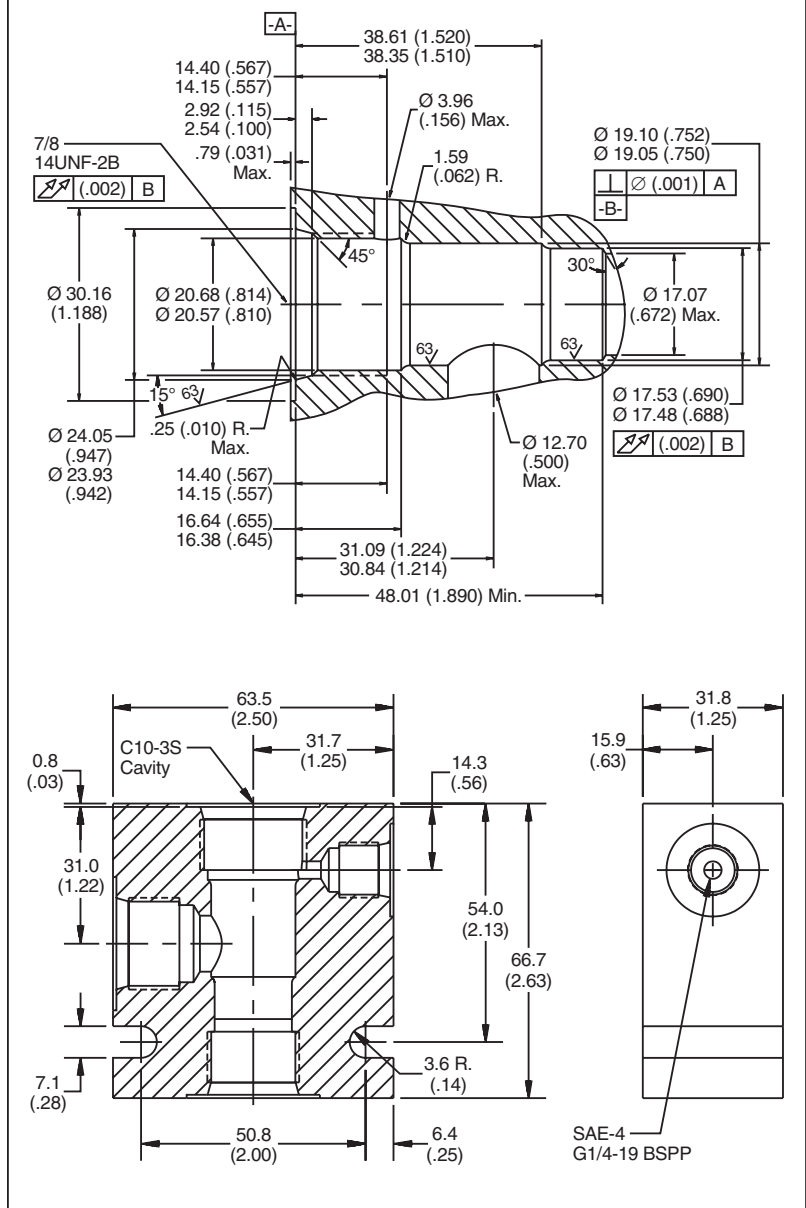

Ordering Information

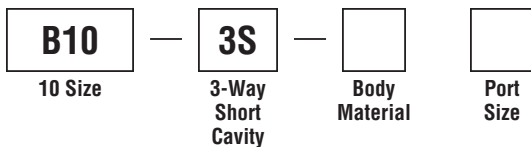

Code	Body Material
Omit	Steel
A	Aluminum

Code	Port Size
6T	SAE - 6
8T	SAE - 8
6B	3/8" BSPG
8B	1/2" BSPG

Form Tool: Rougher NFT10S-3R
 Finisher NFT10S-3F
Weight: .77 kg (1.7 lbs.)

- CV** Check Valves
- SH** Shuttle Valves
- LM** Load/Motor Controls
- FC** Flow Controls
- PC** Pressure Controls
- LE** Logic Elements
- DC** Directional Controls
- MV** Manual Valves
- SV** Solenoid Valves
- PV** Proportional Valves
- CE** Coils & Electronics
- BC** Bodies & Cavities
- TD** Technical Data

Technical Information

- CV Check Valves
- SH Shuttle Valves
- LM Load/Motor Controls
- FC Flow Controls
- PC Pressure Controls
- LE Logic Elements
- DC Directional Controls
- MV Manual Valves
- SV Solenoid Valves
- PV Proportional Valves
- CE Coils & Electronics
- BC Bodies & Cavities
- TD Technical Data

Valve/Cavity Compatibility

For additional information see Technical Tips on pages BC1-BC6.

CAVITY	VALVE				
	Winner's Circle	Parker	Waterman	FPS	CEC
Winner's Circle	X	X	X	X	X
Parker	X	X	X	X	X
Waterman	X	X	X	X	X
FPS	X	X	X	X	X
CEC	X	X	X	X	X

Performance Curve

Pressure Drop vs. Flow

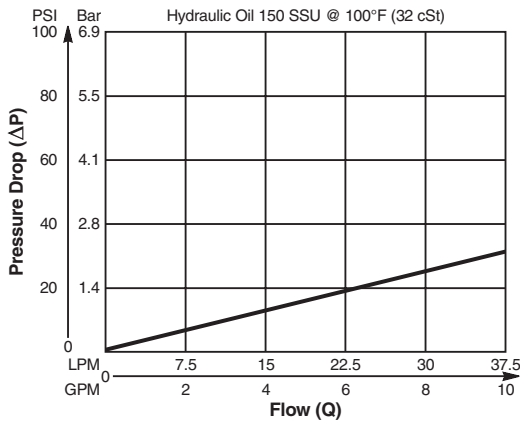

NOTE:

When machining for use with DF102P, Ports 1 and 4 must be connected in the manifold/block.

Dimensions Millimeters (Inches)

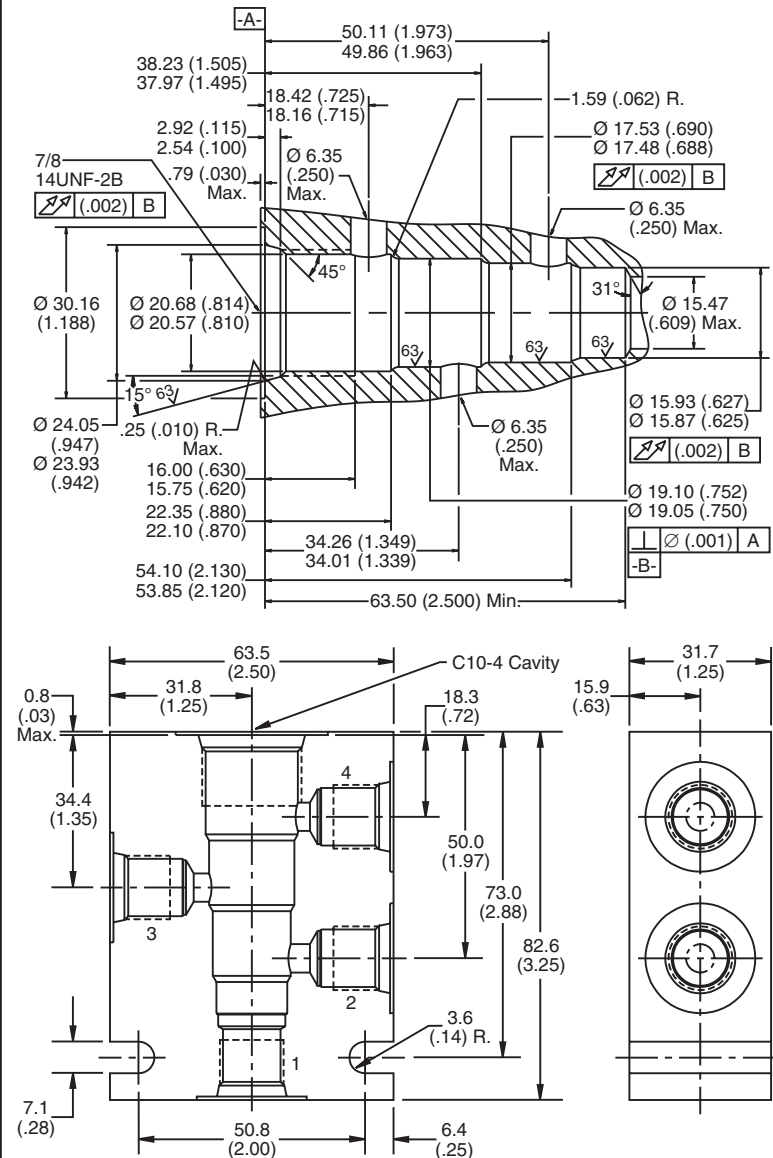

Ordering Information

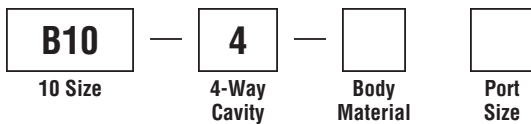

Code	Body Material
Omit	Steel
A	Aluminum

Code	Port Size
6P	3/8" NPTF
6T	SAE - 6
8T	SAE - 8
6BT	3/8" BSPG

† Steel body only.

Form Tool: Rougher NFT10-4R
Finisher NFT10-4F
Weight: .90 kg (2.0 lbs.)

Valve/Cavity Compatibility

For additional information see Technical Tips on pages BC1-BC6.

		VALVE				
		Winner's Circle	Parker	Waterman	FPS	CEC
CAVITY	Winner's Circle					
	Parker		X	X	X	
	Waterman		X	X	X	
	FPS		X	X	X	
	CEC					

Performance Curve

Pressure Drop vs. Flow

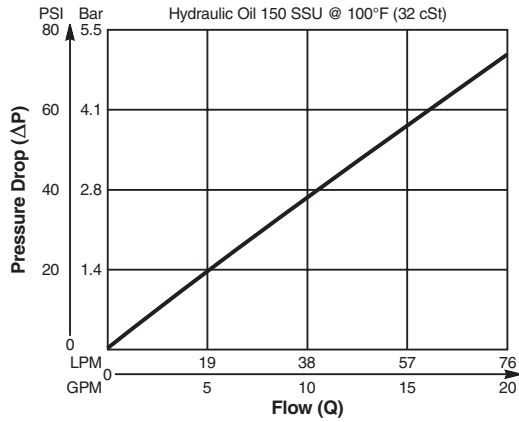

Dimensions Millimeters (Inches)

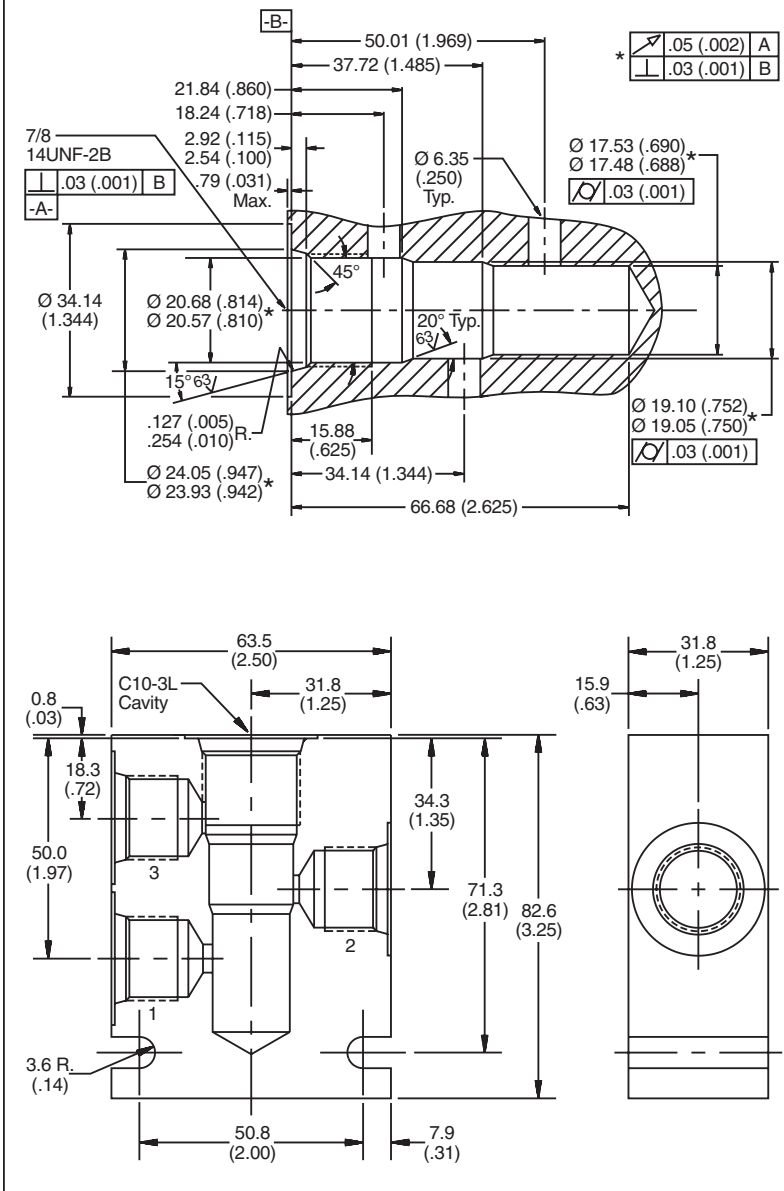

Ordering Information

Part Number = 4082075

- CV** Check Valves
- SH** Shuttle Valves
- LM** Load/Motor Controls
- FC** Flow Controls
- PC** Pressure Controls
- LE** Logic Elements
- DC** Directional Controls
- MV** Manual Valves
- SV** Solenoid Valves
- PV** Proportional Valves
- CE** Coils & Electronics
- BC** Bodies & Cavities
- TD** Technical Data



Technical Information

- CV Check Valves
- SH Shuttle Valves
- LM Load/Motor Controls
- FC Flow Controls
- PC Pressure Controls
- LE Logic Elements
- DC Directional Controls
- MV Manual Valves
- SV Solenoid Valves
- PV Proportional Valves
- CE Coils & Electronics
- BC Bodies & Cavities
- TD Technical Data

Valve/Cavity Compatibility

For additional information see Technical Tips on pages BC1-BC6.

CAVITY	VALVE				
	Winner's Circle	Parker	Waterman	FPS	CEC
Winner's Circle	X	X	X		
Parker	X	X	X		
Waterman	X	X	X		
FPS					
CEC					X

Performance Curve

Pressure Drop vs. Flow

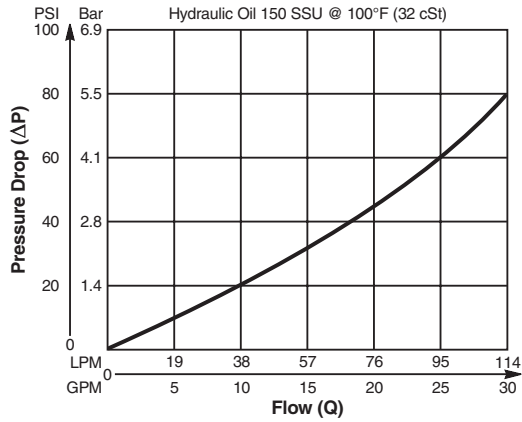

Dimensions Millimeters (Inches)

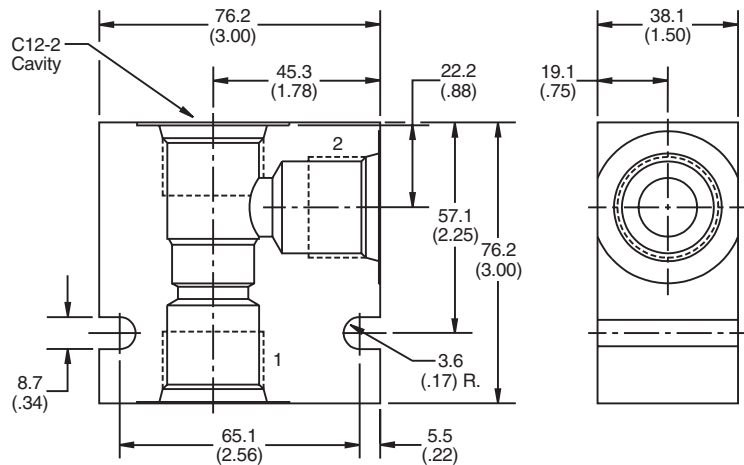
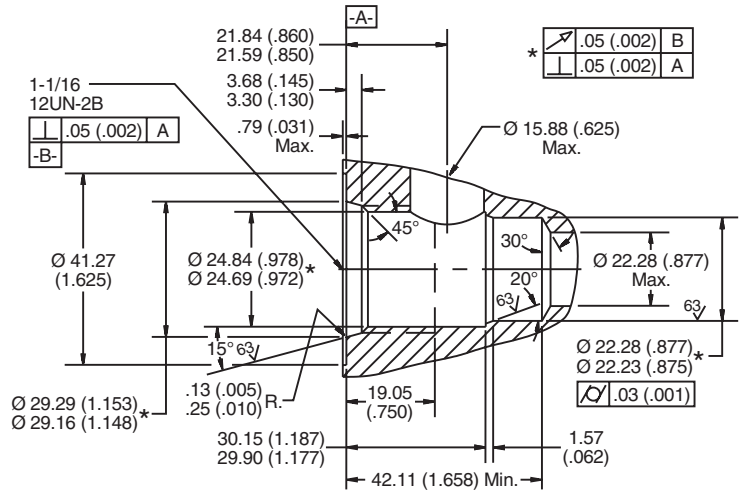

Ordering Information

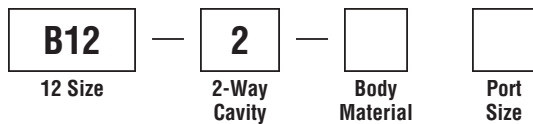

Code	Body Material
Omit	Steel
A	Aluminum

Code	Port Size
12P	3/4" NPTF
8T	SAE - 8
12T	SAE - 12

Form Tool: Rougher None
Finisher NFT12-2F
Weight: .45 kg (1.0 lbs.)

Valve/Cavity Compatibility

For additional information see Technical Tips on pages BC1-BC6.

		VALVE				
		Winner's Circle	Parker	Waterman	FPS	CEC
CAVITY	Winner's Circle	X	X	X		
	Parker	X	X	X		
	Waterman	X	X	X		
	FPS					
	CEC					X

Performance Curve

Pressure Drop vs. Flow

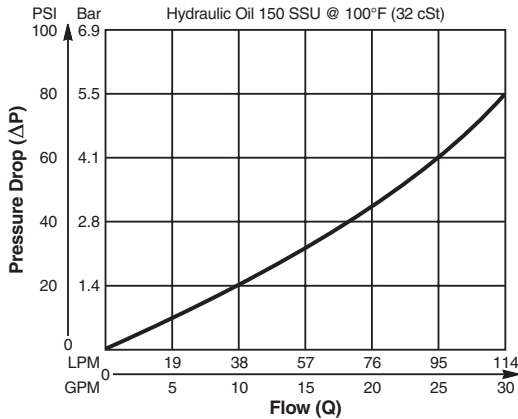

Dimensions Millimeters (Inches)

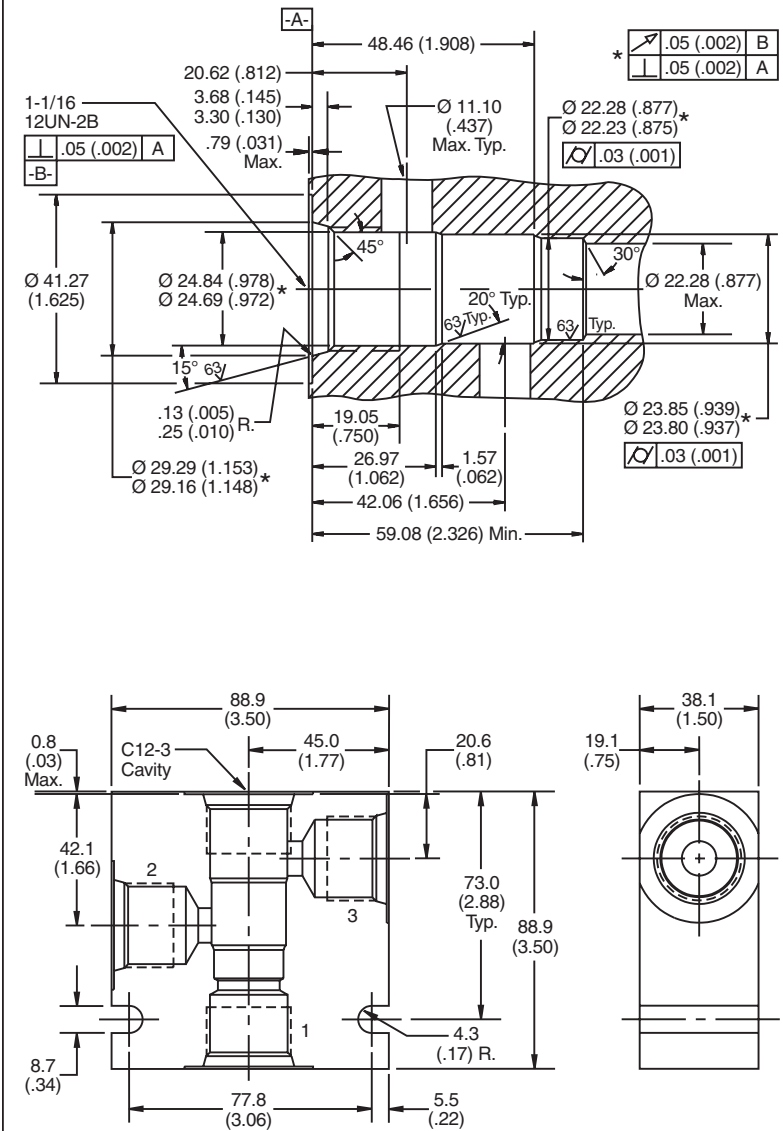

Ordering Information

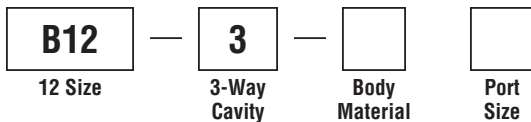

Code	Body Material
Omit	Steel
A	Aluminum

Code	Port Size
8T	SAE - 8
12T	SAE - 12
8B†	1/2" BSPG

† Steel body only.

Form Tool: Rougher NFT12-3R
 Finisher NFT12-3F
Weight: 2.0 kg (4.5 lbs.)

- CV** Check Valves
- SH** Shuttle Valves
- LM** Load/Motor Controls
- FC** Flow Controls
- PC** Pressure Controls
- LE** Logic Elements
- DC** Directional Controls
- MV** Manual Valves
- SV** Solenoid Valves
- PV** Proportional Valves
- CE** Coils & Electronics
- BC** Bodies & Cavities
- TD** Technical Data

- CV** Check Valves
- SH** Shuttle Valves
- LM** Load/Motor Controls
- FC** Flow Controls
- PC** Pressure Controls
- LE** Logic Elements
- DC** Directional Controls
- MV** Manual Valves
- SV** Solenoid Valves
- PV** Proportional Valves
- CE** Coils & Electronics
- BC** Bodies & Cavities
- TD** Technical Data

Valve/Cavity Compatibility

For additional information see Technical Tips on pages BC1-BC6.

Performance Curve
Pressure Drop vs. Flow

Dimensions Millimeters (Inches)

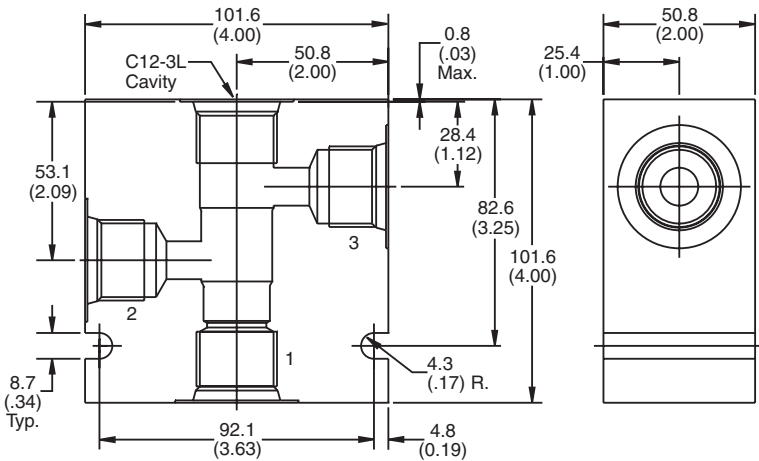
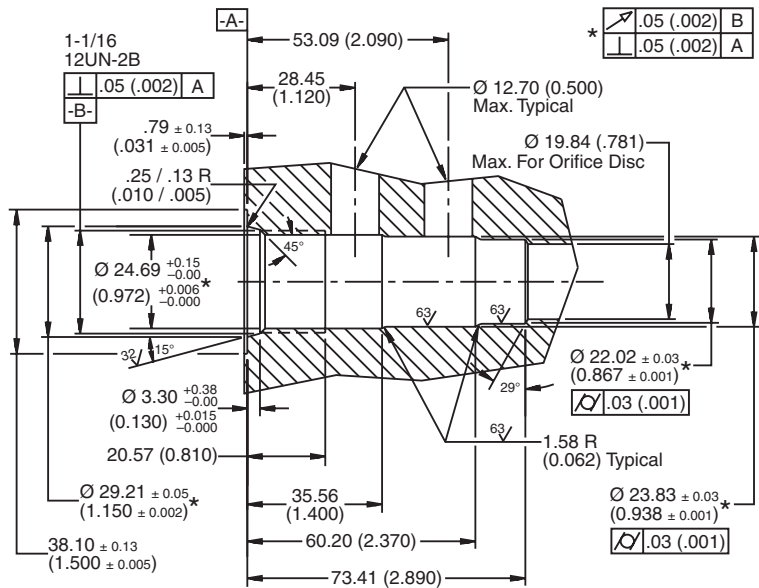

Ordering Information

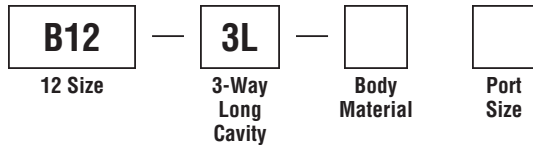

Code	Body Material
Omit	Steel
A	Aluminum

Code	Port Size
12T	SAE - 12

Form Tool: Rougher NFT12L-3R
Finisher NFT12L-3F

Weight:

Valve/Cavity Compatibility

For additional information see Technical Tips on pages BC1-BC6.

		VALVE				
		Winner's Circle	Parker	Waterman	FPS	CEC
CAVITY	Winner's Circle	X	X	X		
	Parker	X	X	X		
	Waterman	X	X	X		
	FPS					
	CEC					X

Performance Curve

Pressure Drop vs. Flow

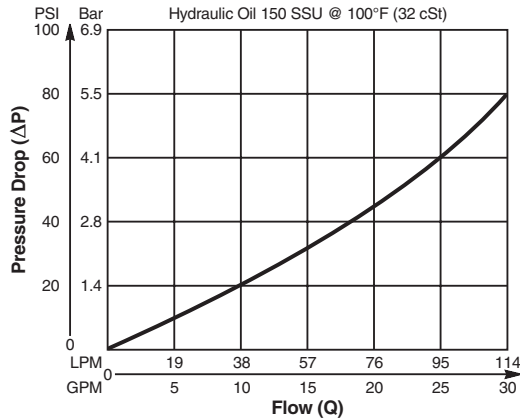

Dimensions Millimeters (Inches)

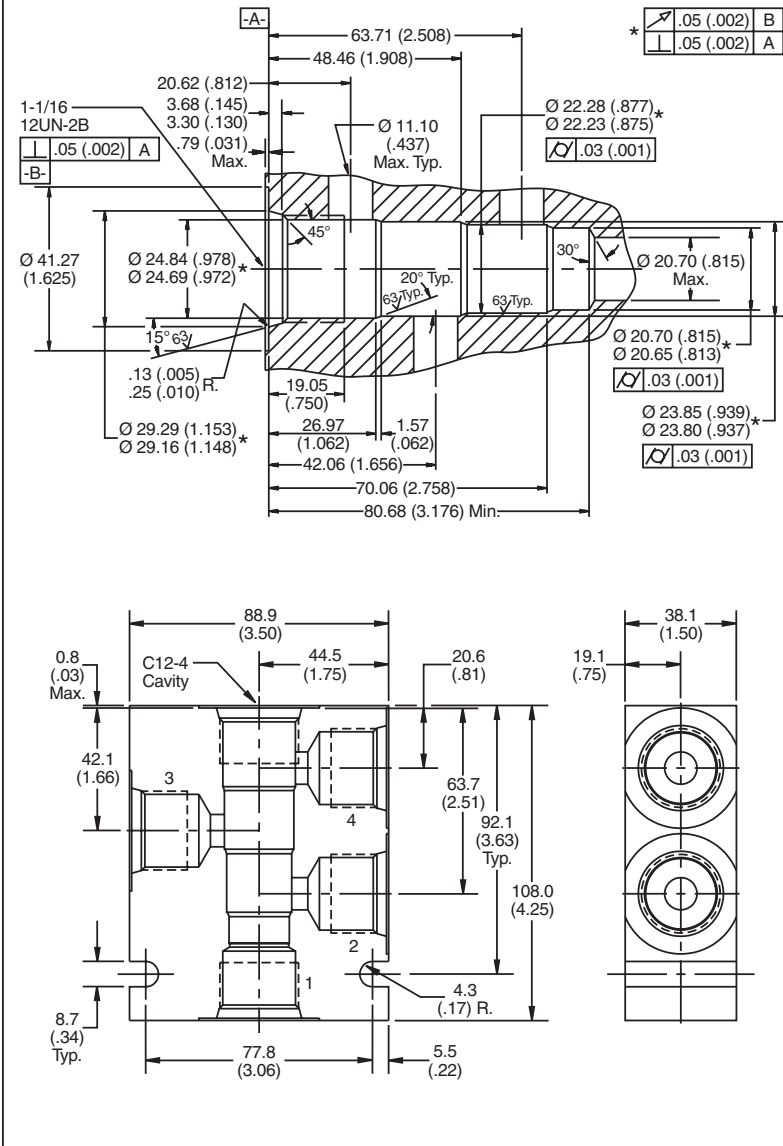

Ordering Information

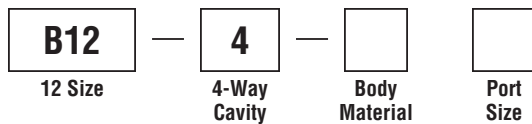

Code	Body Material
Omit	Steel
A	Aluminum

Code	Port Size
12T	SAE - 12

Form Tool: Rougher NFT12-4R
 Finisher NFT12-4F
Weight: 3.3 kg (7.3 lbs.)

- CV** Check Valves
- SH** Shuttle Valves
- LM** Load/Motor Controls
- FC** Flow Controls
- PC** Pressure Controls
- LE** Logic Elements
- DC** Directional Controls
- MV** Manual Valves
- SV** Solenoid Valves
- PV** Proportional Valves
- CE** Coils & Electronics
- BC** Bodies & Cavities
- TD** Technical Data

Valve/Cavity Compatibility

For additional information see Technical
 Tips on pages BC1-BC6.

Performance Curve
 Pressure Drop vs. Flow

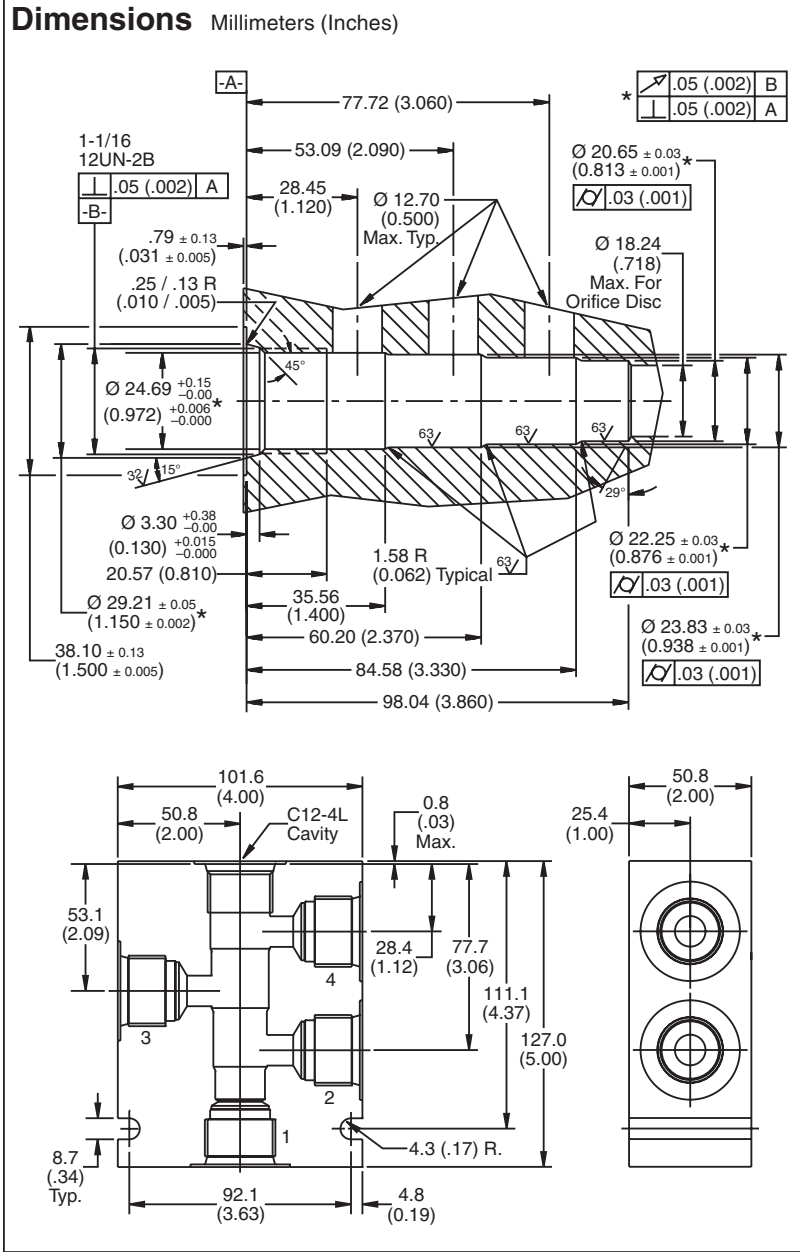

- CV** Check Valves
- SH** Shuttle Valves
- LM** Load/Motor Controls
- FC** Flow Controls
- PC** Pressure Controls
- LE** Logic Elements
- DC** Directional Controls
- MV** Manual Valves
- SV** Solenoid Valves
- PV** Proportional Valves
- CE** Coils & Electronics
- BC** Bodies & Cavities
- TD** Technical Data

Ordering Information

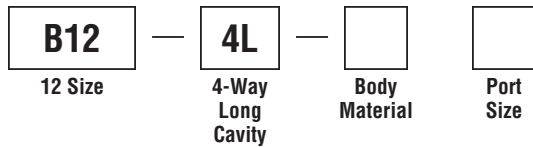

Code	Body Material
Omit	Steel
A	Aluminum

Code	Port Size
12T	SAE - 12

Form Tool: Rougher NFT12L-4R
 Finisher NFT12L-4F

Weight:

Valve/Cavity Compatibility

For additional information see Technical Tips on pages BC1-BC6.

		VALVE				
		Winner's Circle	Parker	Waterman	FPS	CEC
CAVITY	Winner's Circle	X	X	X	X	X
	Parker	X	X	X		
	Waterman	X	X	X		
	FPS	X			X	X
	CEC	X			X	X

Performance Curve

Pressure Drop vs. Flow

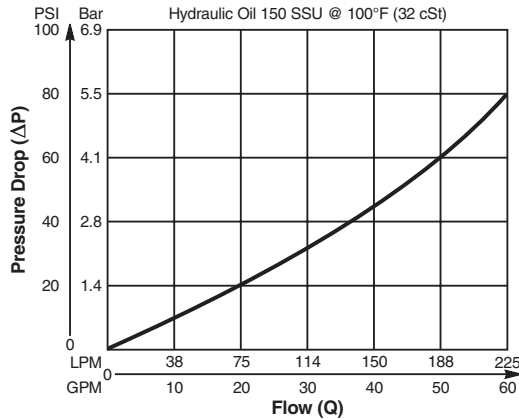

Dimensions Millimeters (Inches)

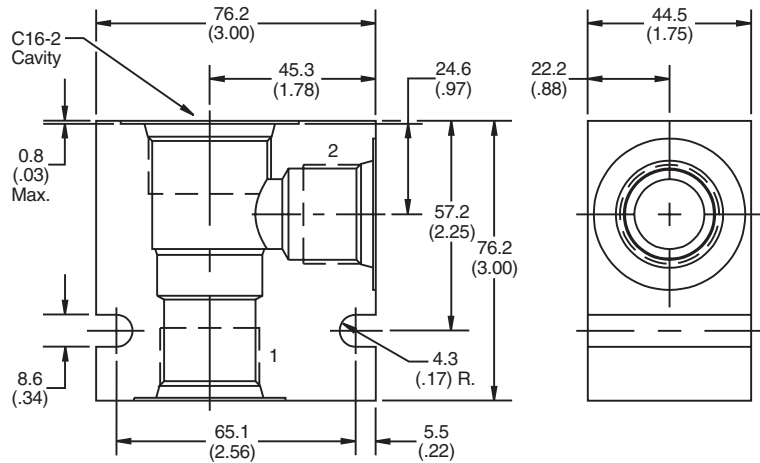
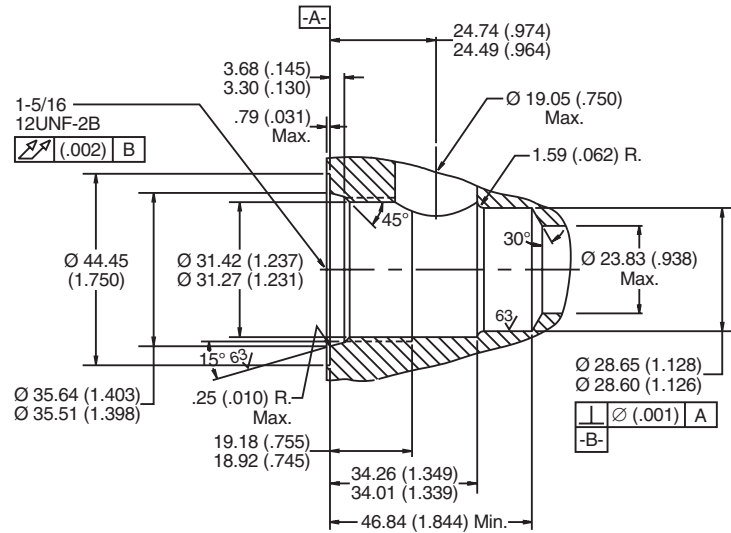

Ordering Information

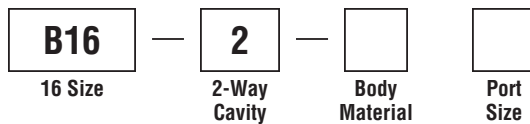

Code	Body Material
Omit	Steel
A	Aluminum

Code	Port Size
12P	3/4" NPTF
16P	1" NPTF
8T	SAE - 8
12T	SAE - 12
16T	SAE - 16
12B†	3/4" BSPG
16B	1" BSPG

† Steel body only.

Form Tool: Rougher None
 Finisher NFT16-2F
Weight: 1.5 kg (3.4 lbs.)

- CV** Check Valves
- SH** Shuttle Valves
- LM** Load/Motor Controls
- FC** Flow Controls
- PC** Pressure Controls
- LE** Logic Elements
- DC** Directional Controls
- MV** Manual Valves
- SV** Solenoid Valves
- PV** Proportional Valves
- CE** Coils & Electronics
- BC** Bodies & Cavities
- TD** Technical Data

Technical Information

- CV** Check Valves
- SH** Shuttle Valves
- LM** Load/Motor Controls
- FC** Flow Controls
- PC** Pressure Controls
- LE** Logic Elements
- DC** Directional Controls
- MV** Manual Valves
- SV** Solenoid Valves
- PV** Proportional Valves
- CE** Coils & Electronics
- BC** Bodies & Cavities
- TD** Technical Data

Valve/Cavity Compatibility

For additional information see Technical Tips on pages BC1-BC6.

CAVITY	VALVE				
	Winner's Circle	Parker	Waterman	FPS	CEC
Winner's Circle	X	X	X	X	X
Parker	X	X	X		
Waterman	X	X	X		
FPS	X			X	X
CEC	X			X	X

Performance Curve

Pressure Drop vs. Flow

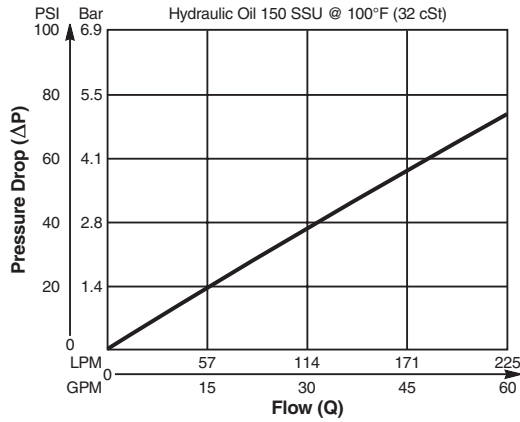

Dimensions Millimeters (Inches)

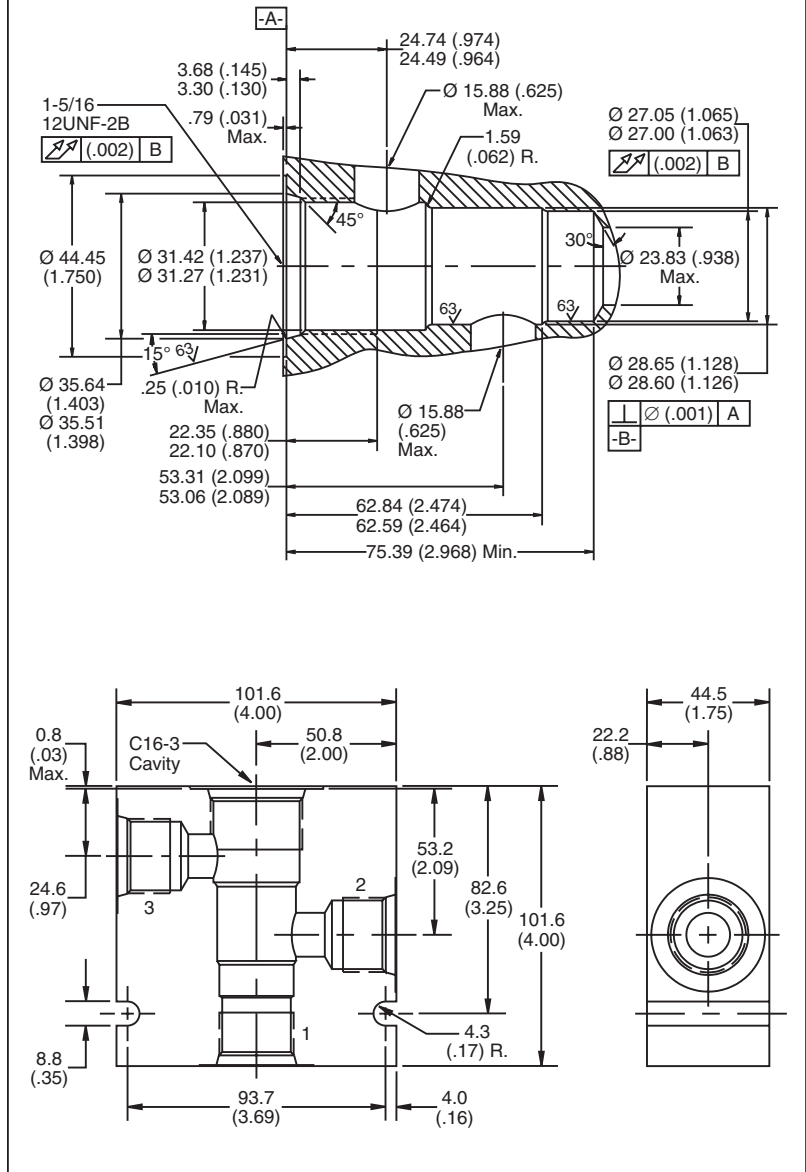

Ordering Information

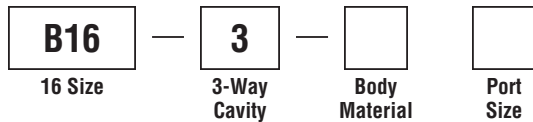

Code	Body Material	Code	Port Size
Omit	Steel	12T	SAE - 12
A	Aluminum	16T	SAE - 16

Form Tool: Rougher NFT16-3R
Finisher NFT16-3F
Weight: 3.0 kg (6.5 lbs.)

Valve/Cavity Compatibility

For additional information see Technical Tips on pages BC1-BC6.

		VALVE				
		Winner's Circle	Parker	Waterman	FPS	CEC
CAVITY	Winner's Circle	X	X	X	X	X
	Parker	X	X	X	X	X
	Waterman	X	X	X	X	X
	FPS	X	X	X	X	X
	CEC	X	X	X	X	X

Performance Curve

Pressure Drop vs. Flow

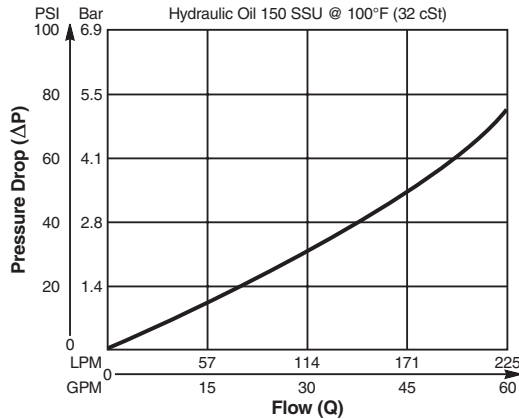

Dimensions Millimeters (Inches)

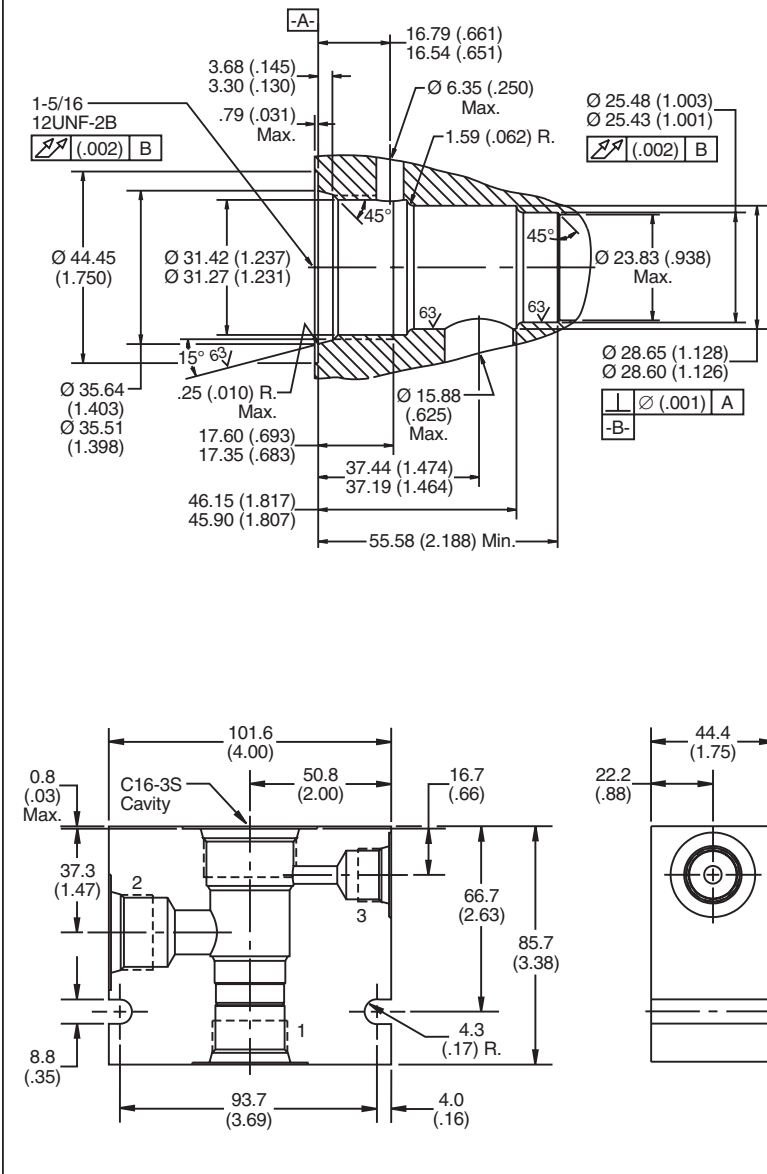

Ordering Information

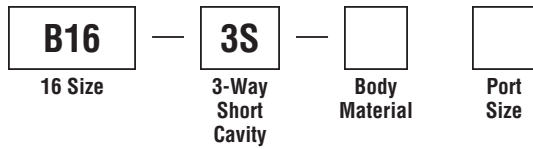

Code	Body Material	Code	Port Size
Omit	Steel	16T	SAE - 16
A	Aluminum	16B	1" BSPG

Form Tool: Rougher NFT16S-3R
 Finisher NFT16S-3F
Weight: 2.4 kg (5.4 lbs.)

- CV** Check Valves
- SH** Shuttle Valves
- LM** Load/Motor Controls
- FC** Flow Controls
- PC** Pressure Controls
- LE** Logic Elements
- DC** Directional Controls
- MV** Manual Valves
- SV** Solenoid Valves
- PV** Proportional Valves
- CE** Coils & Electronics
- BC** Bodies & Cavities
- TD** Technical Data

Technical Information

- CV Check Valves
- SH Shuttle Valves
- LM Load/Motor Controls
- FC Flow Controls
- PC Pressure Controls
- LE Logic Elements
- DC Directional Controls
- MV Manual Valves
- SV Solenoid Valves
- PV Proportional Valves
- CE Coils & Electronics
- BC Bodies & Cavities
- TD Technical Data

Valve/Cavity Compatibility

For additional information see Technical Tips on pages BC1-BC6.

CAVITY	VALVE				
	Winner's Circle	Parker	Waterman	FPS	CEC
Winner's Circle	X	X	X	X	X
Parker	X	X	X		
Waterman	X	X	X		
FPS	X			X	X
CEC	X			X	X

Performance Curve
Pressure Drop vs. Flow

Dimensions Millimeters (Inches)

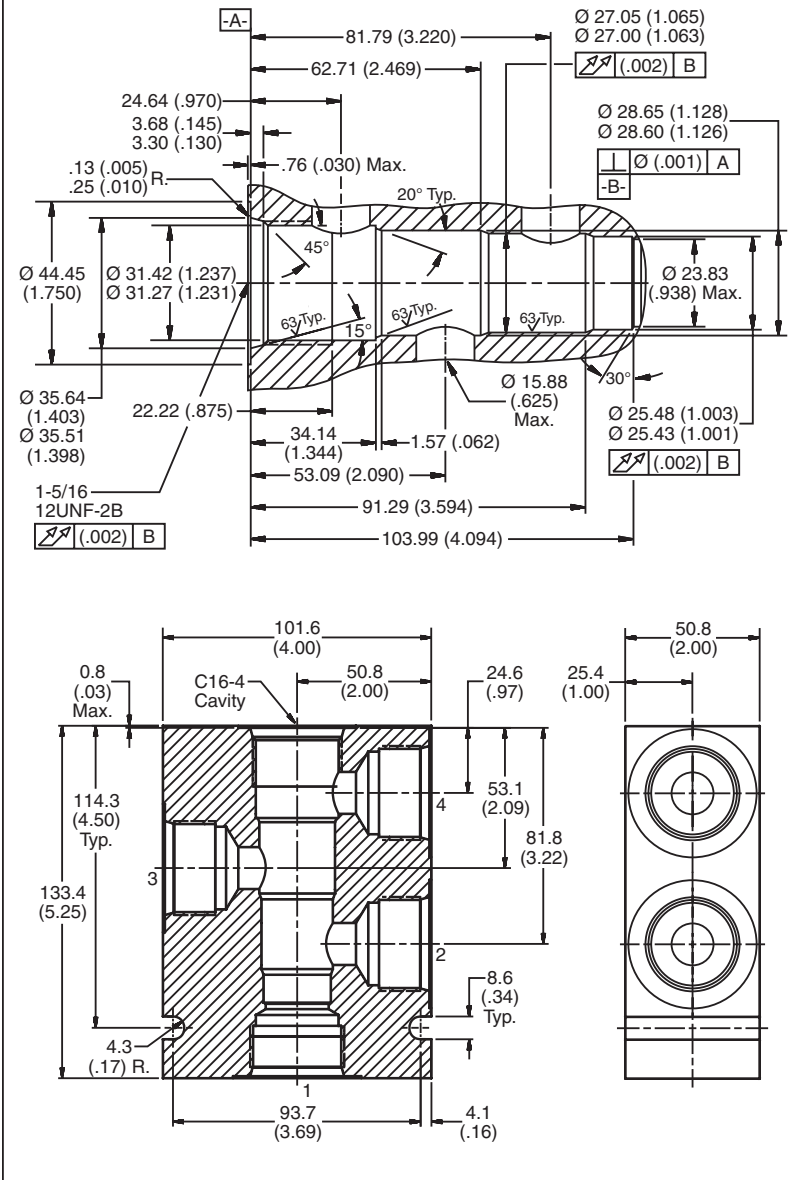

Ordering Information

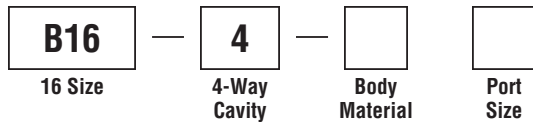

Code	Body Material
Omit	Steel
A	Aluminum

Code	Port Size
16T	SAE - 16

Form Tool: Rougher NFT16-4R
Finisher NFT16-4F
Weight: 3.75 kg (8.125 lbs.)

Valve/Cavity Compatibility

For additional information see Technical Tips on pages BC1-BC6.

		VALVE				
		Winner's Circle	Parker	Waterman	FPS	CEC
CAVITY	Winner's Circle	X	X	X	X	X
	Parker	X	X	X	X	X
	Waterman	X	X	X	X	X
	FPS	X	X	X	X	X
	CEC	X	X	X	X	X

Performance Curve

Pressure Drop vs. Flow

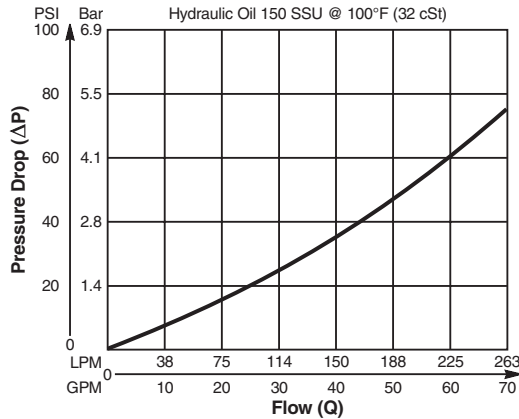

Dimensions Millimeters (Inches)

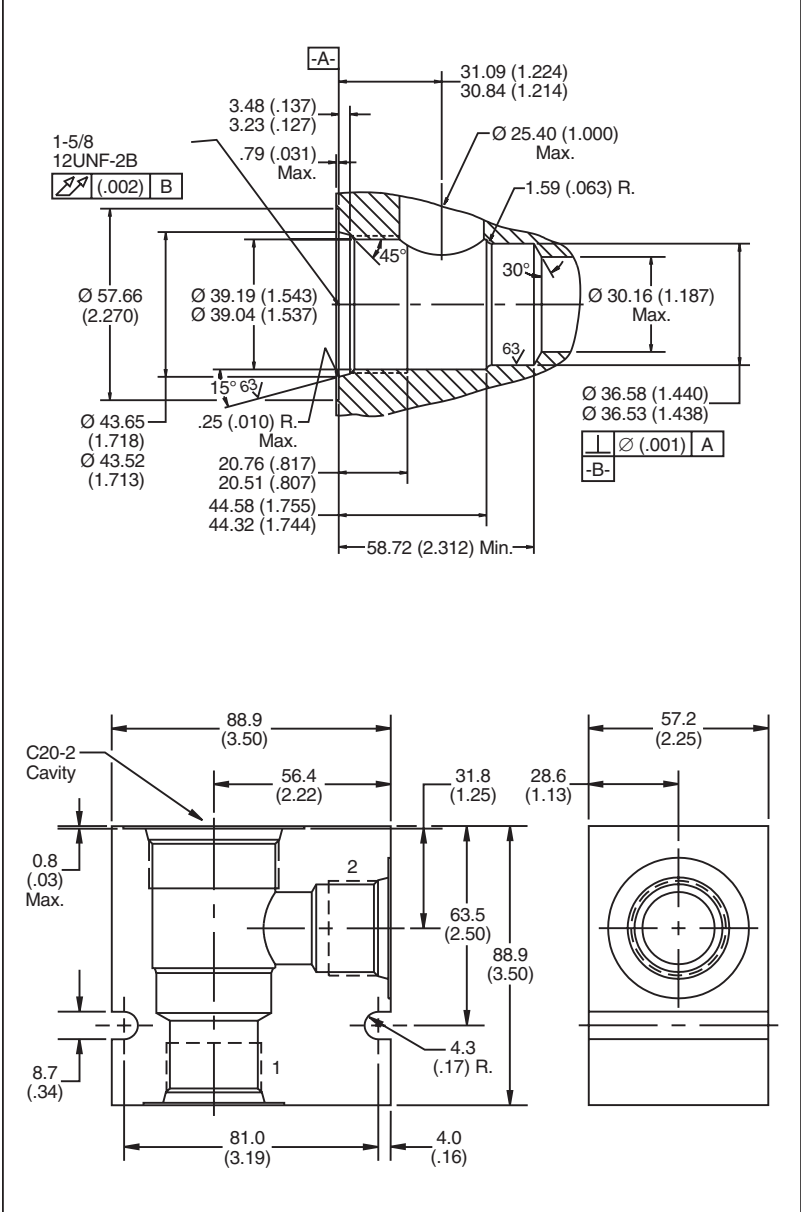

Ordering Information

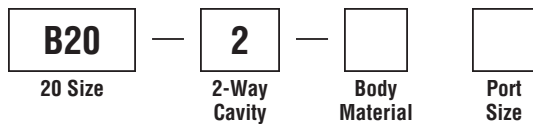

Code	Body Material
Omit	Steel

Code	Port Size
20T	SAE - 20
20B	1-1/4" BSPG

Form Tool: Rougher None
 Finisher NFT20-F
Weight: 6.3 kg (14 lbs.)

- CV** Check Valves
- SH** Shuttle Valves
- LM** Load/Motor Controls
- FC** Flow Controls
- PC** Pressure Controls
- LE** Logic Elements
- DC** Directional Controls
- MV** Manual Valves
- SV** Solenoid Valves
- PV** Proportional Valves
- CE** Coils & Electronics
- BC** Bodies & Cavities
- TD** Technical Data

- CV** Check Valves
- SH** Shuttle Valves
- LM** Load/Motor Controls
- FC** Flow Controls
- PC** Pressure Controls
- LE** Logic Elements
- DC** Directional Controls
- MV** Manual Valves
- SV** Solenoid Valves
- PV** Proportional Valves
- CE** Coils & Electronics
- BC** Bodies & Cavities
- TD** Technical Data

Valve/Cavity Compatibility

For additional information see Technical Tips on pages BC1-BC6.

		VALVE				
		Winner's Circle	Parker	Waterman	FPS	CEC
CAVITY	Winner's Circle	X				X
	Parker					
	Waterman					
	FPS					
	CEC	X				X

Performance Curve
Pressure Drop vs. Flow

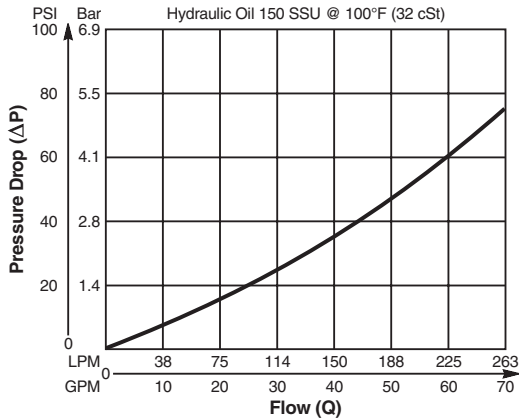

Dimensions Millimeters (Inches)

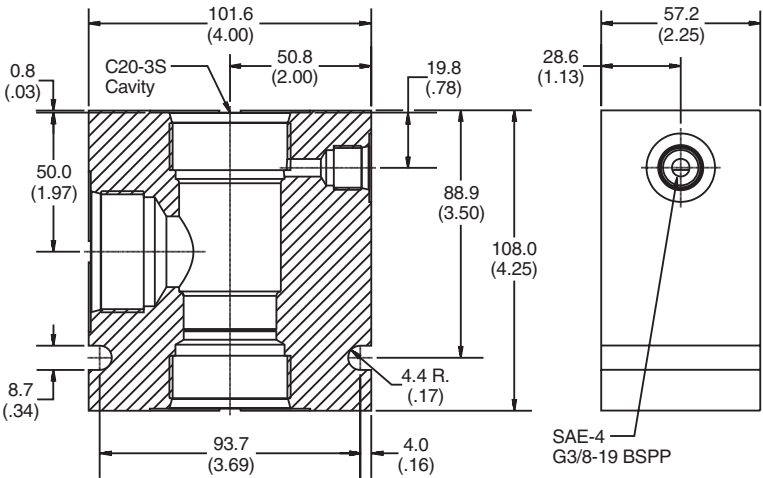
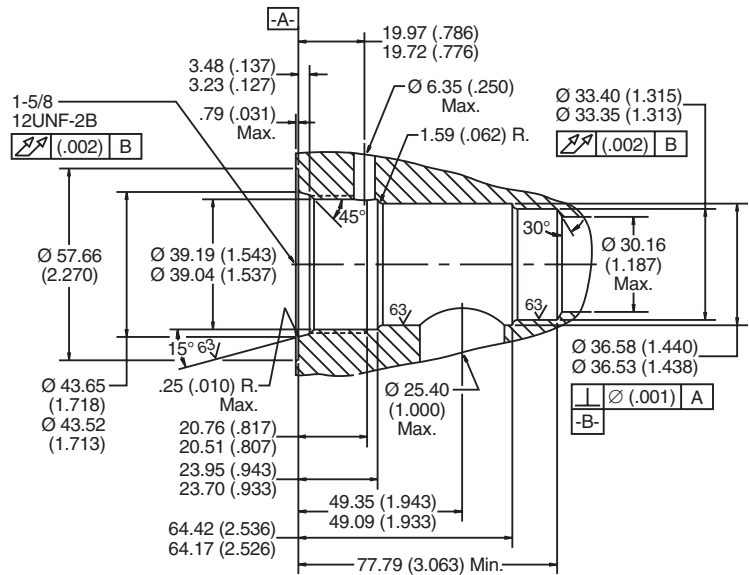

Ordering Information

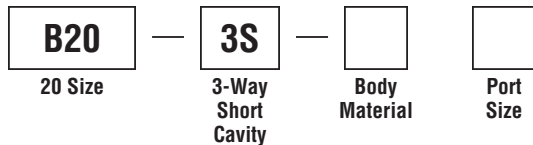

Code	Body Material	Code	Port Size
Omit	Steel	20T	SAE - 20
		20B	1-1/4" BSPG

Form Tool: Rougher NFT20S-3R
 Finisher NFT20S-3F
Weight: 10.8 kg (22.2 lbs.)

Valve/Cavity Compatibility

For additional information see Technical Tips on pages BC1-BC6.

		VALVE	
		MHC-010	2-N-4*-10
CAVITY	MHC-010	X	X
	2-N-4*-10	X	X

Ordering Information

MHC	010		53
Counterbalance Cartridge Valve	Nominal Flow Rating	Body Type	Port Size

Code	Body Type	Code	Port Size
A	Single	53	SAE-10 through port
D	Dual		

Form Tool: FR-500
Weight: Single 1.1 kg (2.25 lbs.)
 Dual 1.9 kg (4.10 lbs.)

Dimensions Millimeters (Inches)

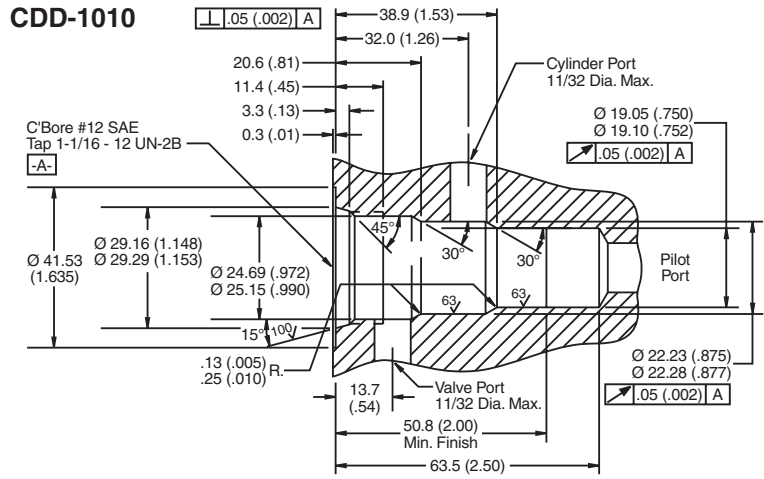

Single Body

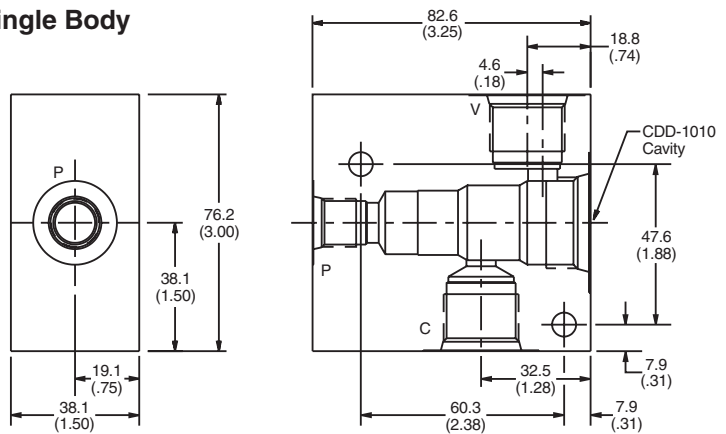

Dual Body

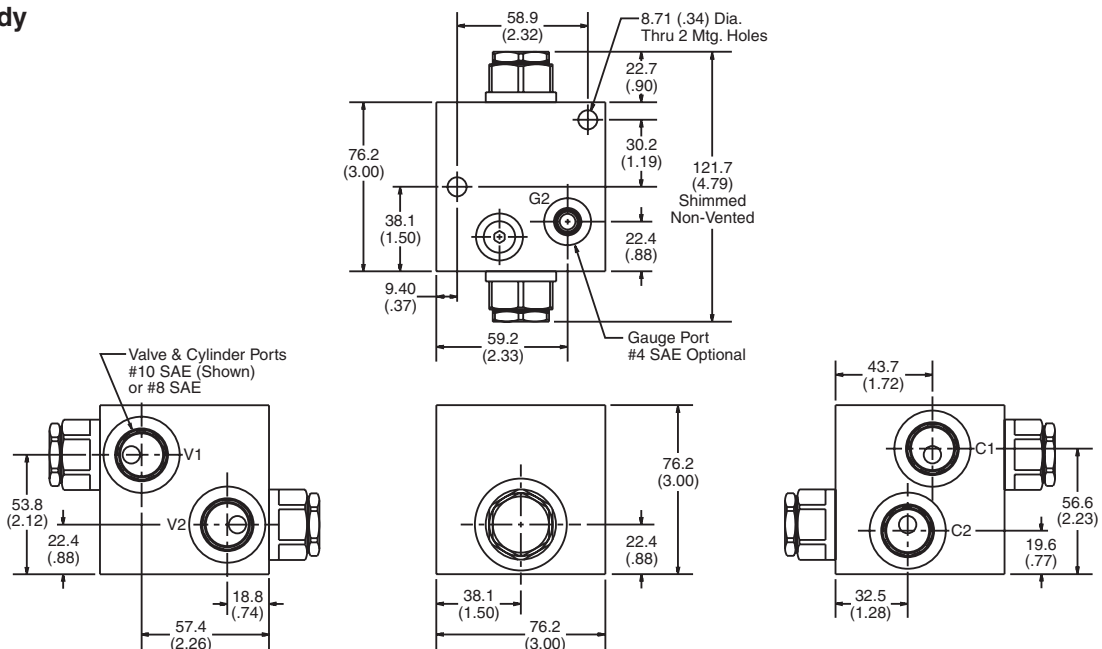

- CV** Check Valves
- SH** Shuttle Valves
- LM** Load/Motor Controls
- FC** Flow Controls
- PC** Pressure Controls
- LE** Logic Elements
- DC** Directional Controls
- MV** Manual Valves
- SV** Solenoid Valves
- PV** Proportional Valves
- CE** Coils & Electronics
- BC** Bodies & Cavities
- TD** Technical Data

- CV** Check Valves
- SH** Shuttle Valves
- LM** Load/Motor Controls
- FC** Flow Controls
- PC** Pressure Controls
- LE** Logic Elements
- DC** Directional Controls
- MV** Manual Valves
- SV** Solenoid Valves
- PV** Proportional Valves
- CE** Coils & Electronics
- BC** Bodies & Cavities
- TD** Technical Data

Valve/Cavity Compatibility

For additional information see Technical Tips on pages BC1-BC6.

		VALVE	
		MHC-022	2-N-4*-25
CAVITY	MHC-022	X	X
	2-N-4*-25	X	X

Ordering Information

MHC — **022** — — **53**
 Counterbalance Cartridge Valve Nominal Flow Rating Body Type Port Size

Code	Body Type	Code	Port Size
A	Single	53	SAE-10 through port
D	Dual		

Form Tool: FR-501
Weight: Single 1.7 kg (3.75 lbs.)
 Dual 2.7 kg (5.90 lbs.)

Dimensions Millimeters (Inches)

CDD-1036

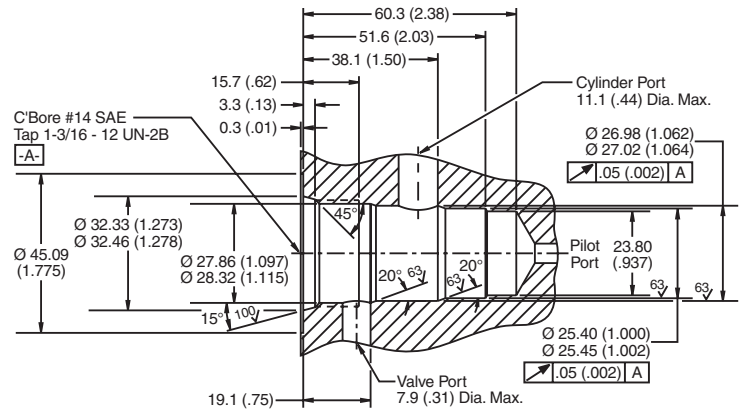

Single Body

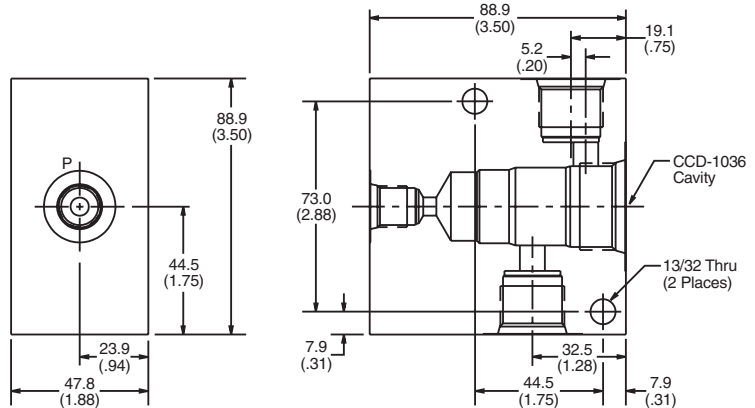

Dual Body

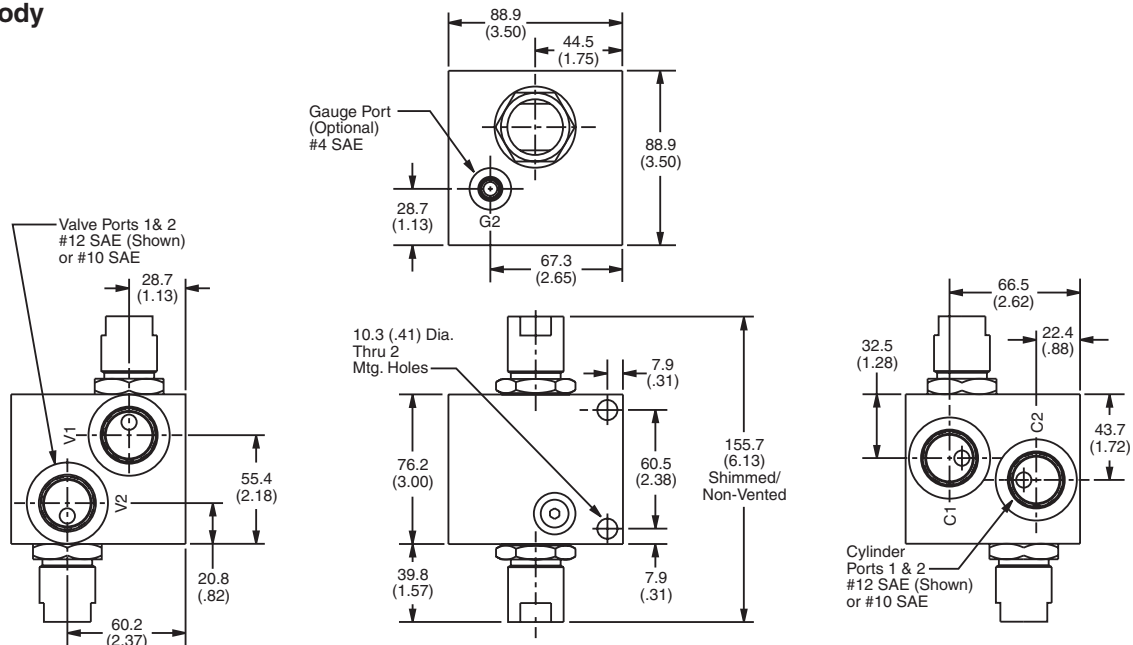

Valve/Cavity Compatibility

For additional information see Technical Tips on pages BC1-BC6.

		VALVE	
		MHC-025	2-N-4*-50
CAVITY	MHC-025	X	X
	2-N-4*-50	X	X

Ordering Information

MHC — **025** — **54**
 Counterbalance Cartridge Valve Nominal Flow Rating Body Type Port Size

Code	Body Type	Code	Port Size
A	Single	54	SAE-12 through port
D	Dual		

Form Tool: Drill FD-291
 Reamer FR-105
Weight: Single 3.3 kg (7.25 lbs.)
 Dual 5.4 kg (11.90 lbs.)

Dimensions Millimeters (Inches)

CDD-1012

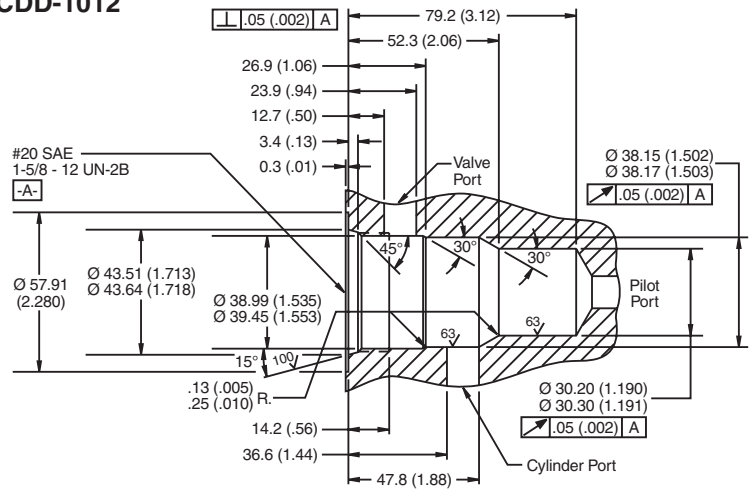

Single Body

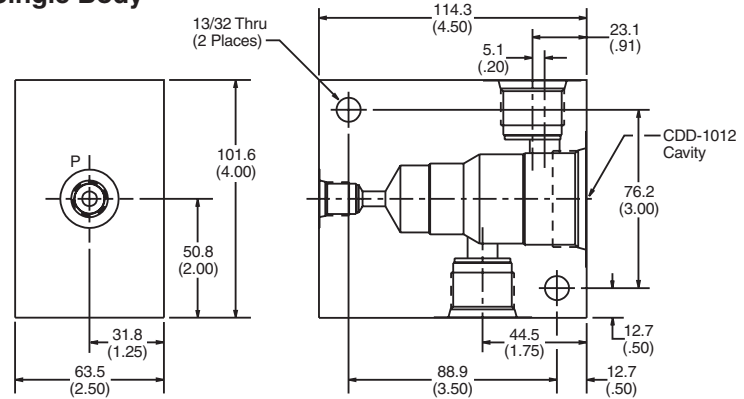

Dual Body

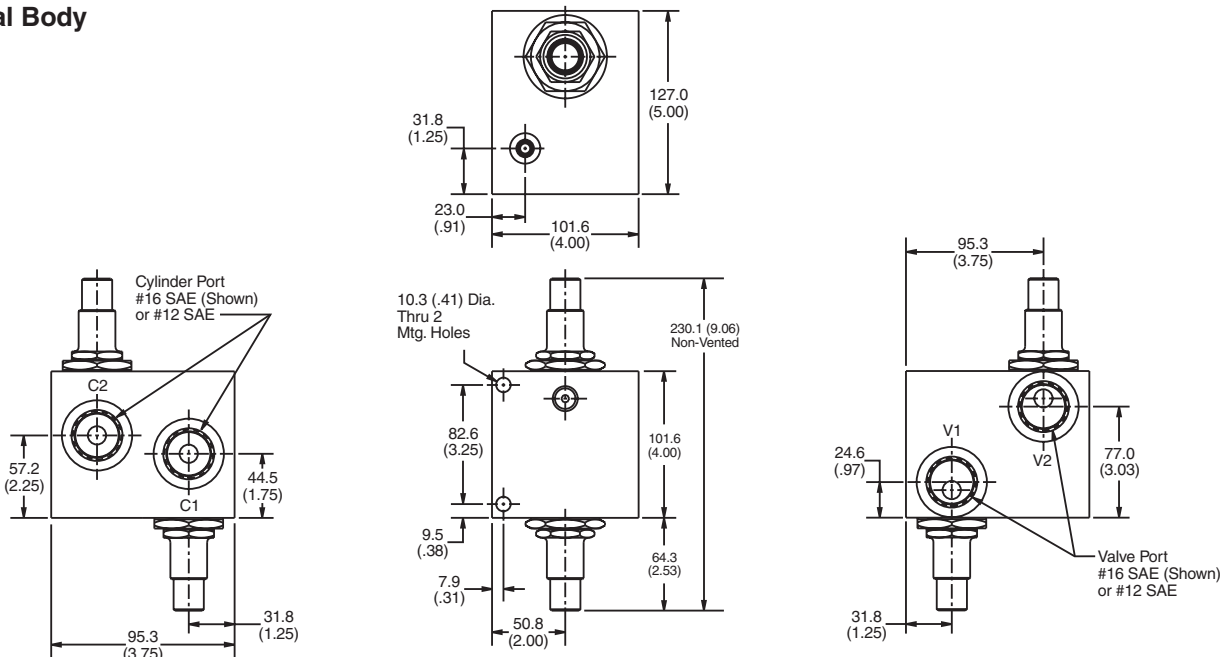

- CV** Check Valves
- SH** Shuttle Valves
- LM** Load/Motor Controls
- FC** Flow Controls
- PC** Pressure Controls
- LE** Logic Elements
- DC** Directional Controls
- MV** Manual Valves
- SV** Solenoid Valves
- PV** Proportional Valves
- CE** Coils & Electronics
- BC** Bodies & Cavities
- TD** Technical Data

- CV Check Valves
- SH Shuttle Valves
- LM Load/Motor Controls
- FC Flow Controls
- PC Pressure Controls
- LE Logic Elements
- DC Directional Controls
- MV Manual Valves
- SV Solenoid Valves
- PV Proportional Valves
- CE Coils & Electronics
- BC Bodies & Cavities
- TD Technical Data

Valve/Cavity Compatibility

For additional information see Technical Tips on pages BC1-BC6.

		VALVE	
		MHC-050	2-N-4*-100
CAVITY	MHC-050	X	X
	2-N-4*-100	X	X

Ordering Information

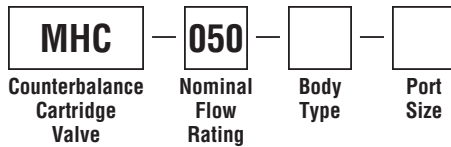

Code	Body Type	Code	Port Size
A	Single	54	SAE-12 through port
D	Dual	56	SAE-16 through port

Form Tool: Drill FD-813
Reamer FR-231
Weight: Single 5.5 kg (12.00 lbs.)
Dual 10.8 kg (23.85 lbs.)

Dimensions Millimeters (Inches)

CDD-1013

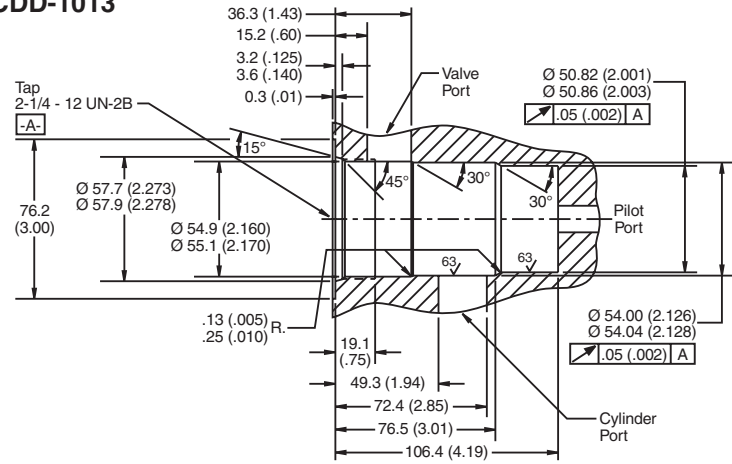

Single Body

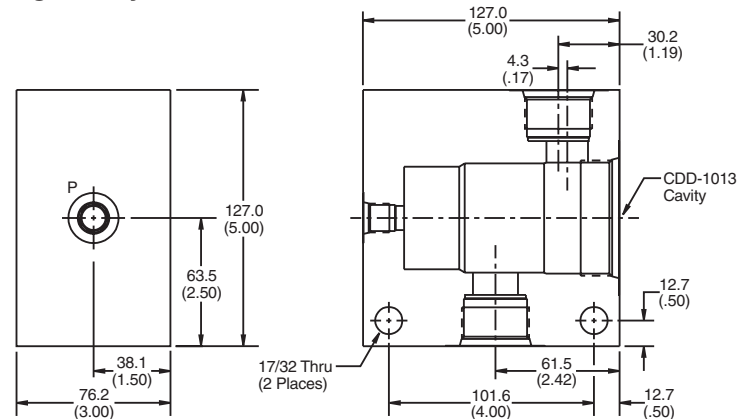

Dual Body

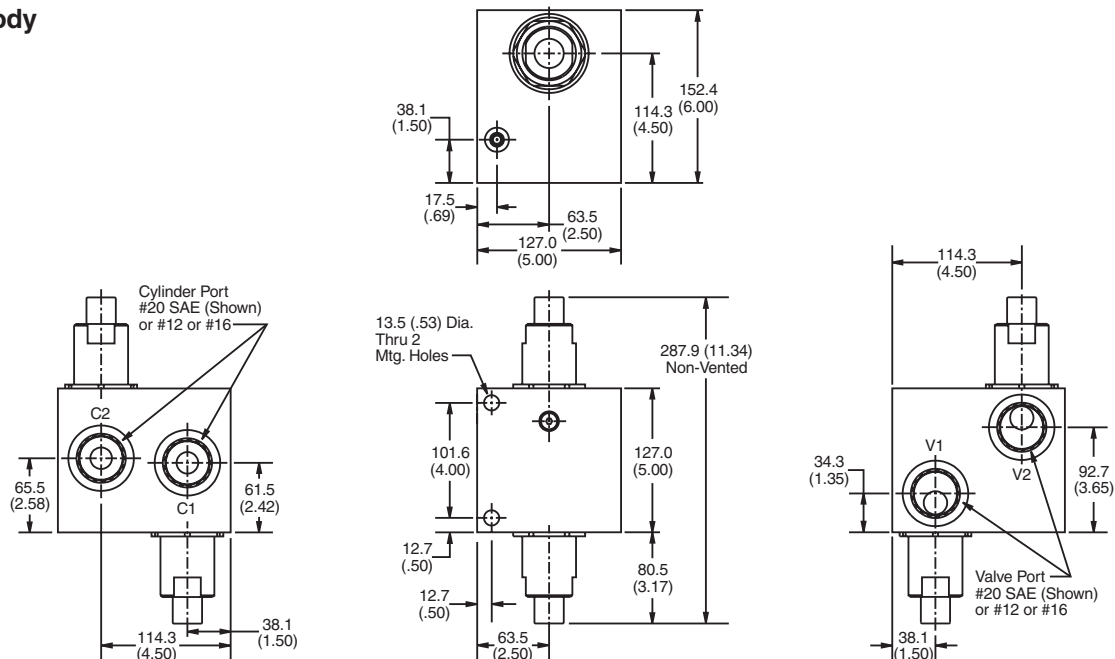

Dimensions Millimeters (Inches)

**10 Size Cavity for Single
 Check and Pilot Piston**

For Check Valve Use
 CVH103P**

For Pilot Piston Use
 717909 No Seal
 717909N Buna-N
 717909V Fluorocarbon

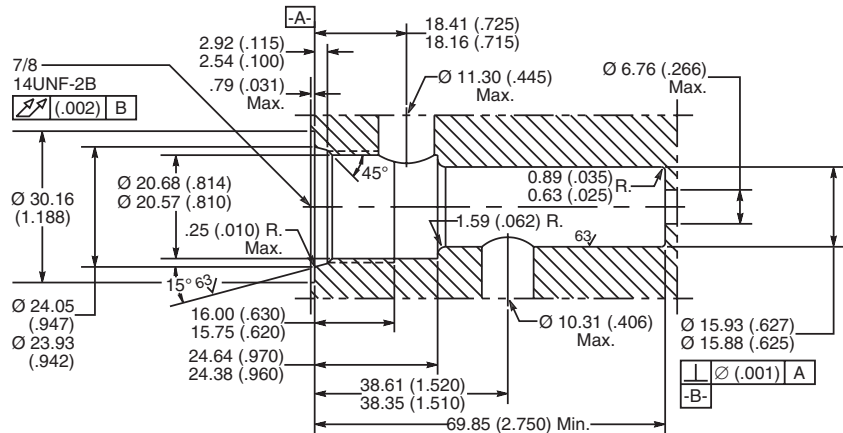

**16 Size Cavity for Single
 Check and Pilot Piston**

For Check Valve Use
 CVH161P**

For Pilot Piston Use
 717910 No Seal
 717910N Buna-N
 717910V Fluorocarbon

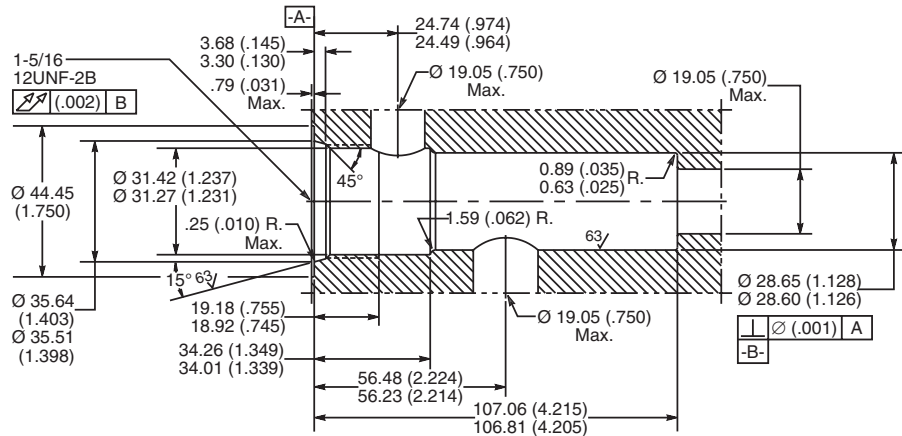

**10 Size Cavity for Dual
 Check and Pilot Piston**

For Check Valves Use 2
 CVH103P**

For Pilot Piston Use
 717917 No Seal
 717917N Buna-N
 717917V Fluorocarbon

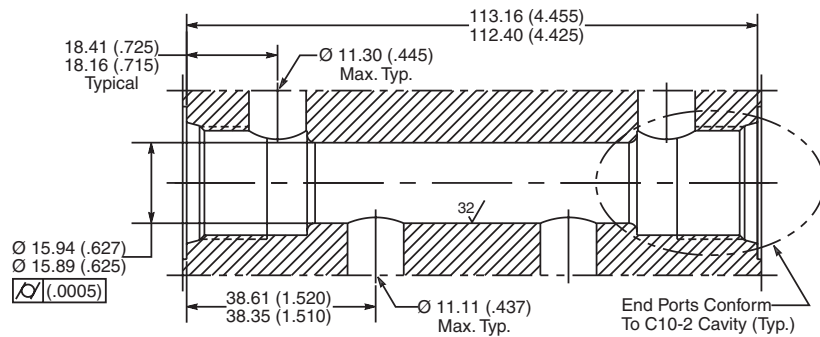

**16 Size Cavity for Dual
 Check and Pilot Piston**

For Check Valves Use 2
 CVH161P**

For Pilot Piston Use
 717918 No Seal
 717918N Buna-N
 717918V Fluorocarbon

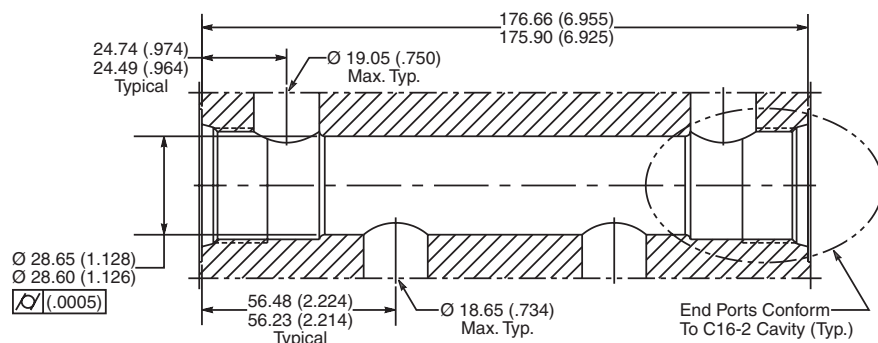

- CV** Check Valves
- SH** Shuttle Valves
- LM** Load/Motor Controls
- FC** Flow Controls
- PC** Pressure Controls
- LE** Logic Elements
- DC** Directional Controls
- MV** Manual Valves
- SV** Solenoid Valves
- PV** Proportional Valves
- CE** Coils & Electronics
- BC** Bodies & Cavities
- TD** Technical Data

- CV** Check Valves
- SH** Shuttle Valves
- LM** Load/Motor Controls
- FC** Flow Controls
- PC** Pressure Controls
- LE** Logic Elements
- DC** Directional Controls
- MV** Manual Valves
- SV** Solenoid Valves
- PV** Proportional Valves
- CE** Coils & Electronics
- BC** Bodies & Cavities
- TD** Technical Data

General Description

Parker cavity plugs can be used in any Integrated Hydraulic Circuit where one valve serves several machines and/or options. Two machines may have identical circuits except for one having a pressure reducing function, and the other not having this function. The machine that does not require this function can have the pressure reducing function replaced by a cavity plug; thereby utilizing a common body for both machines.

Specifications

Maximum Working Pressure - 350 Bar (5000 PSI)
Material - Steel

Symbols

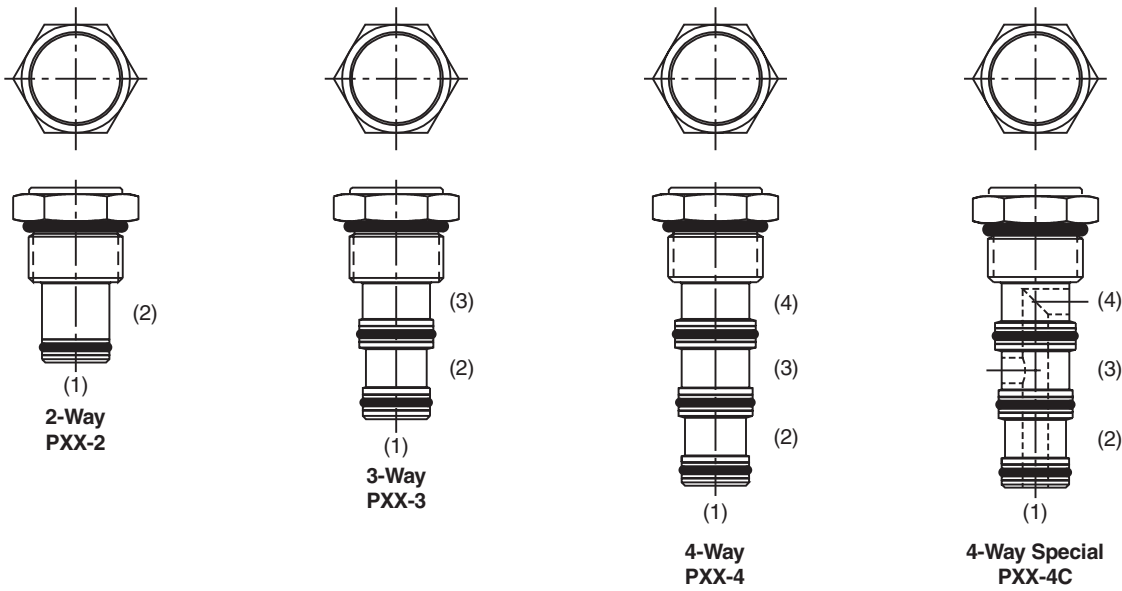
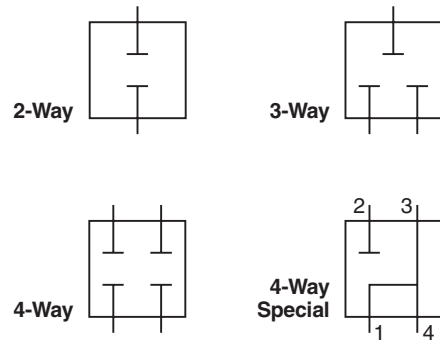

Ordering Information

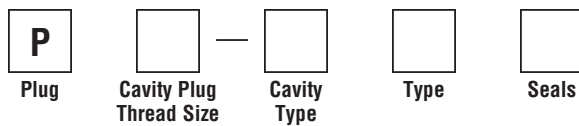

Code	Cavity Plug Thread Size
08*	3/4 - 16
10	7/8 - 14
12	1-1/16 - 12
16	1-5/16 - 12

Code	Cavity Type
2	Two Way
3	Three Way
4	Four Way

Code	Type								
	Two Way		Three Way			Four Way			
	1	2	1	2	3	1	2	3	4
Omit	C	C	C	C	C	C	C	C	C
A			O	O	C	O	O	O	C
B			O	C	O	O	O	C	O
C			C	O	O	O	C	O	O
D						*O	*O	*C	*C

Code	Seals
Omit	Nitrile
V	Fluorocarbon

* 08 Nose Diameter = 1/2"
Consult Factory for Shaded Areas.

C = Blocked O = Open
* Only Available In Sizes 08 and 10.
Consult Factory for Shaded Areas.

General Description

P Port Interrupt, 2-Way, D03 Cartpak Body.
 For additional information see Technical Tips on pages BC1-BC6.

Body Schematic

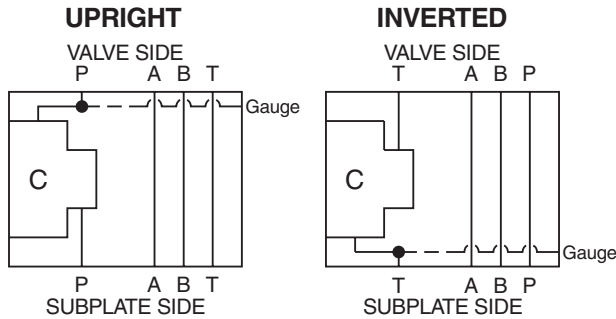

Ordering Information

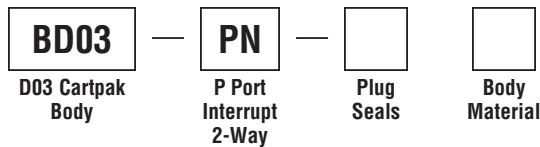

Code	Plug Seals
Omit	Nitrile
V	Fluorocarbon

Code	Body Material
A	Aluminum
S	Steel (Ductile Iron)

Body supplied with:

- Gage Port Plug Installed
- O-Ring Plate, O-Rings and Drive Pin Kit

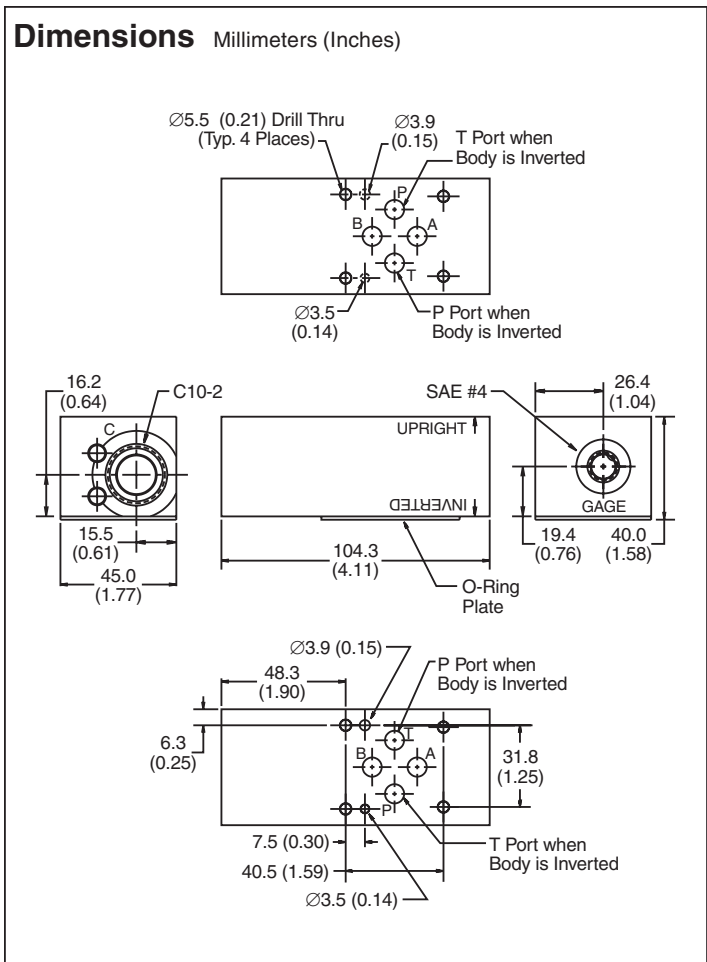

Cavity C: CVH103P CV102P	Cavity C: FR101 FC101 (has check)	Cavity C: HP04P	Cavity C: CVH103P CV102P
Direction: Upright	Direction: Upright	Direction: Upright	Direction: Inverted

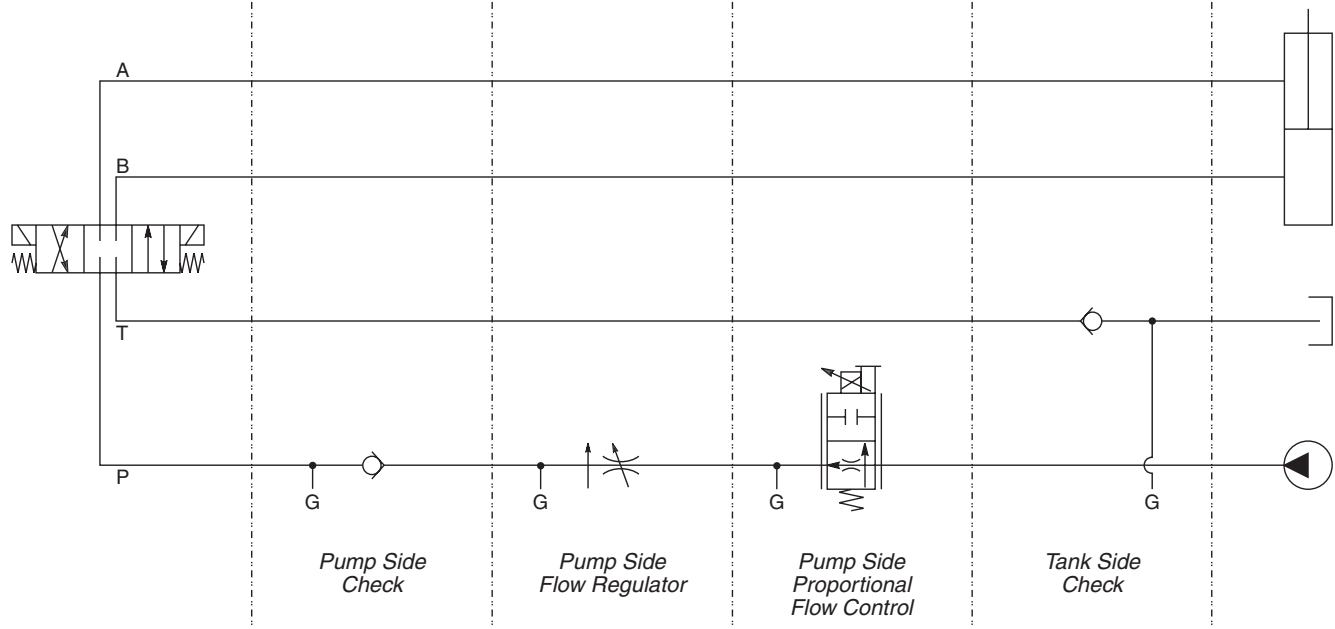

- CV** Check Valves
- SH** Shuttle Valves
- LM** Load/Motor Controls
- FC** Flow Controls
- PC** Pressure Controls
- LE** Logic Elements
- DC** Directional Controls
- MV** Manual Valves
- SV** Solenoid Valves
- PV** Proportional Valves
- CE** Coils & Electronics
- BC** Bodies & Cavities
- TD** Technical Data

- CV** Check Valves
- SH** Shuttle Valves
- LM** Load/Motor Controls
- FC** Flow Controls
- PC** Pressure Controls
- LE** Logic Elements
- DC** Directional Controls
- MV** Manual Valves
- SV** Solenoid Valves
- PV** Proportional Valves
- CE** Coils & Electronics
- BC** Bodies & Cavities
- TD** Technical Data

General Description

P Port Interrupt, 2-Way, D03 Cartpak Body.
 For additional information see Technical Tips on pages BC1-BC6.

Body Schematic

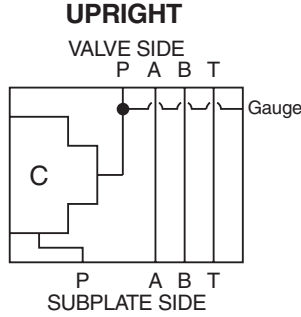

Ordering Information

BD03	—	PN2	—	□	□
D03 Cartpak Body		P Port Interrupt 2-Way		Plug Seals	Body Material
Code	Plug Seals	Code	Body Material		
Omit	Nitrile	A	Aluminum		
V	Fluorocarbon	S	Steel (Ductile Iron)		

- Body supplied with:**
- Gage Port Plug Installed
 - O-Ring Plate, O-Rings and Drive Pin Kit

Dimensions Millimeters (Inches)

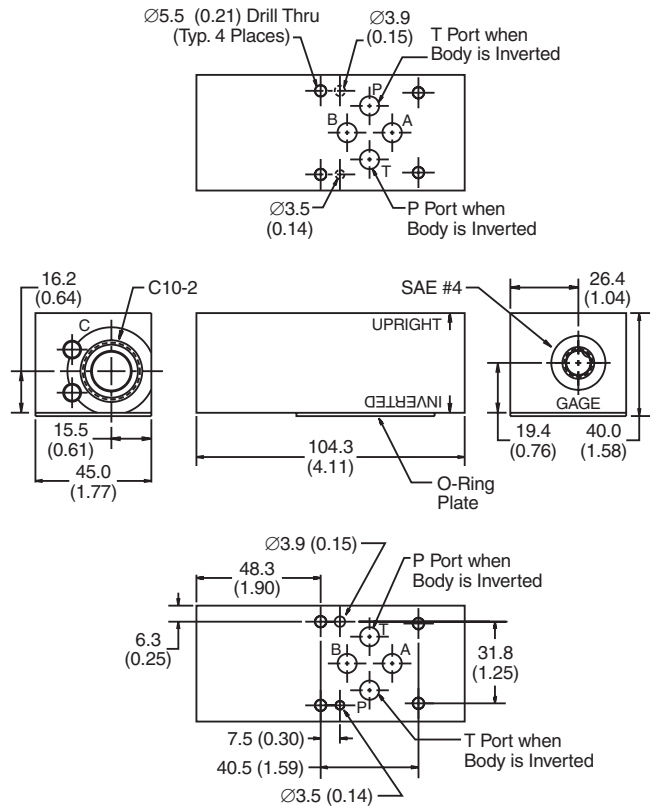

Cavity C: DSL101*
 DSH101*

Direction: Upright

Cavity C: NVH101
 FV101

Direction: Upright

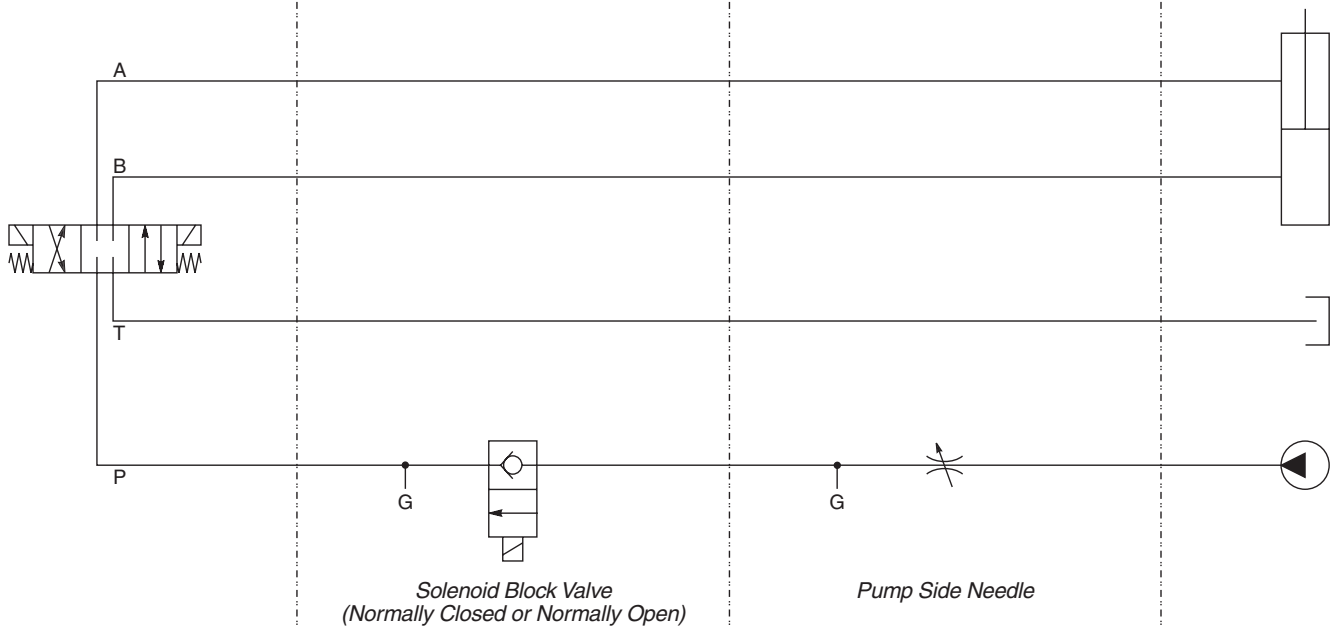

General Description

P Port Interrupt, Reducing Function, D03 Cartpak Body. For additional information see Technical Tips on pages BC1-BC6.

Body Schematic

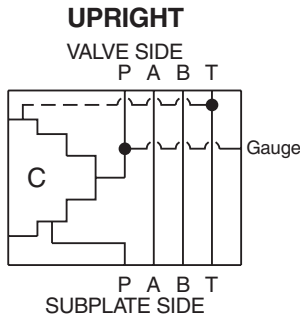

Dimensions Millimeters (Inches)

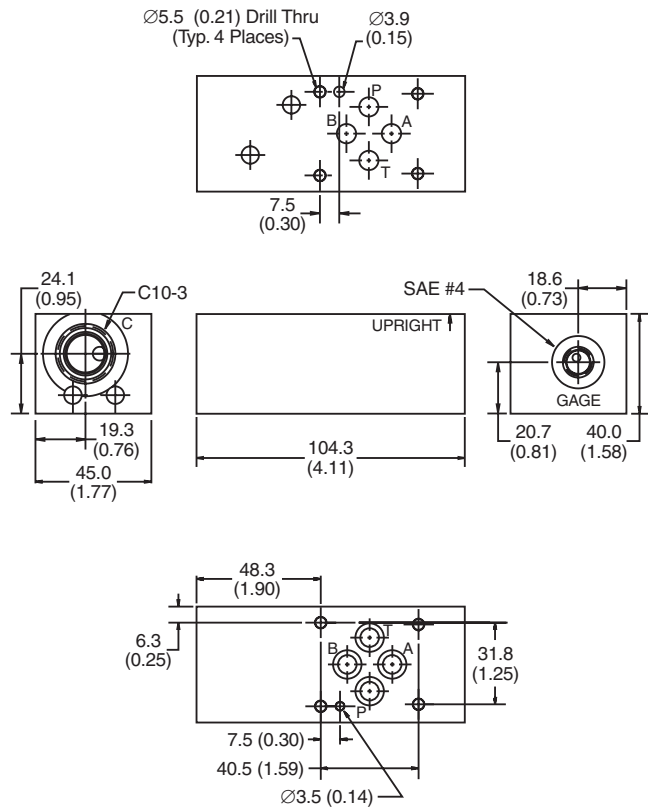

Ordering Information



Code	Plug Seals
Omit	Nitrile
V	Fluorocarbon

Code	Body Material
A	Aluminum
S	Steel (Ductile Iron)

Body supplied with:

- Gage Port Plug Installed
- O-Rings and Drive Pin

Cavity C: PRH102	Cavity C: PRH101 PR103	Cavity C: DSL103A DSH103A	Cavity C: DSL103N DSH103N
Direction: Upright	Direction: Upright	Direction: Upright	Direction: Upright

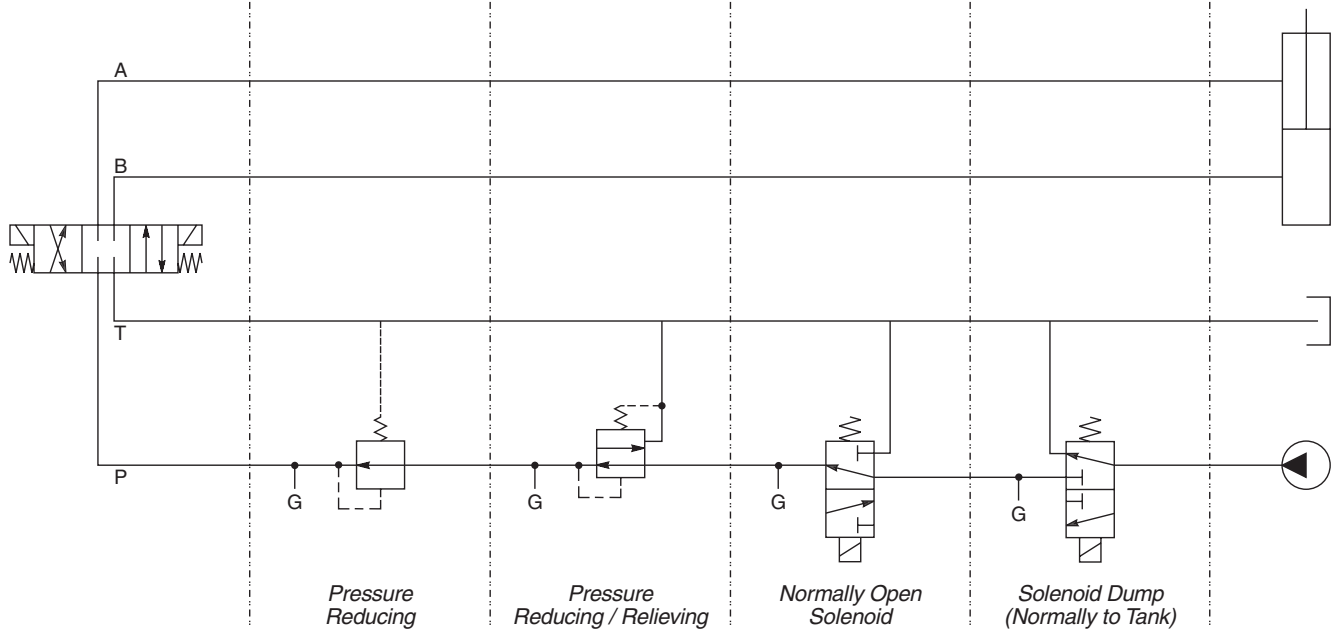

- CV** Check Valves
- SH** Shuttle Valves
- LM** Load/Motor Controls
- FC** Flow Controls
- PC** Pressure Controls
- LE** Logic Elements
- DC** Directional Controls
- MV** Manual Valves
- SV** Solenoid Valves
- PV** Proportional Valves
- CE** Coils & Electronics
- BC** Bodies & Cavities
- TD** Technical Data

General Description

P Port Interrupt, Sequence Function, D03 Cartpak Body. For additional information see Technical Tips on pages BC1-BC6.

Body Schematic

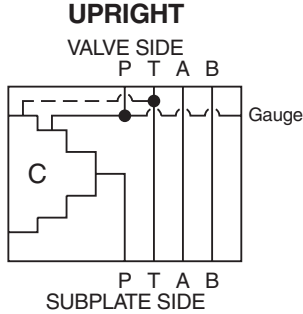

Dimensions Millimeters (Inches)

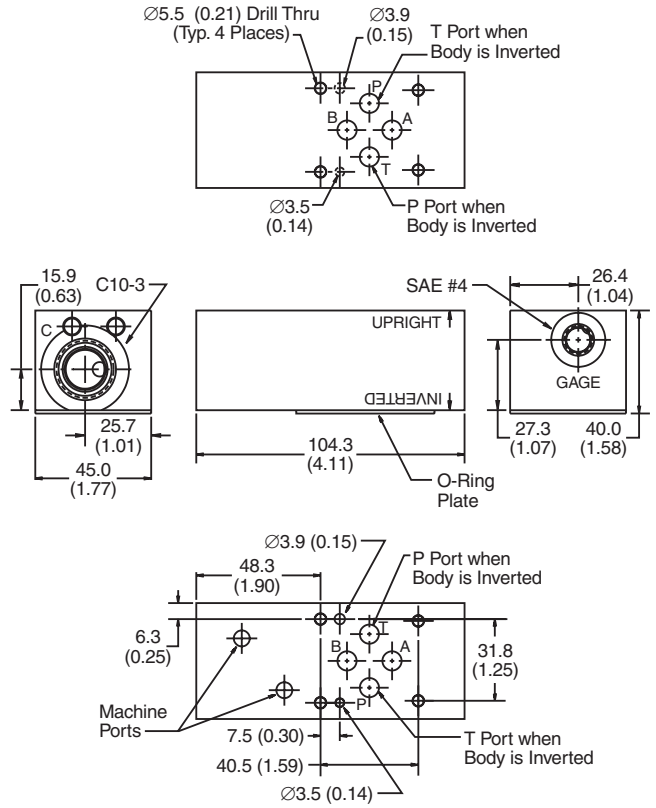

Ordering Information

BD03	—	PNS	—		—	
D03 Cartpak Body		P Port Interrupt Sequence		Plug Seals		Body Material
Code	Plug Seals		Code	Body Material		
Omit	Nitrile		A	Aluminum		
V	Fluorocarbon		S	Steel (Ductile Iron)		

- Body supplied with:**
- Gage Port Plug Installed
 - O-Ring Plate, O-Rings and Drive Pin Kit

Cavity C: SVH101
Direction: Upright

Cavity C: DSL103A
 DSH103A
Direction: Upright

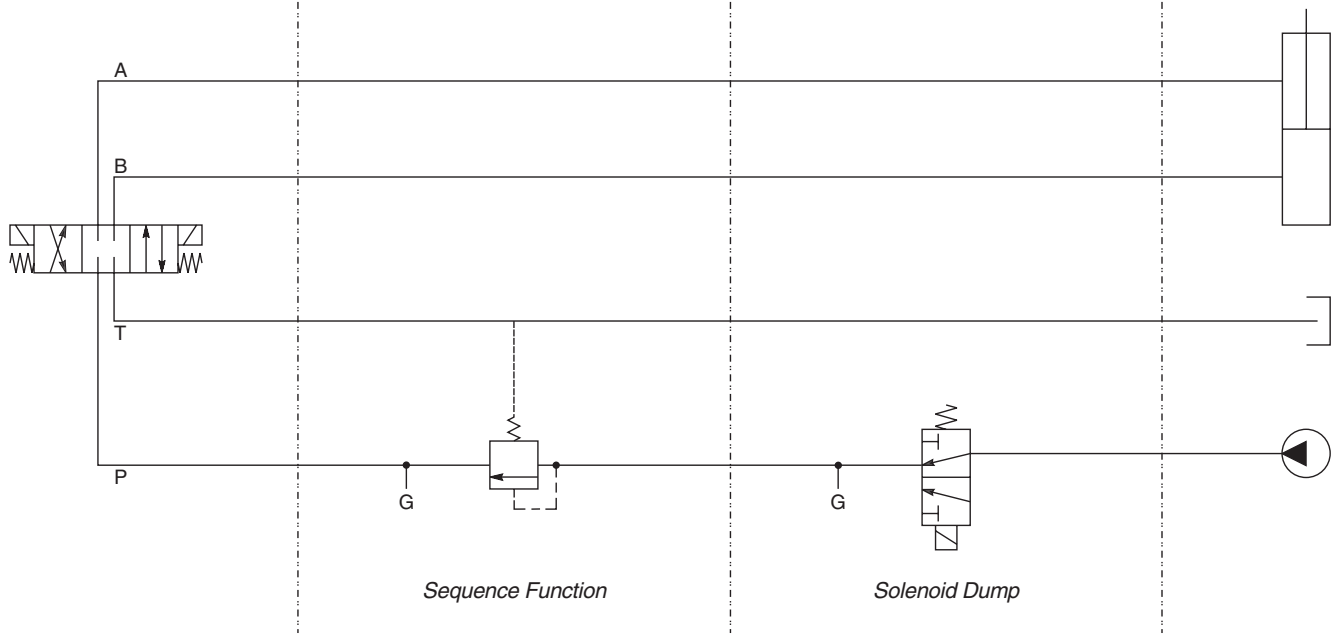

- CV** Check Valves
- SH** Shuttle Valves
- LM** Load/Motor Controls
- FC** Flow Controls
- PC** Pressure Controls
- LE** Logic Elements
- DC** Directional Controls
- MV** Manual Valves
- SV** Solenoid Valves
- PV** Proportional Valves
- CE** Coils & Electronics
- BC** Bodies & Cavities
- TD** Technical Data

General Description

P to T D03 Cartpak Body.
 For additional information see Technical Tips on pages BC1-BC6.

Body Schematic

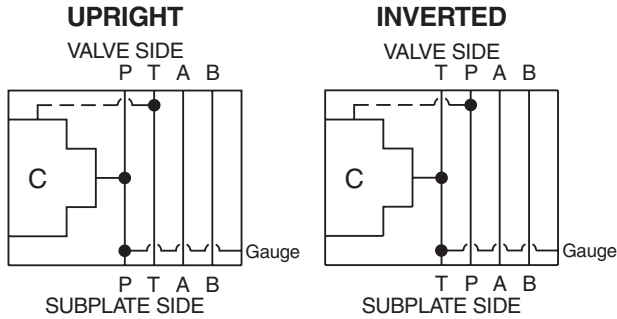

Ordering Information

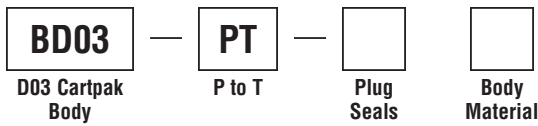

Code	Plug Seals
Omit	Nitrile
V	Fluorocarbon

Code	Body Material
A	Aluminum
S	Steel (Ductile Iron)

Body supplied with:

- Gage Port Plug Installed
- O-Ring Plate, O-Rings and Drive Pin Kit

Dimensions Millimeters (Inches)

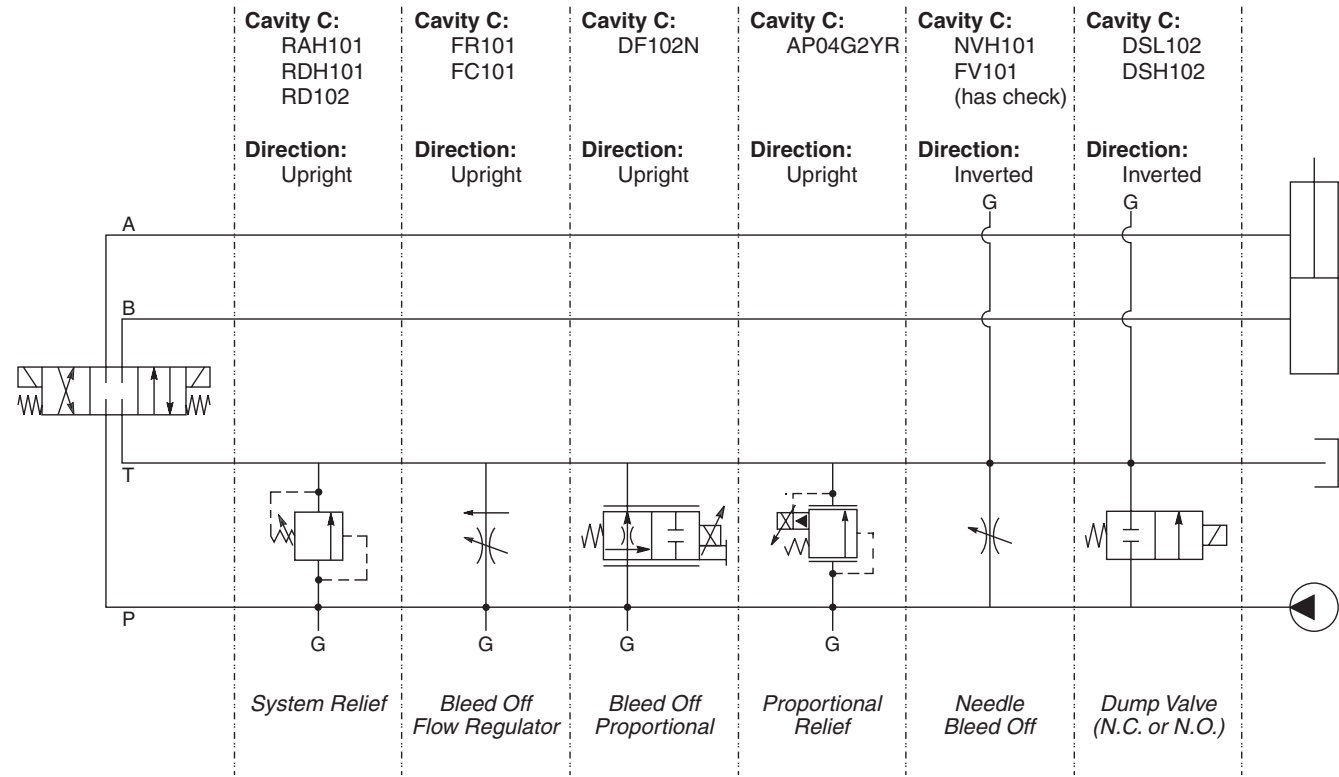
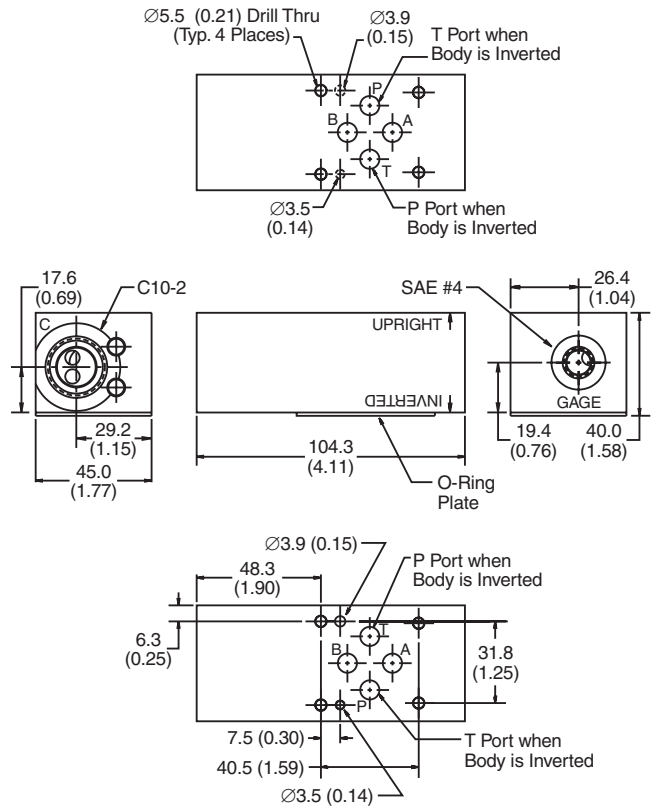

- CV** Check Valves
- SH** Shuttle Valves
- LM** Load/Motor Controls
- FC** Flow Controls
- PC** Pressure Controls
- LE** Logic Elements
- DC** Directional Controls
- MV** Manual Valves
- SV** Solenoid Valves
- PV** Proportional Valves
- CE** Coils & Electronics
- BC** Bodies & Cavities
- TD** Technical Data

- CV** Check Valves
- SH** Shuttle Valves
- LM** Load/Motor Controls
- FC** Flow Controls
- PC** Pressure Controls
- LE** Logic Elements
- DC** Directional Controls
- MV** Manual Valves
- SV** Solenoid Valves
- PV** Proportional Valves
- CE** Coils & Electronics
- BC** Bodies & Cavities
- TD** Technical Data

General Description

A and B Port Interrupt D03 Cartpak Body.
 For additional information see Technical Tips on pages BC1-BC6.

Body Schematic

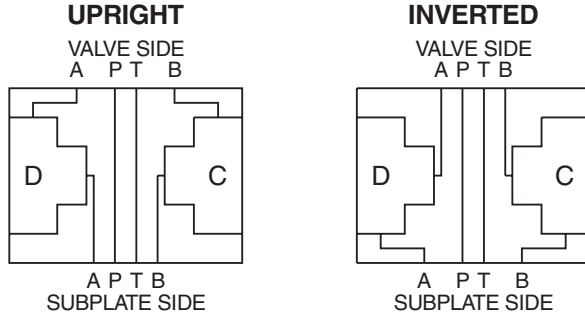

Ordering Information

BD03	ABN		
D03 Cartpak Body	A & B Port Interrupt	Plug Seals	Body Material

Code	Plug Seals	Code	Body Material
Omit	Nitrile	A	Aluminum
V	Fluorocarbon	S	Steel (Ductile Iron)

Body supplied with:
 • O-Ring Plate, O-Rings and Drive Pin Kit

Dimensions

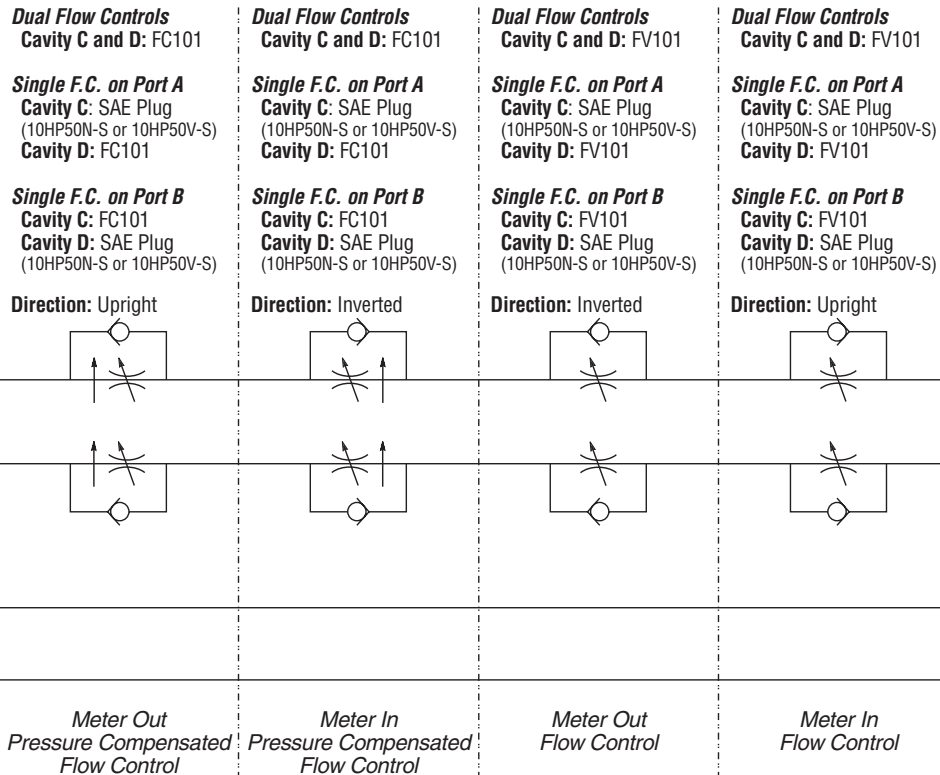
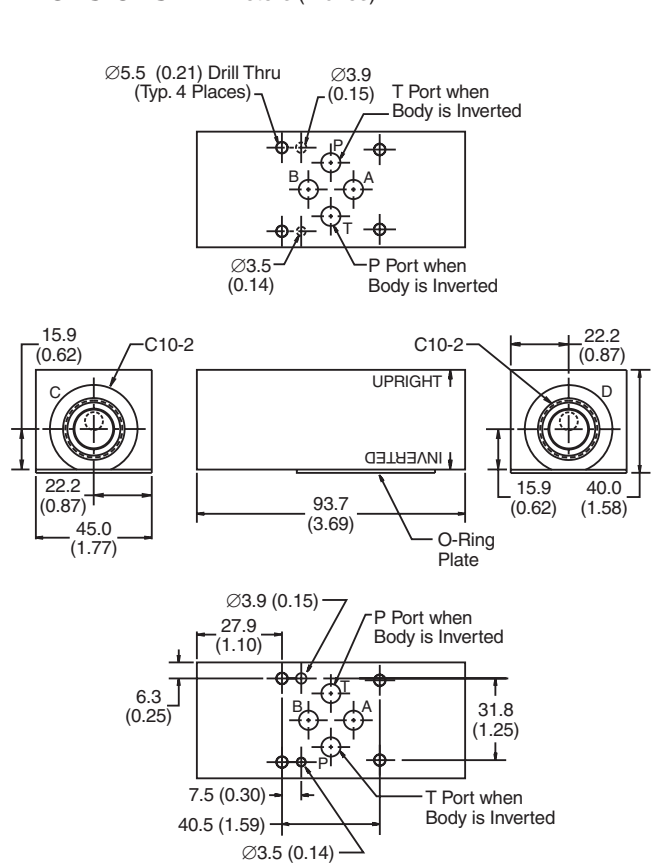

General Description

A and B Crossover D03 Cartpak Body.
 For additional information see Technical Tips on pages BC1-BC6.

Body Schematic

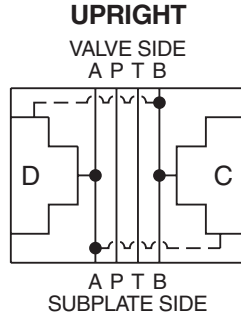

Ordering Information



Code	Plug Seals
Omit	Nitrile
V	Fluorocarbon

Code	Body Material
A	Aluminum
S	Steel (Ductile Iron)

Body supplied with:
 • O-Ring Plate, O-Rings and Drive Pin Kit

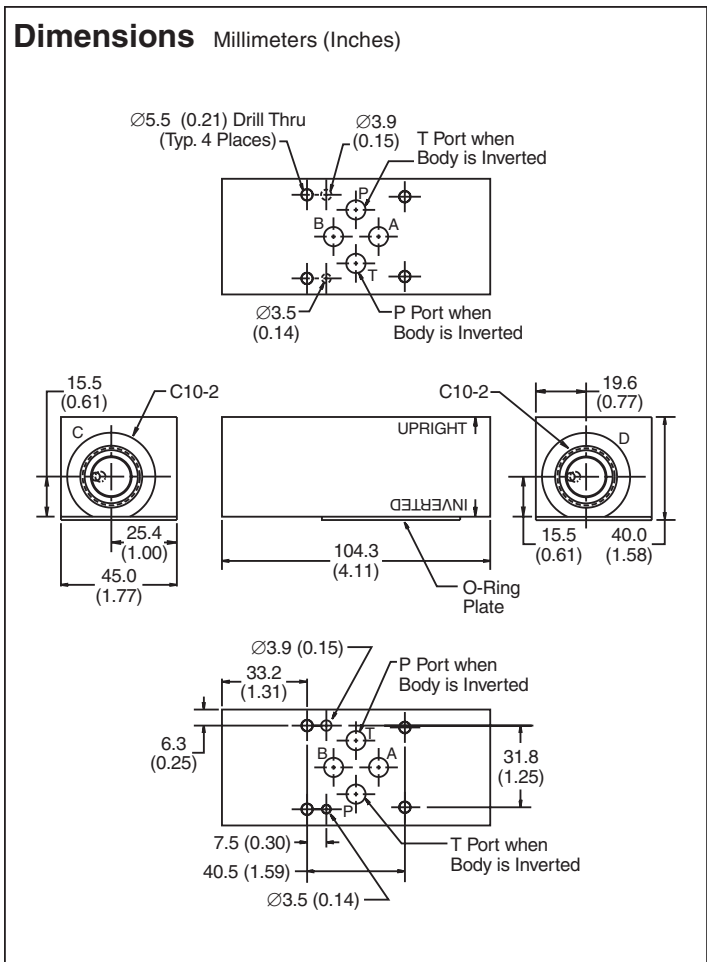

Option 1
 Cavity C: RAH101, RD102
 Cavity D: RAH101, RD102

Option 2
 Cavity C: RDH103
 Cavity D: RDH103

Direction: Upright

Option 1
 Cavity C: P10-2
 Cavity D: RDH103

Option 2
 Cavity C: RAH101, RD102
 Cavity D: P10-2

Direction: Upright

Option 1
 Cavity C: RDH103
 Cavity D: P10-2

Option 2
 Cavity C: P10-2
 Cavity D: RAH101, RD102

Direction: Upright

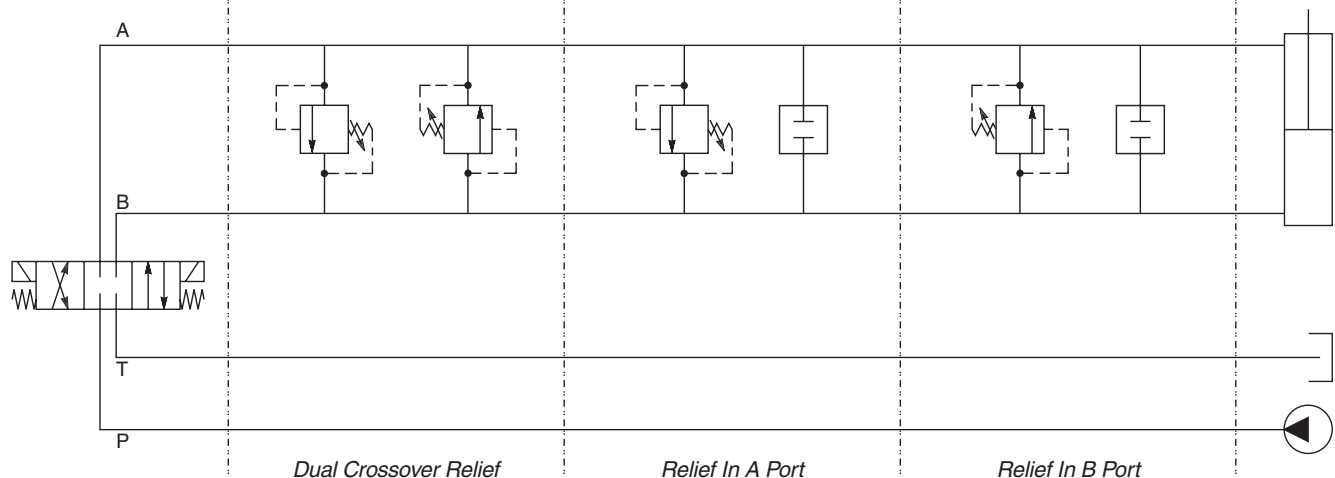

- CV** Check Valves
- SH** Shuttle Valves
- LM** Load/Motor Controls
- FC** Flow Controls
- PC** Pressure Controls
- LE** Logic Elements
- DC** Directional Controls
- MV** Manual Valves
- SV** Solenoid Valves
- PV** Proportional Valves
- CE** Coils & Electronics
- BC** Bodies & Cavities
- TD** Technical Data

- CV** Check Valves
- SH** Shuttle Valves
- LM** Load/Motor Controls
- FC** Flow Controls
- PC** Pressure Controls
- LE** Logic Elements
- DC** Directional Controls
- MV** Manual Valves
- SV** Solenoid Valves
- PV** Proportional Valves
- CE** Coils & Electronics
- BC** Bodies & Cavities
- TD** Technical Data

General Description

A and B Ports to Tank D03 Cartpak Body.
 For additional information see Technical Tips on pages BC1-BC6.

Body Schematic

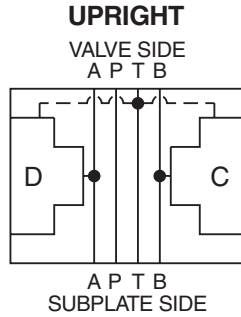

Dimensions Millimeters (Inches)

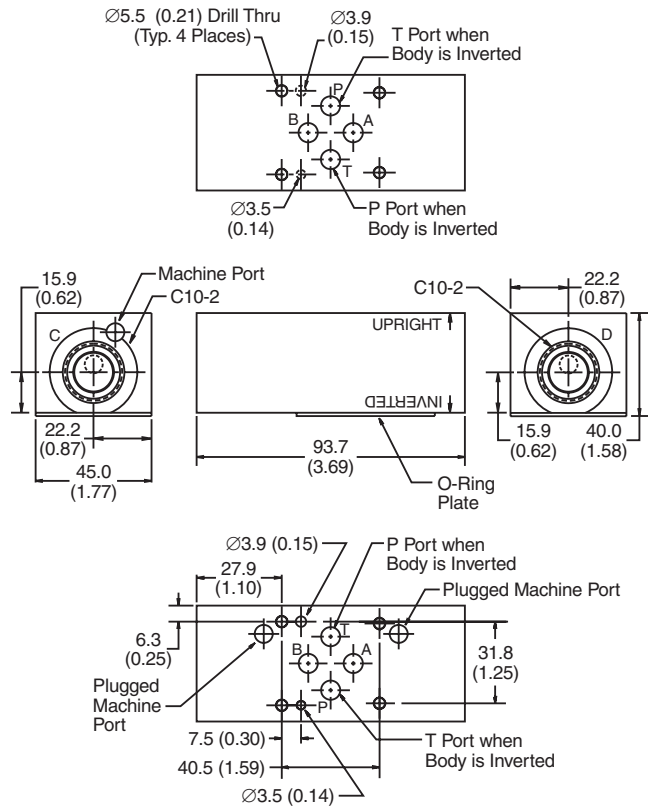

Ordering Information

BD03 D03 Cartpak Body	ABT A & B Ports to Tank	Plug Seals	Body Material
Code Plug Seals	Code Body Material		
Omit Nitrile	A Aluminum		
V Fluorocarbon	S Steel (Ductile Iron)		

Body supplied with:
 • O-Ring Plate, O-Rings and Drive Pin Kit

Dual Relief Cavity C and D: RAH101, RD102	Dual Makeup Checks Cavity C and D: CVH104P	Dual Bleed Off Cavity C and D: FR101, FC101	Dual Relief Cavity C and D: AP04G2YR	Dual Bleed Off Cavity C and D: DF102N
Relief on Port A Cavity C: P10-2 Cavity D: RAH101, RD102	Check on Port A Cavity C: P10-2 Cavity D: CVH104P	Bleed Off on Port A Cavity C: P10-2 Cavity D: FR101, FC101	Relief on Port A Cavity C: P10-2 Cavity D: AP04G2YR	Bleed Off on Port A Cavity C: P10-2 Cavity D: DF102N
Relief on Port B Cavity C: RAH101, RD102 Cavity D: P10-2	Check on Port B Cavity C: CVH104P Cavity D: P10-2	Bleed Off on Port B Cavity C: FR101, FC101 Cavity D: P10-2	Relief on Port B Cavity C: AP04G2YR Cavity D: P10-2	Bleed Off on Port B Cavity C: DF102N Cavity D: P10-2
Direction: Upright	Direction: Upright	Direction: Upright	Direction: Upright	Direction: Upright

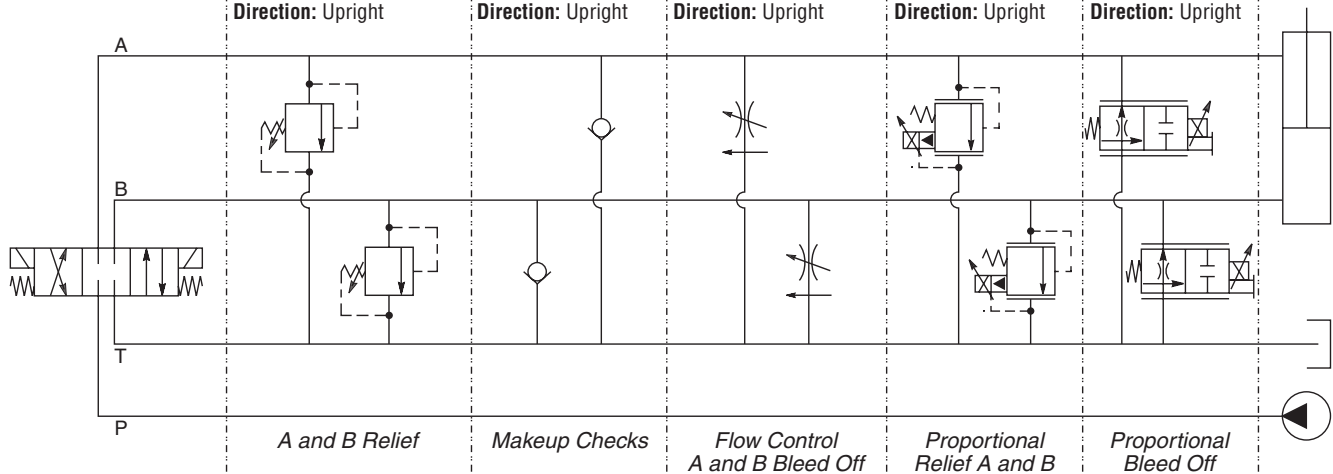

General Description

Dual (Ports A and B) Drain to Crossover Port D03 Cartpak Body. For additional information see Technical Tips on pages BC1-BC6.

Body Schematic

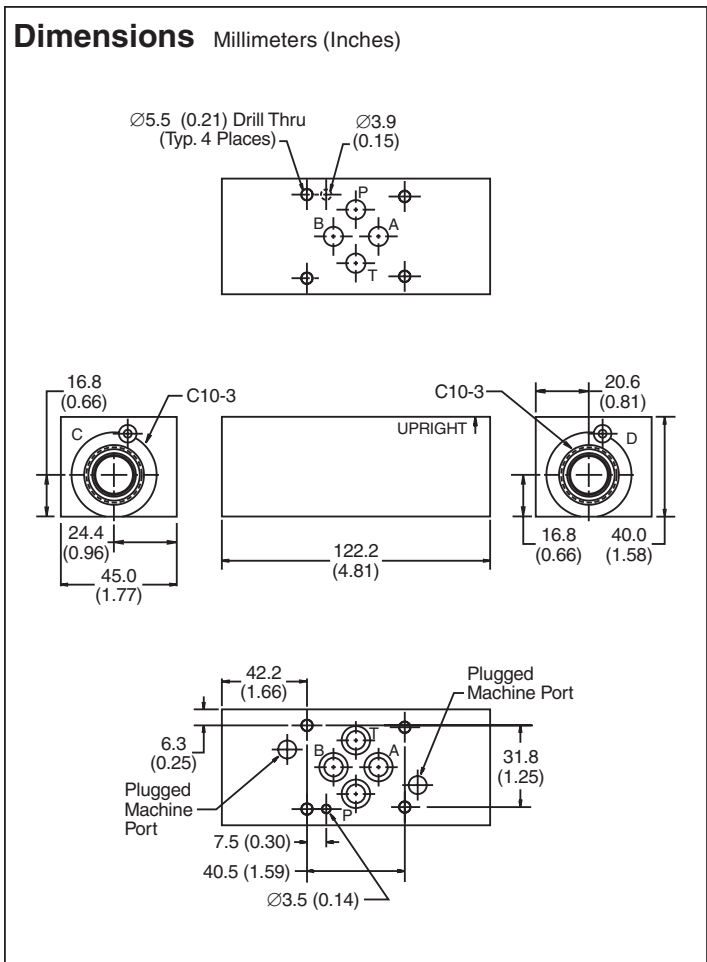
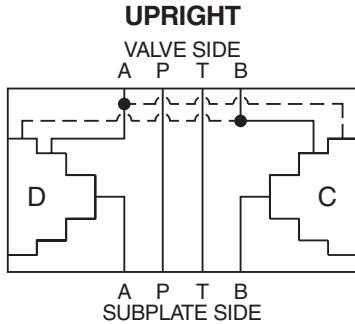

Ordering Information

BD03 D03 Cartpak Body	DDX Dual (Ports A & B) Drain to Crossover	Plug Seals	Body Material
Code Plug Seals	Code Body Material		
Omit Nitrile	A Aluminum		
V Fluorocarbon	S Steel (Ductile Iron)		

Body supplied with:
 • O-Rings and Drive Pin

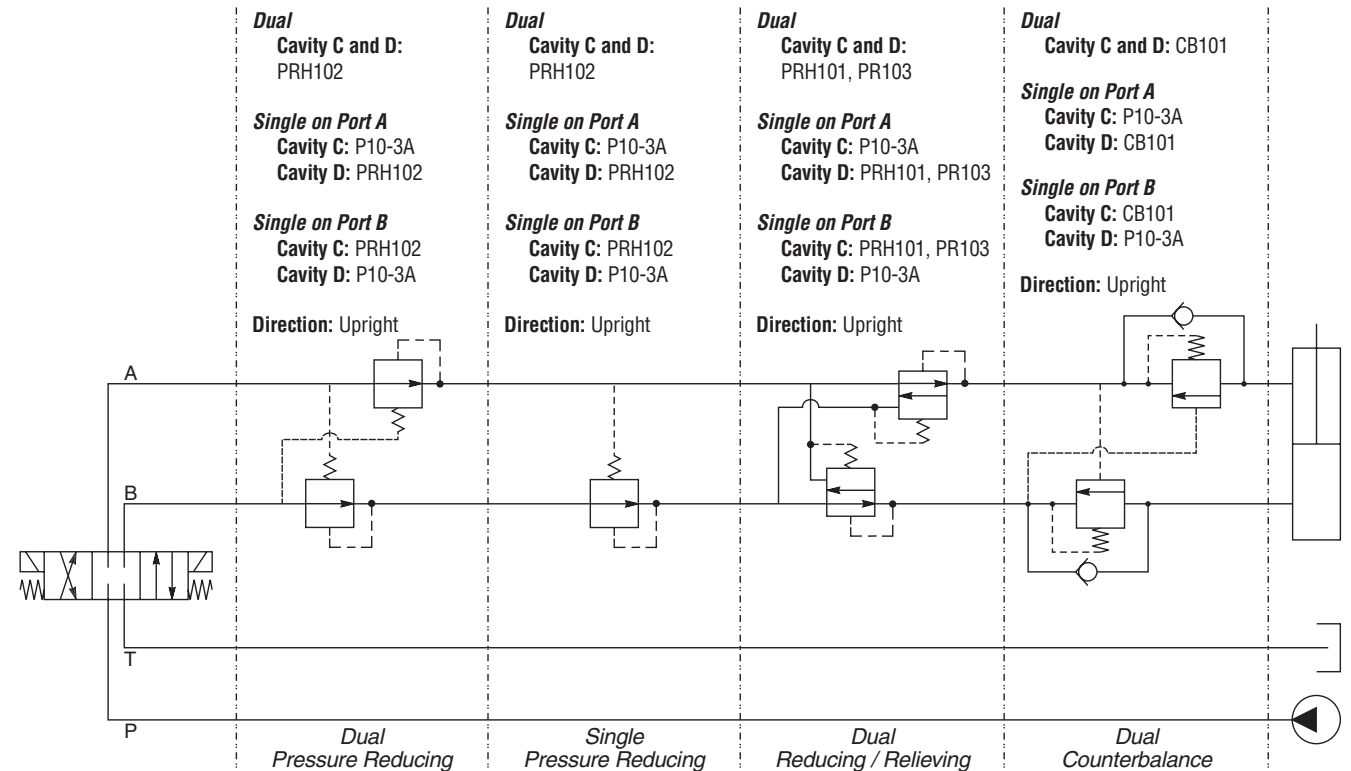

- CV** Check Valves
- SH** Shuttle Valves
- LM** Load/Motor Controls
- FC** Flow Controls
- PC** Pressure Controls
- LE** Logic Elements
- DC** Directional Controls
- MV** Manual Valves
- SV** Solenoid Valves
- PV** Proportional Valves
- CE** Coils & Electronics
- BC** Bodies & Cavities
- TD** Technical Data

- CV** Check Valves
- SH** Shuttle Valves
- LM** Load/Motor Controls
- FC** Flow Controls
- PC** Pressure Controls
- LE** Logic Elements
- DC** Directional Controls
- MV** Manual Valves
- SV** Solenoid Valves
- PV** Proportional Valves
- CE** Coils & Electronics
- BC** Bodies & Cavities
- TD** Technical Data

General Description

B Port Drain to A D03 Cartpak Body.
 For additional information see Technical Tips on pages BC1-BC6.

Body Schematic

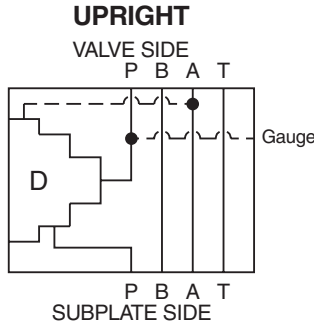

Dimensions Millimeters (Inches)

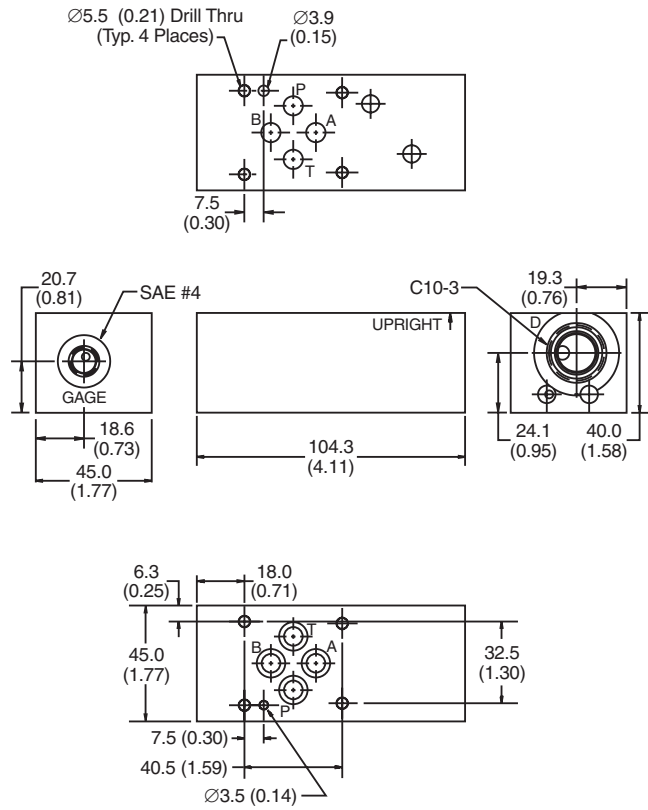

Ordering Information

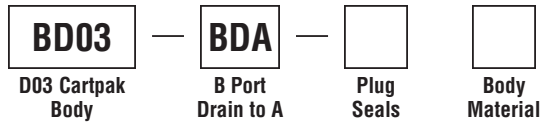

Code	Plug Seals
Omit	Nitrile
V	Fluorocarbon

Code	Body Material
A	Aluminum
S	Steel (Ductile Iron)

Body supplied with:

- Gage Port Plug Installed
- O-Rings and Drive Pin

Cavity D: PRH102

Direction: Upright

Cavity D: PRH101
PR103

Direction: Upright

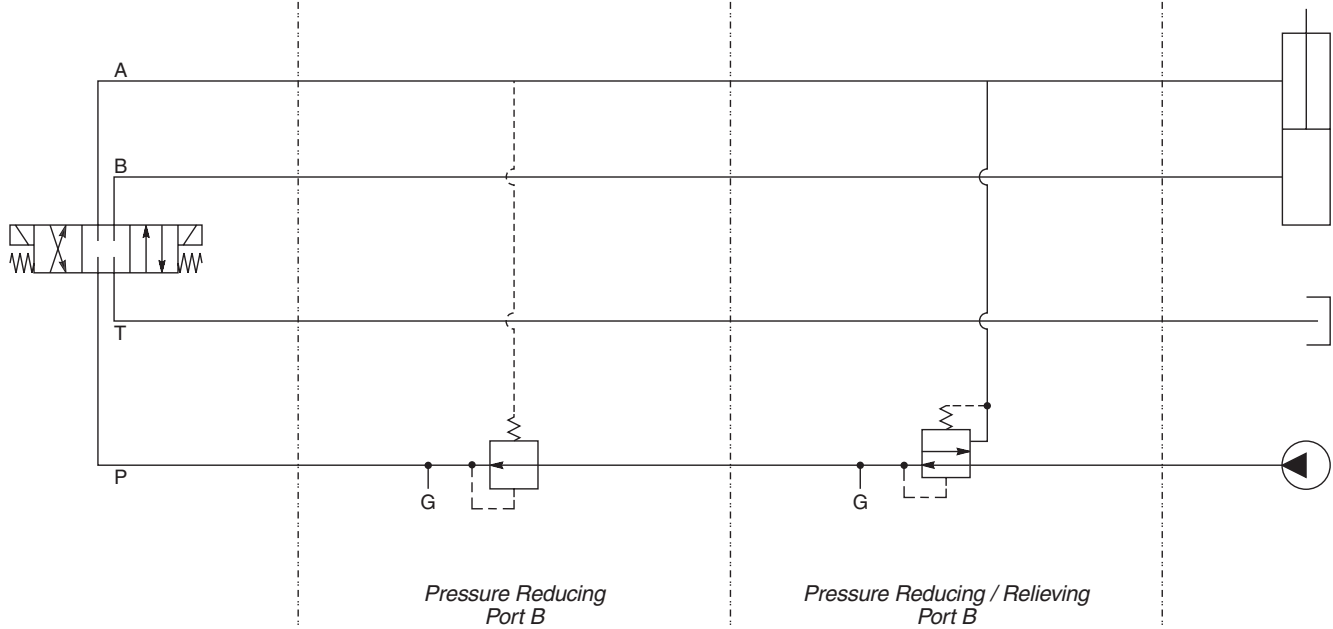

General Description

A Port Drain to B D03 Cartpak Body.
 For additional information see Technical Tips on pages BC1-BC6.

Body Schematic

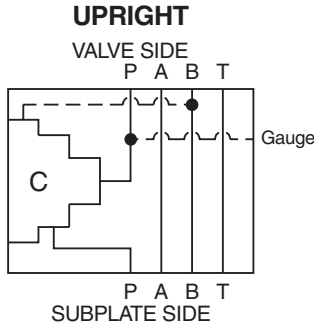

Ordering Information

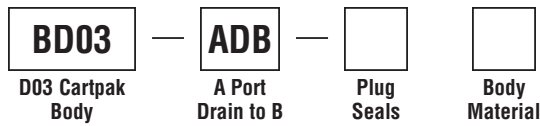

Code	Plug Seals
Omit	Nitrile
V	Fluorocarbon

Code	Body Material
A	Aluminum
S	Steel (Ductile Iron)

- Body supplied with:**
- Gage Port Plug Installed
 - O-Rings and Drive Pin

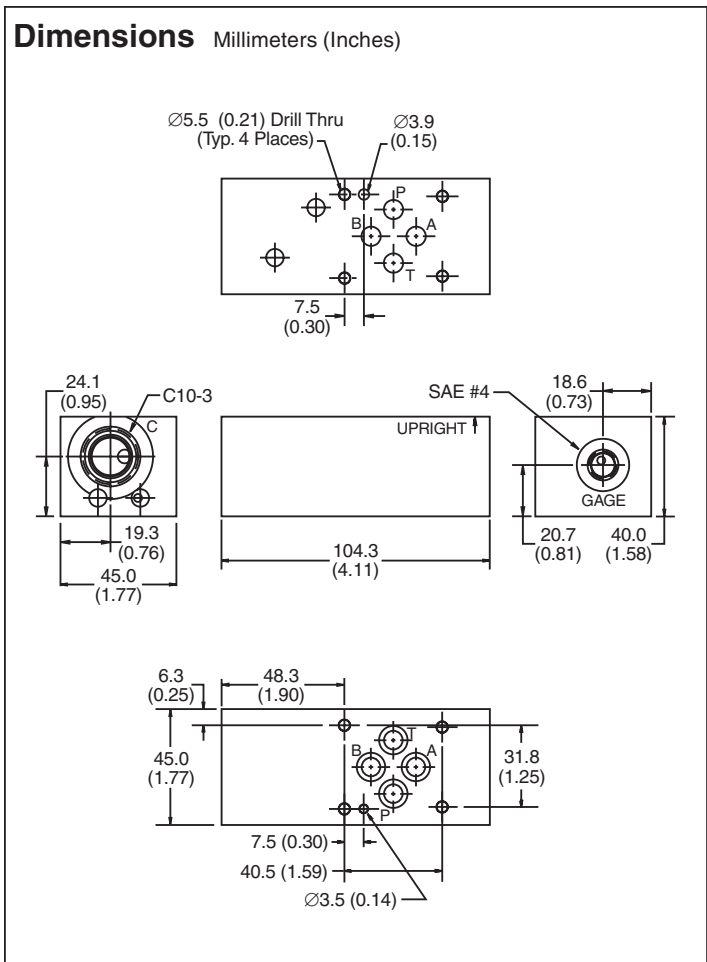

Cavity C: PRH102

Direction: Upright

Cavity C: PRH101
 PR103

Direction: Upright

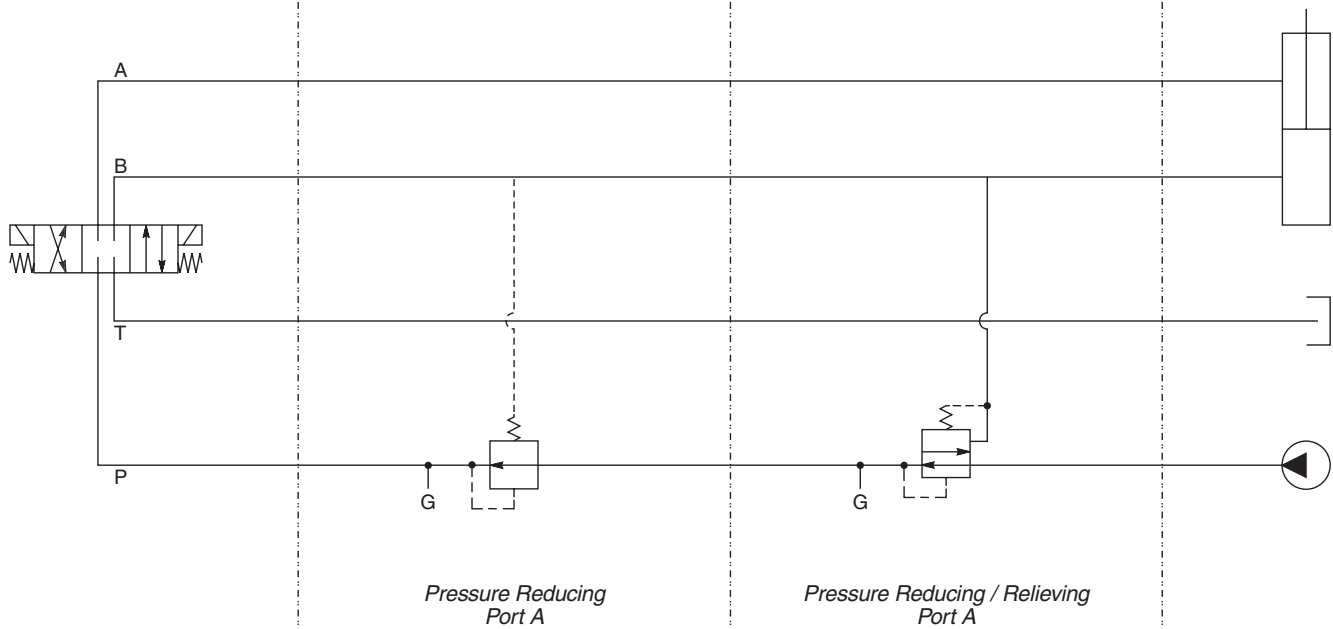

- CV** Check Valves
- SH** Shuttle Valves
- LM** Load/Motor Controls
- FC** Flow Controls
- PC** Pressure Controls
- LE** Logic Elements
- DC** Directional Controls
- MV** Manual Valves
- SV** Solenoid Valves
- PV** Proportional Valves
- CE** Coils & Electronics
- BC** Bodies & Cavities
- TD** Technical Data

Technical Information

For additional information see Technical Tips on pages BC1-BC6.

Dimensions

Millimeters (Inches)

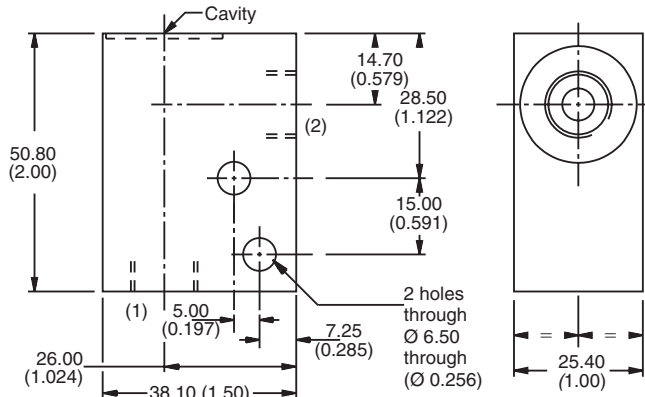
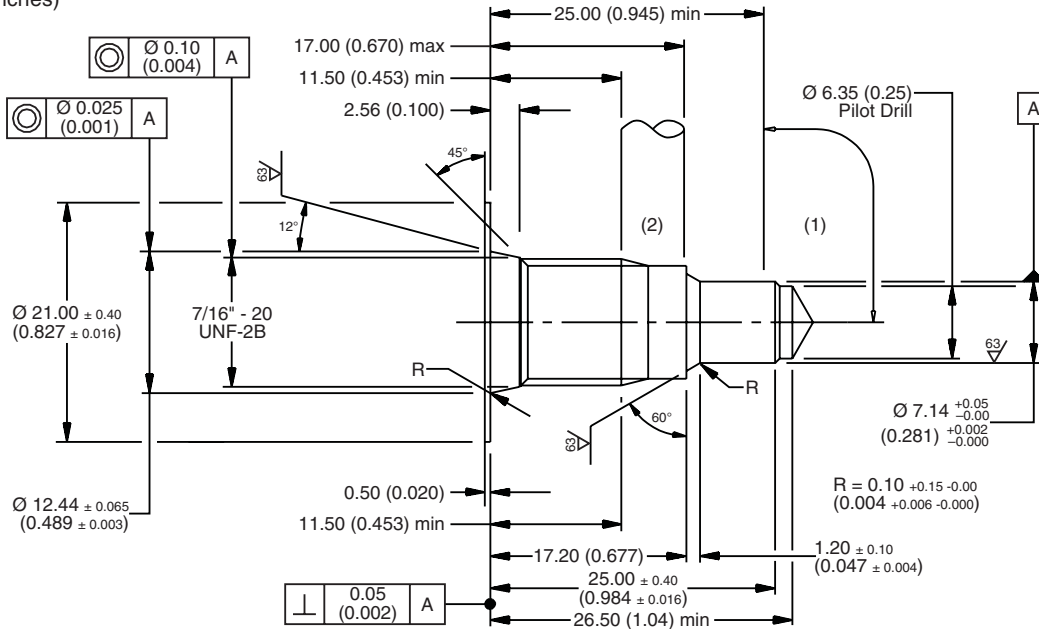

Ordering Information

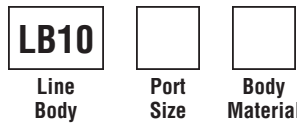

Code	Port Size
795	1/4 SAE
796	1/4 BSP

Code	Body Material
A	Aluminum
S	Steel

Cavity Tooling For CAV0W-2	
Pilot Drill Ø	6.35 (0.25)
Step Drill	8DS31369
Reamer (Alum)	8RM31082A
Reamer (Steel)	8RM31082S
Counterbore	—
Tap	8TP31221

- CV Check Valves
- SH Shuttle Valves
- LM Load/Motor Controls
- FC Flow Controls
- PC Pressure Controls
- LE Logic Elements
- DC Directional Controls
- MV Manual Valves
- SV Solenoid Valves
- PV Proportional Valves
- CE Coils & Electronics
- BC Bodies & Cavities
- TD Technical Data



Technical Information

For additional information see Technical Tips on pages BC1-BC6.

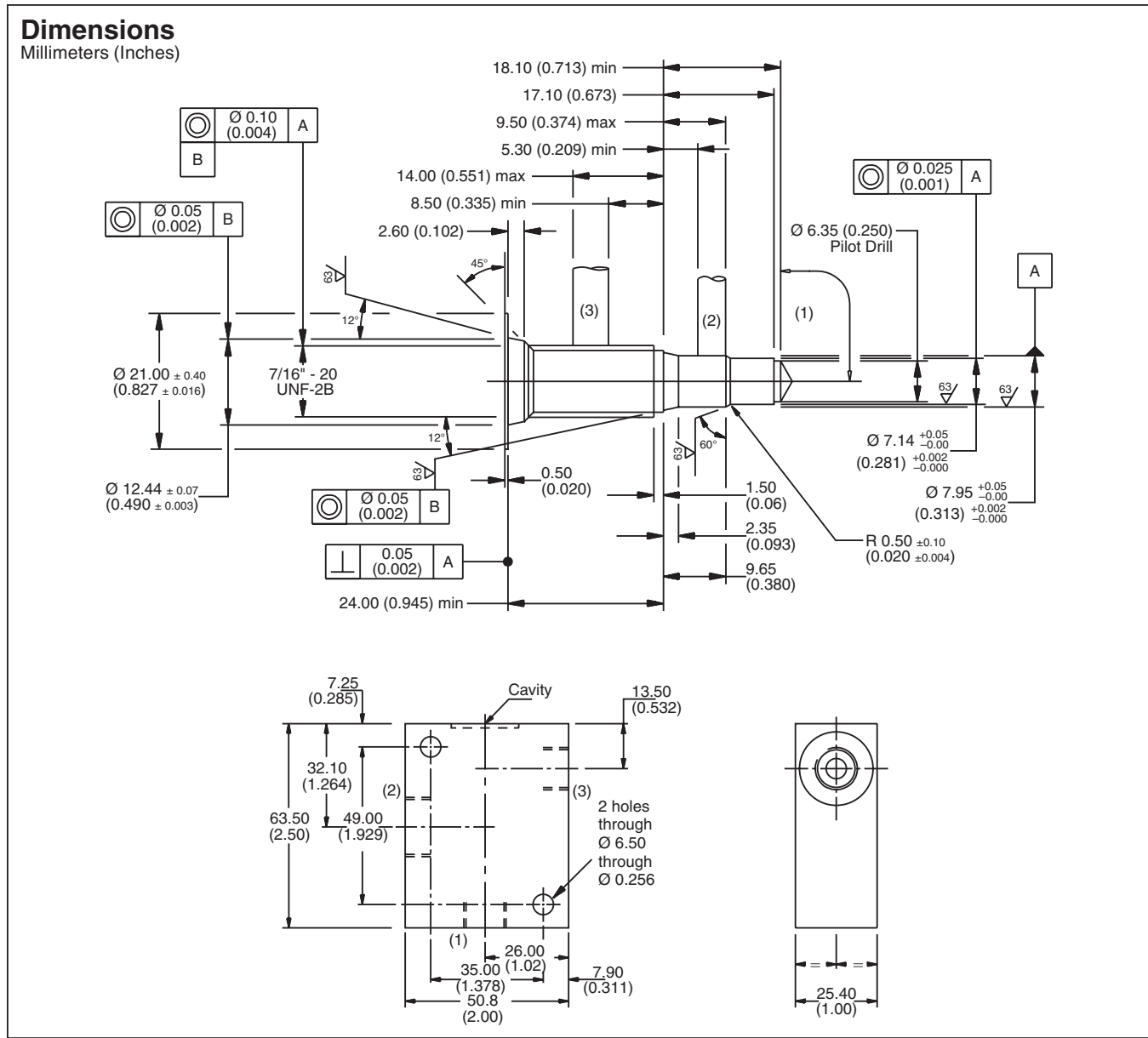

Ordering Information

LB10		
Line Body	Port Size	Body Material

Code	Port Size
815	1/4 SAE
816	1/4 BSP

Code	Body Material
A	Aluminum
S	Steel

Pilot Drill Ø	6.35 (0.25)
Step Drill	8DS31378
Reamer (Alum)	8RM31086A
Reamer (Steel)	8RM31086S
Counterbore	—
Tap	8TP31221

- CV Check Valves
- SH Shuttle Valves
- LM Load/Motor Controls
- FC Flow Controls
- PC Pressure Controls
- LE Logic Elements
- DC Directional Controls
- MV Manual Valves
- SV Solenoid Valves
- PV Proportional Valves
- CE Coils & Electronics
- BC Bodies & Cavities
- TD Technical Data

For additional information see Technical Tips on pages BC1-BC6.

Dimensions

Millimeters (Inches)

Ø31.75 (Ø1.25) This diameter is clearance for a socket to reach the valve and is only required if the locating shoulder is more than 23.82 (0.938) below the block surface.

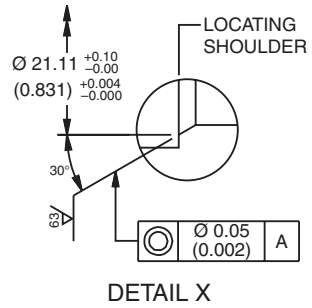
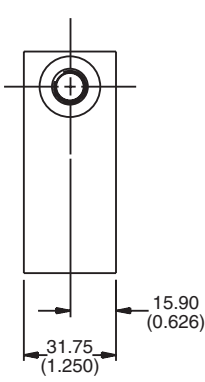
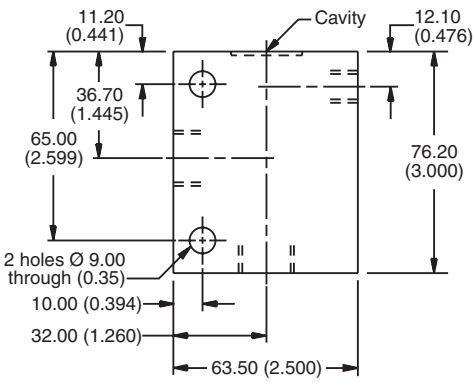
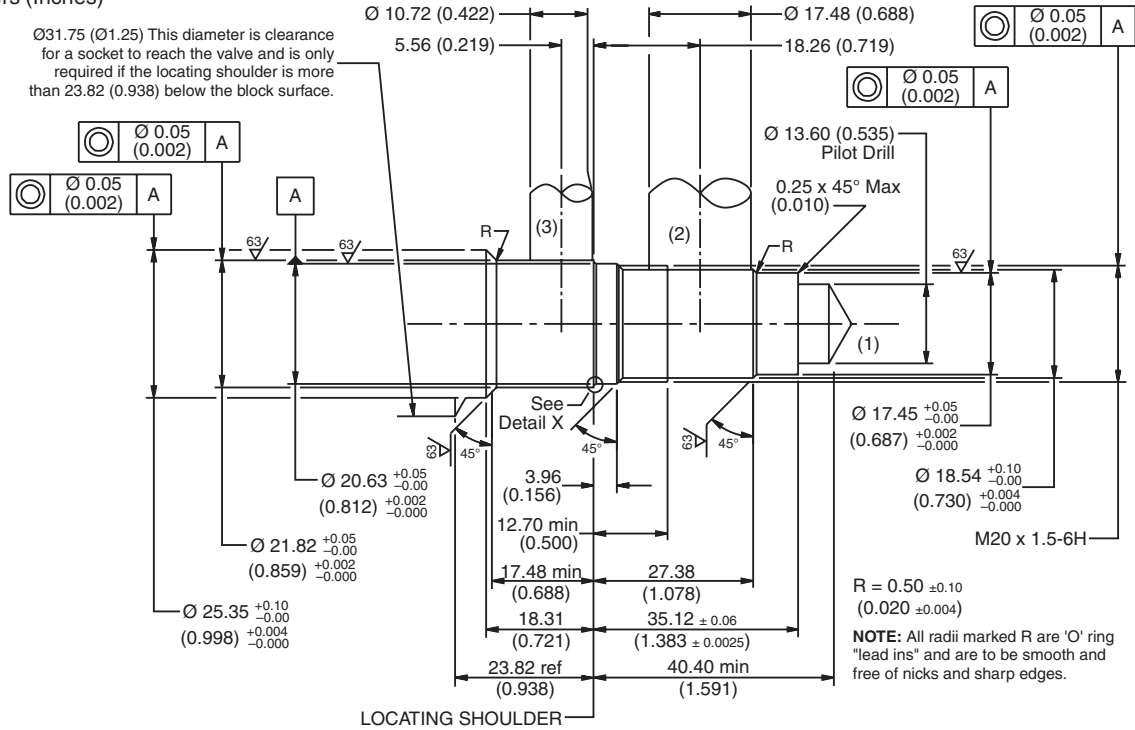

Ordering Information

LB10		
Line Body	Port Size	Body Material

Code	Port Size
825	1/2 SAE (Main) 1/4 SAE (Aux.)
826	1/2 BSP (Main) 1/4 BSP (Aux.)

Code	Body Material
A	Aluminum
S	Steel

Cavity Tooling For CAVT11A	
Pilot Drill Ø	13.60 (0.535)
Step Drill	8DS31387
Reamer (Alum)	8RM31095A
Reamer (Steel)	8RM31095S
Counterbore	—
Tap	8TP31209

- CV Check Valves
- SH Shuttle Valves
- LM Load/Motor Controls
- FC Flow Controls
- PC Pressure Controls
- LE Logic Elements
- DC Directional Controls
- MV Manual Valves
- SV Solenoid Valves
- PV Proportional Valves
- CE Coils & Electronics
- BC Bodies & Cavities
- TD Technical Data

For additional information see Technical Tips on pages BC1-BC6.

Dimensions

Millimeters (Inches)

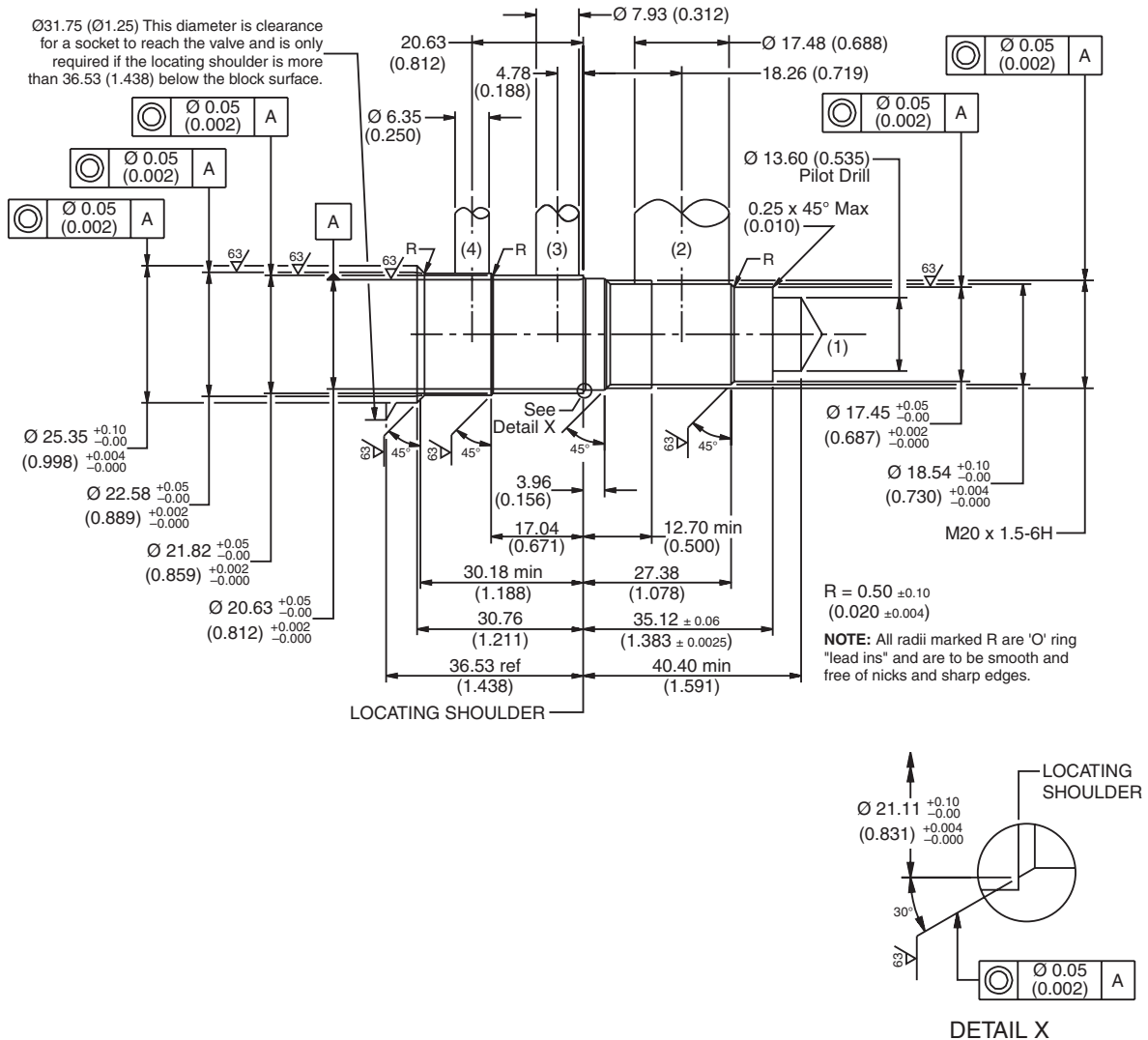

Ordering Information

LB10		
Line Body	Port Size	Body Material

Code	Port Size
830	1/2 SAE (Main) 3/8 + 1/4 SAE (Aux.)
831	1/2 BSP (Main) 3/8 + 1/4 BSP (Aux.)

Code	Body Material
A	Aluminum
S	Steel

Cavity Tooling For CAVT11A	
Pilot Drill Ø	13.60 (0.535)
Step Drill	8DS31388
Reamer (Alum)	8RM31096A
Reamer (Steel)	8RM31096S
Counterbore	—
Tap	8TP31209



- CV** Check Valves
- SH** Shuttle Valves
- LM** Load/Motor Controls
- FC** Flow Controls
- PC** Pressure Controls
- LE** Logic Elements
- DC** Directional Controls
- MV** Manual Valves
- SV** Solenoid Valves
- PV** Proportional Valves
- CE** Coils & Electronics
- BC** Bodies & Cavities
- TD** Technical Data

For additional information see Technical Tips on pages BC1-BC6.

Dimensions
 Millimeters (Inches)

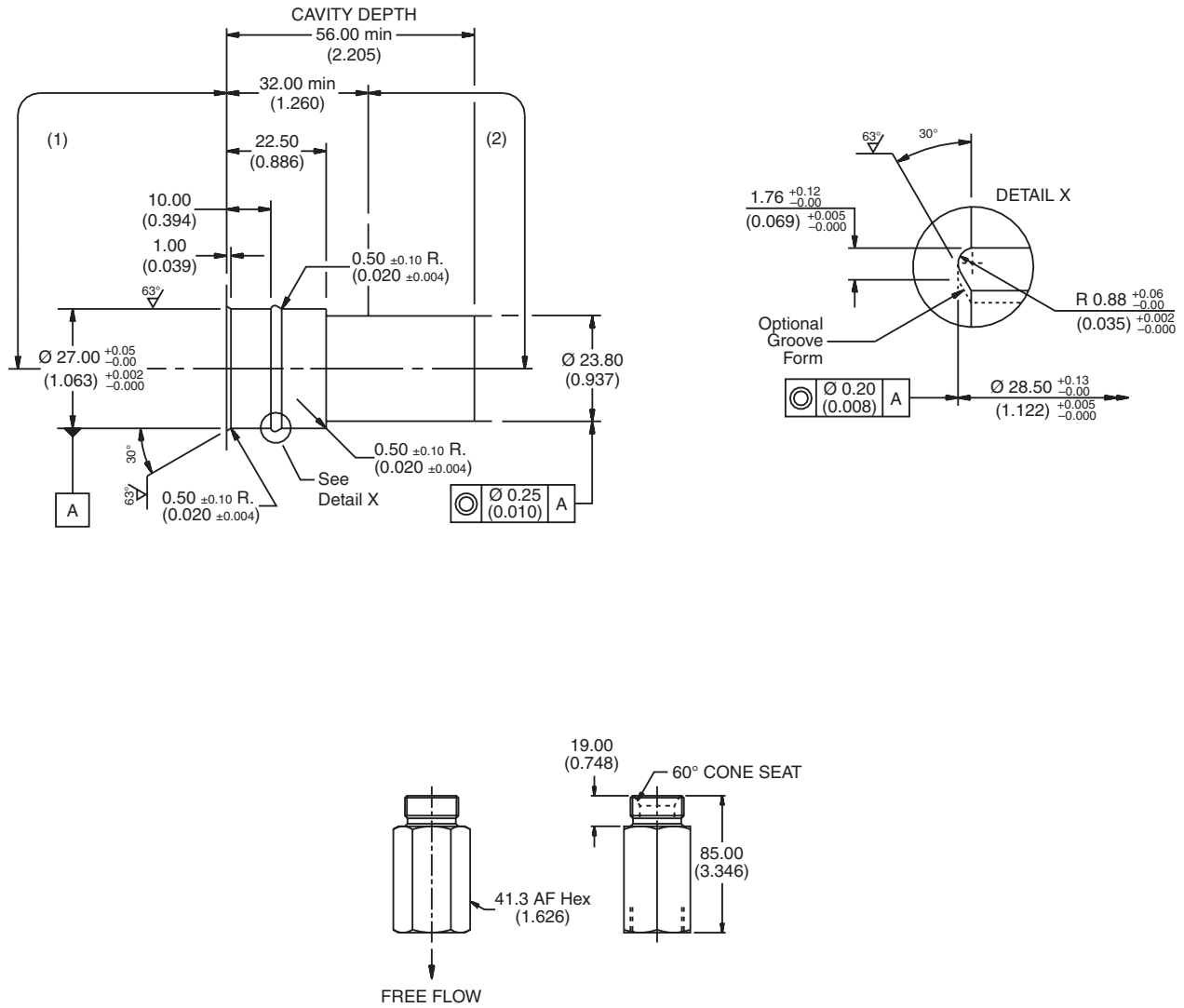

Ordering Information

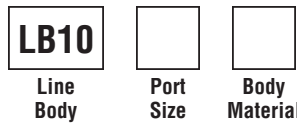

Code	Port Size
210	1 BSP
212	1 SAE

Code	Body Material
A	Aluminum
S	Steel

Cavity Tooling For 2C	
Pilot Drill Ø	—
Step Drill	—
Reamer (Alum)	—
Reamer (Steel)	—
Counterbore	—
Tap	—

- CV** Check Valves
- SH** Shuttle Valves
- LM** Load/Motor Controls
- FC** Flow Controls
- PC** Pressure Controls
- LE** Logic Elements
- DC** Directional Controls
- MV** Manual Valves
- SV** Solenoid Valves
- PV** Proportional Valves
- CE** Coils & Electronics
- BC** Bodies & Cavities
- TD** Technical Data

For additional information see Technical Tips on pages BC1-BC6.

Dimensions
 Millimeters (Inches)

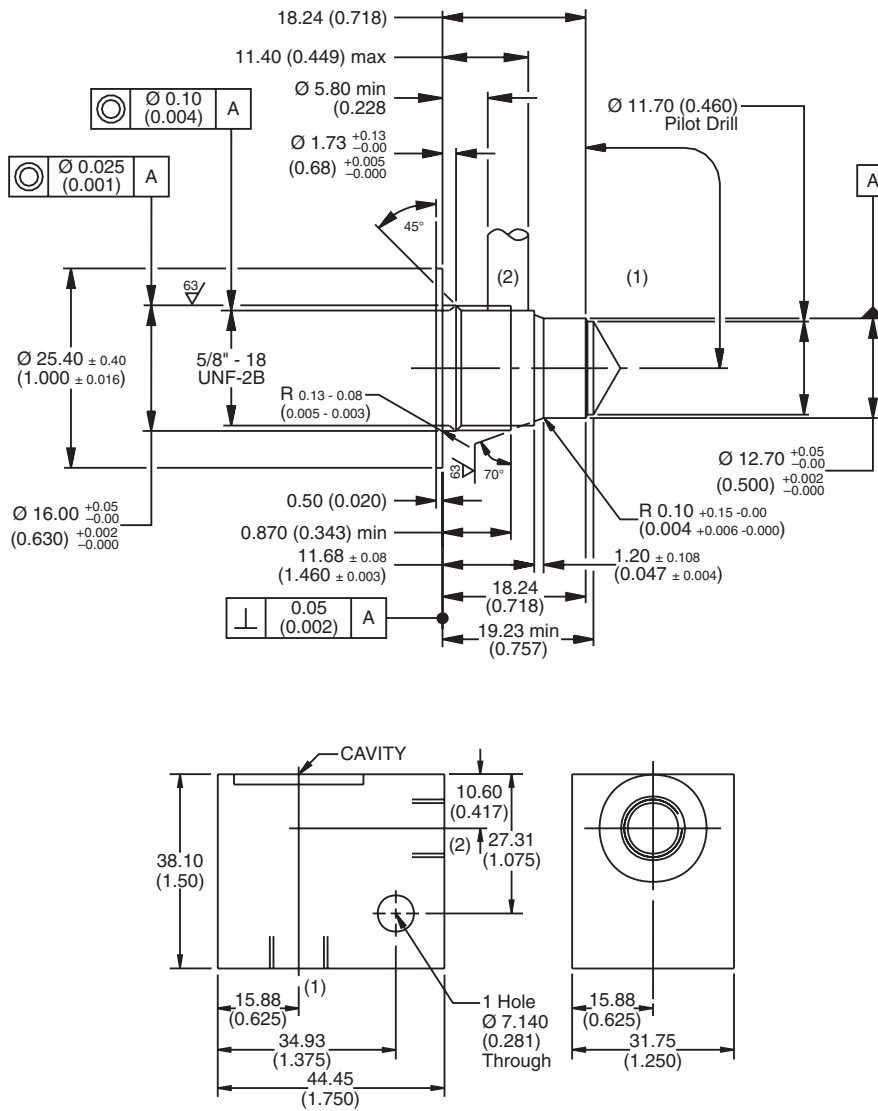

Ordering Information

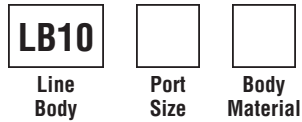

Code	Port Size
324	1/4 SAE
325	1/4 BSP

Code	Body Material
A	Aluminum
S	Steel

Cavity Tooling For 2G	
Pilot Drill Ø	11.70 (0.46)
Step Drill	8DS31384
Reamer (Alum)	8RM31092A
Reamer (Steel)	8RM31092S
Counterbore	—
Tap	8TP31223

- CV** Check Valves
- SH** Shuttle Valves
- LM** Load/Motor Controls
- FC** Flow Controls
- PC** Pressure Controls
- LE** Logic Elements
- DC** Directional Controls
- MV** Manual Valves
- SV** Solenoid Valves
- PV** Proportional Valves
- CE** Coils & Electronics
- BC** Bodies & Cavities
- TD** Technical Data

Technical Information

For additional information see Technical Tips on pages BC1-BC6.

Dimensions

Millimeters (Inches)

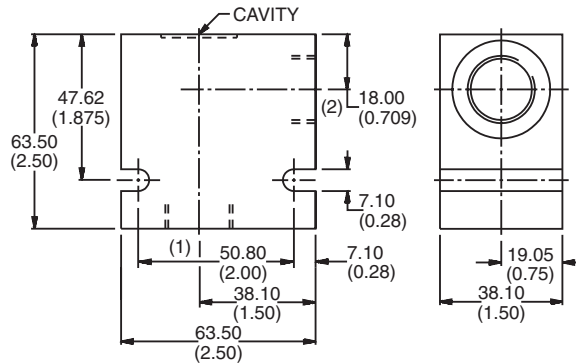
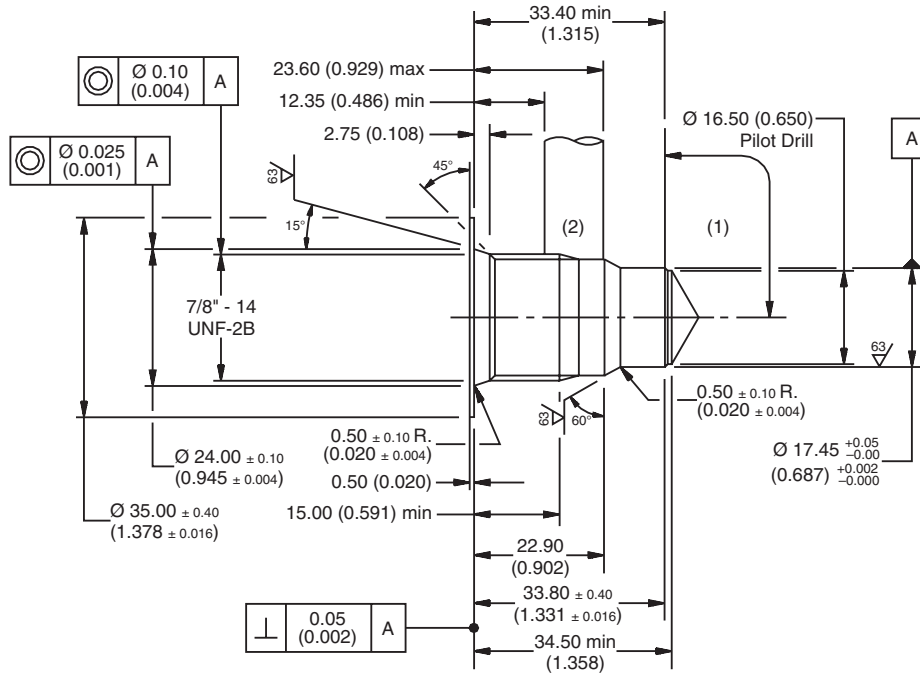

Ordering Information

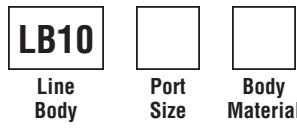

Code	Port Size
543	1/2 SAE
545	1/2 BSP

Code	Body Material
A	Aluminum
S	Steel

Cavity Tooling For 2R
Pilot Drill Ø
Step Drill
Reamer (Alum)
Reamer (Steel)
Counterbore
Tap

- CV Check Valves
- SH Shuttle Valves
- LM Load/Motor Controls
- FC Flow Controls
- PC Pressure Controls
- LE Logic Elements
- DC Directional Controls
- MV Manual Valves
- SV Solenoid Valves
- PV Proportional Valves
- CE Coils & Electronics
- BC Bodies & Cavities
- TD Technical Data

For additional information see Technical Tips on pages BC1-BC6.

Dimensions

Millimeters (Inches)

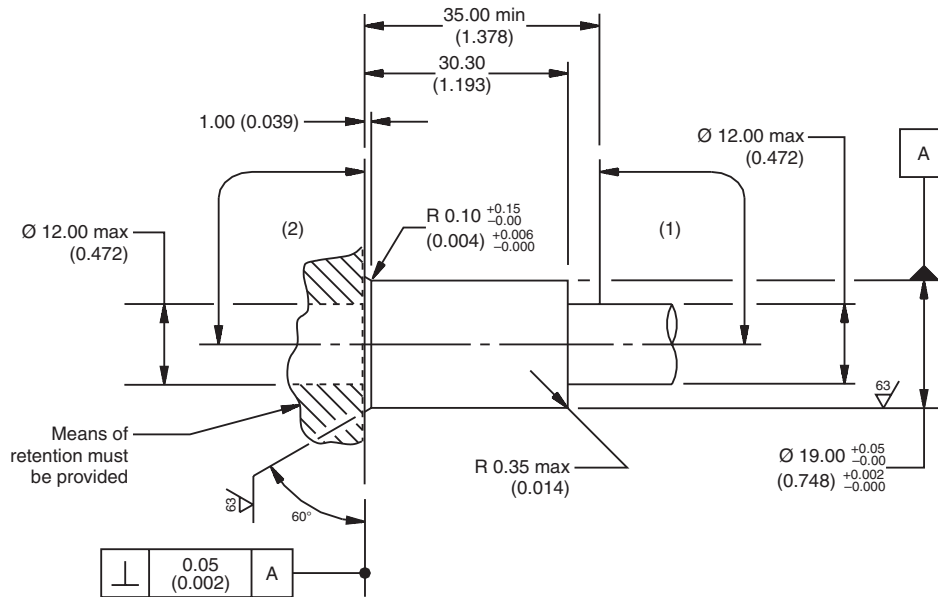

\perp	0.05 (0.002)	A
---------	-----------------	---

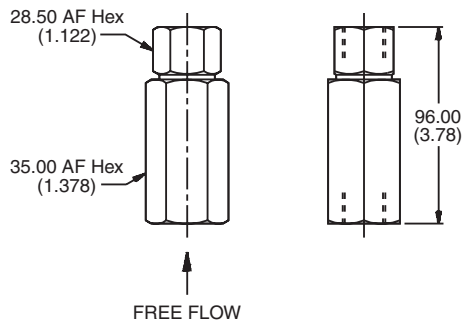

Ordering Information

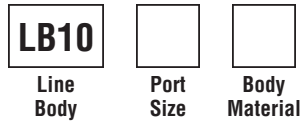

Code	Port Size
205	1 BSP
220	1 SAE

Code	Body Material
S	Steel

Cavity Tooling For 2U	
Pilot Drill Ø	—
Step Drill	—
Reamer (Alum)	—
Reamer (Steel)	—
Counterbore	—
Tap	—

- CV**
Check Valves
- SH**
Shuttle Valves
- LM**
Load/Motor Controls
- FC**
Flow Controls
- PC**
Pressure Controls
- LE**
Logic Elements
- DC**
Directional Controls
- MV**
Manual Valves
- SV**
Solenoid Valves
- PV**
Proportional Valves
- CE**
Coils & Electronics
- BC**
Bodies & Cavities
- TD**
Technical Data

For additional information see Technical Tips on pages BC1-BC6.

Dimensions
 Millimeters (Inches)

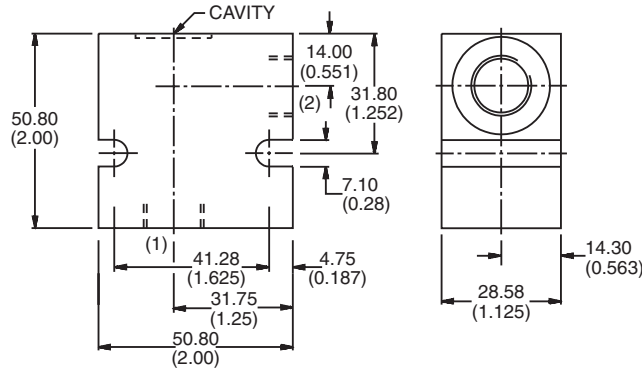
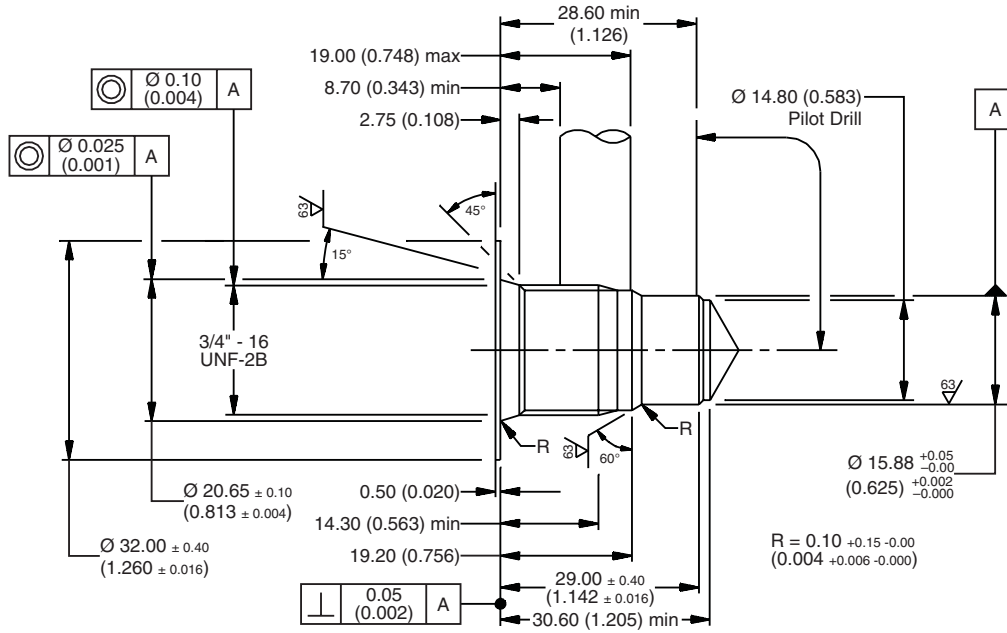

Ordering Information

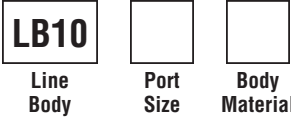

Code	Port Size
513	3/8 SAE
515	1/4 BSP

Code	Body Material
A	Aluminum
S	Steel

Cavity Tooling For 2X	
Pilot Drill Ø	14.80 (0.583)
Step Drill	8DS31344
Reamer (Alum)	8RM31057A
Reamer (Steel)	8RM31057S
Counterbore	—
Tap	8TP31202

NOTE:
 Use parker C09-2 cavity and body.

- CV** Check Valves
- SH** Shuttle Valves
- LM** Load/Motor Controls
- FC** Flow Controls
- PC** Pressure Controls
- LE** Logic Elements
- DC** Directional Controls
- MV** Manual Valves
- SV** Solenoid Valves
- PV** Proportional Valves
- CE** Coils & Electronics
- BC** Bodies & Cavities
- TD** Technical Data

For additional information see Technical Tips on pages BC1-BC6.

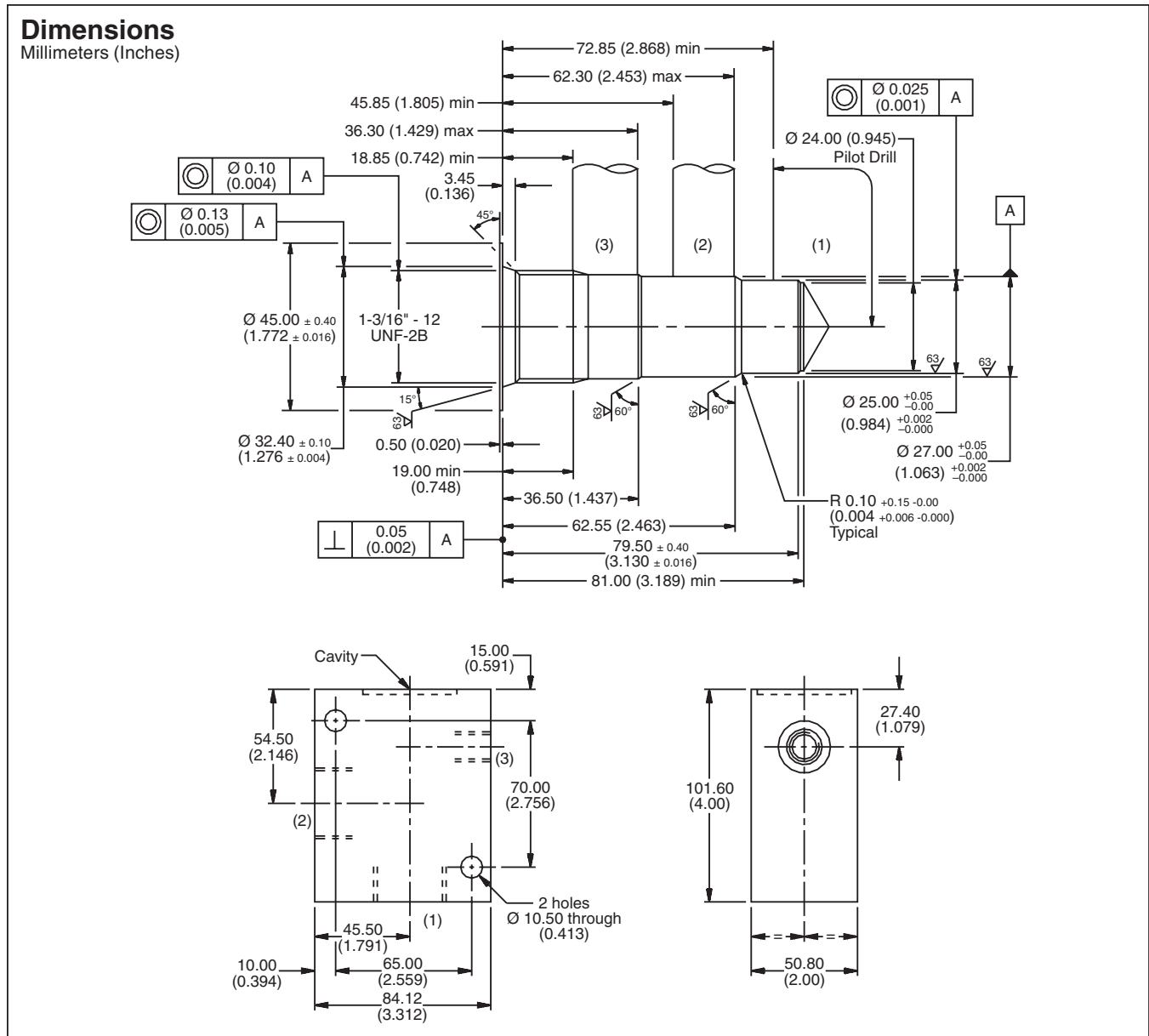

Ordering Information

LB10		
Line Body	Port Size	Body Material

Code	Port Size
007	3/4 BSP
066	1 SAE

Code	Body Material
A	Aluminum
S	Steel

Cavity Tooling For 3A	
Pilot Drill Ø	24.00 (0.94)
Step Drill	8DS31303
Reamer (Alum)	8RM31003A
Reamer (Steel)	8RM31003S
Counterbore	8CB31100
Tap	8TP31200

Technical Information

For additional information see Technical Tips on pages BC1-BC6.

Dimensions

Millimeters (Inches)

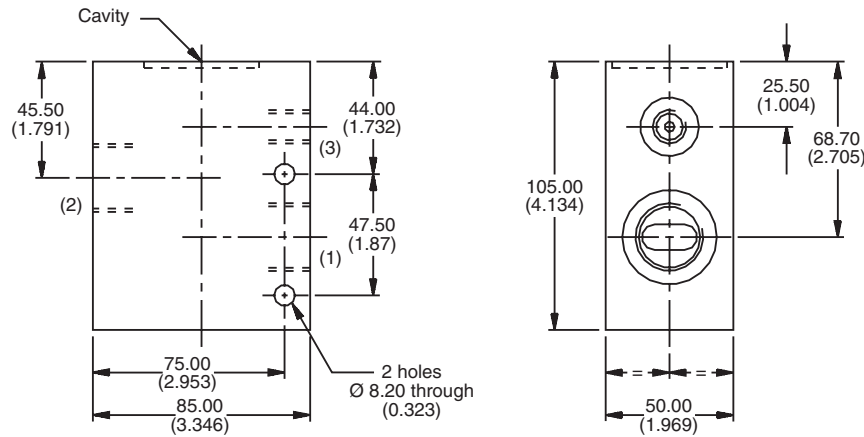
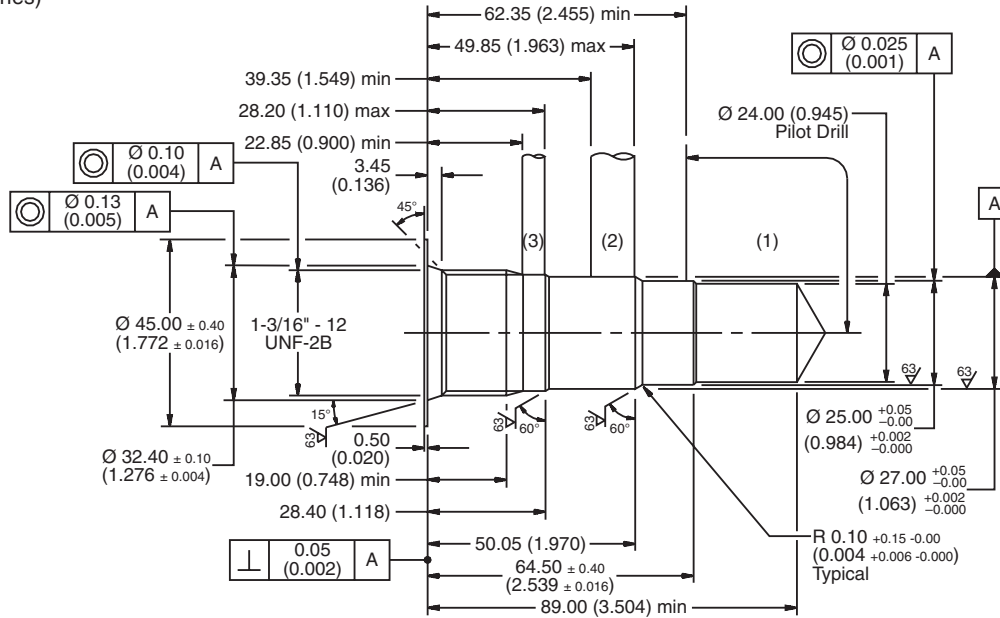

Ordering Information

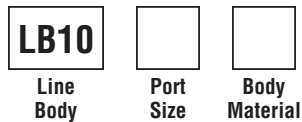

Code	Port Size
039	3/4 BSP (Main) 1/4 BSP (Aux.)
069	1 SAE (Main) 1/4 SAE (Aux.)
034	3/4 BSP Dual Cavity
234	3/4 SAE Dual Cavity

Code	Body Material
A	Aluminum
S	Steel

Cavity Tooling For 3C	
Pilot Drill Ø	24.00 (0.94)
Step Drill	8DS31305
Reamer (Alum)	8RM31005A
Reamer (Steel)	8RM31005S
Counterbore	8CB31100
Tap	8TP31200

- CV Check Valves
- SH Shuttle Valves
- LM Load/Motor Controls
- FC Flow Controls
- PC Pressure Controls
- LE Logic Elements
- DC Directional Controls
- MV Manual Valves
- SV Solenoid Valves
- PV Proportional Valves
- CE Coils & Electronics
- BC Bodies & Cavities
- TD Technical Data

For additional information see Technical Tips on pages BC1-BC6.

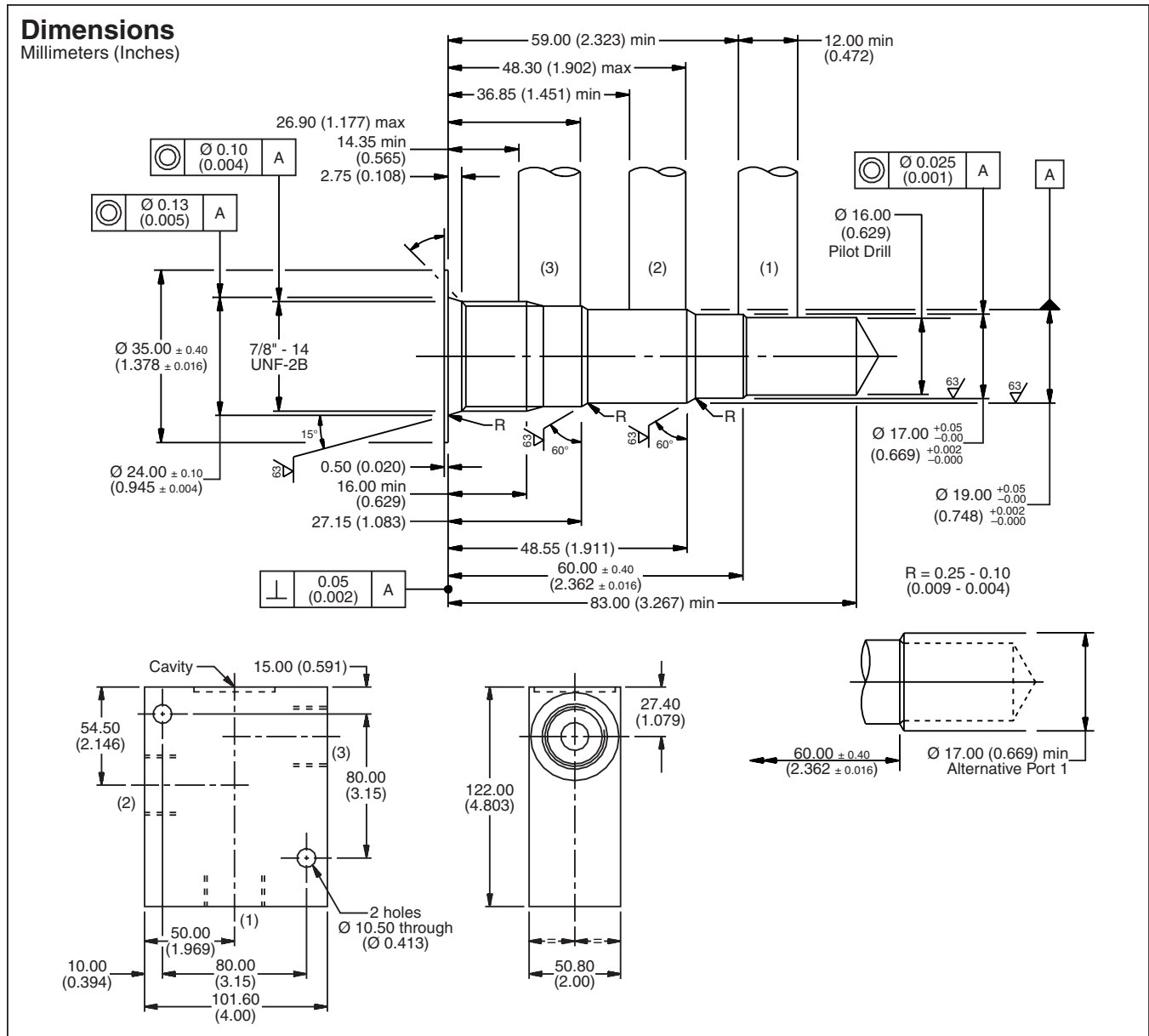

- CV** Check Valves
- SH** Shuttle Valves
- LM** Load/Motor Controls
- FC** Flow Controls
- PC** Pressure Controls
- LE** Logic Elements
- DC** Directional Controls
- MV** Manual Valves
- SV** Solenoid Valves
- PV** Proportional Valves
- CE** Coils & Electronics
- BC** Bodies & Cavities
- TD** Technical Data

For additional information see Technical Tips on pages BC1-BC6.

Dimensions
 Millimeters (Inches)

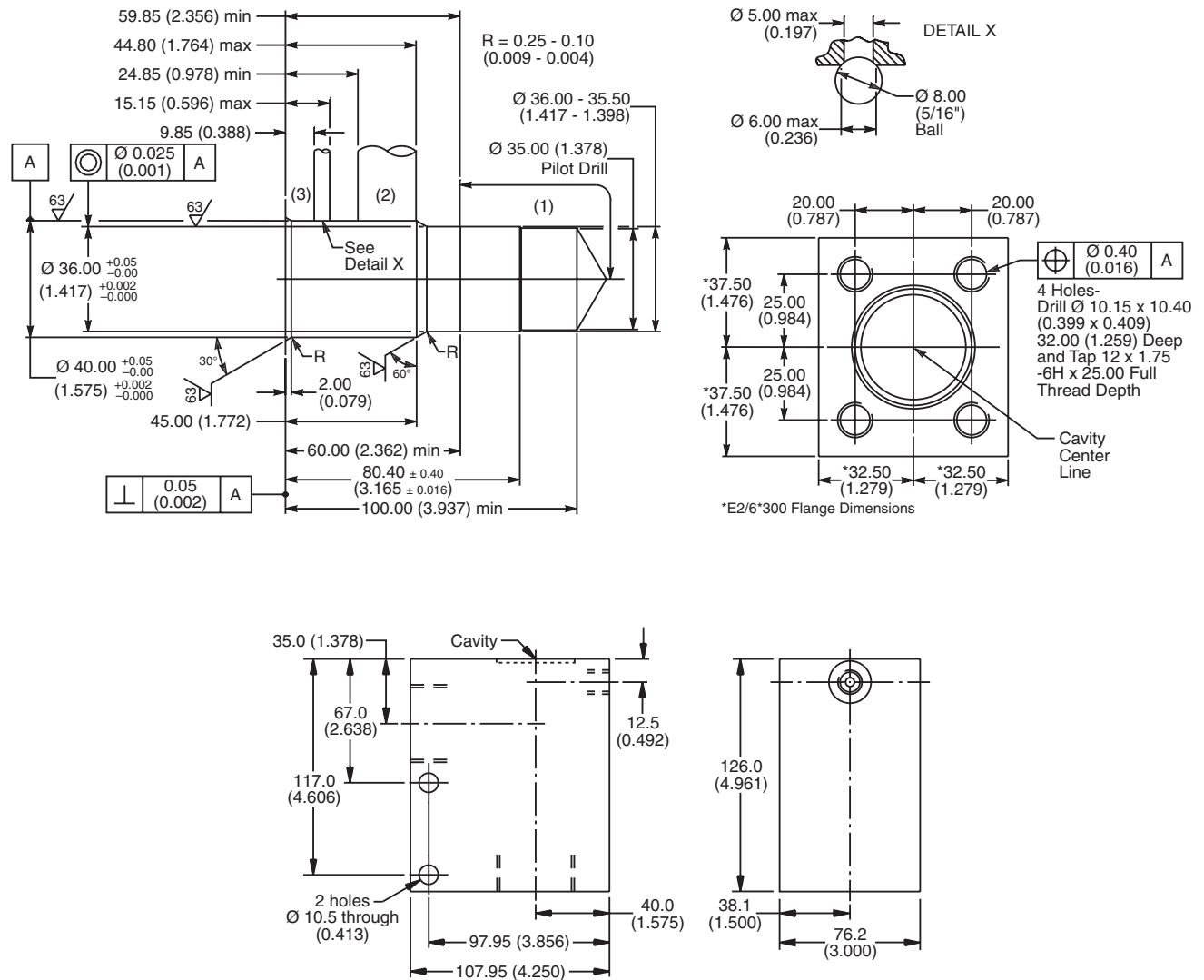

Ordering Information

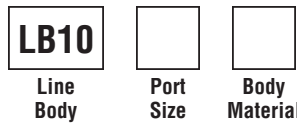

Code	Port Size
089	1-1/4 BSP (Main) 1/4 BSP (Aux)

Code	Body Material
A	Aluminum
S	Steel

Cavity Tooling For 3K	
Pilot Drill Ø	35.00 (1.38)
Step Drill	8DS31310
Reamer (Alum)	8RM31010A
Reamer (Steel)	8RM31010S
Counterbore	—
Tap	8TP31215

- CV Check Valves
- SH Shuttle Valves
- LM Load/Motor Controls
- FC Flow Controls
- PC Pressure Controls
- LE Logic Elements
- DC Directional Controls
- MV Manual Valves
- SV Solenoid Valves
- PV Proportional Valves
- CE Coils & Electronics
- BC Bodies & Cavities
- TD Technical Data

For additional information see Technical Tips on pages BC1-BC6.

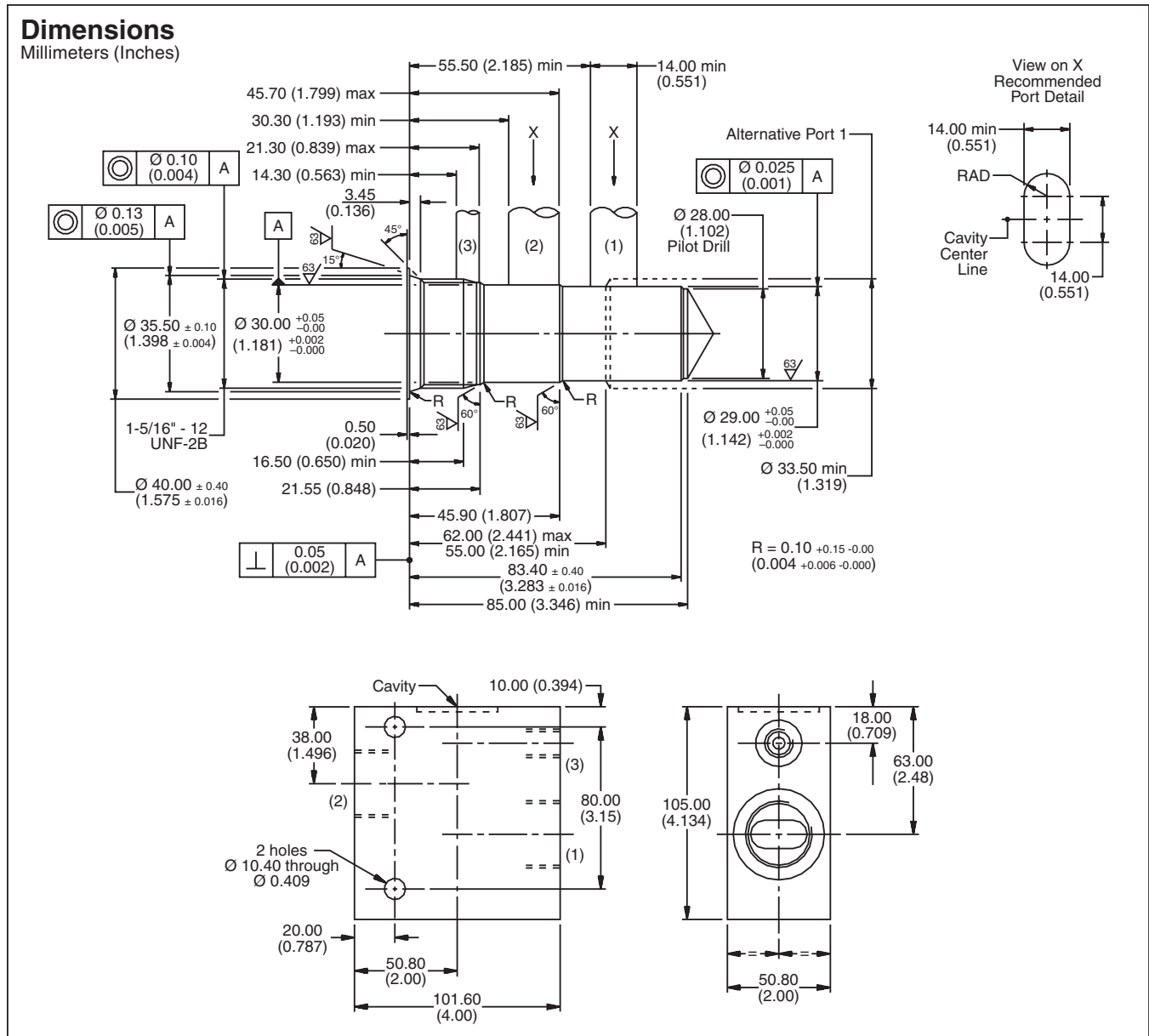

Ordering Information

LB10		
Line Body	Port Size	Body Material

Code	Port Size
076	1 BSP (Main) 1/4 BSP (Aux.)
078	1 SAE (Main) 1/4 SAE (Aux.)
104	1 BSP Dual Cavity
105	1 SAE Dual Cavity

Code	Body Material
A	Aluminum
S	Steel

Cavity Tooling For 3M	
Pilot Drill Ø	28.00 (1.10)
Step Drill	8DS31311
Reamer (Alum)	8RM31011A
Reamer (Steel)	8RM31011S
Counterbore	8CB31103
Tap	8TP31203



- CV**
Check Valves
- SH**
Shuttle Valves
- LM**
Load/Motor Controls
- FC**
Flow Controls
- PC**
Pressure Controls
- LE**
Logic Elements
- DC**
Directional Controls
- MV**
Manual Valves
- SV**
Solenoid Valves
- PV**
Proportional Valves
- CE**
Coils & Electronics
- BC**
Bodies & Cavities
- TD**
Technical Data

Technical Information

For additional information see Technical Tips on pages BC1-BC6.

Dimensions

Millimeters (Inches)

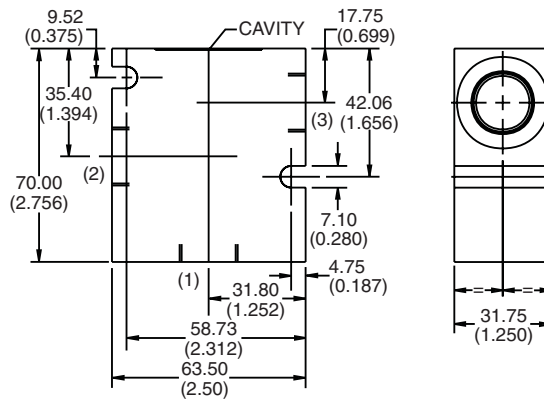
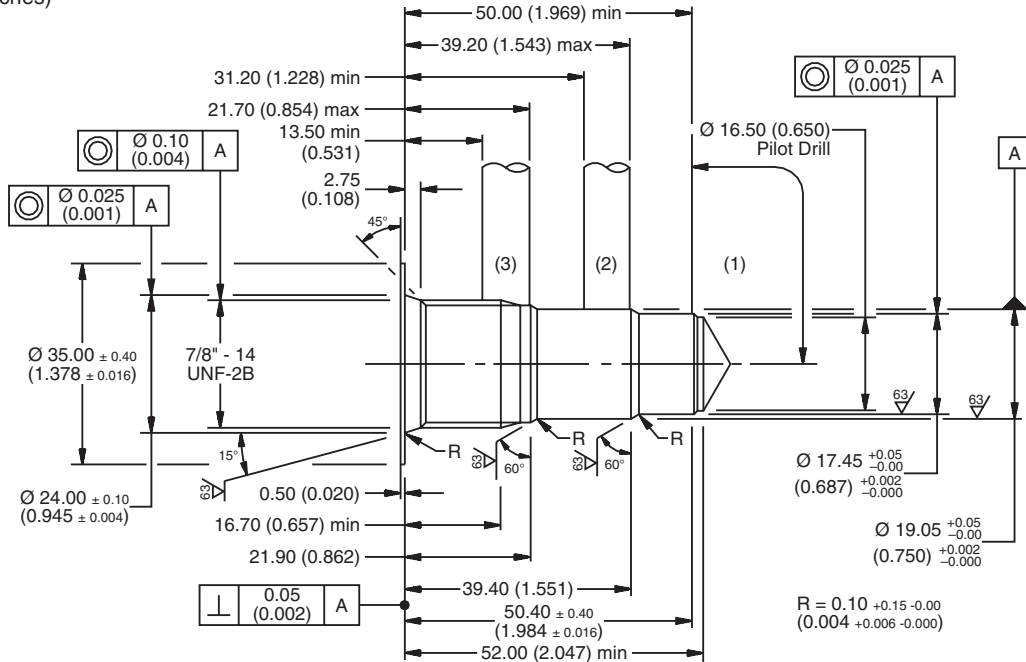

Ordering Information

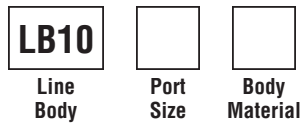

Code	Port Size
553	1/2 SAE
554	3/8 BSP

Code	Body Material
A	Aluminum
S	Steel

Cavity Tooling For 3X	
Pilot Drill Ø	16.50 (0.650)
Step Drill	8DS31343
Reamer (Alum)	8RM31062A
Reamer (Steel)	8RM31062S
Counterbore	—
Tap	8TP31201

- CV Check Valves
- SH Shuttle Valves
- LM Load/Motor Controls
- FC Flow Controls
- PC Pressure Controls
- LE Logic Elements
- DC Directional Controls
- MV Manual Valves
- SV Solenoid Valves
- PV Proportional Valves
- CE Coils & Electronics
- BC Bodies & Cavities
- TD Technical Data

For additional information see Technical Tips on pages BC1-BC6.

Dimensions

Millimeters (Inches)

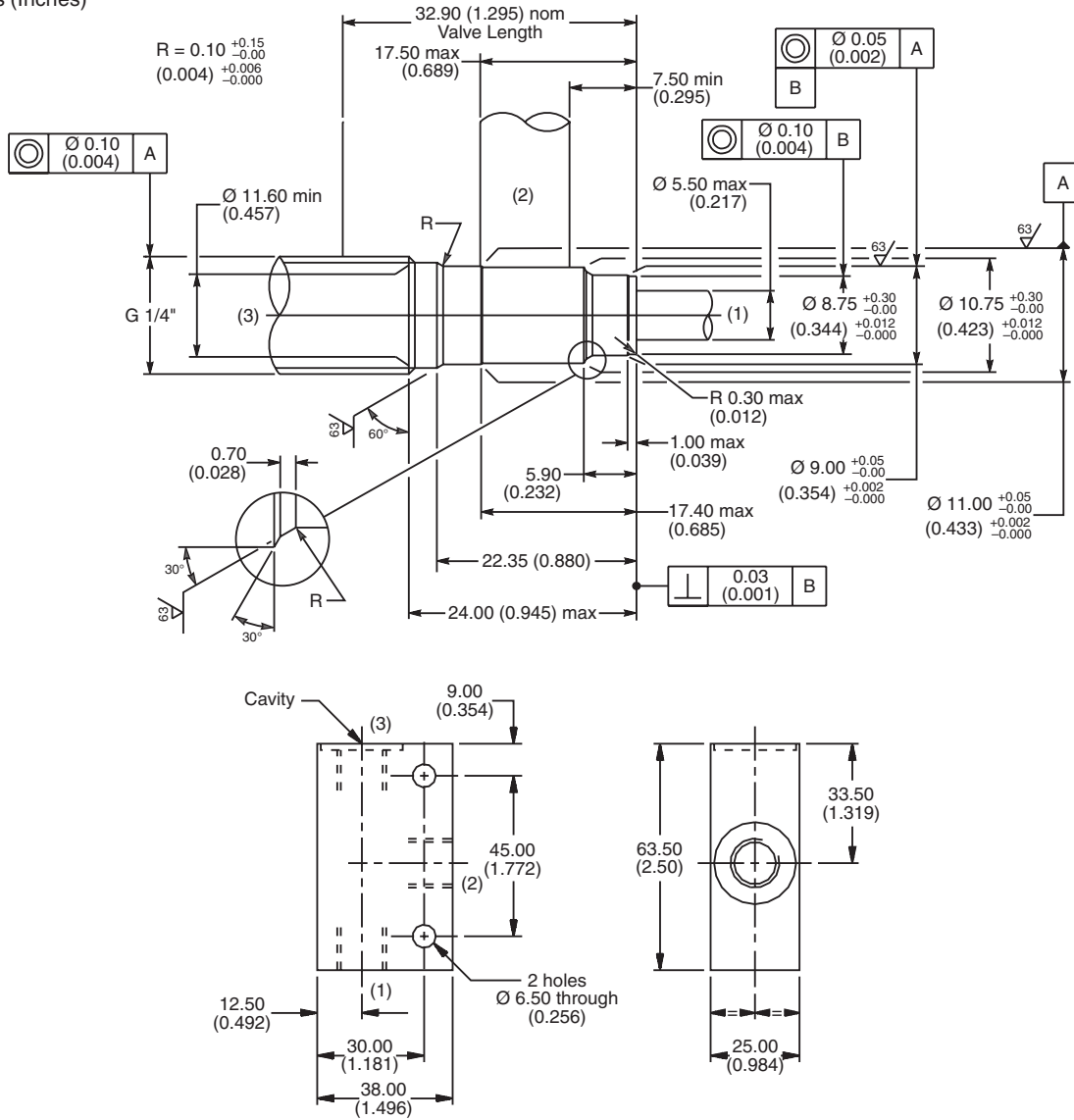

Ordering Information

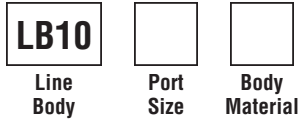

Code	Port Size
313	1/4 BSP
320	1/4 SAE

Code	Body Material
A	Aluminum
S	Steel

Cavity Tooling For 3Z	
Pilot Drill Ø	8.50 (0.335)
Step Drill	8DS31355
Reamer (Alum)	8RM31055A
Reamer (Steel)	8RM31055S
Counterbore	—
Tap	8TP31219

- CV**
Check Valves
- SH**
Shuttle Valves
- LM**
Load/Motor Controls
- FC**
Flow Controls
- PC**
Pressure Controls
- LE**
Logic Elements
- DC**
Directional Controls
- MV**
Manual Valves
- SV**
Solenoid Valves
- PV**
Proportional Valves
- CE**
Coils & Electronics
- BC**
Bodies & Cavities
- TD**
Technical Data

For additional information see Technical Tips on pages BC1-BC6.

Dimensions

Millimeters (Inches)

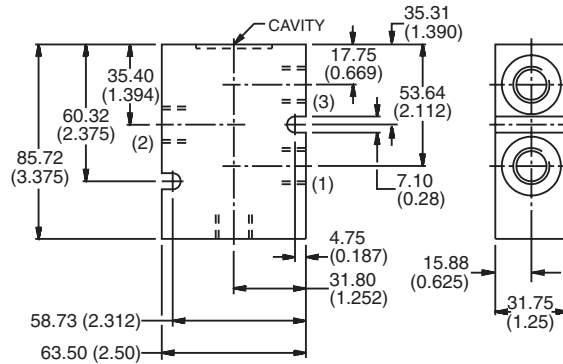
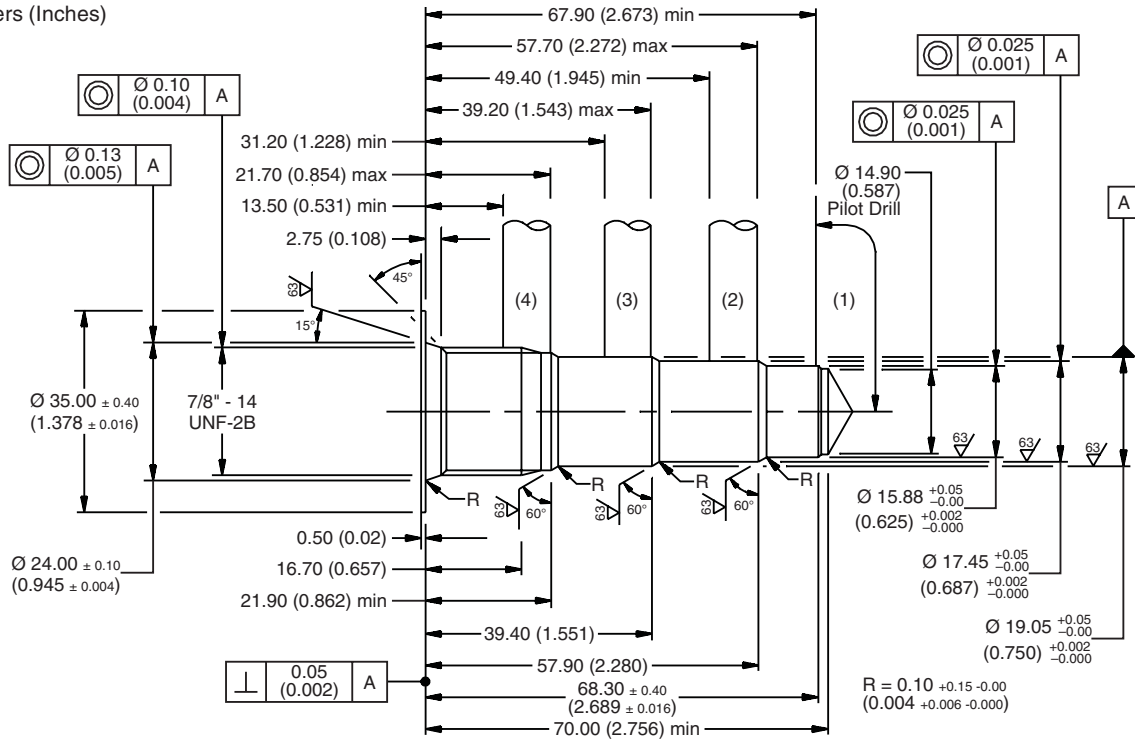

Ordering Information

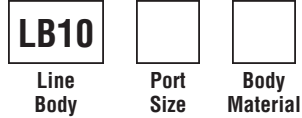

Code	Port Size
562	1/2 SAE
563	3/8 BSP

Code	Body Material
A	Aluminum
S	Steel

Cavity Tooling For 4C	
Pilot Drill Ø	14.90 (0.587)
Step Drill	8DS31346
Reamer (Alum)	8RM31063A
Reamer (Steel)	8RM31063S
Counterbore	—
Tap	8TP31201

- CV Check Valves
- SH Shuttle Valves
- LM Load/Motor Controls
- FC Flow Controls
- PC Pressure Controls
- LE Logic Elements
- DC Directional Controls
- MV Manual Valves
- SV Solenoid Valves
- PV Proportional Valves
- CE Coils & Electronics
- BC Bodies & Cavities
- TD Technical Data

For additional information see Technical Tips on pages BC1-BC6.

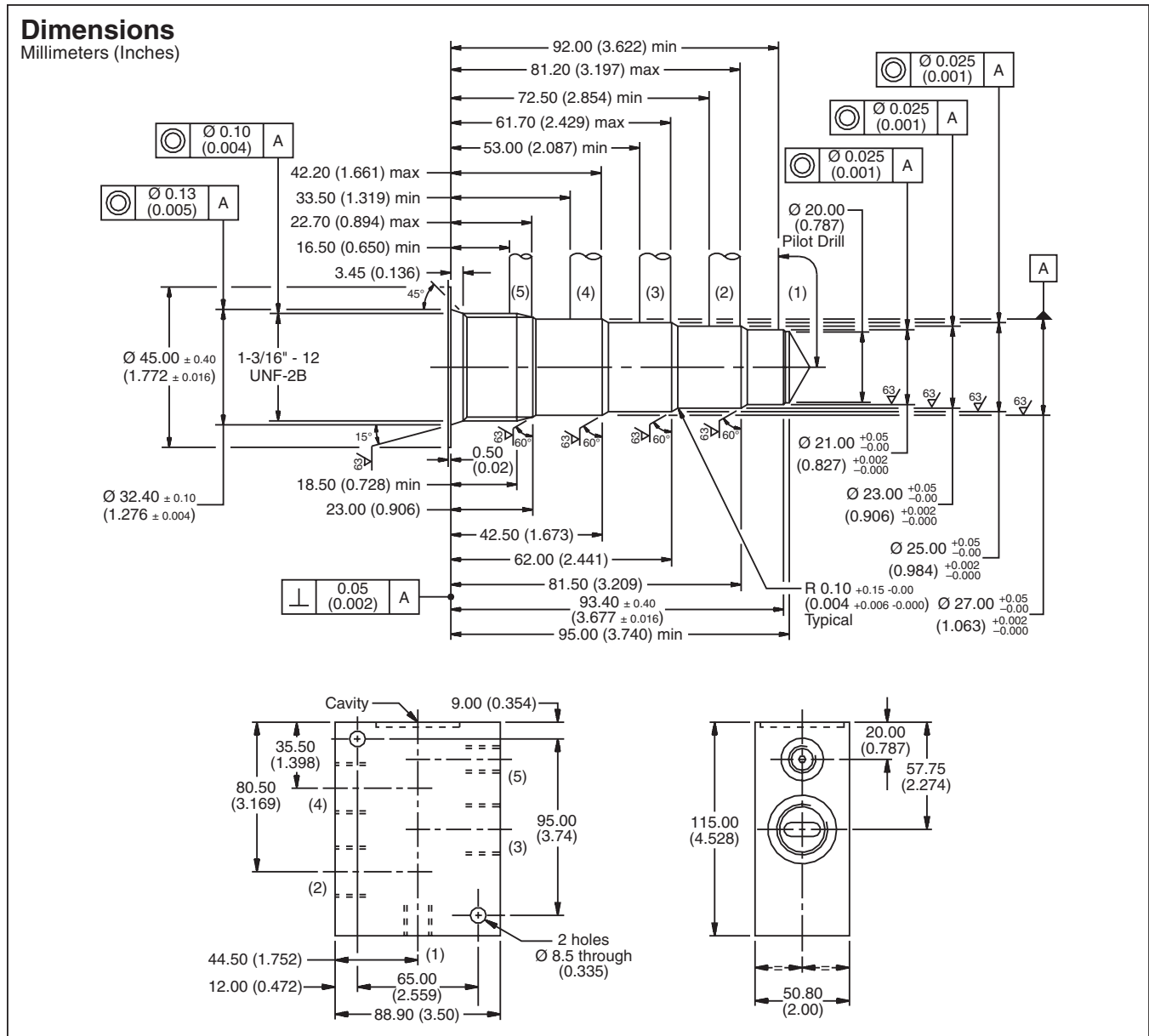

Ordering Information

LB10		
Line Body	Port Size	Body Material

Code	Port Size
314	3/4 BSP (Main) 1/4 BSP (Aux.)
321	3/4 SAE (Main) 1/4 SAE (Aux.)

Code	Body Material
A	Aluminum
S	Steel

Cavity Tooling For 5A	
Pilot Drill Ø	20.00 (0.78)
Step Drill	8DS31353
Reamer (Alum)	8RM31053A
Reamer (Steel)	8RM31053S
Counterbore	8CB31100
Tap	8TP31200

- CV** Check Valves
- SH** Shuttle Valves
- LM** Load/Motor Controls
- FC** Flow Controls
- PC** Pressure Controls
- LE** Logic Elements
- DC** Directional Controls
- MV** Manual Valves
- SV** Solenoid Valves
- PV** Proportional Valves
- CE** Coils & Electronics
- BC** Bodies & Cavities
- TD** Technical Data

For additional information see Technical Tips on pages BC1-BC6.

Dimensions

Millimeters (Inches)

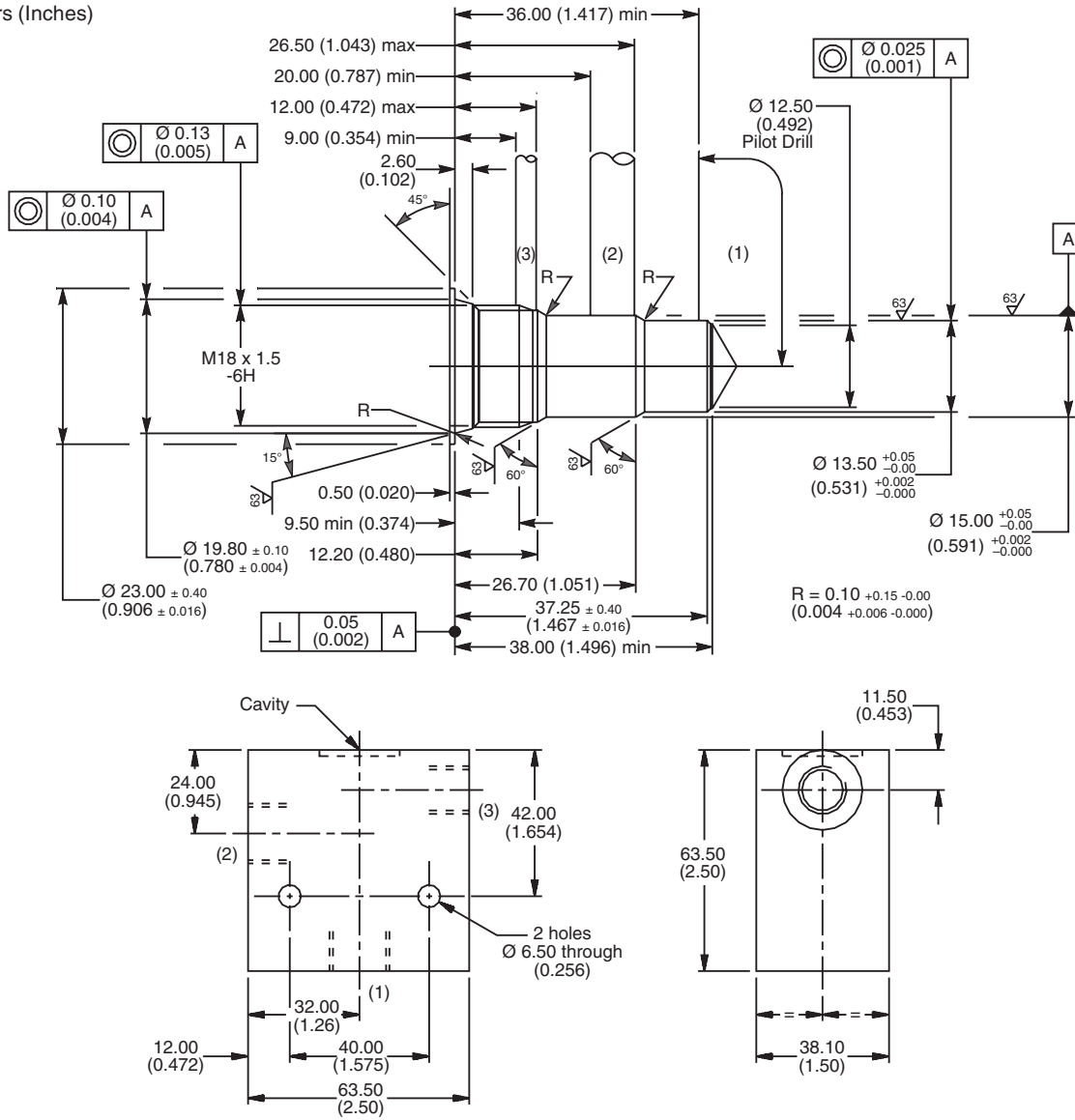

Ordering Information

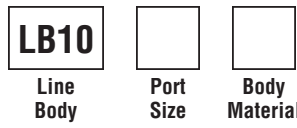

Code	Port Size
310	3/8 BSP (Main) 1/4 BSP (Aux.)
318	3/8 SAE (Main) 1/4 SAE (Aux.)
312	3/8 BSP Dual Cavity

Code	Body Material
A	Aluminum
S	Steel

Cavity Tooling For 53-1	
Pilot Drill Ø	12.50 (0.49)
Step Drill	8DS31349
Reamer (Alum)	8RM31081A
Reamer (Steel)	8RM31081S
Counterbore	—
Tap	8TP31207

CV Check Valves
SH Shuttle Valves
LM Load/Motor Controls
FC Flow Controls
PC Pressure Controls
LE Logic Elements
DC Directional Controls
MV Manual Valves
SV Solenoid Valves
PV Proportional Valves
CE Coils & Electronics
BC Bodies & Cavities
TD Technical Data

For additional information see Technical Tips on pages BC1-BC6.

Dimensions

Millimeters (Inches)

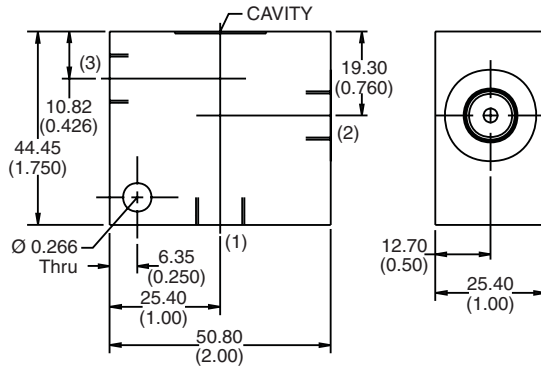
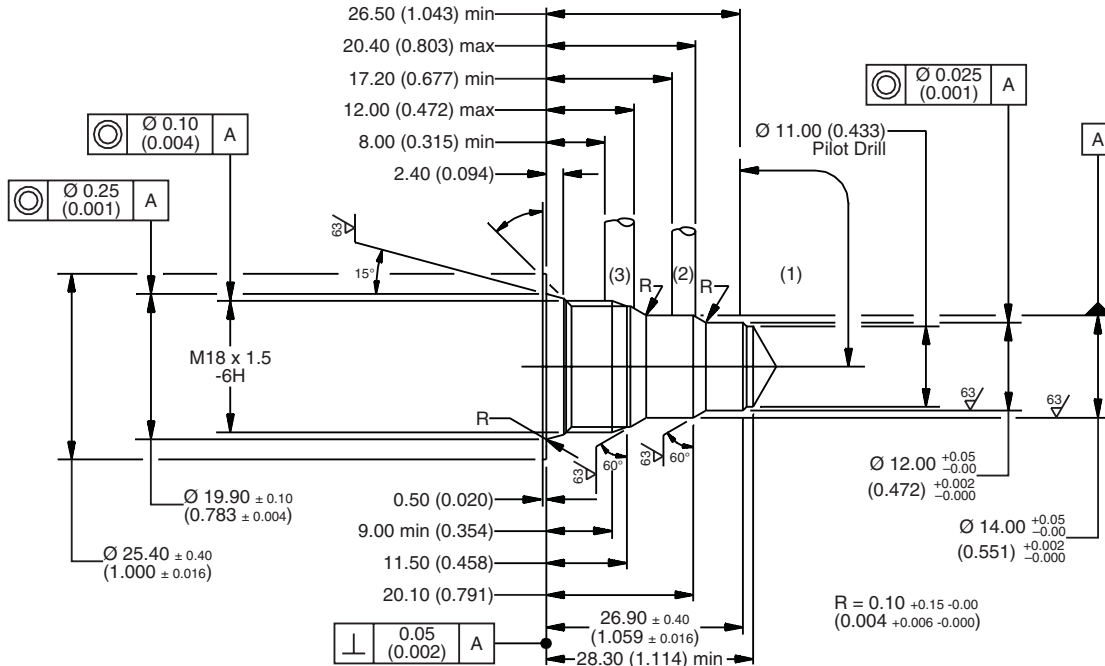

Ordering Information

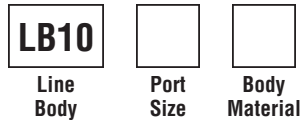

Code	Port Size
591	1/4 SAE

Code	Body Material
A	Aluminum
S	Steel

Cavity Tooling For 54-1	
Pilot Drill Ø	11.00 (0.433)
Step Drill	8DS31379
Reamer (Alum)	8RM31087A
Reamer (Steel)	8RM31087S
Counterbore	—
Tap	8TP31207

- CV**
Check Valves
- SH**
Shuttle Valves
- LM**
Load/Motor Controls
- FC**
Flow Controls
- PC**
Pressure Controls
- LE**
Logic Elements
- DC**
Directional Controls
- MV**
Manual Valves
- SV**
Solenoid Valves
- PV**
Proportional Valves
- CE**
Coils & Electronics
- BC**
Bodies & Cavities
- TD**
Technical Data

Technical Information

For additional information see Technical Tips on pages BC1-BC6.

Dimensions

Millimeters (Inches)

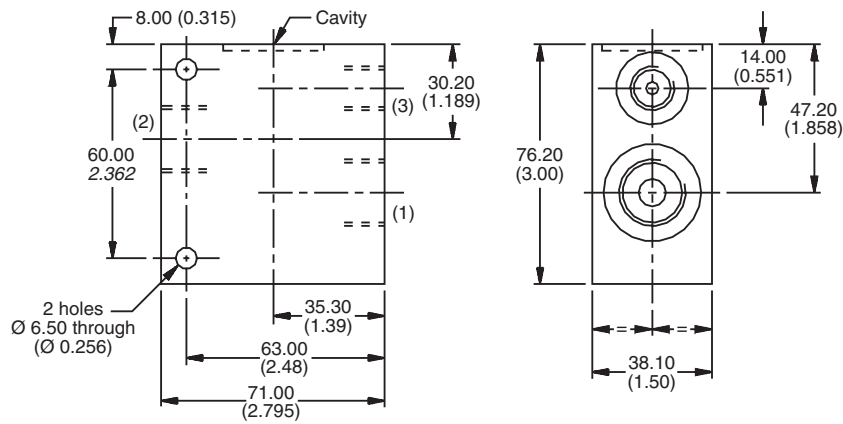
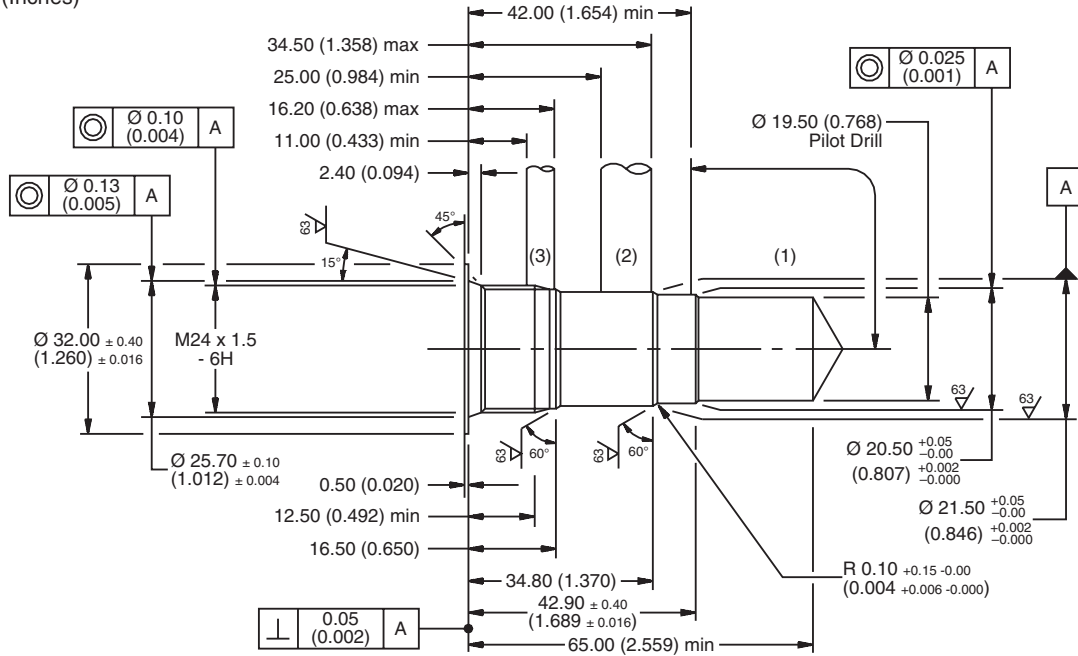

Ordering Information

LB10

Line Body Port Size Body Material

Code	Port Size
251	1/2 BSP (Main) 1/4 BSP (Aux.)
253	1/2 SAE (Main) 1/4 SAE (Aux.)

Code	Body Material
A	Aluminum
S	Steel

Cavity Tooling For 68-1	
Pilot Drill Ø	19.50 (0.77)
Step Drill	8DS31341
Reamer (Alum)	8RM31041A
Reamer (Steel)	8RM31041S
Counterbore	8CB31116
Tap	8TP31216

- CV Check Valves
- SH Shuttle Valves
- LM Load/Motor Controls
- FC Flow Controls
- PC Pressure Controls
- LE Logic Elements
- DC Directional Controls
- MV Manual Valves
- SV Solenoid Valves
- PV Proportional Valves
- CE Coils & Electronics
- BC Bodies & Cavities
- TD Technical Data

For additional information see Technical Tips on pages BC1-BC6.

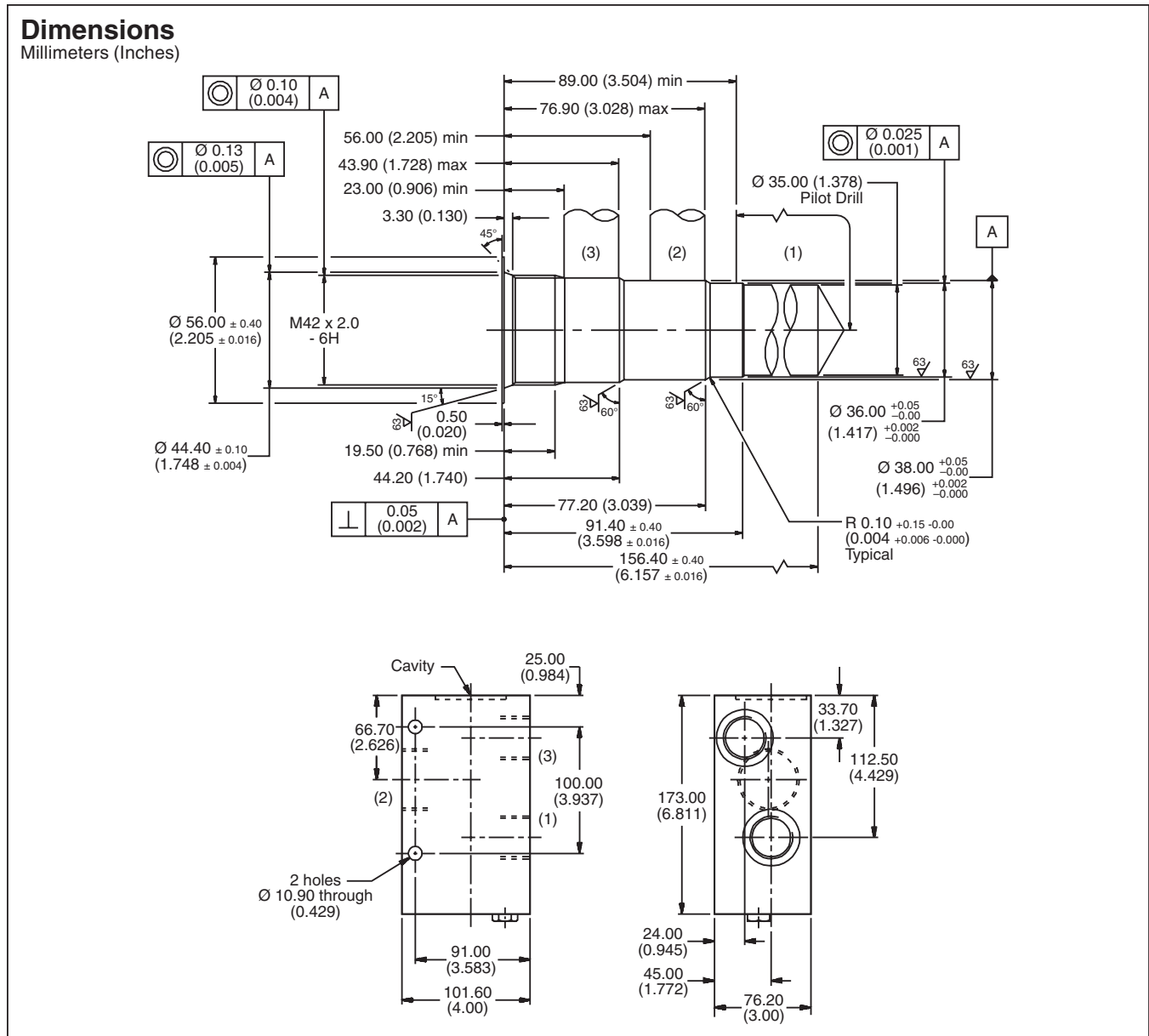

Ordering Information

LB10		
Line Body	Port Size	Body Material

Code	Port Size
156	2 x 1 BSP (Main) 1 x 1-1/2 BSP (Aux.)
157	2 x 1 SAE (Main) 1 x 1-1/2 SAE (Aux.)

Code	Body Material
A	Aluminum
S	Steel

Cavity Tooling For 91-1	
Pilot Drill Ø	35.00 (1.378)
Step Drill	8DS31332
Reamer (Alum)	8RM31032A
Reamer (Steel)	8RM31032S
Counterbore	8CB31118
Tap	8TP31213

- CV** Check Valves
- SH** Shuttle Valves
- LM** Load/Motor Controls
- FC** Flow Controls
- PC** Pressure Controls
- LE** Logic Elements
- DC** Directional Controls
- MV** Manual Valves
- SV** Solenoid Valves
- PV** Proportional Valves
- CE** Coils & Electronics
- BC** Bodies & Cavities
- TD** Technical Data

For additional information see Technical Tips on pages BC1-BC6.

Dimensions

Millimeters (Inches)

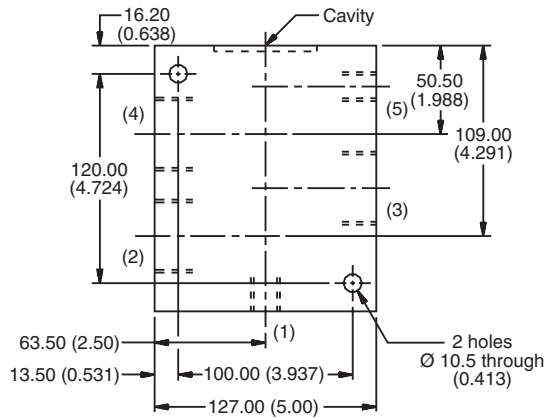
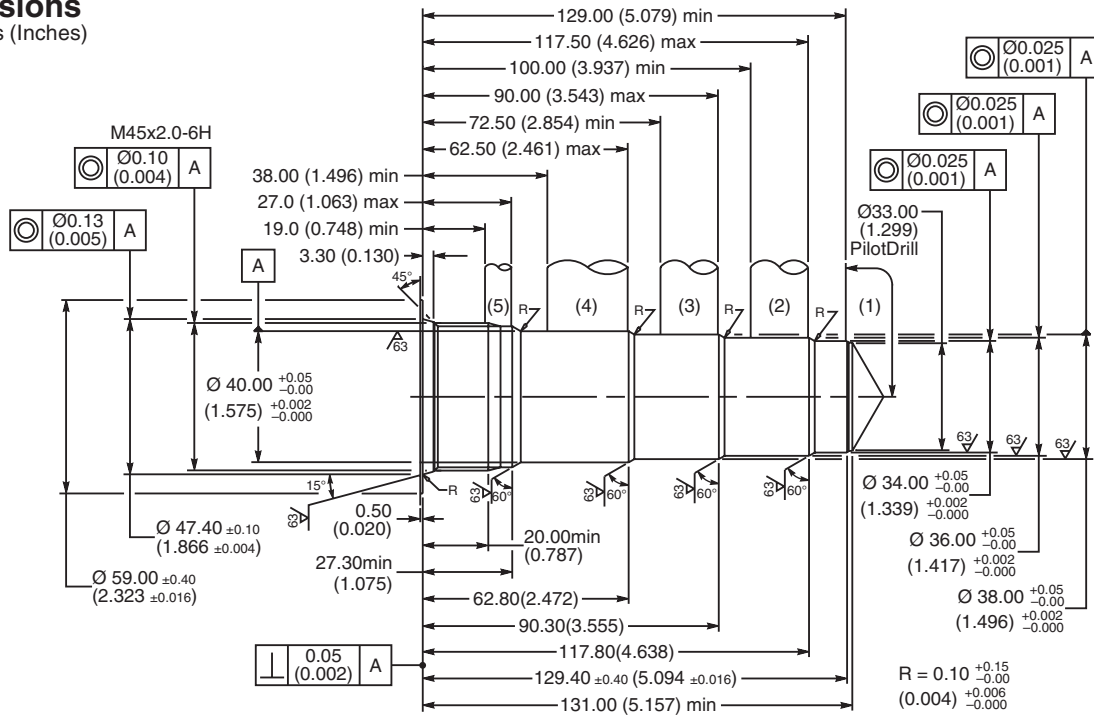

Ordering Information

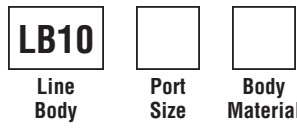

Code	Port Size
316	1-1/4 BSP (Main) 3/8 BSP (Aux)
317	1-1/4 SAE (Main) 3/8 SAE (Aux)

Code	Body Material
A	Aluminum
S	Steel

Cavity Tooling (100-1 Cavity)	
Pilot Drill Ø	33.00 (1.30)
Step Drill	8DS31350
Reamer (Alum)	8RM31050A
Reamer (Steel)	8RM31050S
Counterbore	8CB31119
Tap	8TP31218

- CV Check Valves
- SH Shuttle Valves
- LM Load/Motor Controls
- FC Flow Controls
- PC Pressure Controls
- LE Logic Elements
- DC Directional Controls
- MV Manual Valves
- SV Solenoid Valves
- PV Proportional Valves
- CE Coils & Electronics
- BC Bodies & Cavities
- TD Technical Data

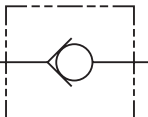
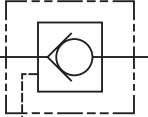
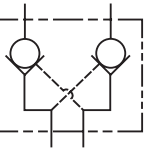
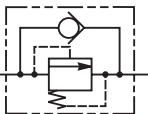
	SERIES	CAVITY	DESCRIPTION	FLOW LPM/GPM	PRESSURE BAR/PSI	PAGE NO.		
	STANDARD CHECKS							
		D1A060	2U	Check Valve Insert, Ball Type	145/38	420/6000	CV5	
		D1B125	2C	Check Valve Insert, Ball Type	500/132	420/6000	CV6	
		D0WB2	CAVOW-2	Cartridge Check, Ball Type	3.5/0.9	420/6000	CV7	
		D02B2	C08-2	Cartridge Check, Ball Type	45/12	420/6000	CV8	
	☆	CVH081P	C08-2	Cartridge Check, Poppet Type	38/10	350/5000	CV9	
	☆	CVH103P	C10-2	Cartridge Check, Poppet Type	60/16	350/5000	CV10	
		D04B2	C10-2	Cartridge Check, Ball Type	160/42	420/6000	CV11	
		CVH121P	C12-2	Cartridge Check, Poppet Type	121/32	350/5000	CV12	
		D06B2P	C16-2	Cartridge Check, Poppet Type	280/74	420/6000	CV13	
		CVH161P	C16-2	Cartridge Check, Poppet Type	226/60	350/5000	CV14	
		CVH201P	C20-2	Cartridge Check, Poppet Type	303/80	350/5000	CV15	
	☆	CVH104P	C10-2	Cartridge Check, Poppet Type 2 to 1 Flow Path	19/5	350/5000	CV16	
		D06C2	C16-2	Cartridge Check, Poppet Type 2 to 1 Flow Path	500/132	420/6000	CV17	
		PILOT OPERATED CHECKS						
			CP084P	C08-3	Single P.O. Check, Pilot on Port 1	19/5	207/3000	CV18
		☆	CPH104P	C10-3	Single P.O. Check, Pilot on Port 1	30/8	350/5000	CV19
			CPH124P	C12-3	Single P.O. Check, Pilot on Port 1	75/20	350/5000	CV20
☆		CSP(H)081		Single P.O. Check Package	38/10	350/5000	CV21-22	
☆		CSP(H)103		Single P.O. Check Package	60/16	350/5000	CV23-24	
		CSP(H)161		Single P.O. Check Package, Steel Body	226/60	350/5000	CV25-26	
		D4A020	53-1	Single P.O. Check, Pilot on Port 3	30/8	420/6000	CV27	
		D4A040	68-1	Single P.O. Check, Pilot on Port 3	60/16	420/6000	CV28	
		D3B125	3C	Single P.O. Check, Pilot on Port 3	150/40	420/6000	CV29	
		CPC101P	C10-3	Pilot to Close Check, Pilot on Port 3	20/5	420/6000	CV30	
		DUAL PILOT OPERATED CHECKS						
		CPD084P	C08-4	Dual P.O. Check Cartridge	19/5	207/3000	CV32	
	☆	CDP(H)081		Dual P.O. Check Package	38/10	350/5000	CV33-34	
	☆	CDP(H)103		Dual P.O. Check Package	60/16	350/5000	CV35-36	
	CDP(H)161		Dual P.O. Check Package, Steel Body	226/60	350/5000	CV37-38		
	CHECK WITH RELIEF							
		D04F2	C10-2	Check With Thermal Relief, Relieving Port 2 to 1	130/40	420/6000	CV39	

*Rated to 207 Bar/3000 PSI with Aluminum Body.

☆ Denotes New Winner's Circle Product Line.



CV

Check
Valves

SH

Shuttle
Valves

LM

Load/Motor
Controls

FC

Flow
Controls

PC

Pressure
Controls

LE

Logic
Elements

DC

Directional
Controls

MV

Manual
Valves

SV

Solenoid
Valves

PV

Proportional
Valves

CE

Coils &
Electronics

BC

Bodies &
Cavities

TD

Technical
Data**INTRODUCTION:**

This technical tips section is designed to help familiarize you with the Parker line of Check Valves. In this section we present the products that are new to this catalog as well as some design features of our checks valves. In addition, we present common options available to help you in selecting products for your application. Finally we give a brief synopsis of the operation and applications of the various product offered in this section.

NEW PRODUCTS:

There are several new additions and product improvements to our Check Valve product line.

Here are just some of the general design features and advantages to the "Winner's Circle" check valve.

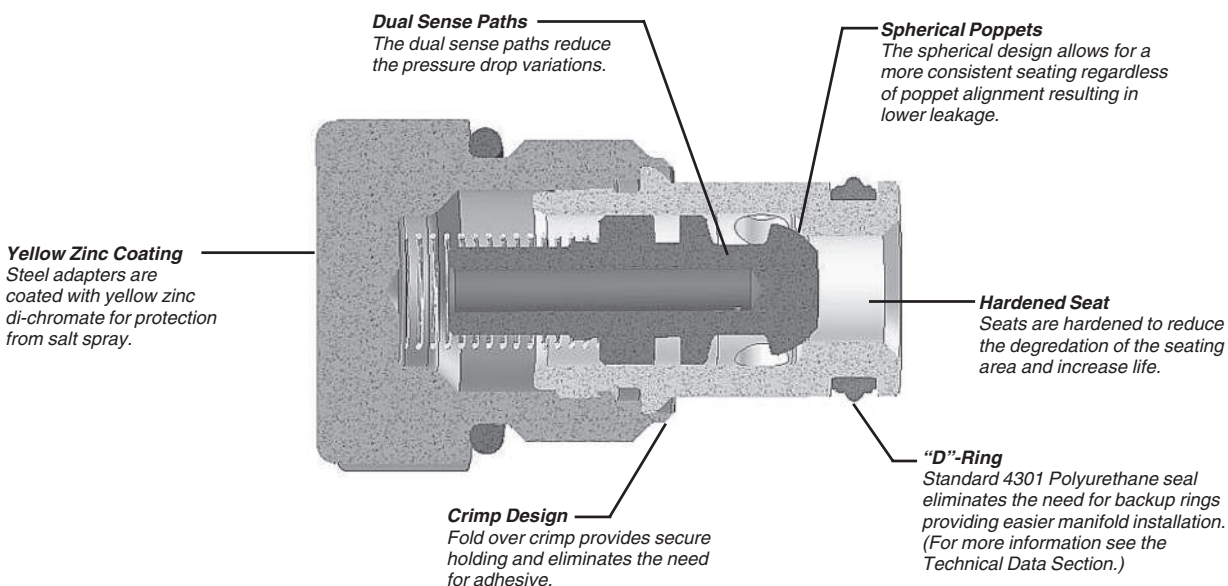
**COMMON OPTIONS:**

Since check valves and shuttles are fairly simple components, there are very few options. Here are the standard options you will find.

Seals: The Winner's Circle products feature a standard 4301 Polyurethane "D"-Ring. The "D"-Ring eliminates the need for backup rings. The majority of the products are available in Nitrile or Fluorocarbon Seals. You should match the seal compatibility to the temperature and fluid being used in your application.

Crack Pressure: Parker offers a number of standard crack pressure options for each valve. Check the model code pages for these options. The crack pressure is defined as the minimum amount of pressure that is needed to unseat the poppet. In pilot operated check applications, you may want to go with a slightly higher cracking pressure to keep the piston weight, friction, and drag from accidentally unseating the poppet.

Pilot Piston Seal: On the pilot piston style pilot operated check valves, Parker offers the option to place a seal on the piston to reduce the leakage across the piston. **Note:** Sealing the pilot piston does not decrease the leakage across the poppet. In other words, if you are trying to reduce the leakage from the actuator port, sealing the piston will not help. While most applications do not require a seal on the piston, it can be advantageous in applications with very small pump flows where the lost fluid would have a high impact on actuator speed.

PRODUCT TYPES / APPLICATIONS

Check Valve - Poppet Type

Check valves are poppet style elements that allow free flow in one direction while preventing flow in the reverse direction.

They can be used to isolate portions of a hydraulic circuit or to provide a free flow path around a restrictive valve.

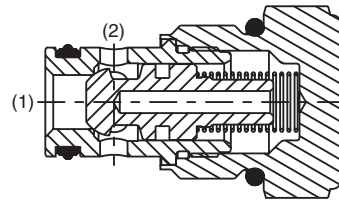
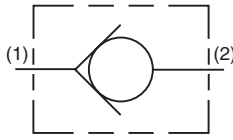

OPERATION - Pressure on the inlet (port 1) of the check valve creates a force against the poppet, pushing it off its seat and permitting free flow to port 2. Reverse flow through the check is blocked by the poppet.

Check Valve - Ball Type

Ball type check valves are check valves that use a hardened steel ball to seal against the valve seat as opposed to a poppet. They are simple in their design and provide low leakage over the life of the system.

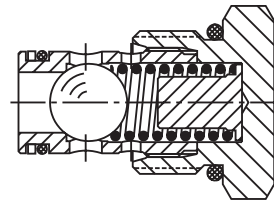
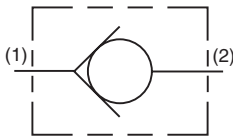

OPERATION - Pressure on the inlet (port 1) of the check valve creates a force on the steel ball pushing it off of its seat and permitting free flow to port 2. Reverse flow through the check is blocked by the steel ball on the seat.

Side to Nose Check Valve

Side to nose check valves are a special type of check valve where the free flow path is from the side of the cartridge valve to the nose. They functionally are the same as the standard check valve. Side to nose check valves are occasionally used by manifold designers to simply the flow path design of their blocks.

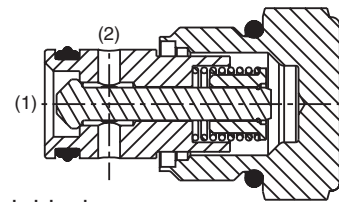
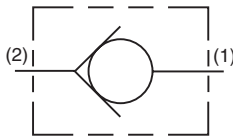

OPERATION - Pressure on the inlet (port 2) of the check valve creates a force against the poppet, pushing it off its seat and permitting free flow to port 1. Reverse flow through the check is blocked by the poppet.

CV
Check Valves
SH
Shuttle Valves
LM
Load/Motor Controls
FC
Flow Controls
PC
Pressure Controls
LE
Logic Elements
DC
Directional Controls
MV
Manual Valves
SV
Solenoid Valves
PV
Proportional Valves
CE
Coils & Electronics
BC
Bodies & Cavities
TD
Technical Data

CV

Check Valves

SH

Shuttle Valves

LM

Load/Motor Controls

FC

Flow Controls

PC

Pressure Controls

LE

Logic Elements

DC

Directional Controls

MV

Manual Valves

SV

Solenoid Valves

PV

Proportional Valves

CE

Coils & Electronics

BC

Bodies & Cavities

TD

Technical Data

Pilot Operated Check Valve

Pilot operated check valves (also referred to as P.O. check valves), are check valves which can be opened by an external pilot pressure. Thus, P.O. checks, block flow in one direction, like standard check valves, but can be released once an adequate pilot pressure is applied. Free flow is allowed in the reverse direction. P.O. checks are often used to positively lock a dual acting cylinder. There are two types of pilot operated check valves; threaded cartridge style and pilot piston style. These valves work best when used in conjunction with a control valve that vents the valve ports to tank when centered.

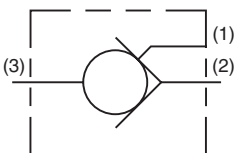

Cartridge Style P.O. Check Valve

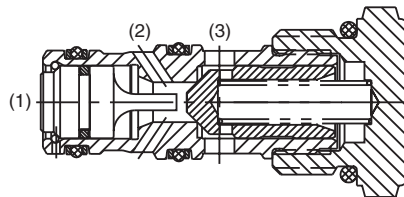

Single Pilot Piston Style P.O. Check Valve

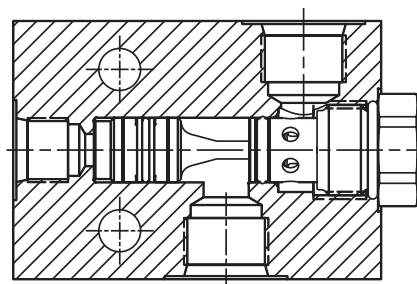

Dual Pilot Piston Style P.O. Check Valve

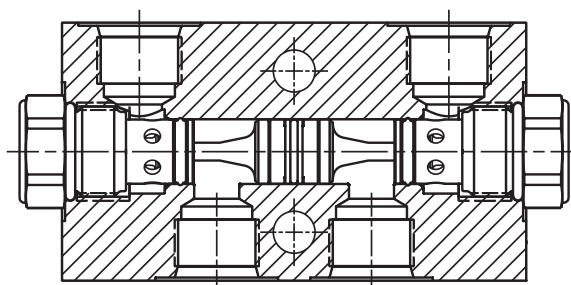

OPERATION - In the absence of adequate pilot pressure, the poppet remains seated preventing flow from the actuator port (port 3) to the valve port (port 2). Once adequate pilot pressure is applied at the pilot port (port 1), the internal pilot piston unseats the check poppet permitting flow from port 3 to port 2. The amount of pressure needed at port 1 to unseat the check valve is determined by the pilot ratio of the pilot piston to the poppet seat diameter. If you have a pilot operated check valve with a 3:1 ratio pilot piston, then you would need a pilot pressure at port 1 that is 1/3 of the pressure being checked at port 3 plus the spring. For example, if you had 3000 psi on port 3 and a 5 psi spring and a 3:1 pilot ratio, it would take 1002 psi $[(3000 \text{ psi} + 5 \text{ psi}) / 3]$ to release the check valve. Free flow is permitted from the valve port (port 2) to the cylinder port (port 3).

Check Valve With Thermal Relief

The check valve with thermal relief performs the same function as a standard check valve. It allows free flow in one direction. In the opposite direction, it performs as a normal check valve preventing flow, while also venting excess pressure caused by the thermal expansion of fluid. This type of valve can be used with an external pilot piston to provide a pilot operated valve that will vent trapped pressure due to thermal expansion. These valves work best when used in conjunction with a control valve that vents the valve ports to tank when centered.

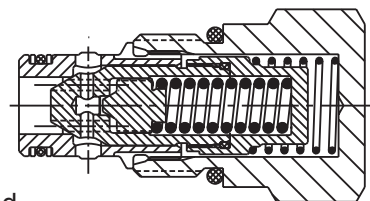
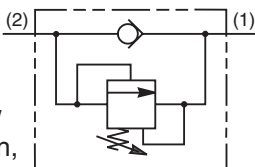

OPERATION - The check valve is a guided poppet design. As the pressure on the inlet exceeds the spring rate, the poppet is pushed off of its seat allowing flow to pass. Once the pressure on the inlet side drops below the spring force, the spring then pushes the poppet back on its seat blocking flow from the outlet to the inlet of the check valve. If the pressure on the outlet side of the check valve (when it is in a load holding function) rises (through thermal expansion), the direct acting relief will vent the excess pressure caused by the thermal expansion to the inlet side of the check.

Pilot to Close Check

Pilot to close check valves are unique 2 way valves that act as a check valve, allowing free flow in one direction and blocking flow from the opposite direction. When an external pilot pressure is applied, flow is blocked from both directions.

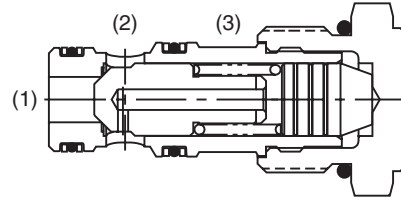
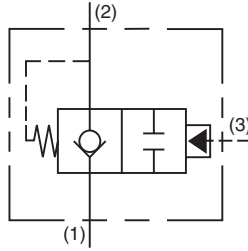

These products are ideal for regeneration circuits. See sample diagram shown.

OPERATION - In the absence of adequate pilot pressure, the valve functions as a simple check valve, allowing free flow from port 1 to port 2. When adequate pilot pressure at port 3 is applied, the pilot piston holds the poppet closed, blocking flow in both directions.

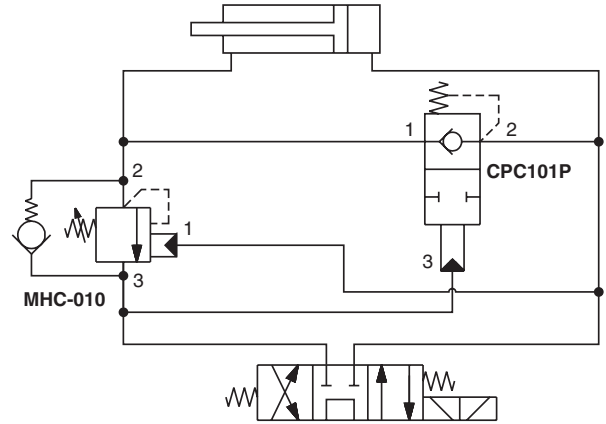

CV
Check Valves
SH
Shuttle Valves
LM
Load/Motor Controls
FC
Flow Controls
PC
Pressure Controls
LE
Logic Elements
DC
Directional Controls
MV
Manual Valves
SV
Solenoid Valves
PV
Proportional Valves
CE
Coils & Electronics
BC
Bodies & Cavities
TD
Technical Data

Technical Information

- CV Check Valves
- SH Shuttle Valves
- LM Load/Motor Controls
- FC Flow Controls
- PC Pressure Controls
- LE Logic Elements
- DC Directional Controls
- MV Manual Valves
- SV Solenoid Valves
- PV Proportional Valves
- CE Coils & Electronics
- BC Bodies & Cavities
- TD Technical Data

General Description

Ball Type, Check Valve Insert.

Features

- For inserting inside manifold blocks
- High flow capacity
- Minimal leakage - less than 3 drops/min.
- Simple construction - extremely cost effective
- Range of cracking pressures available
- Good contamination tolerance
- All external parts zinc plated

Performance Curve

Pressure Drop vs. Flow (Through cartridge only)

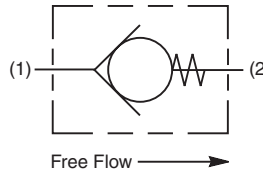
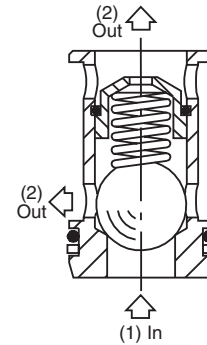
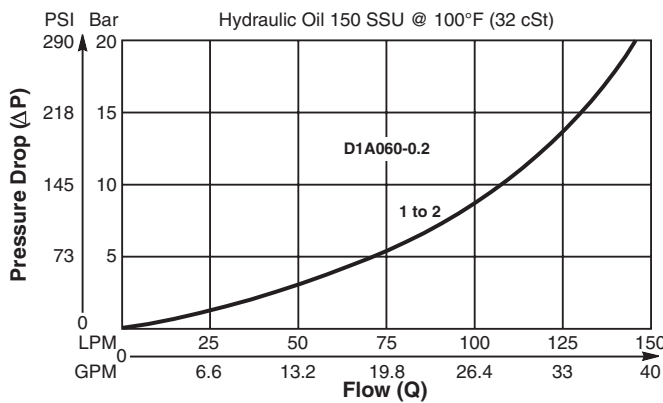

Dimensions Millimeters (Inches)

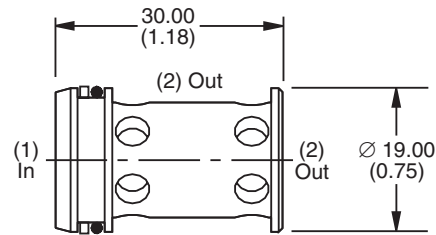

Specifications

Rated Flow	145 LPM (38 GPM)
Nominal Flow @ 7 Bar (100 PSI)	90 LPM (24 GPM)
Maximum Inlet Pressure	420 Bar (6000 PSI)
Leakage at 150 SSU (32 cSt)	Less than 3 drops/min.
Cartridge Material	Steel operating parts, hardened steel ball.
Operating Temp. Range/Seals	-40°C to +93.3°C (Nitrile, Buna-N) (-40°F to +200°F) -31.7°C to +121.1°C (Fluorocarbon) (-25°F to +250°F)
Fluid Compatibility/Viscosity	Mineral-based or synthetic with lubricating properties at viscosities of 45 to 2000 SSU (6 to 420 cSt)
Filtration	ISO code 16/13, SAE Class 4 or better
Approx. Weight	.085 kg (.19 lbs.)
Cavity	2U (See BC Section for more details)

Ordering Information

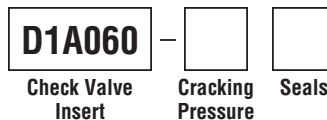

Code	Cracking Pressure
0.2	0.2 Bar (3 PSI) Std.
1.0	1.0 Bar (15 PSI)
2.0	2.0 Bar (30 PSI)
3.0	3.0 Bar (45 PSI)
5.0	5.0 Bar (72 PSI)
7.0	7.0 Bar (100 PSI)
10.0	10.0 Bar (145 PSI)

Code	Seals / Kit No.
N	Nitrile, Buna-N / (SK30019N-1)
V	Fluorocarbon / (SK30019V-1)

Order Bodies Separately



Code	Porting
205	1/2" BSP
220	1/2" SAE

Code	Body Material
S	Steel

Technical Information

General Description

Poppet Type, Check Valve Insert.

Features

- For inserting inside manifold blocks
- High flow capacity
- Minimal leakage - less than 3 drops/min.
- Simple construction - extremely cost effective
- Range of cracking pressures available
- Good contamination tolerance
- All external parts zinc plated

Performance Curve

Pressure Drop vs. Flow (Through cartridge only)

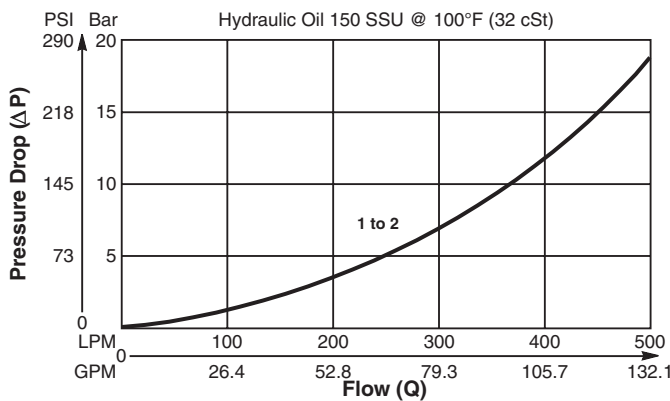

Specifications

Rated Flow	500 LPM (132 GPM)
Nominal Flow @ 7 Bar (100 PSI)	300 LPM (79 GPM)
Maximum Inlet Pressure	420 Bar (6000 PSI)
Leakage at 150 SSU (32 cSt)	Less than 3 drops/min.
Cartridge Material	Steel operating parts, hardened steel poppet.
Operating Temp. Range/Seals	-40°C to +93.3°C (Nitrile, Buna-N) (-40°F to +200°F) -31.7°C to +121.1°C (Fluorocarbon) (-25°F to +250°F)
Fluid Compatibility/Viscosity	Mineral-based or synthetic with lubricating properties at viscosities of 45 to 2000 SSU (6 to 420 cSt)
Filtration	ISO code 16/13, SAE Class 4 or better
Approx. Weight	.06 kg (.13 lbs.)
Cavity	2C (See BC Section for more details)

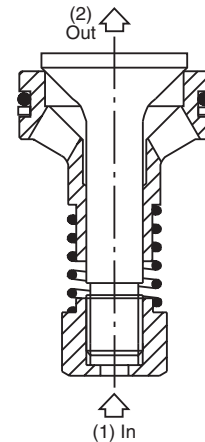
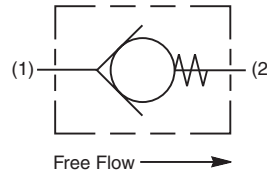

Dimensions Millimeters (Inches)

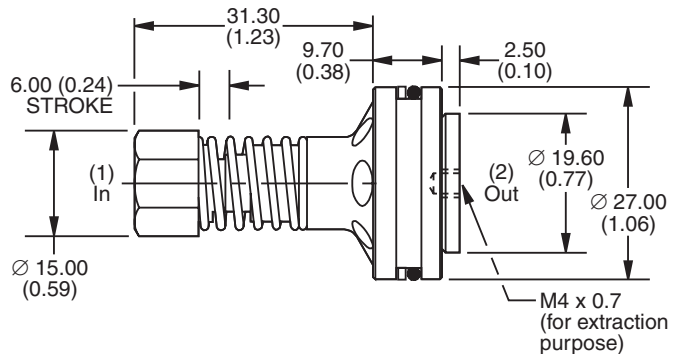

Ordering Information

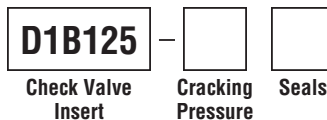

Code	Cracking Pressure
0.0	0 Bar (0 PSI)
0.1	0.1 Bar (1.5 PSI)
0.2	0.2 Bar (3 PSI)
1.0	1.0 Bar (15 PSI) Std.
2.0	2.0 Bar (30 PSI)
3.0	3.0 Bar (45 PSI)
5.0	5.0 Bar (72 PSI)

Code	Seals / Kit No.
N	Nitrile, Buna-N / (SK30014N-1)
V	Fluorocarbon / (SK30014V-1)

Order Bodies Separately



Code	Porting
210	1" BSP
212	1" SAE

Code	Body Material
S	Steel

CV

Check Valves

SH

Shuttle Valves

LM

Load/Motor Controls

FC

Flow Controls

PC

Pressure Controls

LE

Logic Elements

DC

Directional Controls

MV

Manual Valves

SV

Solenoid Valves

PV

Proportional Valves

CE

Coils & Electronics

BC

Bodies & Cavities

TD

Technical Data

Technical Information

CV

Check Valves

SH

Shuttle Valves

LM

Load/Motor Controls

FC

Flow Controls

PC

Pressure Controls

LE

Logic Elements

DC

Directional Controls

MV

Manual Valves

SV

Solenoid Valves

PV

Proportional Valves

CE

Coils & Electronics

BC

Bodies & Cavities

TD

Technical Data

General Description

Miniature Ball Type Check Valve. For additional information see Technical Tips on pages CV1-CV4.

Features

- Low leakage - less than 3 drops/min.
- Ball type construction for cost effective design
- Extremely compact
- Good contamination tolerance
- All external parts zinc plated

Performance Curve

Pressure Drop vs. Flow (Through cartridge only)

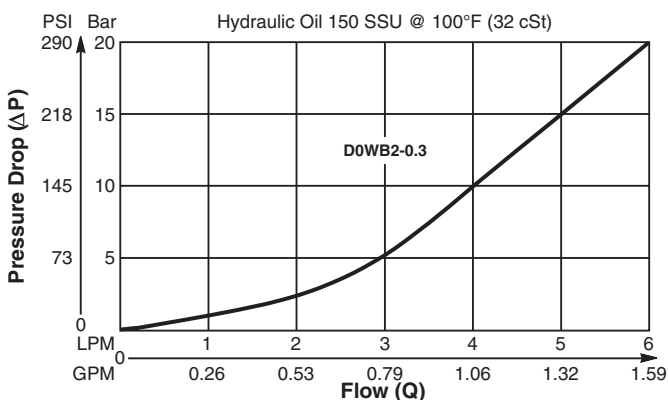

Specifications

Rated Flow	6 LPM (1.6 GPM)
Nominal Flow @ 7 Bar (100 PSI)	3.5 LPM (0.9 GPM)
Maximum Inlet Pressure	420 Bar (6000 PSI)
Leakage at 150 SSU (32 cSt)	Less than 3 drops/min.
Cartridge Material	Steel operating parts, hardened steel ball.
Operating Temp. Range/Seals	-40°C to +93.3°C (Nitrile, Buna-N) (-40°F to +200°F) -31.7°C to +121.1°C (Fluorocarbon) (-25°F to +250°F)
Fluid Compatibility/Viscosity	Mineral-based or synthetic with lubricating properties at viscosities of 45 to 2000 SSU (6 to 420 cSt)
Filtration	ISO code 16/13, SAE Class 4 or better
Approx. Weight	.012 kg (.026 lbs.)
Cavity	CAV0W-2 (See BC Section for more details)

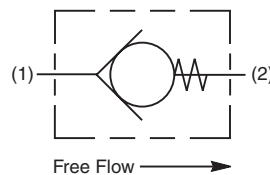
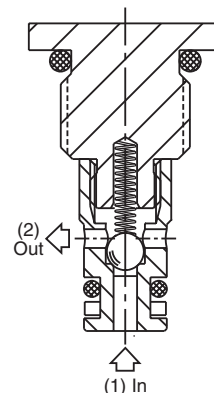

Dimensions Millimeters (Inches)

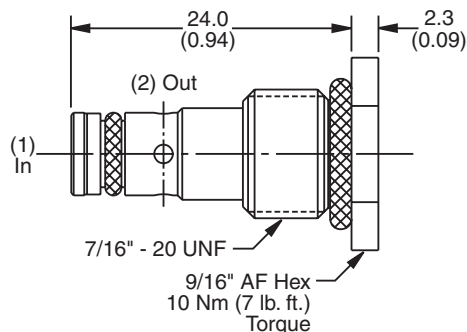

Ordering Information

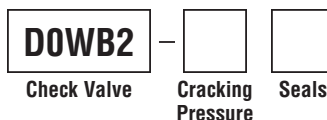

Code	Cracking Pressure
0.3	0.3 Bar (4 PSI)

Code	Seals / Kit No.
N	Nitrile, Buna-N / (SK30519N-1)
V	Fluorocarbon / (SK30519V-1)

Order Bodies Separately



Code	Porting
795	1/4" SAE
796	1/4" BSP

Code	Body Material
A	Aluminum
S	Steel

Technical Information

General Description

Ball Type Check Valve. For additional information see Technical Tips on pages CV1-CV4.

Features

- Low leakage - less than 3 drops/min.
- Ball type construction for cost effective design
- Single and dual pilot pistons available to create pilot to open check
- Range of cracking pressures available - up to 25 Bar (362 PSI)
- Good contamination tolerance
- All external parts zinc plated

Performance Curve

Pressure Drop vs. Flow (Through cartridge only)

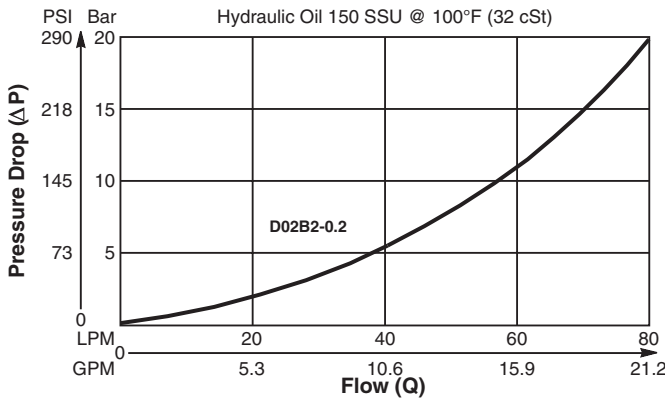

Specifications

Rated Flow	80 LPM (21 GPM)
Nominal Flow @ 7 Bar (100 PSI)	45 LPM (12 GPM)
Maximum Inlet Pressure	420 Bar (6000 PSI)
Leakage at 150 SSU (32 cSt)	Less than 3 drops/min.
Cartridge Material	Steel operating parts, hardened steel ball.
Operating Temp. Range/Seals	-40°C to +93.3°C (Nitrile, Buna-N) (-40°F to +200°F) -31.7°C to +121.1°C (Fluorocarbon) (-25°F to +250°F)
Fluid Compatibility/Viscosity	Mineral-based or synthetic with lubricating properties at viscosities of 45 to 2000 SSU (6 to 420 cSt)
Filtration	ISO code 16/13, SAE Class 4 or better
Approx. Weight	.05 kg (.11 lbs.)
Cavity	C08-2 (See BC Section for more details)

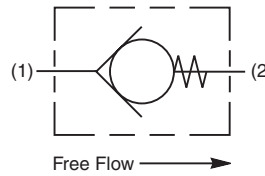
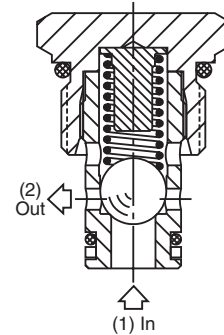

Dimensions Millimeters (Inches)

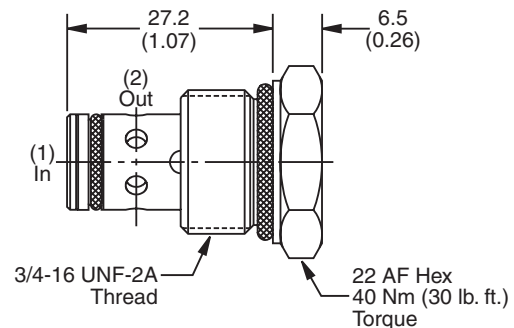

Ordering Information

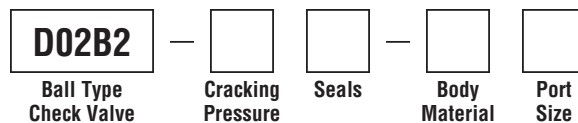

Code	Cracking Pressure
0.0	0.0 Bar (0 PSI)
0.2	0.2 Bar (3 PSI) Std.
1.0	1.0 Bar (15 PSI)
1.5	1.5 Bar (22 PSI)
2.1	2.1 Bar (30 PSI)
2.5	2.5 Bar (36 PSI)
3.4	3.4 Bar (50 PSI)
4.0	4.0 Bar (58 PSI)
6.0	6.0 Bar (87 PSI)
6.9	6.9 Bar (100 PSI)
10.0	10.0 Bar (145 PSI)
17.0	17.0 Bar (247 PSI)
20.0	20.0 Bar (290 PSI)
25.0	25.0 Bar (362 PSI)

Code	Seals / Kit No.
N	Nitrile, Buna-N / (SK30515N-1)
V	Fluorocarbon / (SK30515V-1)

Code	Body Material
Omit	Steel
A	Aluminum

Code	Port Size	Body Part No.
Omit	Cartridge Only	
4P	1/4" NPTF	(B08-2-*4P)
6P	3/8" NPTF	(B08-2-*6P)
4T	SAE-4	(B08-2-*4T)
6T	SAE-6	(B08-2-*6T)
6B	3/8" BSPG	(B08-2-*6B)

* Add "A" for aluminum, omit for steel.

Technical Information

- CV Check Valves
- SH Shuttle Valves
- LM Load/Motor Controls
- FC Flow Controls
- PC Pressure Controls
- LE Logic Elements
- DC Directional Controls
- MV Manual Valves
- SV Solenoid Valves
- PV Proportional Valves
- CE Coils & Electronics
- BC Bodies & Cavities
- TD Technical Data

General Description

Cartridge Style Check Valve. For additional information see Technical Tips on pages CV1-CV4.



Features

- Spherical poppet for low leakage
- “D”-Ring eliminates back-up rings
- Dual sense paths for reduced ΔP
- All external parts zinc plated

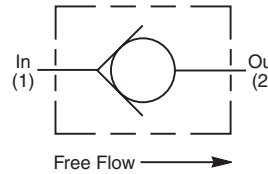
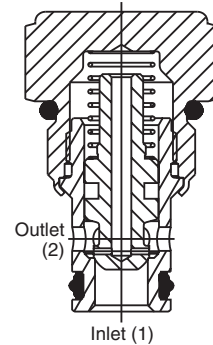

Performance Curve

Pressure Drop vs. Flow (Through cartridge only)

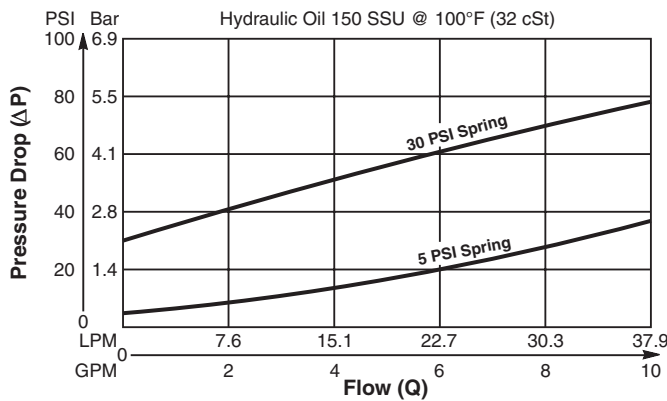

Dimensions Millimeters (Inches)

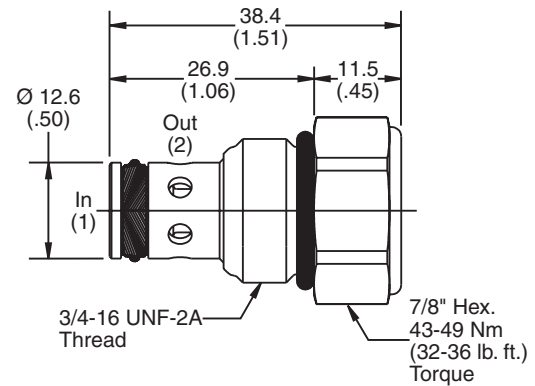

Specifications

Rated Flow	38 LPM (10 GPM)
Maximum Inlet Pressure	350 Bar (5000 PSI)
Leakage at 150 SSU (32 cSt)	2 drops/min. (.13 cc/min.) at 350 Bar (5000 PSI)
Cartridge Material	All parts steel. All operating parts hardened steel.
Operating Temp. Range/Seals	-45°C to +93.3°C (“D” Ring) (-50°F to +200°F) -31.7°C to +121.1°C (Fluorocarbon) (-25°F to +250°F)
Fluid Compatibility/Viscosity	Mineral-based or synthetic with lubricating properties at viscosities of 45 to 2000 SSU (6 to 420 cSt)
Filtration	ISO code 16/13, SAE Class 4 or better
Approx. Weight	.10 kg (0.2 lbs.)
Cavity	C08-2 (See BC Section for more details)
Form Tool	Rougher None Finisher NFT08-2F

Ordering Information

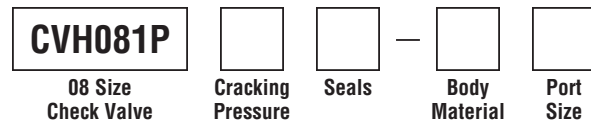

Code	Cracking Pressure
Omit	0.3 Bar (5 PSI)
10	0.7 Bar (10 PSI)
30	2.1 Bar (30 PSI)
65	4.5 Bar (65 PSI)
100	6.9 Bar (100 PSI)
150	10.4 Bar (150 PSI)

Code	Body Material
Omit	Steel
A	Aluminum

Code	Seals / Kit No.
Omit	“D”-Ring / (SK08-2)
N	Nitrile / (SK08-2N)
V	Fluorocarbon / (SK08-2V)

Code	Port Size	Body Part No.
Omit	Cartridge Only	
4P	1/4” NPTF	(B08-2-*4P)
6P	3/8” NPTF	(B08-2-*6P)
4T	SAE-4	(B08-2-*4T)
6T	SAE-6	(B08-2-*6T)
6B	3/8” BSPG	(B08-2-*6B)

* Add “A” for aluminum, omit for steel.

Technical Information

General Description

Cartridge Style Check Valve. For additional information see Technical Tips on pages CV1-CV4.



Features

- Spherical poppet for low leakage
- “D”-Ring eliminates back-up rings
- Dual sense paths for reduced ΔP
- All external parts zinc plated

Performance Curve

Pressure Drop vs. Flow (Through cartridge only)

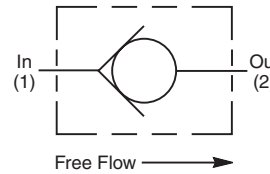
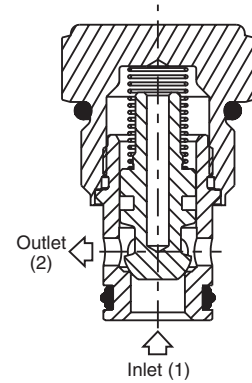
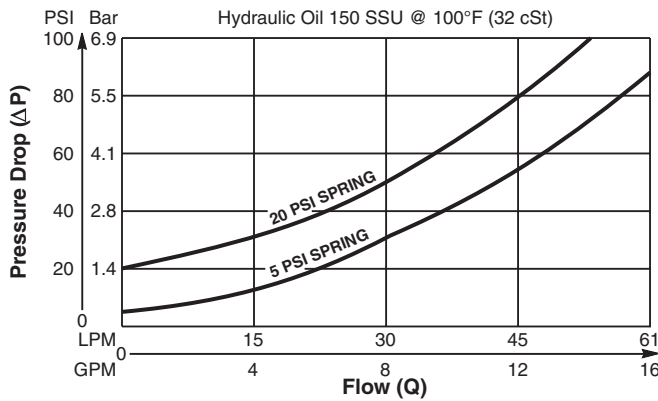

Dimensions Millimeters (Inches)

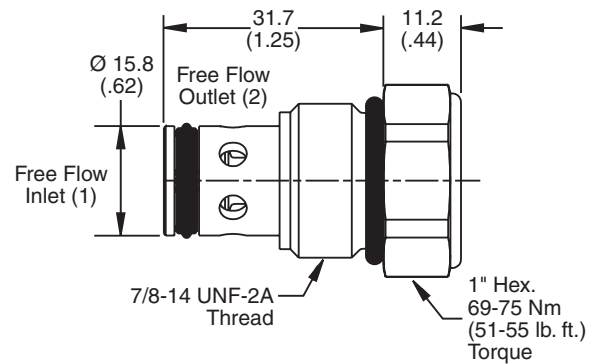

Specifications

Rated Flow	60 LPM (16 GPM)
Maximum Inlet Pressure	350 Bar (5000 PSI)
Leakage at 150 SSU (32 cSt)	2 drops/min. (.13 cc/min.) at 350 Bar (5000 PSI)
Cartridge Material	All parts steel. All operating parts hardened steel.
Operating Temp. Range/Seals	-45°C to +93.3°C (“D” Ring) (-50°F to +200°F) -31.7°C to +121.1°C (Fluorocarbon) (-25°F to +250°F)
Fluid Compatibility/Viscosity	Mineral-based or synthetic with lubricating properties at viscosities of 45 to 2000 SSU (6 to 420 cSt)
Filtration	ISO code 16/13, SAE Class 4 or better
Approx. Weight	.09 kg (0.2 lbs.)
Cavity	C10-2 (See BC Section for more details)
Form Tool	Rougher None Finisher NFT10-2F

Ordering Information

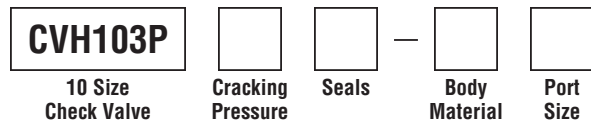

Code	Cracking Pressure
Omit	0.3 Bar (5 PSI)
20	1.4 Bar (20 PSI)
50	3.5 Bar (50 PSI)
65	4.5 Bar (65 PSI)
80	5.5 Bar (80 PSI)
100	6.9 Bar (100 PSI)

Code	Body Material
Omit	Steel
A	Aluminum

Code	Seals / Kit No.
Omit	“D”-Ring / (SK10-2)
N	Nitrile / (SK10-2N)
V	Fluorocarbon / (SK10-2V)

Code	Port Size	Body Part No.
Omit	Cartridge Only	
4P	1/4” NPTF	(B10-2-*4P)
6P	3/8” NPTF	(B10-2-*6P)
8P	1/2” NPTF	(B10-2-*8P)
6T	SAE-6	(B10-2-*6T)
8T	SAE-8	(B10-2-*8T)
T8T	SAE-8	(B10-2-T8T)†
6B	3/8” BSPG	(B10-2-6B)†

* Add “A” for aluminum, omit for steel.
† Steel body only.

CV
Check Valves

SH
Shuttle Valves

LM
Load/Motor Controls

FC
Flow Controls

PC
Pressure Controls

LE
Logic Elements

DC
Directional Controls

MV
Manual Valves

SV
Solenoid Valves

PV
Proportional Valves

CE
Coils & Electronics

BC
Bodies & Cavities

TD
Technical Data

Technical Information

- CV Check Valves
- SH Shuttle Valves
- LM Load/Motor Controls
- FC Flow Controls
- PC Pressure Controls
- LE Logic Elements
- DC Directional Controls
- MV Manual Valves
- SV Solenoid Valves
- PV Proportional Valves
- CE Coils & Electronics
- BC Bodies & Cavities
- TD Technical Data

General Description

Ball Type Check Valve. For additional information see Technical Tips on pages CV1-CV4.

Features

- Low leakage - less than 3 drops/min.
- Ball type construction for cost effective design
- Single and dual pilot pistons available to create pilot to open check
- Range of cracking pressures available
- Good contamination tolerance
- All external parts zinc plated

Performance Curve

Pressure Drop vs. Flow (Through cartridge only)

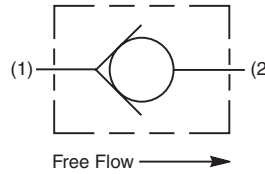
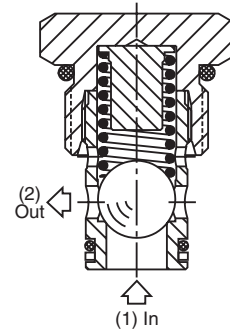
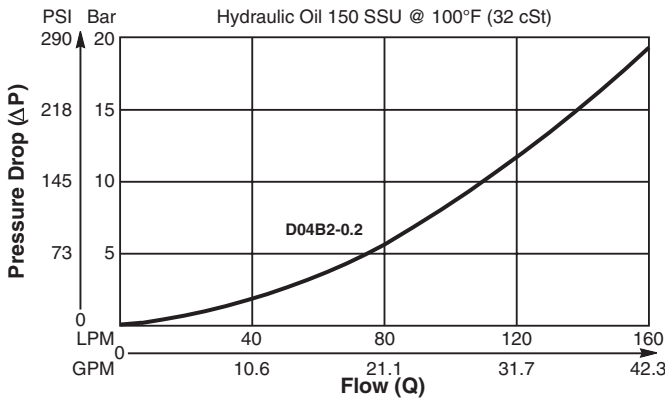

Dimensions Millimeters (Inches)

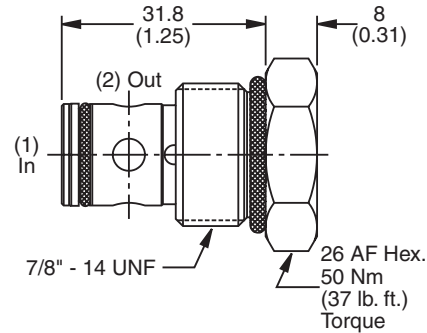

Specifications

Rated Flow	160 LPM (42 GPM)
Nominal Flow @ 7 Bar (100 PSI)	90 LPM (24 GPM)
Maximum Inlet Pressure	420 Bar (6000 PSI)
Leakage at 150 SSU (32 cSt)	3 drops/min.
Cartridge Material	Steel operating parts, hardened steel ball.
Operating Temp. Range/Seals	-40°C to +93.3°C (Nitrile, Buna-N) (-40°F to +200°F) -31.7°C to +121.1°C (Fluorocarbon) (-25°F to +250°F)
Fluid Compatibility/Viscosity	Mineral-based or synthetic with lubricating properties at viscosities of 45 to 2000 SSU (6 to 420 cSt)
Filtration	ISO code 16/13, SAE Class 4 or better
Approx. Weight	.08 kg (.18 lbs.)
Cavity	C10-2 (See BC Section for more details)

Ordering Information

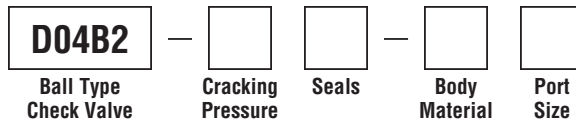

Code	Cracking Pressure
0.0	0.0 Bar (0 PSI)
0.2	0.2 Bar (3 PSI) Std.
1.0	1.0 Bar (15 PSI)
2.1	2.1 Bar (30 PSI)
3.4	3.4 Bar (50 PSI)
6.9	6.9 Bar (100 PSI)
10.0	10.0 Bar (145 PSI)
15.0	15.0 Bar (217 PSI)

Code	Body Material
Omit	Steel
A	Aluminum

Code	Port Size	Body Part No.
Omit	Cartridge Only	
4P	1/4" NPTF	(B10-2-*4P)
6P	3/8" NPTF	(B10-2-*6P)
8P	1/2" NPTF	(B10-2-*8P)
6T	SAE-6	(B10-2-*6T)
8T	SAE-8	(B10-2-*8T)
T8T	SAE-8	(B10-2-T8T)†
6B	3/8" BSPG	(B10-2-6B)†

Code	Seals / Kit No.
N	Nitrile, Buna-N / (SK30516N-1)
V	Fluorocarbon / (SK30516V-1)

* Add "A" for aluminum, omit for steel.
† Steel body only.



General Description

Cartridge Style Check Valve. For additional information see Technical Tips on pages CV1-CV4.

Features

- Hardened, precision ground parts for durability
- Fully guided poppet for smooth operation
- All external parts zinc plated

Performance Curve

Pressure Drop vs. Flow (Through cartridge only)

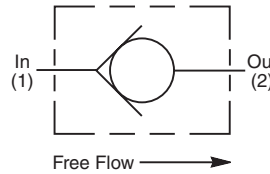
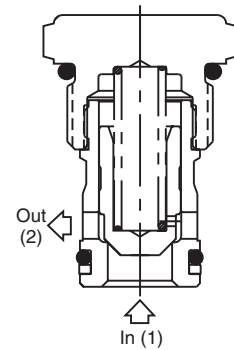
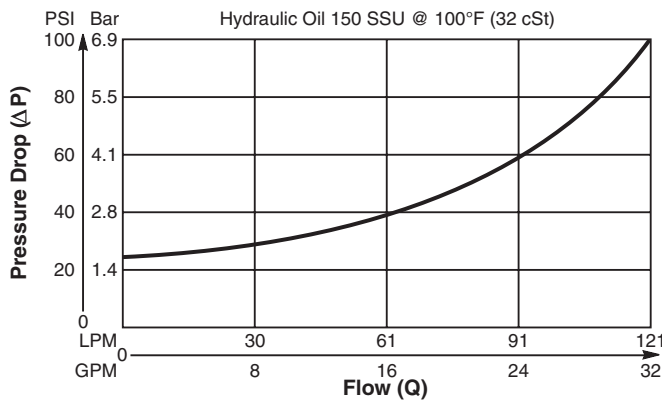

Dimensions Millimeters (Inches)

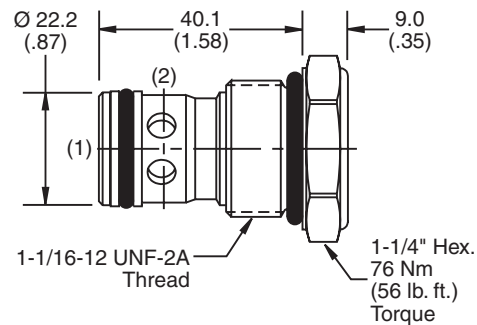

Specifications

Rated Flow	121 LPM (32 GPM)
Maximum Inlet Pressure	350 Bar (5000 PSI)
Leakage at 150 SSU (32 cSt)	5 drops/min. (.33 cc/min.) at 350 Bar (5000 PSI)
Cartridge Material	All parts steel. All operating parts hardened steel.
Operating Temp. Range/Seals	-40°C to +93.3°C (Nitrile) (-40°F to +200°F) -31.7°C to +121.1°C (Fluorocarbon) (-25°F to +250°F)
Fluid Compatibility/Viscosity	Mineral-based or synthetic with lubricating properties at viscosities of 45 to 2000 SSU (6 to 420 cSt)
Filtration	ISO code 16/13, SAE Class 4 or better
Approx. Weight	.14 kg (.30 lbs.)
Cavity	C12-2 (See BC Section for more details)
Form Tool	Rougher None Finisher NFT12-2F

Ordering Information

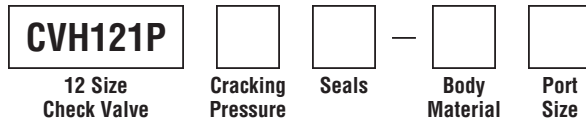

Code	Cracking Pressure
Omit	1.7 Bar (25 PSI)
65	4.5 Bar (65 PSI)

Code	Body Material
Omit	Steel
A	Aluminum

Code	Seals / Kit No.
Omit	Nitrile / (SK12-2)
V	Fluorocarbon / (SK12-2V)

Code	Port Size	Body Part No.
Omit	Cartridge Only	
12P	3/4" NPTF	(B12-2-*12P)
8T	SAE-8	(B12-2-*8T)
12T	SAE-12	(B12-2-*12T)
12B	3/4" BSPG	(B12-2-*12B)

*Add "A" for aluminum, omit for steel.

Technical Information

- CV Check Valves
- SH Shuttle Valves
- LM Load/Motor Controls
- FC Flow Controls
- PC Pressure Controls
- LE Logic Elements
- DC Directional Controls
- MV Manual Valves
- SV Solenoid Valves
- PV Proportional Valves
- CE Coils & Electronics
- BC Bodies & Cavities
- TD Technical Data

General Description

Poppet Type Check Valve. For additional information see Technical Tips on pages CV1-CV4.

Features

- Extra low pressure drop capability for systems up to 250 Bar
- Poppet type construction for minimal leakage - less than 3 drops/min.
- Hardened poppet for maximum durability
- Good contamination tolerance
- All external parts zinc plated

Performance Curve

Pressure Drop vs. Flow (Through cartridge only)

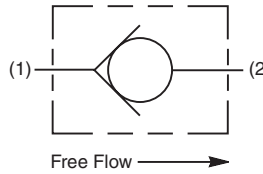
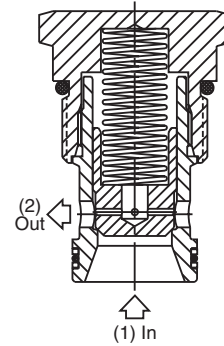
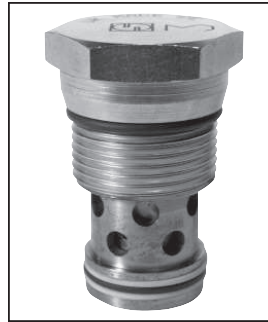
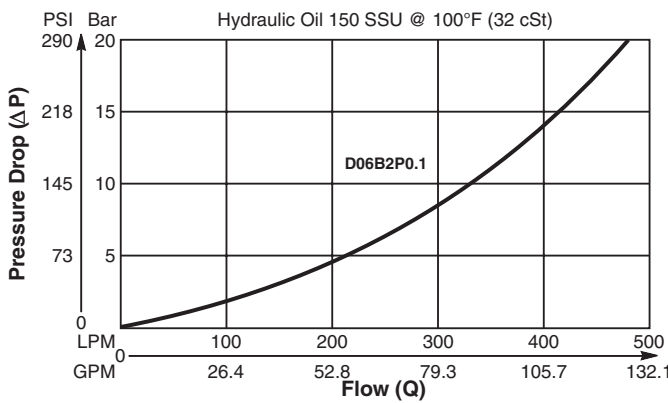

Dimensions Millimeters (Inches)

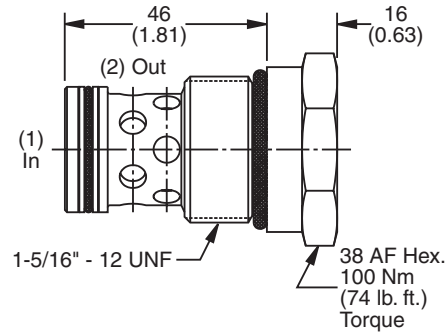

Specifications

Rated Flow	500 LPM (132 GPM)
Nominal Flow @ 7 Bar (100 PSI)	280 LPM (74 GPM)
Maximum Inlet Pressure	420 Bar (6000 PSI)
Leakage at 150 SSU (32 cSt)	Less than 3 drops/min.
Cartridge Material	Steel operating parts, hardened steel poppet.
Operating Temp. Range/Seals	-40°C to +93.3°C (Nitrile, Buna-N) (-40°F to +200°F) -31.7°C to +121.1°C (Fluorocarbon) (-25°F to +250°F)
Fluid Compatibility/Viscosity	Mineral-based or synthetic with lubricating properties at viscosities of 45 to 2000 SSU (6 to 420 cSt)
Filtration	ISO code 16/13, SAE Class 4 or better
Approx. Weight	.27 kg (.60 lbs.)
Cavity	C16-2 (See BC Section for more details)

Ordering Information

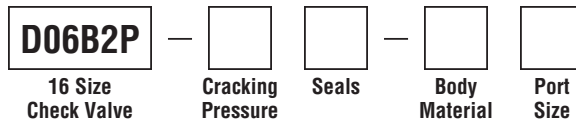

Code	Cracking Pressure
0.0	0.0 Bar (0 PSI)
0.1	0.1 Bar (1.5 PSI) Std.
1.0	1.0 Bar (15 PSI)
2.1	2.1 Bar (30 PSI)
3.4	3.4 Bar (50 PSI)
4.1	4.1 Bar (60 PSI)
7.5	7.5 Bar (109 PSI)

Code	Body Material
Omit	Steel
A	Aluminum

Code	Port Size	Body Part No.
Omit	Cartridge Only	
12P	3/4" NPTF	(B16-2-*12P)
16P	1" NPTF	(B16-2-*16P)
8T	SAE-8	(B16-2-*8T)
12T	SAE-12	(B16-2-*12T)
16T	SAE-16	(B16-2-*16T)
12B	3/4" BSPG	(B16-2-12B)†
16B	1" BSPG	(B16-2-*16B)

Code	Seals / Kit No.
N	Nitrile, Buna-N / (SK30507N-1)
V	Fluorocarbon / (SK30507V-1)

* Add "A" for aluminum, omit for steel.
† Steel body only.

Technical Information

General Description

Cartridge Style Check Valve.
For additional information see Technical Tips on pages CV1-CV4.

Features

- Hardened, precision ground parts for durability
- Fully guided poppet for smooth operation
- All external parts zinc plated

Performance Curve

Pressure Drop vs. Flow (Through cartridge only)

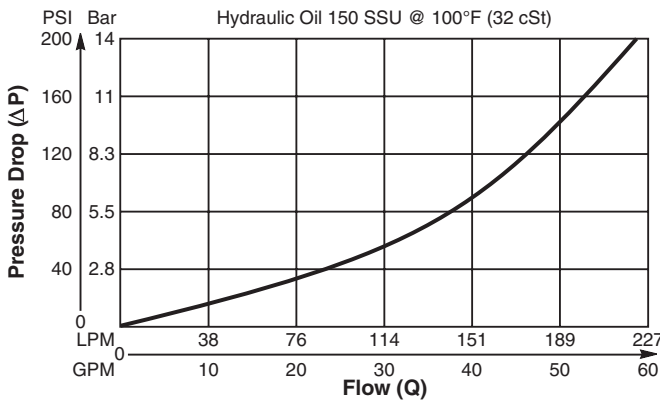

Specifications

Rated Flow	225 LPM (60 GPM)
Maximum Inlet Pressure	350 Bar (5000 PSI)
Leakage at 150 SSU (32 cSt)	5 drops/min. (.33 cc/min.) at 350 Bar (5000 PSI)
Cartridge Material	All parts steel. All operating parts hardened steel.
Operating Temp. Range/Seals	-40°C to +93.3°C (Nitrile) (-40°F to +200°F) -31.7°C to +121.1°C (Fluorocarbon) (-25°F to +250°F)
Fluid Compatibility/Viscosity	Mineral-based or synthetic with lubricating properties at viscosities of 45 to 2000 SSU (6 to 420 cSt)
Filtration	ISO code 16/13, SAE Class 4 or better
Approx. Weight	.27 kg (0.6 lbs.)
Cavity	C16-2 (See BC Section for more details)
Form Tool	Rougher None Finisher NFT16-2F

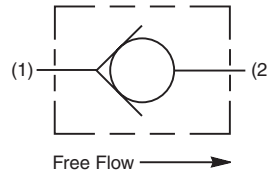
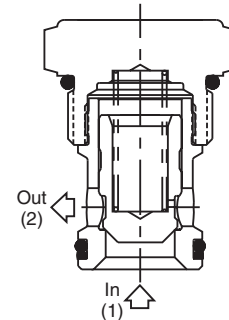

Dimensions Millimeters (Inches)

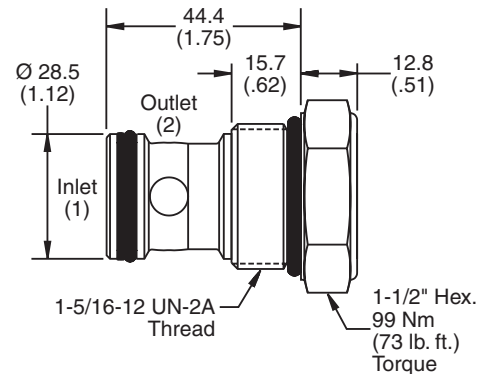

Ordering Information

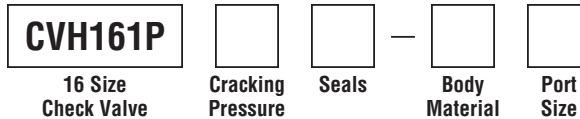

Code	Cracking Pressure
Omit	0.3 Bar (5 PSI)
20	1.4 Bar (20 PSI)
65	4.5 Bar (65 PSI)
125	8.6 Bar (125 PSI)
175	12.1 Bar (175 PSI)

Code	Body Material
Omit	Steel
A	Aluminum

Code	Seals / Kit No.
Omit	Nitrile / (SK16-2)
V	Fluorocarbon / (SK16-2V)

Code	Port Size	Body Part No.
Omit	Cartridge Only	
12P	3/4" NPTF	(B16-2-*12P)
16P	1" NPTF	(B16-2-*16P)
8T	SAE-8	(B16-2-*8T)
12T	SAE-12	(B16-2-*12T)
16T	SAE-16	(B16-2-*16T)
12B	3/4" BSPG	(B16-2-12B)†
16B	1" BSPG	(B16-2-*16B)

* Add "A" for aluminum, omit for steel.
† Steel body only.

Technical Information

- CV Check Valves
- SH Shuttle Valves
- LM Load/Motor Controls
- FC Flow Controls
- PC Pressure Controls
- LE Logic Elements
- DC Directional Controls
- MV Manual Valves
- SV Solenoid Valves
- PV Proportional Valves
- CE Coils & Electronics
- BC Bodies & Cavities
- TD Technical Data

General Description

Cartridge Style Check Valve.
For additional information see Technical Tips on pages CV1-CV4.

Features

- Hardened, precision ground parts for durability
- Fully guided poppet for smooth operation
- All external parts zinc plated

Performance Curve

Pressure Drop vs. Flow (Through cartridge only)

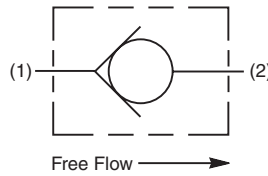
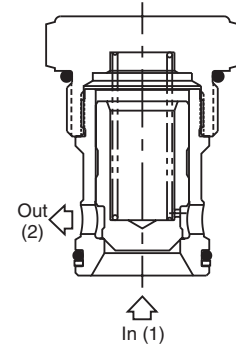
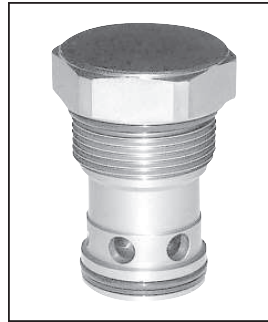
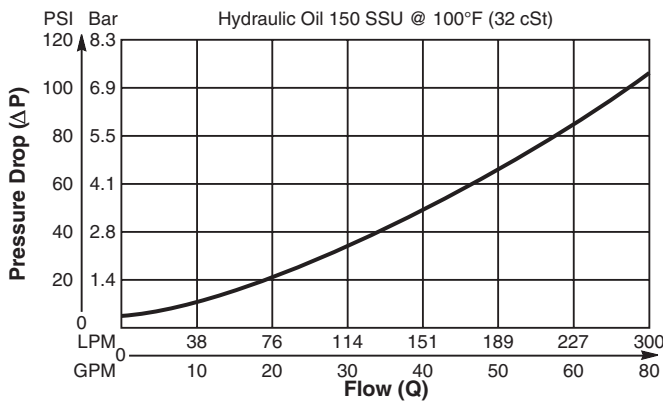

Dimensions Millimeters (Inches)

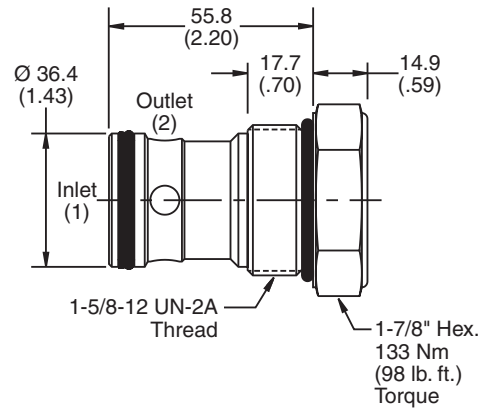

Specifications

Rated Flow	303 LPM (80 GPM)
Maximum Inlet Pressure	350 Bar (5000 PSI)
Leakage at 150 SSU (32 cSt)	5 drops/min. (.33 cc/min.) at 350 Bar (5000 PSI)
Cartridge Material	All parts steel. All operating parts hardened steel.
Operating Temp. Range/Seals	-40°C to +93.3°C (Nitrile) (-40°F to +200°F) -31.7°C to +121.1°C (Fluorocarbon) (-25°F to +250°F)
Fluid Compatibility/Viscosity	Mineral-based or synthetic with lubricating properties at viscosities of 45 to 2000 SSU (6 to 420 cSt)
Filtration	ISO code 16/13, SAE Class 4 or better
Approx. Weight	.27 kg (0.6 lbs.)
Cavity	C20-2 (See BC Section for more details)
Form Tool	Rougher None Finisher NFT20-2F

Ordering Information

CVH201P

20 Size **Cracking** **Seals** **Body** **Port**
Check Valve **Pressure** **Material** **Size**

Code	Cracking Pressure
Omit	0.3 Bar (5 PSI)
20	1.4 Bar (20 PSI)
65	4.5 Bar (65 PSI)

Code	Body Material
Omit	Steel

Code	Seals / Kit No.
Omit	Nitrile / (SK20-2)
V	Fluorocarbon / (SK20-2V)

Code	Port Size	Body Part No.
Omit	Cartridge Only	
20T	SAE-20	(B20-2-20T)
20B	1-1/4" BSPG	(B20-2-20B)

Technical Information

General Description

Side to Nose Style Check Valve. For additional information see Technical Tips on pages CV1-CV4.



Features

- Hardened, precision ground parts for durability
- Fully guided poppet for smooth operation
- Size to nose design for ease in manifold design
- All external parts zinc plated

Performance Curve

Pressure Drop vs. Flow (Through cartridge only)

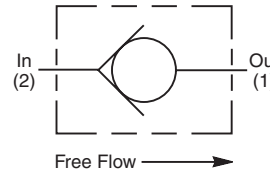
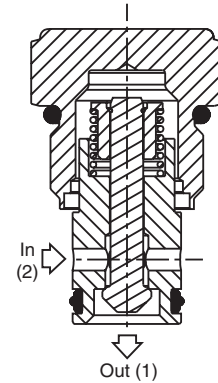
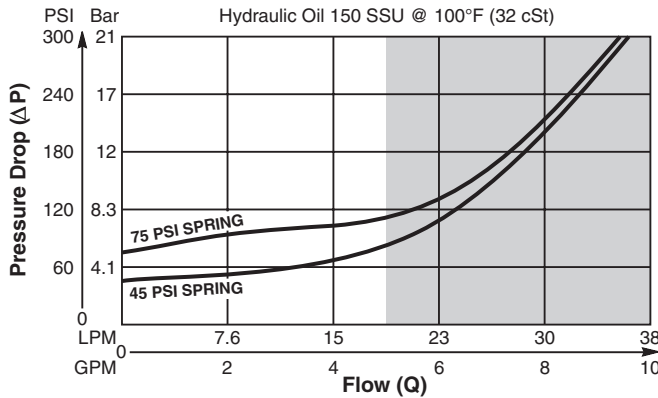

Dimensions

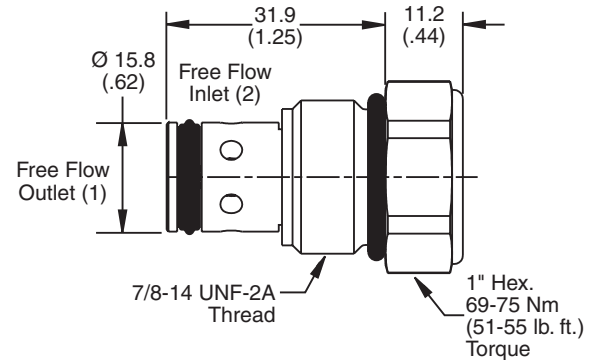

Specifications

Rated Flow	34 LPM (5 GPM)
Maximum Inlet Pressure	350 Bar (5000 PSI)
Leakage at 150 SSU (32 cSt)	2 drops/min. (.13 cc/min.) at 350 Bar (5000 PSI)
Cartridge Material	All parts steel. All operating parts hardened steel.
Operating Temp. Range/Seals	-45°C to +93.3°C ("D"-Ring) (-50°F to +200°F) -31.7°C to +121.1°C (Fluorocarbon) (-25°F to +250°F)
Fluid Compatibility/Viscosity	Mineral-based or synthetic with lubricating properties at viscosities of 45 to 2000 SSU (6 to 420 cSt)
Filtration	ISO code 16/13, SAE Class 4 or better
Approx. Weight	.08 kg (.18 lbs.)
Cavity	C10-2 (See BC Section for more details)
Form Tool	Rougher None Finisher NFT10-2F

Ordering Information

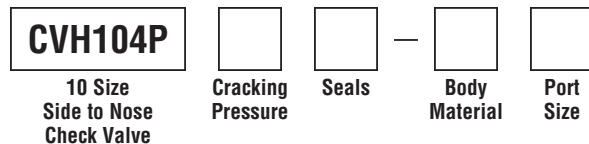

Code	Cracking Pressure	Code	Body Material
Omit	3.1 Bar (45 PSI)	Omit	Steel
75	5.2 Bar (75 PSI)	A	Aluminum

Code	Seals / Kit No.	Code	Port Size	Body Part No.
Omit	"D"-Ring / (SK10-2)	Omit	Cartridge Only	
N	Nitrile / (SK10-2N)	4P	1/4" NPTF	(B10-2-*4P)
V	Fluorocarbon / (SK10-2V)	6P	3/8" NPTF	(B10-2-*6P)
		8P	1/2" NPTF	(B10-2-*8P)
		T8P	1/2" NPTF	(B10-2-T8P)†
		6T	SAE-6	(B10-2-*6T)
		8T	SAE-8	(B10-2-*8T)
		T8T	SAE-8	(B10-2-T8T)†
		6B	3/8" BSPG	(B10-2-6B)†

* Add "A" for aluminum, omit for steel.
† Steel body only.

CV
Check Valves
SH
Shuttle Valves
LM
Load/Motor Controls
FC
Flow Controls
PC
Pressure Controls
LE
Logic Elements
DC
Directional Controls
MV
Manual Valves
SV
Solenoid Valves
PV
Proportional Valves
CE
Coils & Electronics
BC
Bodies & Cavities
TD
Technical Data

Technical Information

- CV Check Valves
- SH Shuttle Valves
- LM Load/Motor Controls
- FC Flow Controls
- PC Pressure Controls
- LE Logic Elements
- DC Directional Controls
- MV Manual Valves
- SV Solenoid Valves
- PV Proportional Valves
- CE Coils & Electronics
- BC Bodies & Cavities
- TD Technical Data

General Description

Poppet Type Check Valve. For additional information see Technical Tips on pages CV1-CV4.

Features

- High flow capacity
- Poppet type construction for minimal leakage - less than 3 drops/min.
- Hardened poppet for maximum durability
- Good contamination tolerance
- All external parts zinc plated

Performance Curve

Pressure Drop vs. Flow (Through cartridge only)

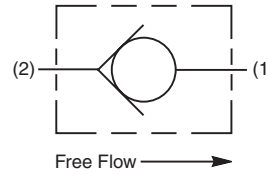
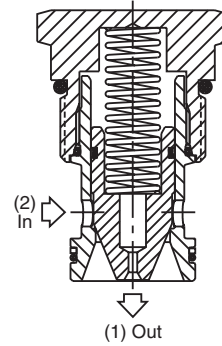
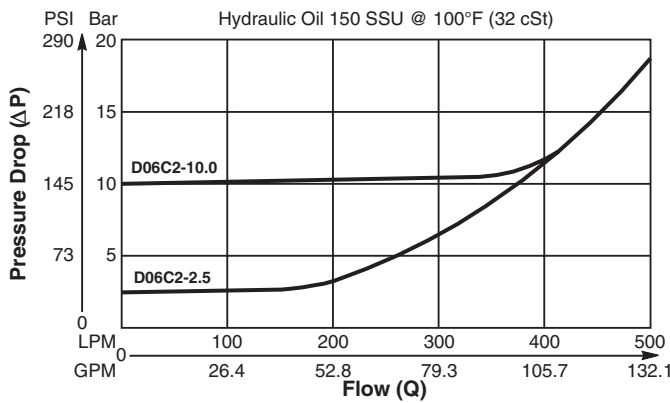

Dimensions Millimeters (Inches)

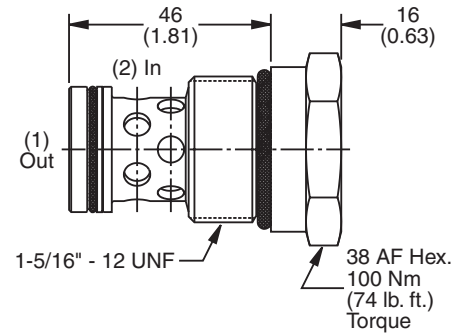

Specifications

Rated Flow	500 LPM (132 GPM)
Nominal Flow @ 7 Bar (100 PSI)	300 LPM (79 GPM)
Maximum Inlet Pressure	420 Bar (6000 PSI)
Leakage at 150 SSU (32 cSt)	Less than 3 drops/min.
Cartridge Material	Steel operating parts, hardened steel poppet.
Operating Temp. Range/Seals	-40°C to +93.3°C (Nitrile, Buna-N) (-40°F to +200°F) -31.7°C to +121.1°C (Fluorocarbon) (-25°F to +250°F)
Fluid Compatibility/Viscosity	Mineral-based or synthetic with lubricating properties at viscosities of 45 to 2000 SSU (6 to 420 cSt)
Filtration	ISO code 16/13, SAE Class 4 or better
Approx. Weight	.26 kg (.57 lbs.)
Cavity	C16-2 (See BC Section for more details)

Ordering Information

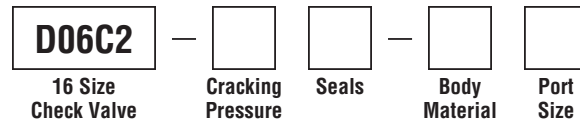

Code	Cracking Pressure
2.5	2.5 Bar (36 PSI) Std.
3.4	3.4 Bar (50 PSI)
6.9	6.9 Bar (100 PSI)
10.0	10.0 Bar (145 PSI)

Code	Body Material
Omit	Steel
A	Aluminum

Code	Seals / Kit No.
N	Nitrile, Buna-N / (SK30514N-1)
V	Fluorocarbon / (SK30514V-1)

Code	Port Size	Body Part No.
Omit	Cartridge Only	
12P	3/4" NPTF	(B16-2-*12P)
16P	1" NPTF	(B16-2-*16P)
8T	SAE-8	(B16-2-*8T)
12T	SAE-12	(B16-2-*12T)
16T	SAE-16	(B16-2-*16T)
12B	3/4" BSPG	(B16-2-12B)†
16B	1" BSPG	(B16-2-*16B)

* Add "A" for aluminum, omit for steel.
† Steel body only.

Technical Information

General Description

Cartridge Style Pilot Operated Check Valve. For additional information see Technical Tips on pages CV1-CV4.

Features

- Hardened, precision ground parts for durability
- Internal pilot position simplifies manifold design
- All external parts zinc plated

Performance Curve

Pressure Drop vs. Flow (Through cartridge only)

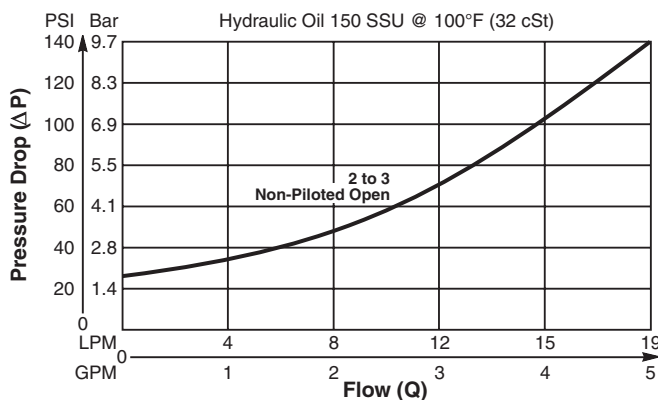

Specifications

Rated Flow	19 LPM (5 GPM)
Maximum Inlet Pressure	207 Bar (3000 PSI)
Leakage at 150 SSU (32 cSt)	5 drops/min. (.33 cc/min.) at 207 Bar (3000 PSI)
Pilot Ratio	3:1
Cartridge Material	All parts steel. All operating parts hardened steel.
Operating Temp. Range/Seals	-40°C to +93.3°C (Nitrile) (-40°F to +200°F) -31.7°C to +121.1°C (Fluorocarbon) (-25°F to +250°F)
Fluid Compatibility/Viscosity	Mineral-based or synthetic with lubricating properties at viscosities of 45 to 2000 SSU (6 to 420 cSt)
Filtration	ISO code 16/13, SAE Class 4 or better
Approx. Weight	.05 kg (.11 lbs.)
Cavity	C08-3 (See BC Section for more details)
Form Tool	Rougher NFT08-3R Finisher NFT08-3F

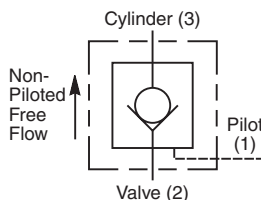
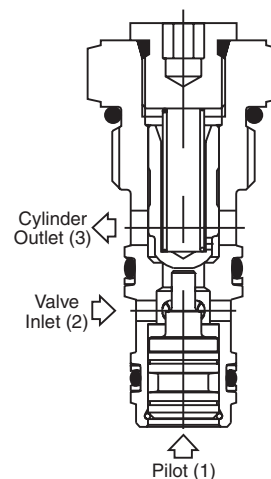
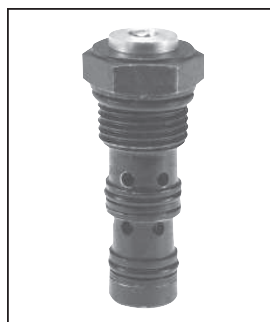

Dimensions Millimeters (Inches)

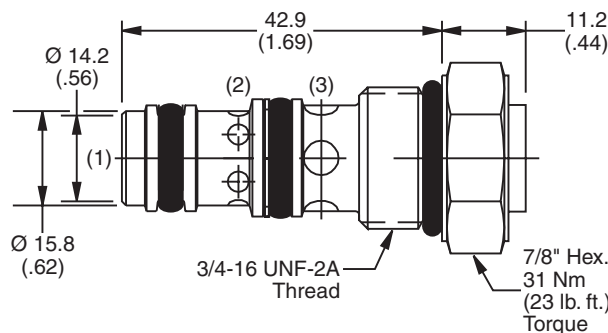

Ordering Information

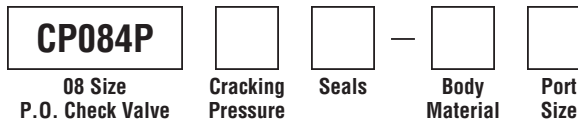

Code	Cracking Pressure
Omit	1.7 Bar (25 PSI)
85	5.9 Bar (85 PSI)

Code	Body Material
Omit	Steel
A	Aluminum

Code	Seals / Kit No.
Omit	Nitrile / (SK08-3N)
V	Fluorocarbon / (SK08-3V)

Code	Port Size	Body Part No.
Omit	Cartridge Only	
4P	1/4" NPTF	(B08-3-*4P)
4T	SAE-4	(B08-3-*4T)
6T	SAE-6	(B08-3-*6T)
6B	3/8" BSPG	(B08-3-*6B)

* Add "A" for aluminum, omit for steel.

CV
Check Valves

SH
Shuttle Valves

LM
Load/Motor Controls

FC
Flow Controls

PC
Pressure Controls

LE
Logic Elements

DC
Directional Controls

MV
Manual Valves

SV
Solenoid Valves

PV
Proportional Valves

CE
Coils & Electronics

BC
Bodies & Cavities

TD
Technical Data

Technical Information

- CV Check Valves
- SH Shuttle Valves
- LM Load/Motor Controls
- FC Flow Controls
- PC Pressure Controls
- LE Logic Elements
- DC Directional Controls
- MV Manual Valves
- SV Solenoid Valves
- PV Proportional Valves
- CE Coils & Electronics
- BC Bodies & Cavities
- TD Technical Data

General Description

Cartridge Style Pilot Operated Check Valve. For additional information see Technical Tips on pages CV1-CV4.



Features

- Hardened, precision ground parts for durability
- Internal pilot position simplifies manifold design
- All external parts have yellow zinc dichromate. This coating is ideal for salt spray applications.

Performance Curve

Pressure Drop vs. Flow (Through cartridge only)

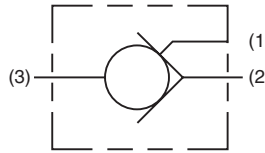
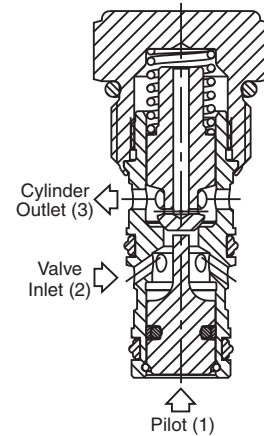
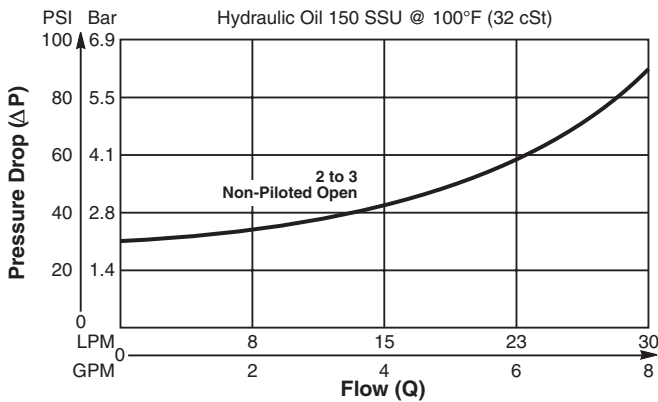

Dimensions Millimeters (Inches)

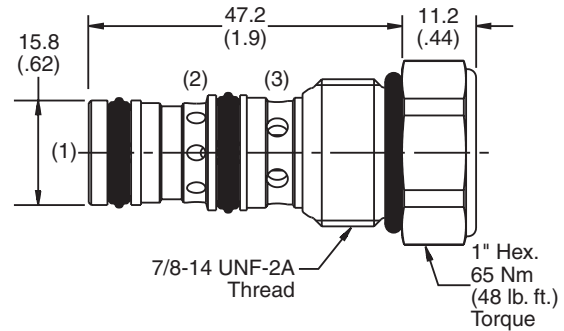

Specifications

Rated Flow	30 LPM (8 GPM)
Maximum Inlet Pressure	350 Bar (5000 PSI)
Leakage at 150 SSU (32 cSt)	2 drops/min. (0.13 cc/min.) at 350 Bar (5000 PSI)
Pilot Ratio	4:1
Cartridge Material	All parts steel. All operating parts hardened steel.
Operating Temp. Range/Seals	-45°C to +93.3°C ("D"-Ring) (-50°F to +200°F) -31.7°C to +121.1°C (Fluorocarbon) (-25°F to +250°F)
Fluid Compatibility/Viscosity	Mineral-based or synthetic with lubricating properties at viscosities of 45 to 2000 SSU (6 to 420 cSt)
Filtration	ISO code 16/13, SAE Class 4 or better
Approx. Weight	.09 kg (0.2 lbs.)
Cavity	C10-3 (See BC Section for more details)
Form Tool	Rougher NFT10-3R Finisher NFT10-3F

Ordering Information

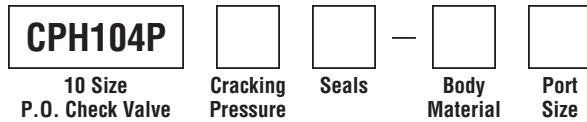

Code	Cracking Pressure
15	1.0 Bar (15 PSI)
Omit	2.1 Bar (31 PSI)
50	3.5 Bar (50 PSI)

Code	Body Material
Omit	Steel
A	Aluminum

Code	Seals / Kit No.
Omit	"D"-Ring / (SK10-3)
N	Nitrile / (SK10-3N)
V	Fluorocarbon / (SK10-3V)

Code	Port Size	Body Part No.
Omit	Cartridge Only	
4P	1/4" NPTF	(B10-3-*4P)
6P	3/8" NPTF	(B10-3-*6P)
8P	1/2" NPTF	(B10-3-*8P)
6T	SAE-6	(B10-3-*6T)
8T	SAE-8	(B10-3-*8T)
6B	3/8" BSPG	(B10-3-6B)†
8B	1/2" BSPG	(B10-3-*8B)

* Add "A" for aluminum, omit for steel.
† Steel body only.



Technical Information

General Description

Cartridge Style Pilot Operated Check Valve. For additional information see Technical Tips on pages CV1-CV4.

Features

- Hardened, precision ground parts for durability
- Internal pilot position simplifies manifold design
- All external parts have yellow zinc dichromate. This coating is ideal for salt spray applications.

Performance Curve

Pressure Drop vs. Flow (Through cartridge only)

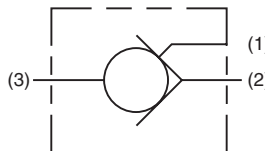
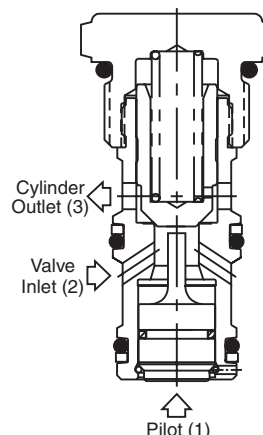
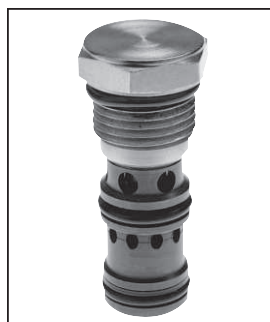
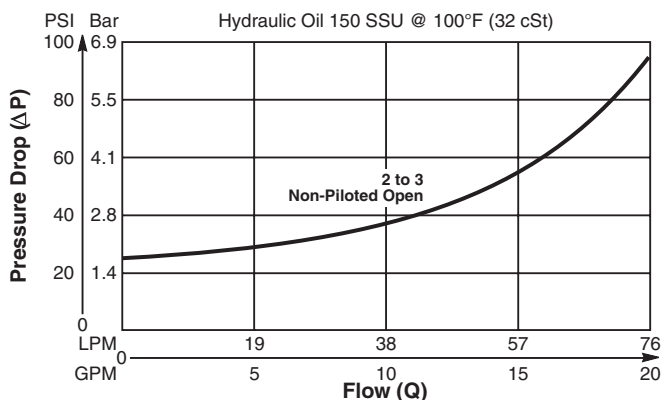

Dimensions Millimeters (Inches)

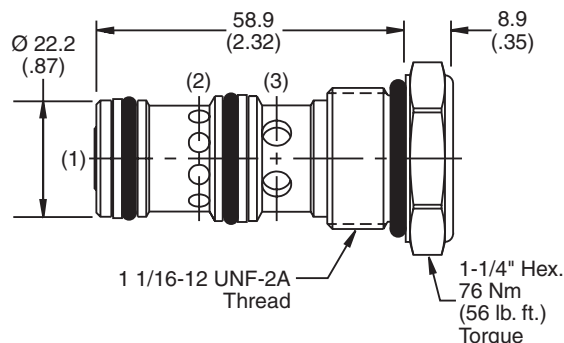

Specifications

Rated Flow	75 LPM (20 GPM)
Maximum Inlet Pressure	350 Bar (5000 PSI)
Leakage at 150 SSU (32 cSt)	5 drops/min. (.33 cc/min.) at 350 Bar (5000 PSI)
Pilot Ratio	3:1
Cartridge Material	All parts steel. All operating parts hardened steel.
Operating Temp. Range/Seals	-40°C to +93.3°C (Nitrile) (-40°F to +200°F) -31.7°C to +121.1°C (Fluorocarbon) (-25°F to +250°F)
Fluid Compatibility/Viscosity	Mineral-based or synthetic with lubricating properties at viscosities of 45 to 2000 SSU (6 to 420 cSt)
Filtration	ISO code 16/13, SAE Class 4 or better
Approx. Weight	0.2 kg (.44 lbs.)
Cavity	C12-3 (See BC Section for more details)
Form Tool	Rougher NFT12-3R Finisher NFT12-3F

Ordering Information

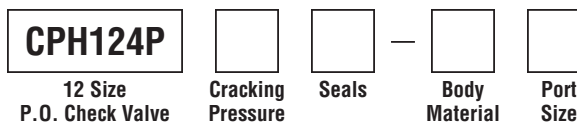

Code	Cracking Pressure
Omit	1.7 Bar (25 PSI)

Code	Body Material
Omit	Steel
A	Aluminum

Code	Seals / Kit No.
Omit	Nitrile / (SK12-3)
V	Fluorocarbon / (SK12-3V)

Code	Port Size	Body Part No.
Omit	Cartridge Only	
8T	SAE-8	(B12-3-*8T)
12T	SAE-12	(B12-3-*12T)
8B	1/2" BSPG	(B12-3-8B)†

* Add "A" for aluminum, omit for steel.
† Steel body only.

Technical Information

- CV** Check Valves
- SH** Shuttle Valves
- LM** Load/Motor Controls
- FC** Flow Controls
- PC** Pressure Controls
- LE** Logic Elements
- DC** Directional Controls
- MV** Manual Valves
- SV** Solenoid Valves
- PV** Proportional Valves
- CE** Coils & Electronics
- BC** Bodies & Cavities
- TD** Technical Data

General Description

Pilot Piston Style Pilot Operated Check Valve. For additional information see Technical Tips on pages CV1-CV4.

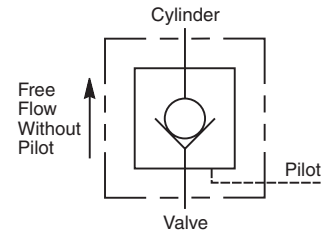
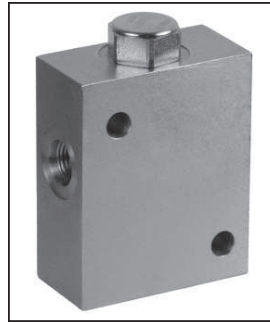

Features

- Spherical poppet for low leakage
- “D”-Ring eliminates back-up rings
- Optional sealed pilot piston

Specifications

Maximum Flow	56 LPM (15 GPM)
Maximum Inlet Pressure	210 Bar (3000 PSI) - CSP081 350 Bar (5000 PSI) - CSPH081
Leakage Across Check 150 SSU (32 cSt)	2 drops/min. (.13 cc/min.)
Leakage Across Pilot Piston (No Seals)	312 cc/min 0.3 LPM (.08 GPM)
Pilot Ratio	4:1
Pilot Piston Part Numbers	No Seal - 718237 Nitrile Seal - 718237N Fluorocarbon Seal - 718237V
Cartridge Material	All parts steel. All operating parts hardened steel.
Body Material	Aluminum - CSP081 Steel - CSPH081
Operating Temp. Range (Ambient)	-45°C to +93.3°C (“D”-Ring) (-50°F to +200°F) -31.7°C to +121.1°C (Fluorocarbon) (-25°F to +250°F)
Filtration	ISO code 16/13, SAE Class 4 or better
Fluids	Mineral-based or synthetic with lubricating properties at viscosities of 45 to 2000 SSU (6 to 420 cSt)
Approx. Weight	

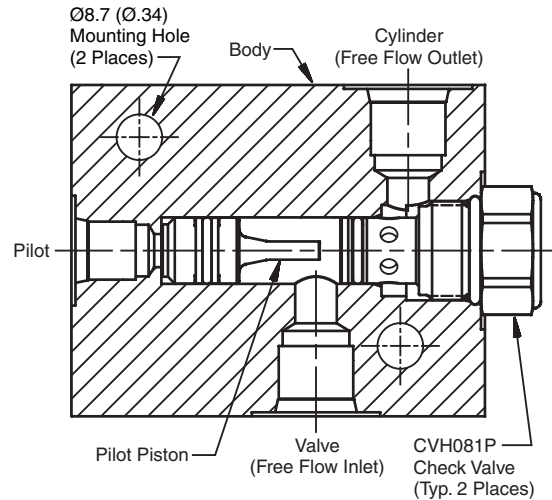

Performance Curve

Pressure Drop vs. Flow (Through cartridge only)

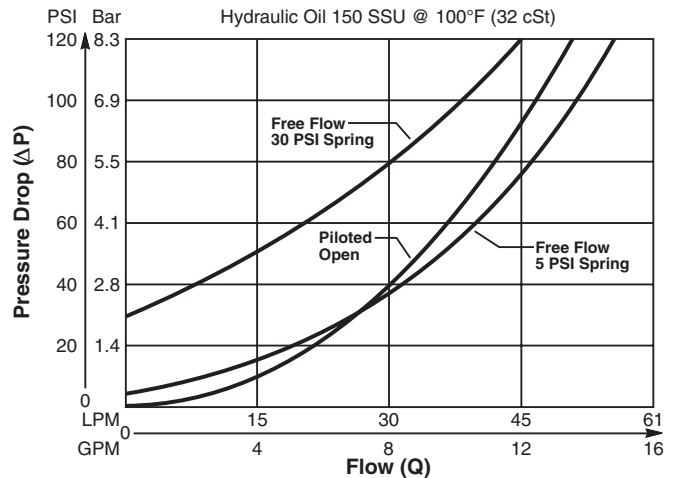

Dimensions Millimeters (Inches)

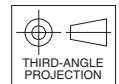
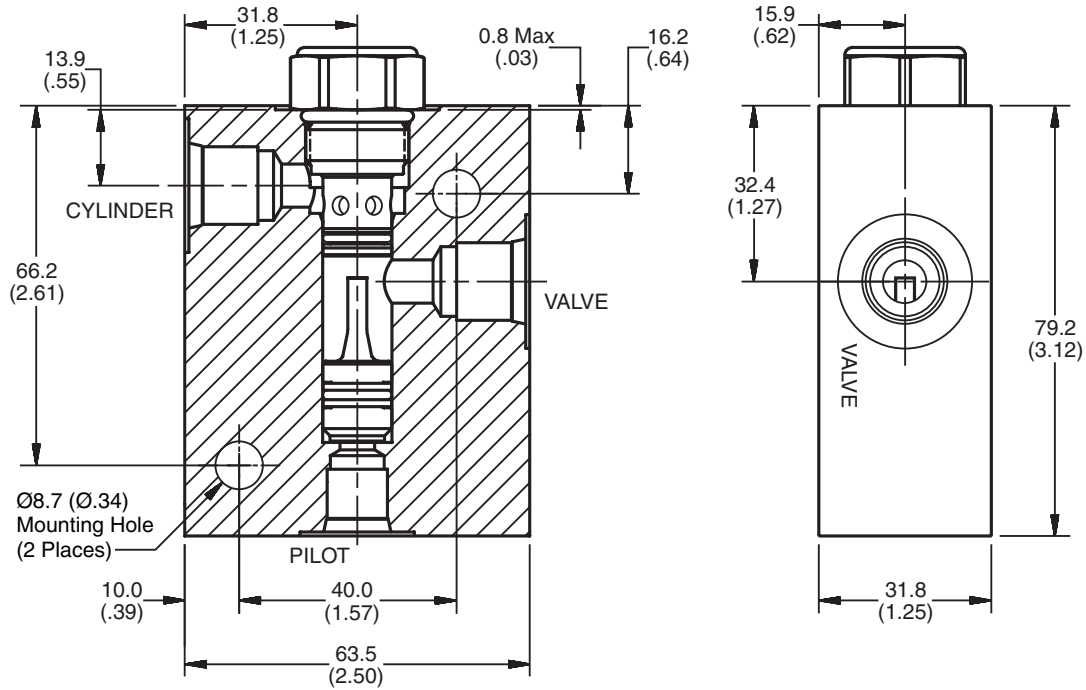

Ordering Information

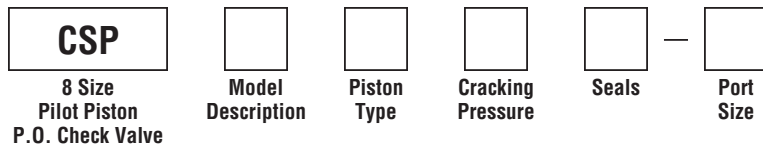

Code	Model Description
081	3000 PSI Series
H081	5000 PSI Series

Code	Cracking Pressure
*Omit	0.3 Bar (5 PSI)
10	0.7 Bar (10 PSI)
30	2.1 Bar (30 PSI)
65	4.5 Bar (65 PSI)
100	6.9 Bar (100 PSI)
150	10.4 Bar (150 PSI)

Code	Seals / Kit No.
Omit	"D"-Ring / (SK08-2)
N	Nitrile / (SK08-2N)
V	Fluorocarbon / (SK08-2V)

Code	Port Size	Material
Omit	Cartridge Only	
A6T	SAE-6	Aluminum (CSP081 Only)
6T	SAE-6	Steel (CSPH081 Only)

Code	Piston Type
P	Pilot Piston without seal
A	Pilot Piston with seal Note: Requires 1.4 Bar (20 PSI) crack minimum.

*Not available with "A" option.

Technical Information

- CV Check Valves
- SH Shuttle Valves
- LM Load/Motor Controls
- FC Flow Controls
- PC Pressure Controls
- LE Logic Elements
- DC Directional Controls
- MV Manual Valves
- SV Solenoid Valves
- PV Proportional Valves
- CE Coils & Electronics
- BC Bodies & Cavities
- TD Technical Data

General Description

Pilot Piston Style Pilot Operated Check Valve. For additional information see Technical Tips on pages CV1-CV4.

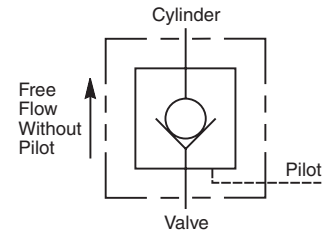
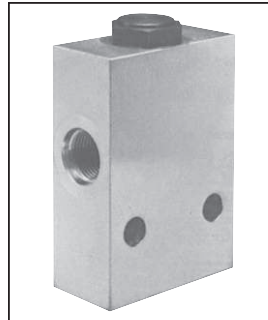

Features

- Spherical poppet for low leakage
- “D”-Ring eliminates back-up rings
- Optional sealed pilot piston
- Steel or aluminum body construction

Specifications

Maximum Flow	56 LPM (15 GPM)
Maximum Inlet Pressure	210 Bar (3000 PSI) - CSP103 350 Bar (5000 PSI) - CSPH103
Leakage Across Check 150 SSU (32 cSt)	2 drops/min. (.13 cc/min.)
Leakage Across Pilot Piston (No Seals)	312 cc/min 0.3 LPM (.08 GPM)
Pilot Ratio	4:1
Pilot Piston Part Numbers	No Seal - 717909 Nitrile Seal - 717909N Fluorocarbon Seal - 717909V
Cartridge Material	All parts steel. All operating parts hardened steel.
Body Material	Aluminum - CSP103 Steel - CSPH103
Operating Temp. Range (Ambient)	-45°C to +93.3°C (“D”-Ring) (-50°F to +200°F) -31.7°C to +121.1°C (Fluorocarbon) (-25°F to +250°F)
Filtration	ISO code 16/13, SAE Class 4 or better
Fluids	Mineral-based or synthetic with lubricating properties at viscosities of 45 to 2000 SSU (6 to 420 cSt)
Approx. Weight	

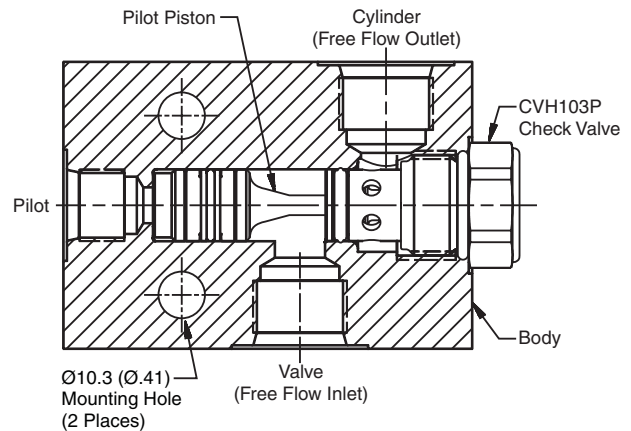

Performance Curve

Pressure Drop vs. Flow (Through cartridge only)

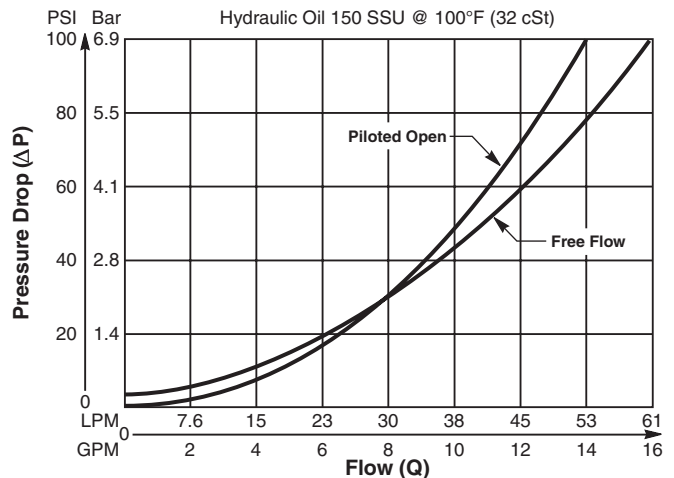

Technical Information

Dimensions Millimeters (Inches)

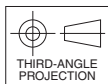
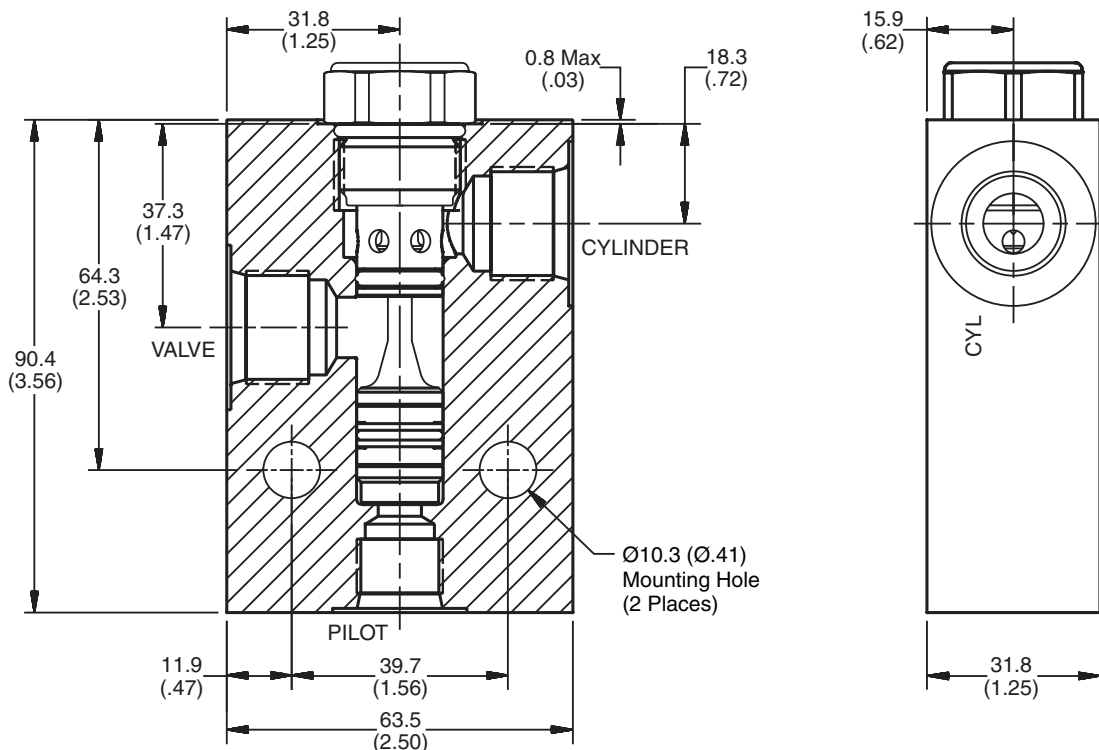

Ordering Information

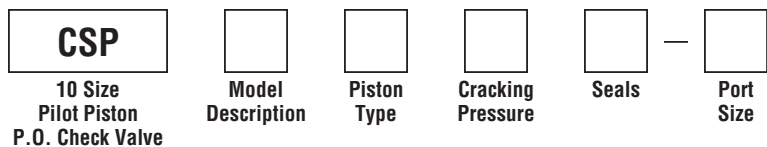

Code	Model Description
103	3000 PSI Series
H103	5000 PSI Series

Code	Cracking Pressure
*Omit	0.3 Bar (5 PSI)
20	1.4 Bar (20 PSI)
50	3.5 Bar (50 PSI)
65	4.5 Bar (65 PSI)
80	5.5 Bar (80 PSI)
100	6.9 Bar (100 PSI)

Code	Seals / Kit No.
Omit	"D"-Ring / (SK10-2)
N	Nitrile / (SK10-2N)
V	Fluorocarbon / (SK10-2V)

Code	Port Size	Material
Omit	Cartridge Only	
A8T	SAE-8	Aluminum (CSP103 Only)
8T	SAE-8	Steel (CSPH103 Only)

Code	Piston Type
P	Pilot Piston without seal
A	Pilot Piston with seal Note: Requires 1.4 Bar (20 PSI) crack minimum.

*Not available with "A" option.

- CV Check Valves
- SH Shuttle Valves
- LM Load/Motor Controls
- FC Flow Controls
- PC Pressure Controls
- LE Logic Elements
- DC Directional Controls
- MV Manual Valves
- SV Solenoid Valves
- PV Proportional Valves
- CE Coils & Electronics
- BC Bodies & Cavities
- TD Technical Data

Technical Information

- CV** Check Valves
- SH** Shuttle Valves
- LM** Load/Motor Controls
- FC** Flow Controls
- PC** Pressure Controls
- LE** Logic Elements
- DC** Directional Controls
- MV** Manual Valves
- SV** Solenoid Valves
- PV** Proportional Valves
- CE** Coils & Electronics
- BC** Bodies & Cavities
- TD** Technical Data

General Description

Pilot Piston Style Pilot Operated Check Valve. For additional information see Technical Tips on pages CV1-CV4.

Features

- Hardened precision ground parts for durability
- Optional sealed pilot piston
- Steel or aluminum body construction

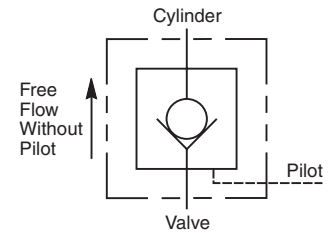
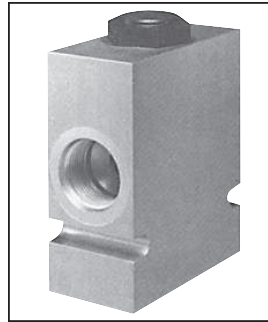

Specifications

Maximum Flow	187 LPM (50 GPM)
Maximum Inlet Pressure	210 Bar (3000 PSI) - CSP161 350 Bar (5000 PSI) - CSPH161
Leakage at 150 SSU (32 cSt)	5 drops/min (.33 cc/min) @ 350 Bar (5000 psi)
Leakage Across Pilot Piston (No Seals)	312 cc/min 0.3 LPM (.08 GPM)
Pilot Ratio	3:1
Pilot Piston Part Numbers	No Seal - 717910 Nitrile Seal - 717910N Fluorocarbon - 717910V
Cartridge Material	All parts steel. All operating parts hardened steel.
Body Material	Aluminum - CSP161 Steel - CSPH161
Operating Temp. Range (Ambient)	-40°C to +93.3°C (Nitrile) (-40°F to +200°F) -31.7°C to +121.1°C (Fluorocarbon) (-25°F to +250°F)
Filtration	ISO code 16/13, SAE Class 4 or better
Fluids	Mineral-based or synthetic with lubricating properties at viscosities of 45 to 2000 SSU (6 to 420 cSt)
Approx. Weight	

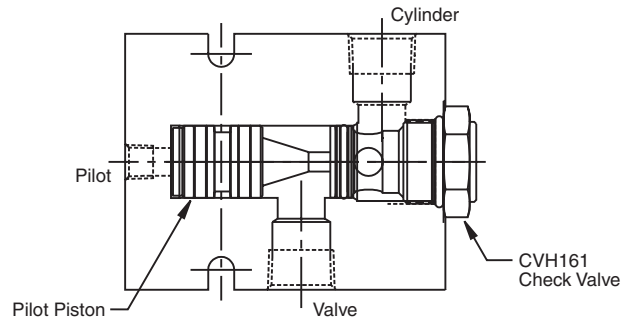

Performance Curve

Pressure Drop vs. Flow (Through cartridge only)

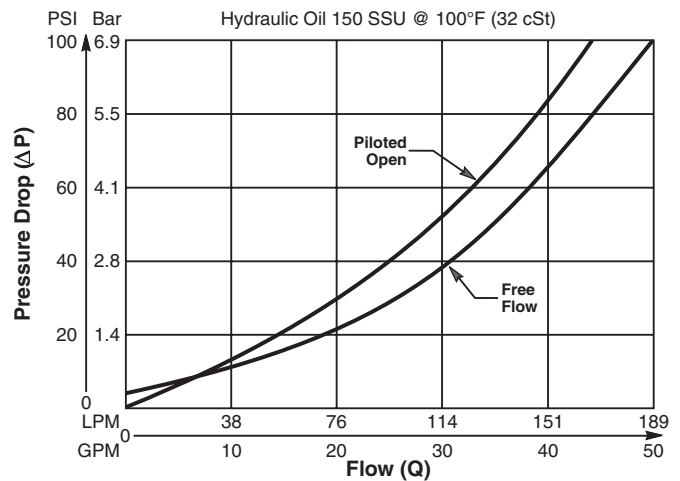

Technical Information

Dimensions Millimeters (Inches)

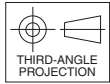
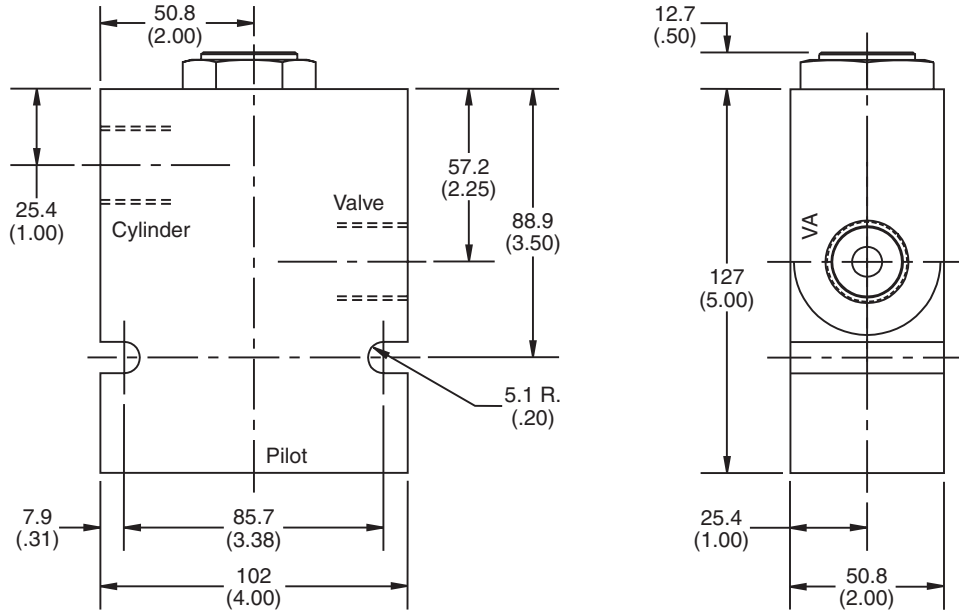

Ordering Information

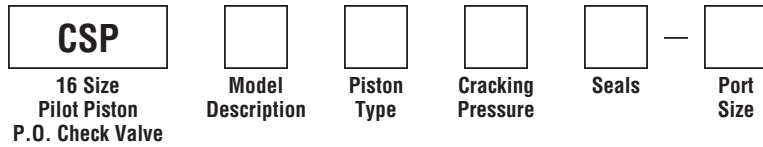

Code	Model Description
161	3000 PSI Series
H161	5000 PSI Series

Code	Cracking Pressure
*Omit	0.3 Bar (5 PSI)
20	1.4 Bar (20 PSI)
65	4.5 Bar (65 PSI)
175	12.1 Bar (175 PSI)

Code	Seals / Kit No.
Omit	Nitrile / (SK16-2N)
V	Fluorocarbon / (SK16-2V)

Code	Port Size	Material
Omit	Cartridge Only	
A16T	SAE-16	Aluminum (CSP161 Only)
16T	SAE-16	Steel (CSPH161 Only)

Code	Piston Type
P	Pilot Piston without seal
A	Pilot Piston with seal Note: Requires 1.4 Bar (20 PSI) crack minimum.

*Not available with "A" option.

- CV
Check Valves
- SH
Shuttle Valves
- LM
Load/Motor Controls
- FC
Flow Controls
- PC
Pressure Controls
- LE
Logic Elements
- DC
Directional Controls
- MV
Manual Valves
- SV
Solenoid Valves
- PV
Proportional Valves
- CE
Coils & Electronics
- BC
Bodies & Cavities
- TD
Technical Data

Technical Information

- CV Check Valves
- SH Shuttle Valves
- LM Load/Motor Controls
- FC Flow Controls
- PC Pressure Controls
- LE Logic Elements
- DC Directional Controls
- MV Manual Valves
- SV Solenoid Valves
- PV Proportional Valves
- CE Coils & Electronics
- BC Bodies & Cavities
- TD Technical Data

General Description

Miniature Pilot to Open, Poppet Type Check Valve. For additional information see Technical Tips on pages CV1-CV4.

Features

- Hardened poppet for maximum durability
- Low leakage - less than 3 drops/min.
- Sealed pilot
- Extremely compact construction - can be fitted directly into most cylinders
- Cavity commonality with load control valves
- Dual line blocks available
- All external parts zinc plated

Performance Curve

Pressure Drop vs. Flow (Through cartridge only)

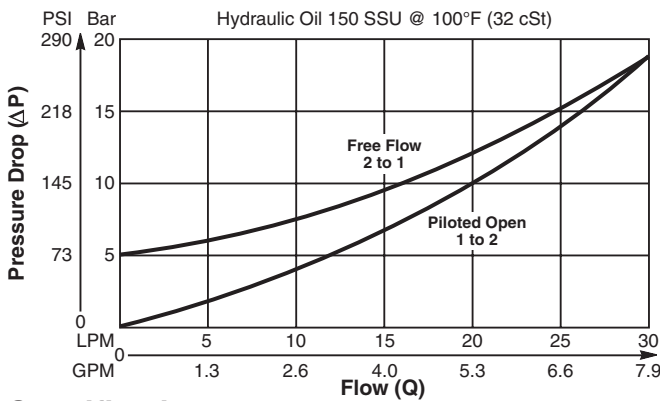

Specifications

Rated Flow	30 LPM (8 GPM)
Nominal Flow @ 7 Bar (100 PSI)	16 LPM (4.2 GPM) (Piloted Open)
Maximum Inlet Pressure	420 Bar (6000 PSI)
Leakage at 150 SSU (32 cSt)	Less than 3 drops/min.
Cracking Pressure	5 Bar (72 PSI)
Pilot Ratio	4:1
Cartridge Material	Steel operating parts, hardened steel poppet.
Operating Temp. Range/Seals	-40°C to +93.3°C (Nitrile, Buna-N) (-40°F to +200°F) -31.7°C to +121.1°C (Fluorocarbon) (-25°F to +250°F)
Fluid Compatibility/Viscosity	Mineral-based or synthetic with lubricating properties at viscosities of 45 to 2000 SSU (6 to 420 cSt)
Filtration	ISO code 16/13, SAE Class 4 or better
Approx. Weight	.066 kg (.145 lbs.)
Cavity	53-1 (See BC Section for more details)

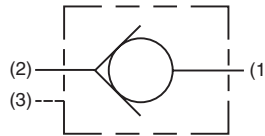
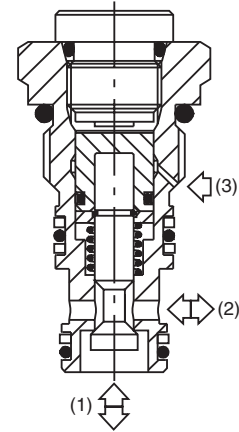
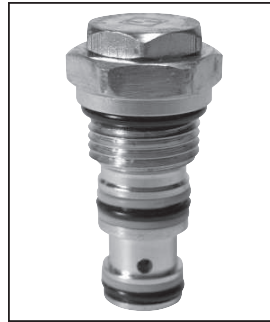

Dimensions Millimeters (Inches)

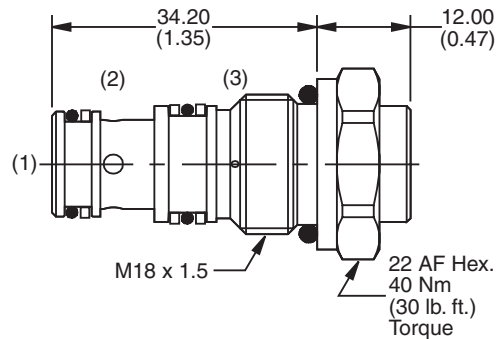

Ordering Information

D4A020 **Seals**
Check Valve

Code	Seals / Kit No.
N	Nitrile, Buna-N / (SK30090N-1)
V	Fluorocarbon / (SK30090V-1)

Order Bodies Separately

LB10
Line Body Porting Body Material

Code	Porting
310	3/8" BSP (Main) 1/4" BSP (Aux.)
318	3/8" SAE (Main) 1/4" SAE (Aux.)
312	3/8" BSP Dual Cavity
319	3/8" SAE Dual Cavity

Code	Body Material
A	Aluminum
S	Steel

Technical Information

General Description

Pilot to Open, Poppet Type Check Valve. For additional information see Technical Tips on pages CV1-CV4.

Features

- Hardened poppet for maximum durability
- High flow capacity
- Low leakage - less than 3 drops/min.
- Sealed pilot
- Good contamination tolerance
- Cavity commonality with load control valves
- Dual line blocks available
- All external parts zinc plated

Performance Curve

Pressure Drop vs. Flow (Through cartridge only)

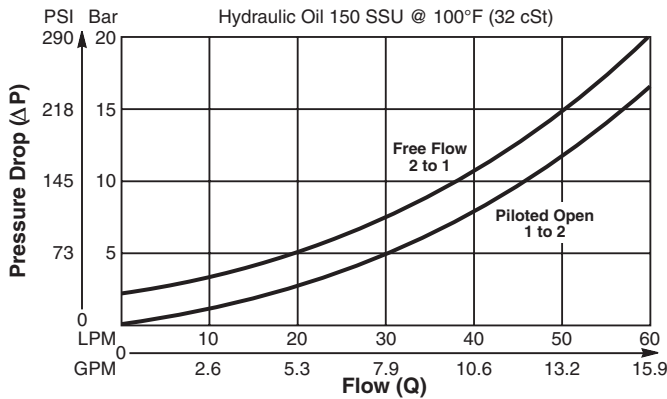

Specifications

Rated Flow	60 LPM (16 GPM)
Nominal Flow @ 7 Bar (100 PSI)	32 LPM (8.5 GPM) (Pilot Open)
Maximum Inlet Pressure	420 Bar (6000 PSI)
Leakage at 150 SSU (32 cSt)	Less than 3 drops/min.
Cracking Pressure	3 Bar (43.5 PSI)
Pilot Ratio	4:1
Cartridge Material	Steel operating parts, hardened steel poppet.
Operating Temp. Range/Seals	-40°C to +93.3°C (Nitrile, Buna-N) (-40°F to +200°F) -31.7°C to +121.1°C (Fluorocarbon) (-25°F to +250°F)
Fluid Compatibility/Viscosity	Mineral-based or synthetic with lubricating properties at viscosities of 45 to 2000 SSU (6 to 420 cSt)
Filtration	ISO code 16/13, SAE Class 4 or better
Approx. Weight	.15 kg (.33 lbs.)
Cavity	68-1 (See BC Section for more details)

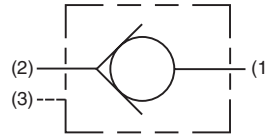
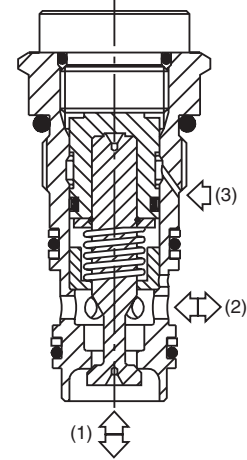

Dimensions Millimeters (Inches)

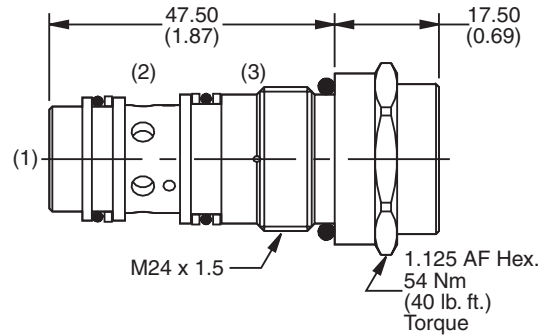

Ordering Information

D4A040 **Seals**
Check Valve

Code	Seals / Kit No.
N	Nitrile, Buna-N / (SK30059N-1)
V	Fluorocarbon / (SK30059V-1)

Order Bodies Separately

LB10
Line Body Porting Body Material

Code	Porting
251	1/2" BSP (Main) 1/4" BSP (Aux.)
253	1/2" SAE (Main) 1/4" SAE (Aux.)
259	1/2" BSP Dual Cavity
261	1/2" SAE Dual Cavity

Code	Body Material
A	Aluminum
S	Steel

CV Check Valves

SH Shuttle Valves

LM Load/Motor Controls

FC Flow Controls

PC Pressure Controls

LE Logic Elements

DC Directional Controls

MV Manual Valves

SV Solenoid Valves

PV Proportional Valves

CE Coils & Electronics

BC Bodies & Cavities

TD Technical Data

Technical Information

- CV Check Valves
- SH Shuttle Valves
- LM Load/Motor Controls
- FC Flow Controls
- PC Pressure Controls
- LE Logic Elements
- DC Directional Controls
- MV Manual Valves
- SV Solenoid Valves
- PV Proportional Valves
- CE Coils & Electronics
- BC Bodies & Cavities
- TD Technical Data

General Description

Pilot to Open, Poppet Type Check Valve. For additional information see Technical Tips on pages CV1-CV4.

Features

- Hardened poppet for maximum durability
- High flow capacity
- Low leakage - less than 3 drops/min.
- Sealed pilot
- Good contamination tolerance
- Cavity commonality with load control valves
- Dual line blocks available
- All external parts zinc plated

Performance Curve

Pressure Drop vs. Flow (Through cartridge only)

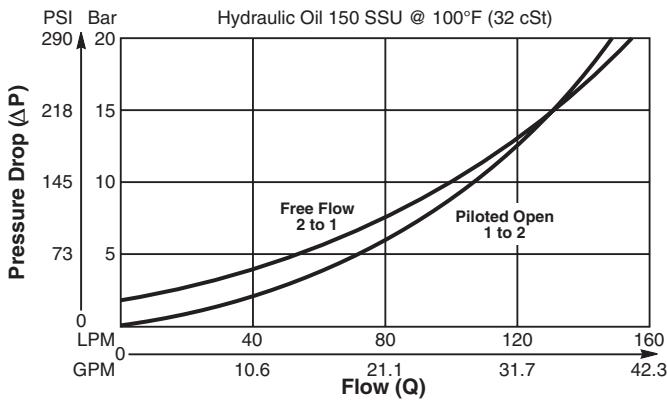

Specifications

Rated Flow	150 LPM (40 GPM)
Nominal Flow @ 7 Bar (100 PSI)	80 LPM (21 GPM) (Piloted Open)
Maximum Inlet Pressure	420 Bar (6000 PSI)
Leakage at 150 SSU (32 cSt)	Less than 3 drops/min.
Cracking Pressure	2 Bar (30 PSI)
Pilot Ratio	4:1
Cartridge Material	Steel operating parts, hardened steel poppet.
Operating Temp. Range/Seals	-40°C to +93.3°C (Nitrile, Buna-N) (-40°F to +200°F) -31.7°C to +121.1°C (Fluorocarbon) (-25°F to +250°F)
Fluid Compatibility/Viscosity	Mineral-based or synthetic with lubricating properties at viscosities of 45 to 2000 SSU (6 to 420 cSt)
Filtration	ISO code 16/13, SAE Class 4 or better
Approx. Weight	.24 kg (.528 lbs.)
Cavity	3C (See BC Section for more details)

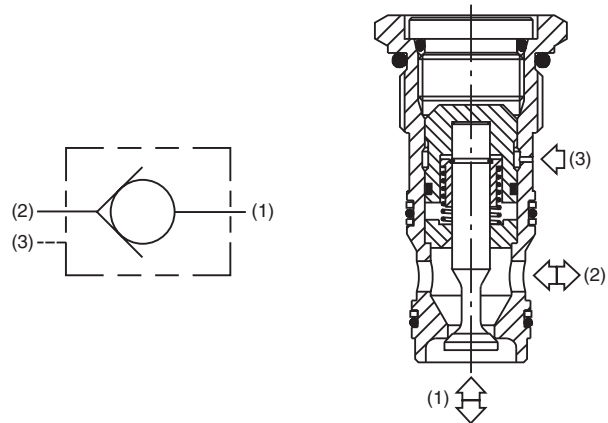

Dimensions Millimeters (Inches)

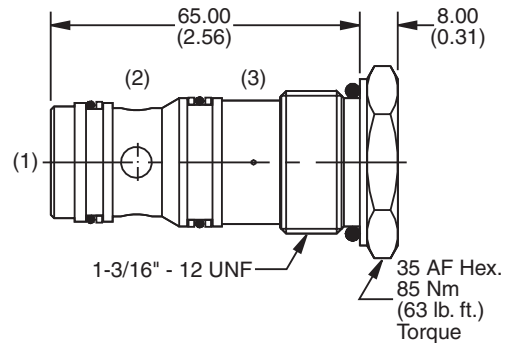

Ordering Information

D3B125 **Seals**
Check Valve

Code	Seals / Kit No.
N	Nitrile, Buna-N / (SK30008N-1)
V	Fluorocarbon / (SK30008V-1)

Order Bodies Separately

LB10
Line Body Porting Body Material

Code	Porting
039	3/4" BSP (Main) 1/4" BSP (Aux.)
069	1" SAE (Main) 1/4" SAE (Aux.)
034	3/4" BSP Dual Cavity
234	3/4" SAE Dual Cavity

Code	Body Material
A	Aluminum
S	Steel

Technical Information

General Description

Pilot to Close Check Valve. For additional information see Technical Tips on pages CV1-CV4.

Features

- Hardened, precision ground parts for durability
- Fully guided poppet for smooth operation
- All external parts zinc plated

Performance Curve

Pressure Drop vs. Flow (Through cartridge only)

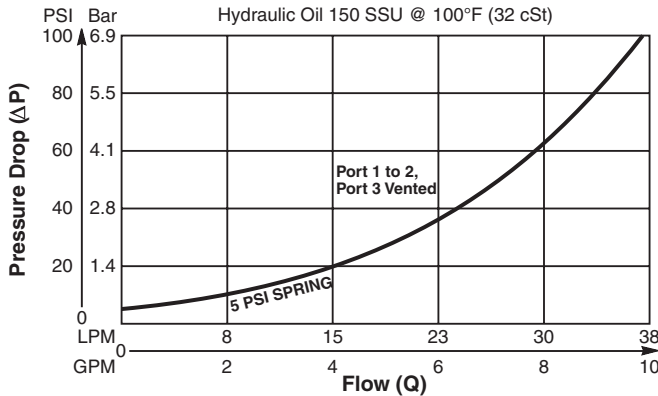

Specifications

Rated Flow	38 LPM (10 GPM)
Maximum Inlet Pressure	240 Bar (3500 PSI)
Leakage at 150 SSU (32 cSt)	15 drops/min. (.99 cc/min.) at 240 Bar (3500 PSI)
Pilot Ratio	2:1
Operating Temp. Range/Seals	-40°C to +93.3°C (Nitrile) (-40°F to +200°F) -31.7°C to +121.1°C (Fluorocarbon) (-25°F to +250°F)
Approx. Weight	.14 kg (0.31 lbs.)
Cavity	C10-3 (See BC Section for more details)
Form Tool	Rougher NFT10-3R Finisher NFT10-3F

Regeneration Circuit

(See Technical Tips Section)

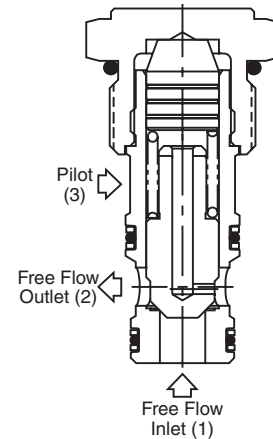
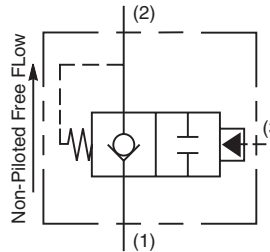
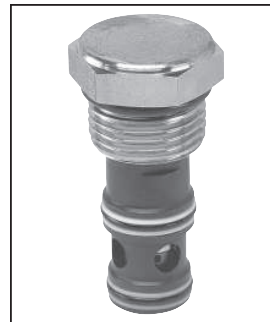
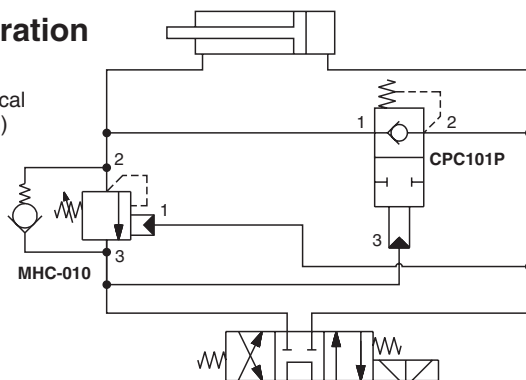

Dimensions Millimeters (Inches)

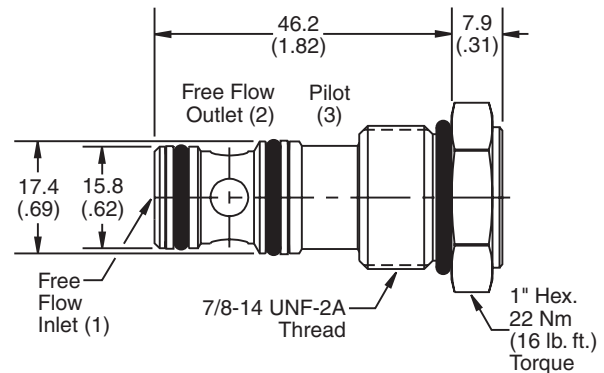

Ordering Information

CPC101P				
10 Size	Cracking Pressure	Seals	Body Material	Port Size
Omit	0.3 Bar (5 PSI)			
50	3.5 Bar (50 PSI)			

Code	Cracking Pressure	Code	Body Material
Omit	0.3 Bar (5 PSI)	Omit	Steel
50	3.5 Bar (50 PSI)	A	Aluminum

Code	Seals / Kit No.	Code	Port Size	Body Part No.
Omit	Nitrile / (SK10-3)	Omit	Cartridge Only	
V	Fluorocarbon / (SK10-3V)	4P	1/4" NPTF	(B10-3-*4P)
		6P	3/8" NPTF	(B10-3-*6P)
		8P	1/2" NPTF	(B10-3-*8P)
		6T	SAE-6	(B10-3-*6T)
		8T	SAE-8	(B10-3-*8T)
		6B	3/8" BSPG	(B10-3-6B)†
		8B	1/2" BSPG	(B10-3-*8B)

* Add "A" for aluminum, omit for steel.
† Steel body only.



- CV**
Check Valves
- SH**
Shuttle Valves
- LM**
Load/Motor Controls
- FC**
Flow Controls
- PC**
Pressure Controls
- LE**
Logic Elements
- DC**
Directional Controls
- MV**
Manual Valves
- SV**
Solenoid Valves
- PV**
Proportional Valves
- CE**
Coils & Electronics
- BC**
Bodies & Cavities
- TD**
Technical Data

General Description

Cartridge Style Dual Pilot Operated Check Valve. For additional information see Technical Tips on pages CV1-CV4.

Features

- Hardened, precision ground parts for durability
- Cost effective-replaces two cartridges
- Internal pilot position
- Common cavity
- All external parts zinc plated

Performance Curve

Pressure Drop vs. Flow (Through cartridge only)

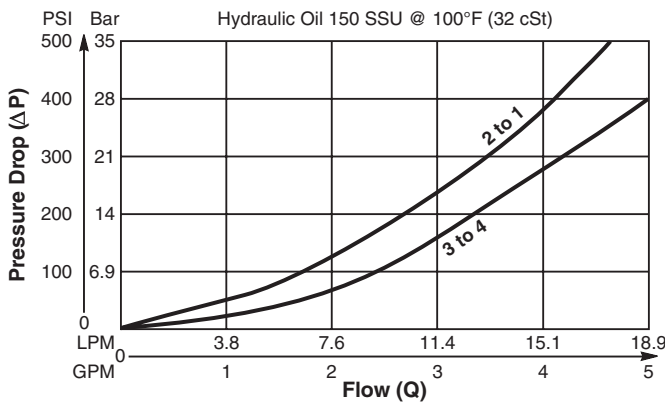

Specifications

Rated Flow	19 LPM (5 GPM)
Maximum Inlet Pressure	207 Bar (3000 PSI)
Leakage at 150 SSU (32 cSt)	5 drops/min. (.33 cc/min.) at 207 Bar (3000 PSI)
Pilot Ratio	3:1
Cartridge Material	All parts steel. All operating parts hardened steel.
Operating Temp. Range/Seals	-40°C to +93.3°C (Nitrile) (-40°F to +200°F) -31.7°C to +121.1°C (Fluorocarbon) (-25°F to +250°F)
Fluid Compatibility/Viscosity	Mineral-based or synthetic with lubricating properties at viscosities of 45 to 2000 SSU (6 to 420 cSt)
Filtration	ISO code 16/13, SAE Class 4 or better
Approx. Weight	.05 kg (.11 lbs.)
Cavity	C08-4 (See BC Section for more details)
Form Tool	Rougher NFT08-4R Finisher NFT08-4F

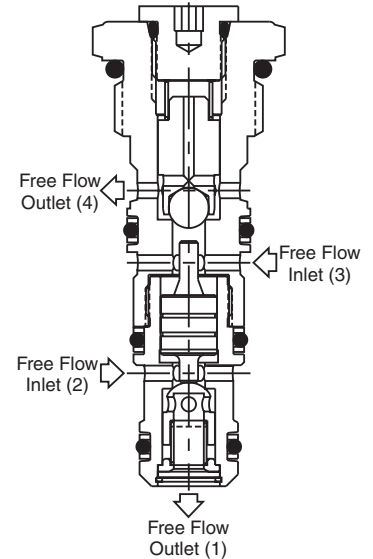
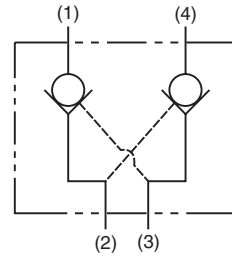
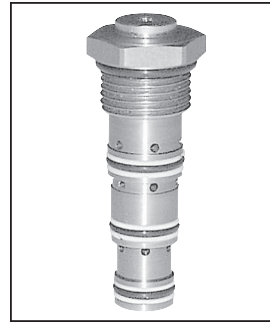

Dimensions Millimeters (Inches)

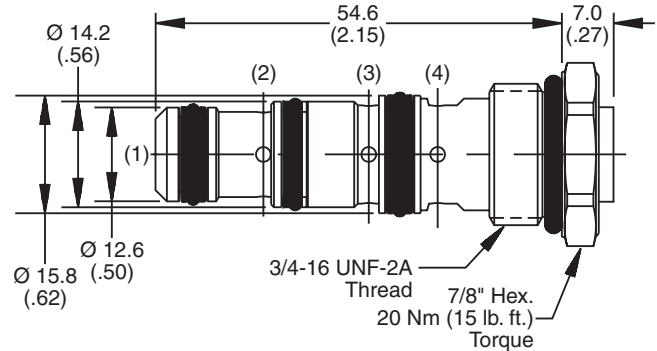

Ordering Information

CPD084P

08 Size **Seals** **Body Material** **Port Size**
Dual P.O. Check Valve

Code	Seals / Kit No.
Omit	Nitrile / (SK08-4N)
V	Fluorocarbon / (SK08-4V)

Code	Body Material
Omit	Steel
A	Aluminum

Code	Port Size	Body Part No.
Omit	Cartridge Only	
4T	SAE-4	(B08-4-*4T)
6T	SAE-6	(B08-4-*6T)
6B	3/8" BSPG	(B08-4-*6B)

* Add "A" for aluminum, omit for steel.



CV
Check Valves

SH
Shuttle Valves

LM
Load/Motor Controls

FC
Flow Controls

PC
Pressure Controls

LE
Logic Elements

DC
Directional Controls

MV
Manual Valves

SV
Solenoid Valves

PV
Proportional Valves

CE
Coils & Electronics

BC
Bodies & Cavities

TD
Technical Data

Technical Information

- CV Check Valves
- SH Shuttle Valves
- LM Load/Motor Controls
- FC Flow Controls
- PC Pressure Controls
- LE Logic Elements
- DC Directional Controls
- MV Manual Valves
- SV Solenoid Valves
- PV Proportional Valves
- CE Coils & Electronics
- BC Bodies & Cavities
- TD Technical Data

General Description

Pilot Piston Style Dual Pilot Operated Check Valve. For additional information see Technical Tips on pages CV1-CV4.

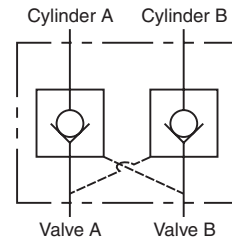
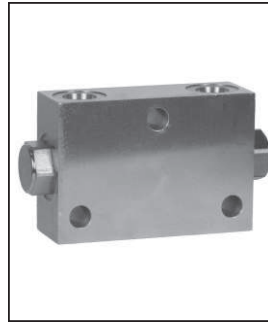

Features

- Spherical poppet for low leakage
- “D”-Ring eliminates back-up rings
- Optional sealed pilot piston

Specifications

Maximum Flow	56 LPM (15 GPM)
Maximum Inlet Pressure	210 Bar (3000 PSI) - CDP081 350 Bar (5000 PSI) - CDPH081
Leakage Across Check 150 SSU (32 cSt)	2 drops/min. (.13 cc/min.)
Leakage Across Pilot Piston (No Seals)	312 cc/min 0.3 LPM (.08 GPM)
Pilot Ratio	4:1
Pilot Piston Part Numbers	No Seal - 718238 Nitrile Seal - 718238N Fluorocarbon Seal - 718238V
Cartridge Material	All parts steel. All operating parts hardened steel.
Body Material	Aluminum - CDP081 Steel - CDPH081
Operating Temp. Range (Ambient)	-45°C to +93.3°C (“D”-Ring) (-50°F to +200°F) -31.7°C to +121.1°C (Fluorocarbon) (-25°F to +250°F)
Filtration	ISO code 16/13, SAE Class 4 or better
Fluids	Mineral-based or synthetic with lubricating properties at viscosities of 45 to 2000 SSU (6 to 420 cSt)
Approx. Weight	

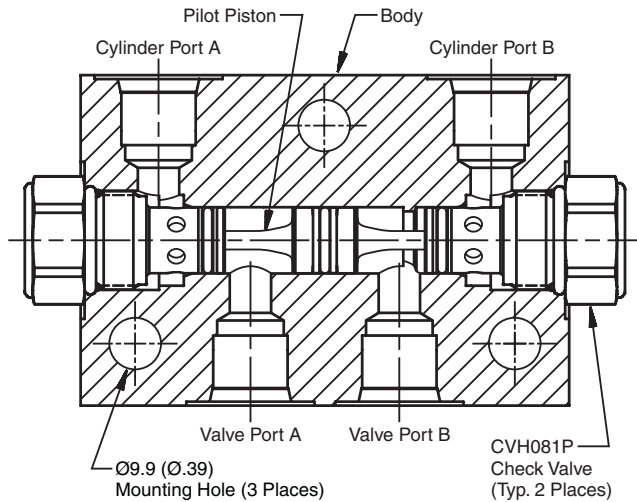

Performance Curve

Pressure Drop vs. Flow (Through cartridge only)

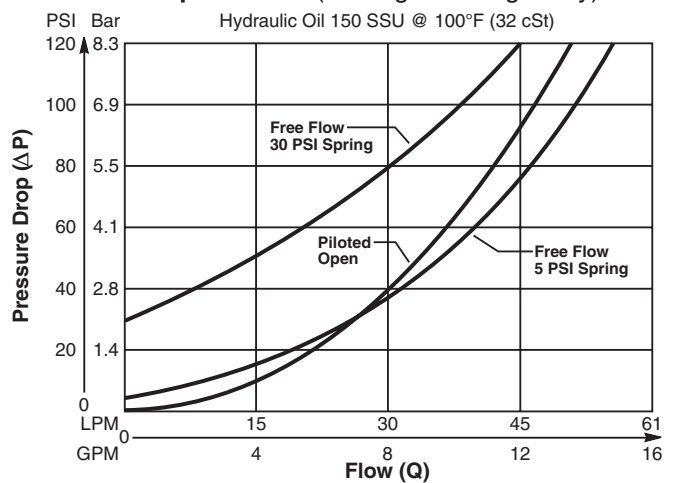

Dimensions Millimeters (Inches)

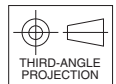
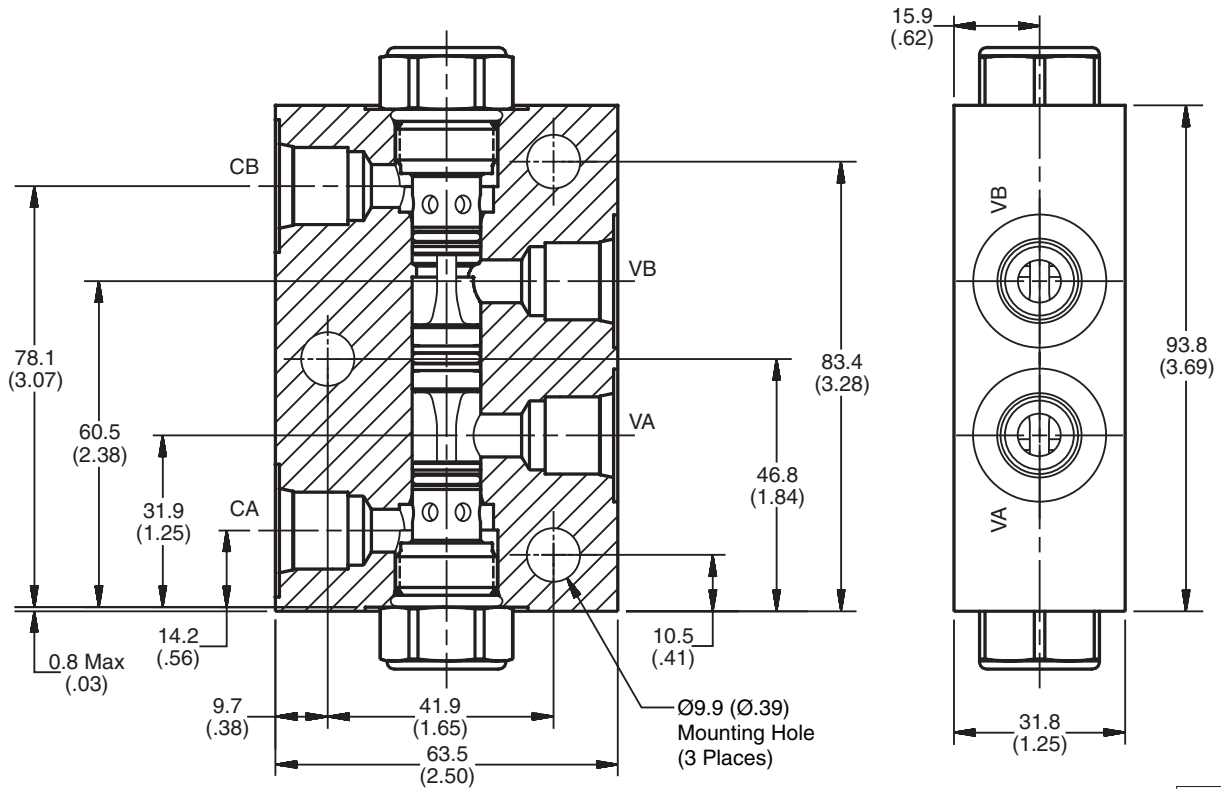

Ordering Information

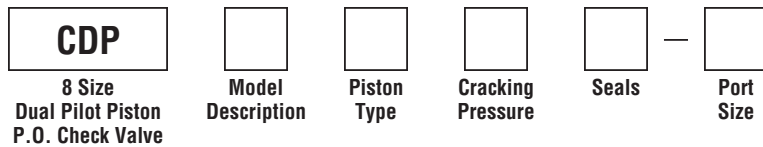

Code	Model Description
081	3000 PSI Series
H081	5000 PSI Series

Code	Cracking Pressure
*Omit	0.3 Bar (5 PSI)
10	0.7 Bar (10 PSI)
30	2.1 Bar (30 PSI)
65	4.5 Bar (65 PSI)
100	6.9 Bar (100 PSI)
150	10.4 Bar (150 PSI)

Code	Seals / Kit No.
Omit	"D"-Ring / (SK08-2)
N	Nitrile / (SK08-2N)
V	Fluorocarbon / (SK08-2V)

Code	Port Size	Material
Omit	Cartridge Only	
A6T	SAE-6	Aluminum (CDP081 Only)
6T	SAE-6	Steel (CDPH081 Only)

Code	Piston Type
P	Pilot Piston without seal
A	Pilot Piston with seal Note: Requires 1.4 Bar (20 PSI) crack minimum.

*Not available with "A" option.

- CV
Check Valves
- SH
Shuttle Valves
- LM
Load/Motor Controls
- FC
Flow Controls
- PC
Pressure Controls
- LE
Logic Elements
- DC
Directional Controls
- MV
Manual Valves
- SV
Solenoid Valves
- PV
Proportional Valves
- CE
Coils & Electronics
- BC
Bodies & Cavities
- TD
Technical Data

Technical Information

- CV Check Valves
- SH Shuttle Valves
- LM Load/Motor Controls
- FC Flow Controls
- PC Pressure Controls
- LE Logic Elements
- DC Directional Controls
- MV Manual Valves
- SV Solenoid Valves
- PV Proportional Valves
- CE Coils & Electronics
- BC Bodies & Cavities
- TD Technical Data

General Description

Pilot Piston Style Dual Pilot Operated Check Valve. For additional information see Technical Tips on pages CV1-CV4.

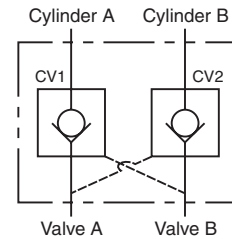
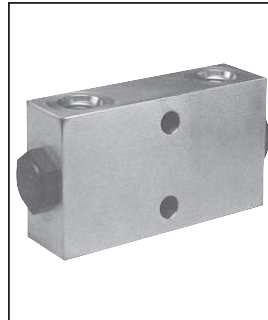

Features

- Spherical poppet for low leakage
- “D”-Ring eliminates back-up rings
- Optional sealed pilot piston

Specifications

Maximum Flow	56 LPM (15 GPM)
Maximum Inlet Pressure	210 Bar (3000 PSI) - CDP103 350 Bar (5000 PSI) - CDPH103
Leakage Across Check 150 SSU (32 cSt)	2 drops/min. (.13 cc/min.)
Leakage Across Pilot Piston (No Seals)	312 cc/min 0.3 LPM (.08 GPM)
Pilot Ratio	4:1
Pilot Piston Part Numbers	No Seal - 717917 Nitrile Seal - 717917N Fluorocarbon Seal - 717917V
Cartridge Material	All parts steel. All operating parts hardened steel.
Body Material	Aluminum - CDP103 Steel - CDPH103
Operating Temp. Range (Ambient)	-45°C to +93.3°C (“D”-Ring) (-50°F to +200°F) -31.7°C to +121.1°C (Fluorocarbon) (-25°F to +250°F)
Filtration	ISO code 16/13, SAE Class 4 or better
Fluids	Mineral-based or synthetic with lubricating properties at viscosities of 45 to 2000 SSU (6 to 420 cSt)
Approx. Weight	

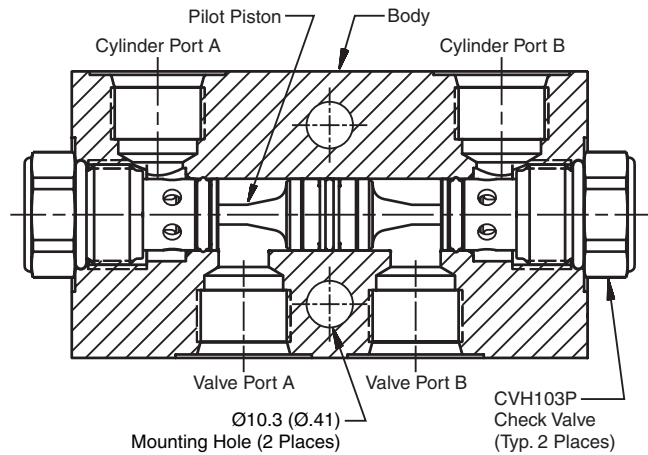

Performance Curve

Pressure Drop vs. Flow (Through cartridge only)

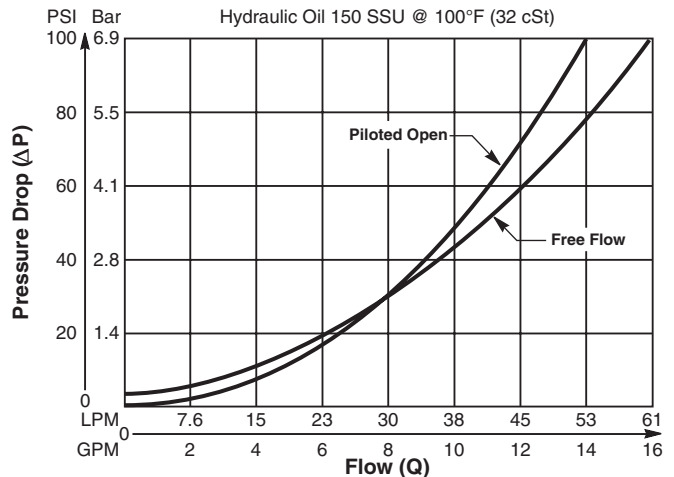

Technical Information

Dimensions Millimeters (Inches)

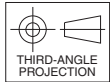
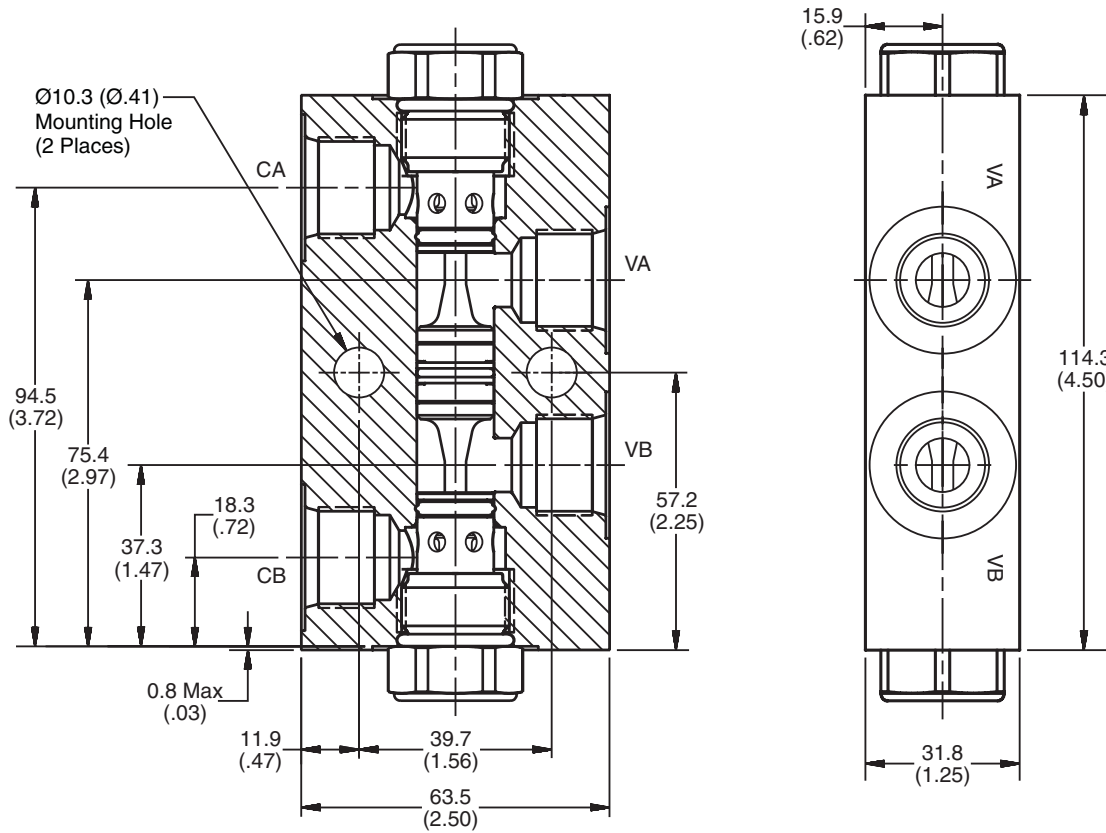

Ordering Information

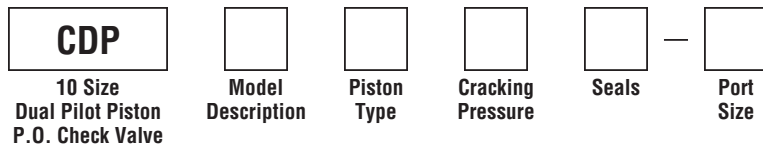

Code	Model Description
103	3000 PSI Series
H103	5000 PSI Series

Code	Cracking Pressure
*Omit	0.3 Bar (5 PSI)
20	1.4 Bar (20 PSI)
50	3.5 Bar (50 PSI)
65	4.5 Bar (65 PSI)
80	5.5 Bar (80 PSI)
100	6.9 Bar (100 PSI)

Code	Seals / Kit No.
Omit	"D"-Ring / (SK10-2)
N	Nitrile / (SK10-2N)
V	Fluorocarbon / (SK10-2V)

Code	Port Size	Material
Omit	Cartridge Only	
A8T	SAE-8	Aluminum (CDP103 Only)
8T	SAE-8	Steel (CDPH103 Only)

Code	Piston Type
P	Pilot Piston without seal
A	Pilot Piston with seal Note: Requires 1.4 Bar (20 PSI) crack minimum.

*Not available with "A" option.

- CV Check Valves
- SH Shuttle Valves
- LM Load/Motor Controls
- FC Flow Controls
- PC Pressure Controls
- LE Logic Elements
- DC Directional Controls
- MV Manual Valves
- SV Solenoid Valves
- PV Proportional Valves
- CE Coils & Electronics
- BC Bodies & Cavities
- TD Technical Data

Technical Information

CV

Check Valves

SH

Shuttle Valves

LM

Load/Motor Controls

FC

Flow Controls

PC

Pressure Controls

LE

Logic Elements

DC

Directional Controls

MV

Manual Valves

SV

Solenoid Valves

PV

Proportional Valves

CE

Coils & Electronics

BC

Bodies & Cavities

TD

Technical Data

General Description

Pilot Piston Style Dual Pilot Operated Check Valve. For additional information see Technical Tips on pages CV1-CV4.

Features

- Hardened precision ground parts for durability
- Optional sealed pilot piston

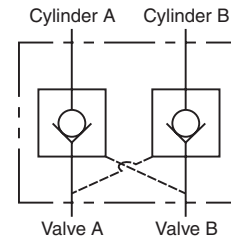
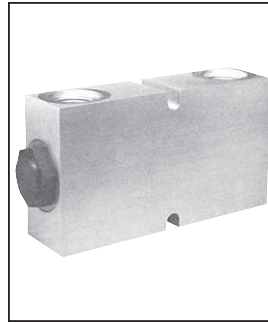

Specifications

Maximum Flow	187 LPM (50 GPM)
Maximum Inlet Pressure	210 Bar (3000 PSI) - CDP161 350 Bar (5000 PSI) - CDPH161
Leakage at 150 SSU (32 cSt)	5 drops/min (.33 cc/min) @ 350 Bar (5000 psi)
Leakage Across Pilot Piston (No Seals)	312 cc/min 0.3 LPM (.08 GPM)
Pilot Ratio	3:1
Pilot Piston Part Numbers	No Seal - 717918 Nitrile Seal - 717918N Fluorocarbon - 717918V
Cartridge Material	All parts steel. All operating parts hardened steel.
Body Material	Aluminum - CDP161 Steel - CDPH161
Operating Temp. Range (Ambient)	-40°C to +93.3°C (Nitrile) (-40°F to +200°F) -31.7°C to +121.1°C (Fluorocarbon) (-25°F to +250°F)
Filtration	ISO code 16/13, SAE Class 4 or better
Fluids	Mineral-based or synthetic with lubricating properties at viscosities of 45 to 2000 SSU (6 to 420 cSt)
Approx. Weight	

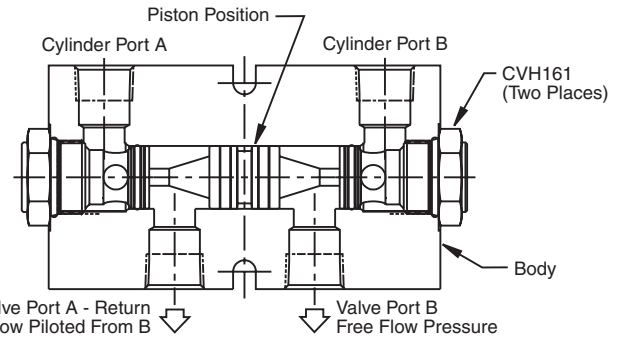

Performance Curve

Pressure Drop vs. Flow (Through cartridge only)

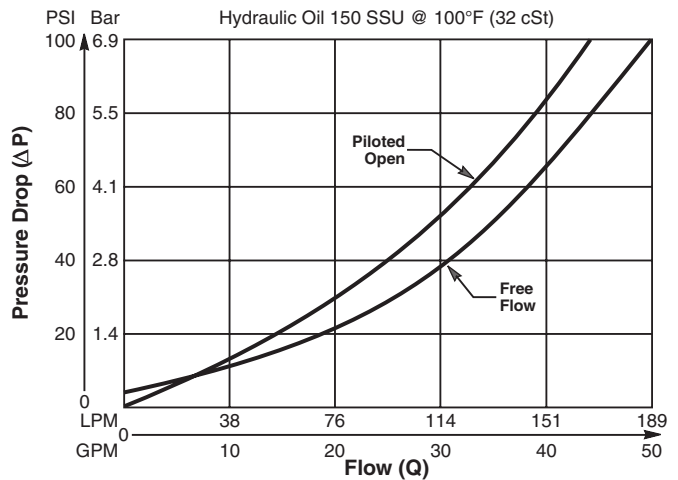

Technical Information

Dimensions Millimeters (Inches)

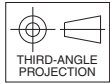
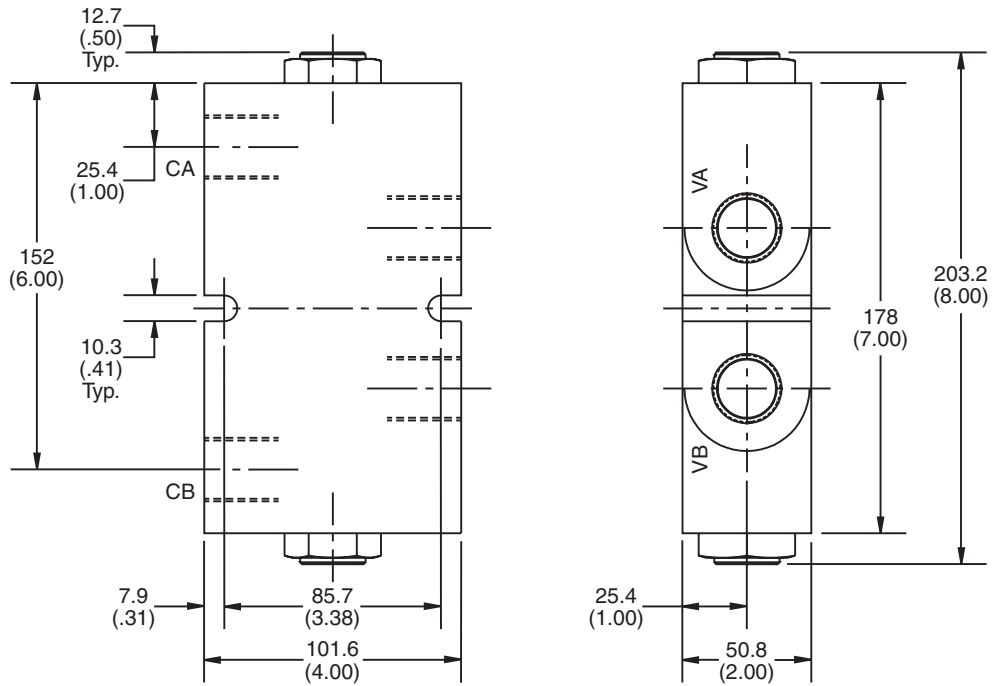

Ordering Information

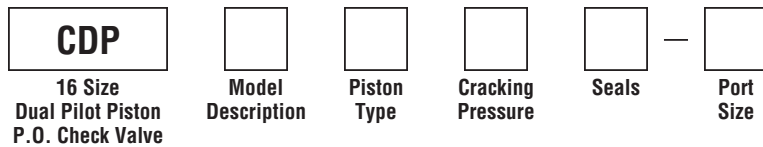

Code	Model Description
161	3000 PSI Series
H161	5000 PSI Series

Code	Cracking Pressure
*Omit	0.3 Bar (5 PSI)
20	1.4 Bar (20 PSI)
65	4.5 Bar (65 PSI)
175	12.1 Bar (175 PSI)

Code	Seals / Kit No.
Omit	Nitrile / (SK16-2N)
V	Fluorocarbon / (SK16-2V)

Code	Port Size	Material
Omit	Cartridge Only	
A16T	SAE-16	Aluminum (CDP161 Only)
16T	SAE-16	Steel (CDPH161 Only)

Code	Piston Type
P	Pilot Piston without seal
A	Pilot Piston with seal Note: Requires 1.4 Bar (20 PSI) crack minimum.

*Not available with "A" option.

- CV
Check Valves
- SH
Shuttle Valves
- LM
Load/Motor Controls
- FC
Flow Controls
- PC
Pressure Controls
- LE
Logic Elements
- DC
Directional Controls
- MV
Manual Valves
- SV
Solenoid Valves
- PV
Proportional Valves
- CE
Coils & Electronics
- BC
Bodies & Cavities
- TD
Technical Data

Technical Information

- CV Check Valves
- SH Shuttle Valves
- LM Load/Motor Controls
- FC Flow Controls
- PC Pressure Controls
- LE Logic Elements
- DC Directional Controls
- MV Manual Valves
- SV Solenoid Valves
- PV Proportional Valves
- CE Coils & Electronics
- BC Bodies & Cavities
- TD Technical Data

General Description

Poppet Type Check Valve with Relief Feature. For additional information see Technical Tips on pages CV1-CV4.

Features

- Poppet type for minimal leakage - less than 3 drops/min.
- Relief feature to give thermal and shock relief protection
- Compact space saving design
- Hardened working parts for maximum durability
- Single and dual pilot pistons available to create pilot to open check
- Good contamination tolerance
- All external parts zinc plated

Performance Curve

Pressure Drop vs. Flow (Through cartridge only)

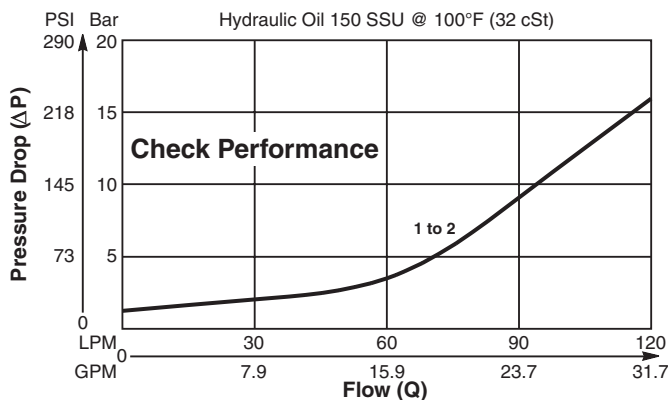

Specifications

Rated Flow	130 LPM (40 GPM)
Nominal Flow @ 7 Bar (100 PSI)	72 LPM (19 GPM)
Maximum Inlet Pressure	420 Bar (6000 PSI)
Leakage at 150 SSU (32 cSt)	Less than 3 drops/min.
Cartridge Material	All parts steel. All operating parts hardened steel.
Operating Temp. Range/Seals	-40°C to +93.3°C (Nitrile, Buna-N) (-40°F to +200°F) -31.7°C to +121.1°C (Fluorocarbon) (-25°F to +250°F)
Fluid Compatibility/Viscosity	Mineral-based or synthetic with lubricating properties at viscosities of 45 to 2000 SSU (6 to 420 cSt)
Filtration	ISO code 16/13, SAE Class 4 or better
Approx. Weight	.13 kg (.29 lbs.)
Cavity	C10-2 (See BC Section for more details)

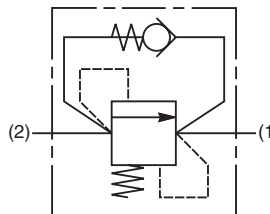
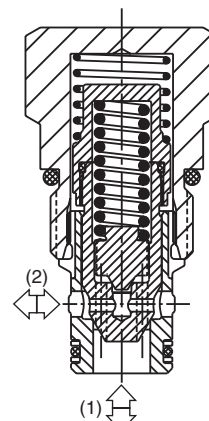

Dimensions Millimeters (Inches)

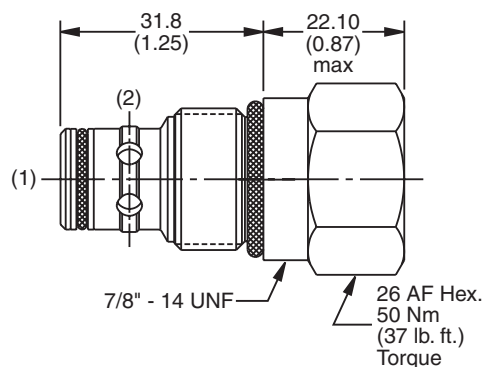

Ordering Information

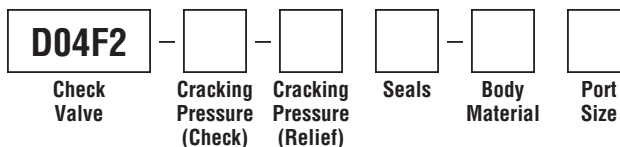

Code	Cracking Pressure (Check)
2.5	2.5 Bar (36 PSI)
7.0	7.0 Bar (102 PSI)

Code	Body Material
Omit	Steel
A	Aluminum

Code	Cracking Pressure (Relief)
35	35 Bar (507 PSI)
245	245 Bar (3553 PSI)
276	276 Bar (4000 PSI)

Code	Port Size	Body Part No.
Omit	Cartridge Only	
4P	1/4" NPTF	(B10-2-*4P)
6P	3/8" NPTF	(B10-2-*6P)
8P	1/2" NPTF	(B10-2-*8P)
6T	SAE-6	(B10-2-*6T)
8T	SAE-8	(B10-2-*8T)
T8T	SAE-8	(B10-2-T8T)†
6B	3/8" BSPG	(B10-2-6B)†

Code	Seals / Kit No.
N	Nitrile, Buna-N / (SK30503N-1)
V	Fluorocarbon / (SK30503V-1)

* Add "A" for aluminum, omit for steel.
† Steel body only.

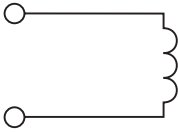
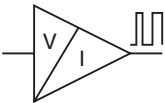
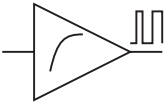
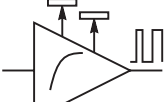

	SERIES	DESCRIPTION	PAGE NO.
	SUPER COILS		
	CC	1/2" Solenoid Tubes	CE3-CE4
	CA	5/8" Solenoid Tubes	CE5-CE6
	STANDARD COILS		
	Unicoil	1/2" Solenoid Tubes	CE7-CE8
	Unicoil	5/8" Solenoid Tubes	CE9-CE10
	DS	1/2" Solenoid Tubes	CE11-CE12
	DS	5/8" Solenoid Tubes	CE13-CE14
	DS	1" Solenoid Tubes	CE15
		ELECTRONICS	
XPR0902		12 VDC PWM Controller, 110Hz, 19W	CE17-CE18
XPR0932		12 VDC PWM Controller, 110Hz, 30W	CE17-CE18
XPR0904		24 VDC PWM Controller, 110Hz, 19W	CE17-CE18
XPR0934		24 VDC PWM Controller, 110Hz, 30W	CE17-CE18
XPR0902d		12 VDC PWM Controller, 95-230Hz, 19W	CE19-CE20
XPR0932d		12 VDC PWM Controller, 95-230Hz, 30W	CE19-CE20
XPR0904d		24 VDC PWM Controller, 95-230Hz, 19W	CE19-CE20
XPR0934d		24 VDC PWM Controller, 95-230Hz, 30W	CE19-CE20
XPR0902rid		12 VDC PWM Controller, 95-230Hz, 19W, Multi-adj.	CE21-CE22
XPR0932rid	12 VDC PWM Controller, 95-230Hz, 30W, Multi-adj.	CE21-CE22	
XPR0904rid	24 VDC PWM Controller, 95-230Hz, 19W, Multi-adj.	CE21-CE22	
XPR0934rid	24 VDC PWM Controller, 95-230Hz, 30W, Multi-adj.	CE21-CE22	
	XPR0704	Soft Start Valve Controller, 12/24 VDC	CE23
	XPR0704b	Soft Start and Stop Valve Controller, 12/24 VDC	CE24
	XPR0804	Power Saver Controller, 12/24 VDC PWM	CE25

CV

Check Valves

SH

Shuttle Valves

LM

Load/Motor Controls

FC

Flow Controls

PC

Pressure Controls

LE

Logic Elements

DC

Directional Controls

MV

Manual Valves

SV

Solenoid Valves

PV

Proportional Valves

CE

Coils & Electronics

BC

Bodies & Cavities

TD

Technical Data

CV	Check Valves
SH	Shuttle Valves
LM	Load/Motor Controls
FC	Flow Controls
PC	Pressure Controls
LE	Logic Elements
DC	Directional Controls
MV	Manual Valves
SV	Solenoid Valves
PV	Proportional Valves
CE	Coils & Electronics
BC	Bodies & Cavities
TD	Technical Data

INTRODUCTION

This technical tips section is designed to help familiarize you with the Parker line of Coils. In this section we highlight the features and discuss some of the available options. We also use this section to present some common terminology related to coil and coil technology.

New Parker **SUPER COIL** Now Available!

Class N Magnetic Wire
Internal wires have a class N rating, providing longer life at typical temperatures.

DC Windings
All coils are DC wound. An internal full wave rectifier is added for AC current, eliminating inrush current, and allowing for voltage interchangeability.

Variety of Terminations
Coils are offered in a wide variety of terminations, including integrally molded connectors and voltages to meet your system requirements.

Rugged Thermoplastic Encapsulation
Coil is encased in a thermoplastic polyester resin. This allows for higher temperature exposure and less flexural creep. Also, this resin is resistant to moisture, caustic solutions, and fungus providing protection for coil windings.

Low Carbon Steel Frame
Zinc plated low carbon steel frame surrounds coil, increasing flux density. Low carbon steel provides better magnetic properties and greater permeability.

Diodes
Internally molded diodes are available. Polarity is molded into coil for ease of installation.

Ribbed Surface
External ridges provide a larger coil surface area, which allows for better heat dissipation.

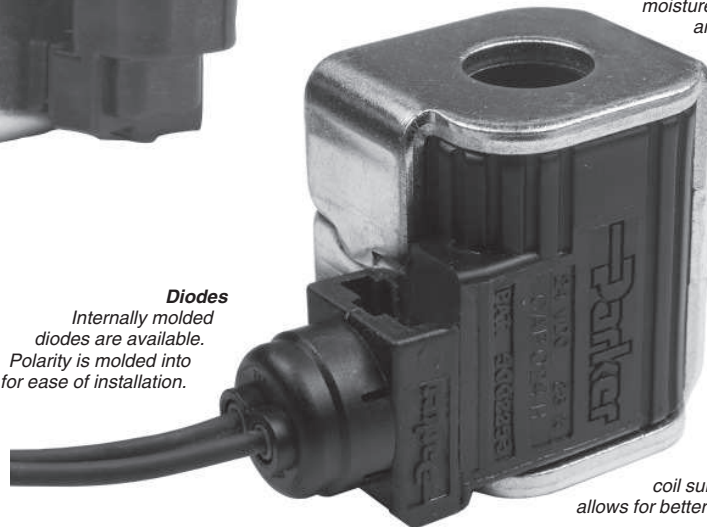

***Exceeds IP69k Specifications**

After exhaustive testing, the new Super Coil has clearly distanced itself from the competition. This coil was subjected to the rigors of this environmental standard and the results were excellent. This coil stands up to most rugged of environmental conditions including weather, dust, and extreme temperature variations.

***Water Dunk Test Qualified**

The Super Coil was taken to task in a repeated water dunk thermal cycle test program with alternate exposure to high and low temperature, only to perform with outstanding results.

***Endurance Tested**

The goal of this test was to cycle the coil to high temperature extremes in order to validate the coils ability to perform in extreme temperature environments.

***Water Spray and Chemical Solvent Compatibility**

The Super Coil was subjected to numerous chemical solvents in a rigorous test which established the fact that these coils can withstand harsh and unusual environments. Also, the coils were subjected to a high pressure water spray test. Once again, the Super Coil passed this test.

**Deutsch molded connector or LS option is highly recommended.*

NOTE: LS coil option will be available January 1, 2011.

COMMON OPTIONS

Below are some of the common options to the Unicoil product offering.

Continuous Duty: Parker's standard line of coils are rated for continuous duty operation. This means the coil can be left on continuously without fear of the magnet wire insulation breakdown, when used in standard climate conditions. The Unicoils and Super Coils are made of a high quality Class N magnet wire. This Class N rating signifies the internal wires are rated to 200°C (392°F).

Continuous duty does not mean the coil will have the same amount of power after hours of operation as it had at initial actuation. Coils do heat up during use. This internal heat rise increases the resistance of the coil and thus, decreases the current ($V = IR$). The performance curves presented on the solenoid valve pages are based on a coil at room temperature and 85% of voltage. Thus, when using a valve in continuous duty applications, you may need to derate the performance. In short, the continuous duty rating signifies that while the coil will get hot during use and resistance will increase, it will not generate enough heat to damage the coil.

Terminations: Parker offers a wide variety of coil terminations for all coils to meet the demands of your application. Over the years, the dual lead wire and dual spade offerings have been popular due to their ease of installation and availability. In the past few years, the demand for more secure termination connections has increased. In addition, the integral connectors reduce cost and improve integrity by reducing the number of connections. As such, the Amp Junior, Weatherpack, Metri-Pack, and Deutsch have increased in popularity. We offer these connectors on a lead wire coil, as well as an internally molded version of the DIN, Amp Junior, and Metri-Pack coils. If you do not find your desired coil termination in our catalog, contact your factory sales representative. We have added a Sealed Leadwire option to meet IP69K requirements yet still allow for other lead wire options.

Current Types: Both direct current (DC) and alternating current (AC) versions are available for the Parker line of coils. The AC versions are essentially DC coils with a full wave rectifier integrally molded into the coil. The rectifiers are rated for voltage peaks up to 1000 volts maximum. For voltage transients greater than 1000 volts, a Harris Thyrector is recommended. The AC coils operate at 50/60 cycles (Hz). Since the AC versions are rectified

DC coils, there is no inrush current like with "true" AC coils. It also means DC coils and AC coils are interchangeable.

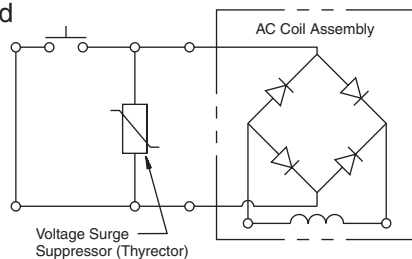

Voltages: Parker has a wide selection of coils available to meet your needs. Most coil terminations are available with our standard voltages of 12V and 24V in DC, and 120V and 240V in AC. Voltages 6V, 10V, 18V, 36V, 48V DC and 440V AC are also available for many termination types at a slight premium. Contact your Parker representative should your application call for voltages other than our standard offering.

Diodes: The Parker Coils can be ordered with a diode molded internally. Parker Unicoils use a 1N5062 diode. The Super Coils use a 1N5627 diode. Diodes are sometimes used to protect sensitive, downstream electrical components from potential surges from the coil. By internally molding the diode into the coil, you can reduce the assembly time and cost associated with externally wiring a diode. One should be careful not to switch the polarity ("+" and "-" terminals), when wiring a coil with an internal diode. If these terminals are switched, the first time voltage is applied to the coil; the short circuit will destroy the diode and render the coil use-less. Parker coils with diodes have "+" and "-" molded near the termination outlet to help identify polarity.

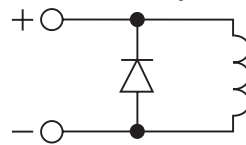

DIN Connectors: Parker does offer connectors for use with the DIN style coils. As shown below, the DIN connectors are available in both rectified and non-rectified forms. The cable gland versions can be ordered for type PG9 or PG11.

Cable Gland

Type	Non-Rectified	Rectified
PG9	710549-00	712126-01
PG11	710549-01	712126-00

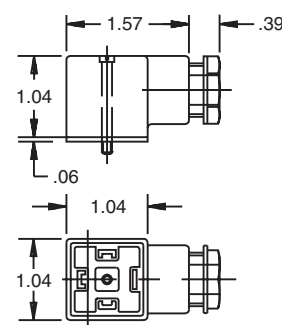

Conduit

Rectified
712704-00

Conduit

Non-Rectified
710549-02

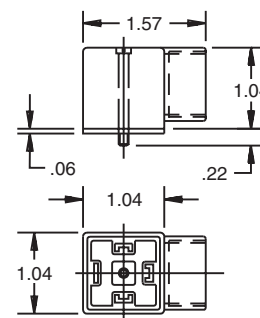
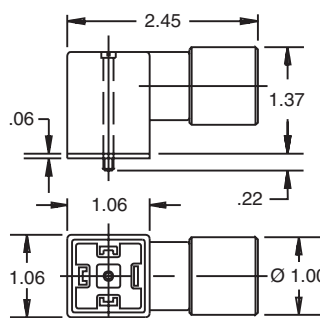

Technical Information

- CV Check Valves
- SH Shuttle Valves
- LM Load/Motor Controls
- FC Flow Controls
- PC Pressure Controls
- LE Logic Elements
- DC Directional Controls
- MV Manual Valves
- SV Solenoid Valves
- PV Proportional Valves
- CE Coils & Electronics
- BC Bodies & Cavities
- TD Technical Data

Features

- Integral Deutsch connector coil exceeds IP69K standards
- Integral Deutsch connector coil thermal shock dunk test rated
- Integral Amp Jr. coil exceeds IP67 standards for thermal shock, water resistance and "dunk capability"
- Universal 50/60 Hz operation
- Waterproof coil hermetically sealed, requires no O-rings or waterproofing kits
- External plated steel flux-carrying band (unlike encapsulated band) enables coil to withstand severe thermal shocks without cracking
- Symmetrical coil can be reversed without affecting performance

Specifications

Coil Type	S Standard	P Puissant
Nominal Wattage (See Ordering Information For Exact Wattage)	S 14 Watts	P 19 Watts
Duty Cycle	Continuous @ 100% voltage	
Magnetic Wire Insulation Class	'N' Rated at 200°C (392°F)	
Temperature Range	-40°C to +200°C (-40°F to +392°F)	
Temperature Rise At Nominal Voltage And Natural Ventilation	S 75°C (135°F)	P 95°C (172°F)
Dielectric Strength Maximum Current Leakage (Amps)	.0005 In dry lab condition at 1000V AC for 30 seconds .001 After being immersed in 23°C (77°F) water with waterproof connector for 24 hours at 500V AC	
Encapsulating Material	Glass filled rynite	
Color Identification On The Terminal Boss	S Black Ring	P Red Ring
Weight	0.20 kg (0.44 lbs.)	

AC Coil Assembly

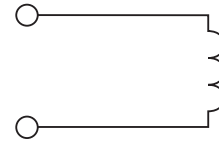
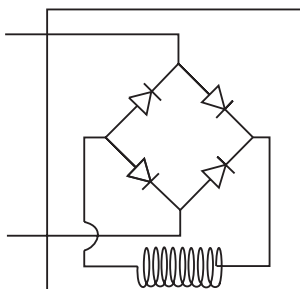

Ordering Information

CC

Super Coil Wattage Voltage Termination
1/2" I.D.

Code	Wattage
S	Standard
P	Puissant

Code	Voltage	Watts		Amps		Ohms**	
		S	P	S	P	S	P
010	10 VDC	14	19	1.38	1.90	7.25	5.26
012*	12 VDC	14	19	1.15	1.58	10.43	7.58
018	18 VDC	14	19	0.77	1.06	23.48	17.05
024*	24 VDC	14	19	0.58	0.79	41.74	30.30
048	48 VDC	14	19	0.29	0.40	167.0	121.3
115*	115 VAC	16	19	0.17	0.20	680	576
230	230 VAC	17	22	0.09	0.12	2596	1919

*Standard Voltages **Resistance ±10% at 68°F

Code	Termination
A	Amp Jr. (DC Only)
AD	Amp Jr. with 3 Amp Diode (DC Only)
C	Double Lead Wire with Conduit Connector (AC Only)
*D	DIN 43650 (AC or DC, Supplied without DIN Connector)
H	Integral Deutsch
HE	Integral Deutsch with 3 Amp Diode
*L	Double Lead (DC Only)
LS	Sealed Lead Wire IP69K Rated (Available January 1, 2011)
LD	Double Lead with Deutsch Connector DT04-2P-EP04 (DC Only) (Use 'H' series if possible)
LE	Double Lead with 3 Amp Diode (DC Only)
PF	Double Lead Wire with Packard Female Weather Pack Connector 1201 5792 (DC Only)
PM	Double Lead Wire with Packard Male Weather Pack Connector 1201 0973 (DC Only)
*S	Double Spade (DC Only)
*W	Double Screw (DC only)
WE	Double Screw with 3 Amp Diode (DC Only)
*Y	Single Screw (Internally Grounded, DC Only)

*UL listed 12/24/48 VDC only.

Note: Additional voltages and other terminals are available. Some coils are UL approved. For details please consult factory.

DIN Female Mating Connector: See page CE2

Deutsch Mating Connector: # DT06-2S

Packard Male Weather Pack Connector: 12010973

Packard Female Weather Pack Connector: 12015792

Terminal Styles and Dimensions

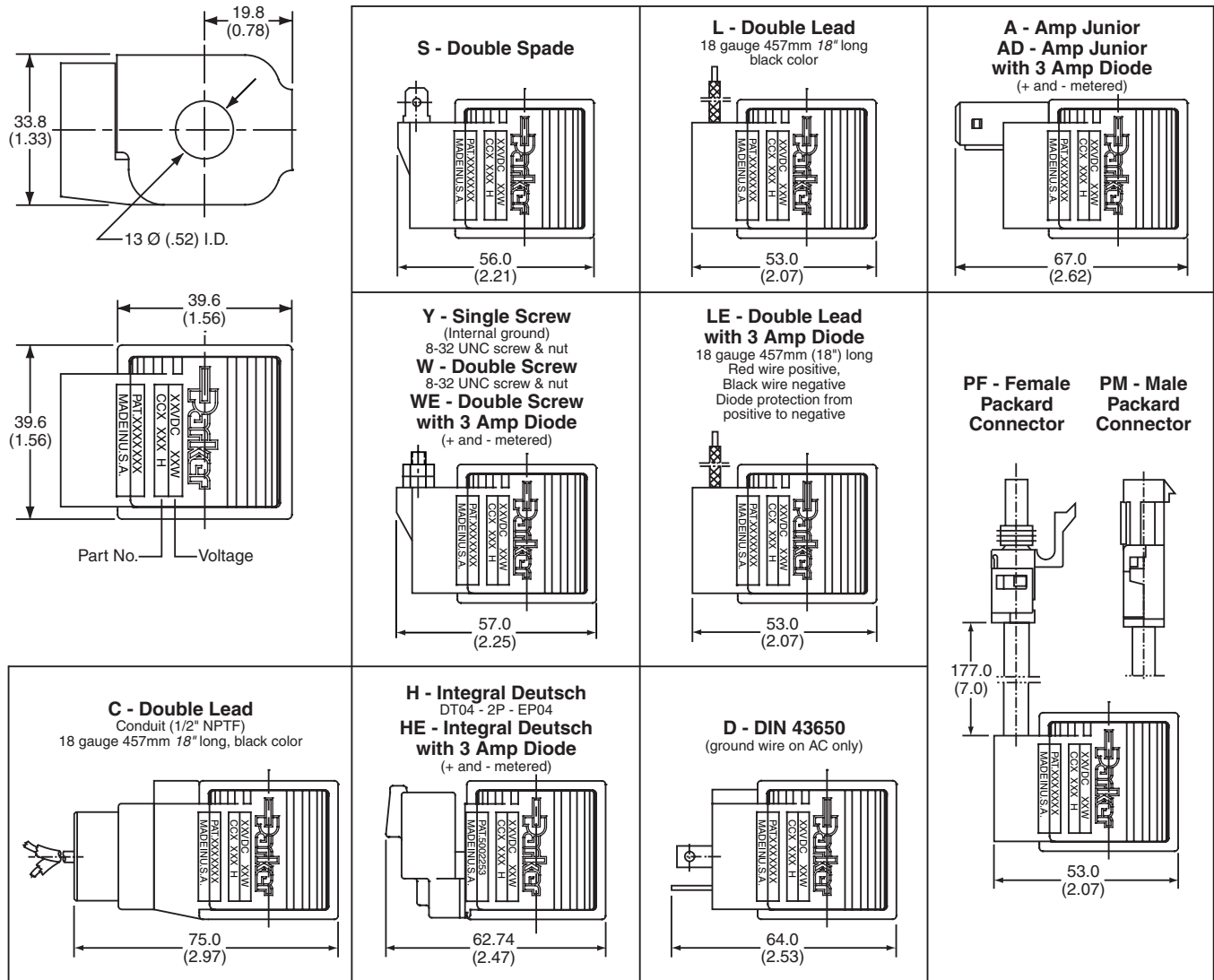

- NOTES:**
1. The standard A.C. coil includes a molded-in full wave rectifier rated for 800 peak reverse voltage.
 2. All P Puissant (high wattage) coils use a red ring as an indication marker on the terminal boss.

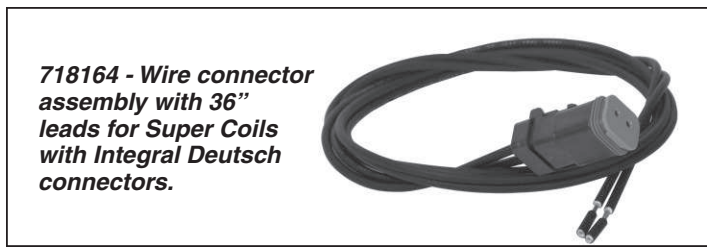

- CV** Check Valves
- SH** Shuttle Valves
- LM** Load/Motor Controls
- FC** Flow Controls
- PC** Pressure Controls
- LE** Logic Elements
- DC** Directional Controls
- MV** Manual Valves
- SV** Solenoid Valves
- PV** Proportional Valves
- CE** Coils & Electronics
- BC** Bodies & Cavities
- TD** Technical Data

Technical Information

- CV Check Valves
- SH Shuttle Valves
- LM Load/Motor Controls
- FC Flow Controls
- PC Pressure Controls
- LE Logic Elements
- DC Directional Controls
- MV Manual Valves
- SV Solenoid Valves
- PV Proportional Valves
- CE Coils & Electronics
- BC Bodies & Cavities
- TD Technical Data

Features

- Integral Deutsch connector coil exceeds IP69K standards
- Integral Deutsch connector coil thermal shock dunk test rated
- Integral Amp Jr. coil exceeds IP67 standards for thermal shock, water resistance and "dunk capability"
- Universal 50/60 Hz operation
- Coil hermetically sealed, requires no O-rings or waterproofing kits
- External plated steel flux-carrying band (unlike encapsulated band) enables coil to withstand severe thermal shocks without cracking
- Symmetrical coil can be reversed without affecting performance

Specifications

Coil Type	S	Standard
	P	Puissant
Nominal Wattage (See Ordering Information For Exact Wattage)	S	18 Watts
	P	28 Watts
Duty Cycle	Continuous @ 100% voltage	
Magnetic Wire Insulation Class	'N' Rated at 200°C (392°F)	
Temperature Range	-40°C to +200°C (-40°F to +392°F)	
Temperature Rise At Nominal Voltage And Natural Ventilation	S	75°C (135°F)
	P	95°C (172°F)
Dielectric Strength Maximum Current Leakage (Amps)	.0005 In dry lab condition at 1000V AC for 30 seconds	
	.001 After being immersed in 23°C (77°F) water with waterproof connector for 24 hours at 500V AC	
Encapsulating Material	Glass filled rynite	
Color Identification On The Terminal Boss	S	Black Ring
	P	Red Ring
Weight	0.29 kg (0.64 lbs.)	

AC Coil Assembly

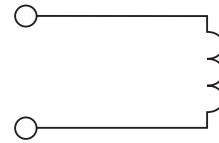
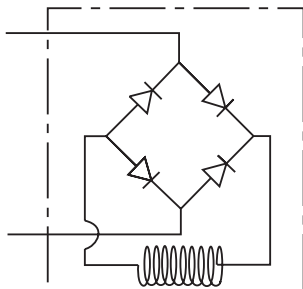

Ordering Information

CA			
Super Coil 5/8" I.D.	Wattage	Voltage	Termination

Code	Wattage
S	Standard
P	Puissant

Code	Voltage	Watts		Amps		Ohms**	
		S	P	S	P	S	P
010	10 VDC	18	28	1.80	2.80	5.56	3.57
012*	12 VDC	18	28	1.50	2.33	8.00	5.14
018	18 VDC	18	28	1.00	1.56	18.0	11.6
024*	24 VDC	18	28	0.75	1.17	32.0	20.6
048	48 VDC	18	28	0.38	0.58	128.0	82.3
115*	115 VAC	18	28	0.20	0.26	554	417
230	230 VAC	18	28	0.10	0.15	2100	1430

*Standard Voltages **Resistance ±10% at 68°F

Code	Termination
A	Amp Jr. (DC Only)
AD	Amp Jr. with 3 Amp Diode (DC Only)
C	Double Lead Wire with Conduit Connector (AC Only)
*D	DIN 43650 (AC or DC, Supplied without DIN Connector)
H	Integral Deutsch
HE	Integral Deutsch with 3 Amp Diode
HS	Integral Deutsch with Internal Seal
*L	Double Lead (DC Only)
LS	Sealed Lead Wire IP69K Rated (Available January 1, 2011)
LD	Double Lead with Deutsch Connector DT04-2P-EP04 (DC Only) (Use 'H' series if possible)
LE	Double Lead with 3 Amp Diode (DC Only)
PF	Double Lead Wire with Packard Female Weather Pack Connector 1201 5792 (DC Only)
PM	Double Lead Wire with Packard Male Weather Pack Connector 1201 0973 (DC Only)
*S	Double Spade (DC Only)
*W	Double Screw (DC only)
WE	Double Screw with 3 Amp Diode (DC Only)
*Y	Single Screw (Internally Grounded, DC Only)

*UL listed 12/24/48 VDC only.

Note: Additional voltages and other terminals are available. Some coils are UL approved. For details please consult factory.

DIN Female Mating Connector: See page CE2

Deutsch Mating Connector: # DT06-2S

Packard Male Weather Pack Connector: 12010973

Packard Female Weather Pack Connector: 12015792

Terminal Styles and Dimensions

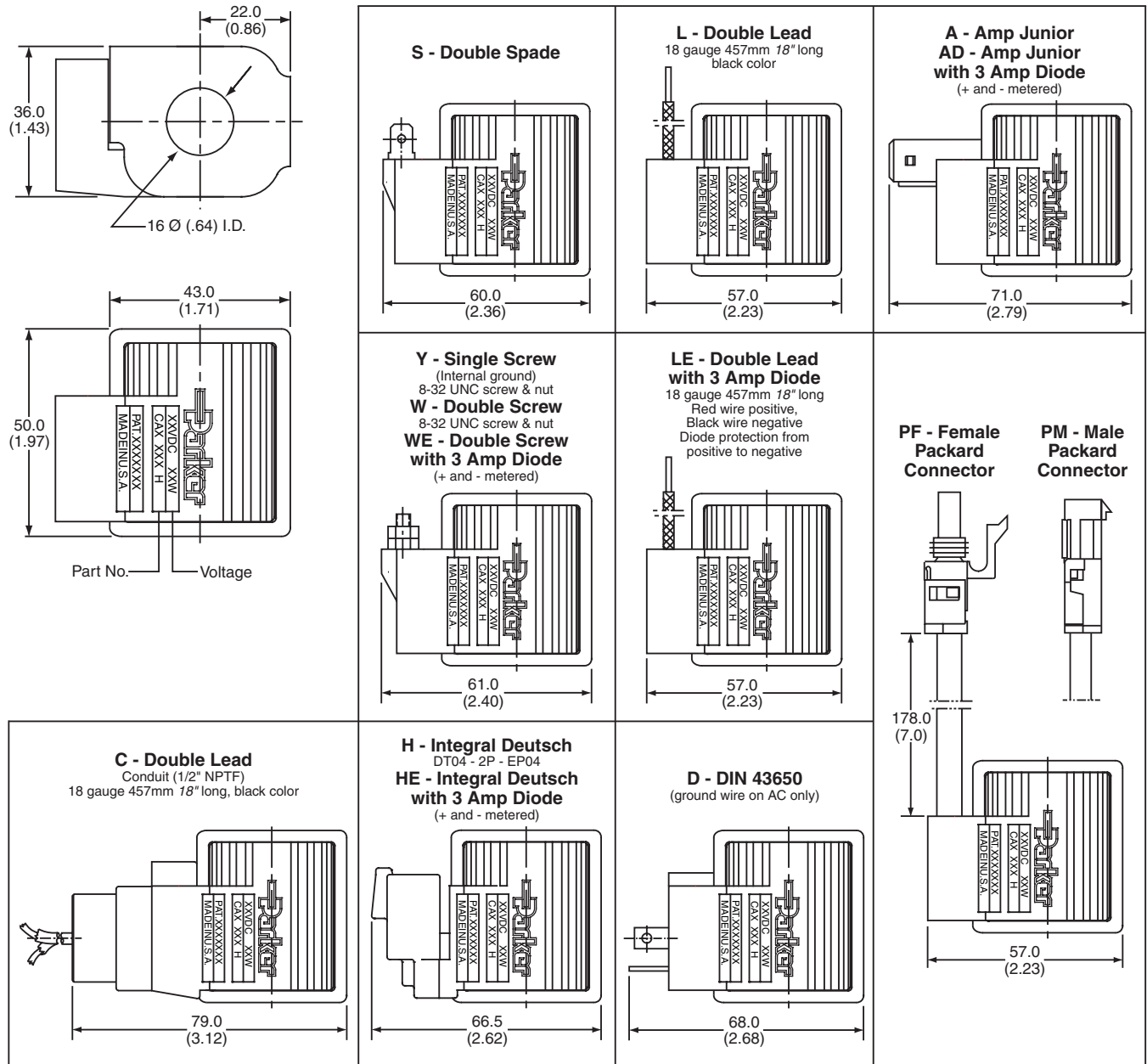

NOTES:

1. The standard A.C. coil includes a molded-in full wave rectifier rated for 800 peak reverse voltage.
2. All P Puissant (high wattage) coils use a red ring as an indication marker on the terminal boss. (No ring on Integral Deutsch connector.)

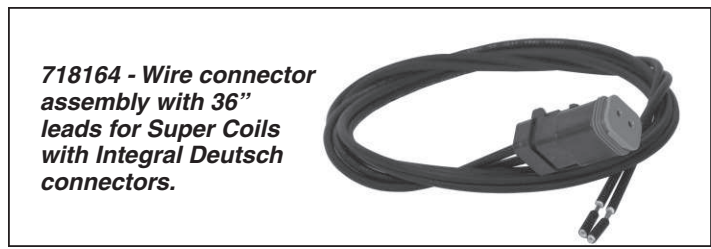

- CV** Check Valves
- SH** Shuttle Valves
- LM** Load/Motor Controls
- FC** Flow Controls
- PC** Pressure Controls
- LE** Logic Elements
- DC** Directional Controls
- MV** Manual Valves
- SV** Solenoid Valves
- PV** Proportional Valves
- CE** Coils & Electronics
- BC** Bodies & Cavities
- TD** Technical Data

Technical Information

- CV** Check Valves
- SH** Shuttle Valves
- LM** Load/Motor Controls
- FC** Flow Controls
- PC** Pressure Controls
- LE** Logic Elements
- DC** Directional Controls
- MV** Manual Valves
- SV** Solenoid Valves
- PV** Proportional Valves
- CE** Coils & Electronics
- BC** Bodies & Cavities
- TD** Technical Data

Features

- Compact one piece encapsulated design
- Minimal amperage draw
- Numerous terminals and voltages
- Coil designed for use with series DSL and DSH type valves only
- Coils made with high quality Class N magnet wire
- Superior thick internal iron frame surrounding copper windings to increase the flux density
- More ampere turns to deliver more magnetic flux per input voltage
- A.C. coil operates @ 50/60 cycle (Hz)

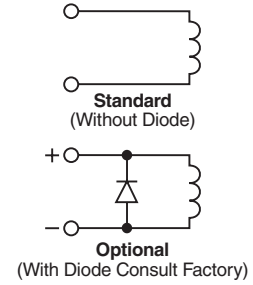
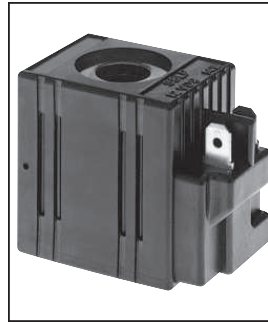

Specifications

Wattage	14 Watts
Duty Rating	Continuous @ 100% voltage
Wire Class	Class N - 200°C (392°F)
Heat Rise	45°C (115°F) over ambient
A.C. Rectifier	Integral full wave bridge
Lead Wire	18 gauge 24" long, 600 volt rating
Lead Wire Strain Relief	34 kg (75 lbs.) @ 21°C (70°F) & 18 kg (40 lbs.) @ 93°C (200°F)
Encapsulating Material	Rynite, resistant to moisture, caustic solutions, fungus, and temperatures from -40°C (-40°F) to 200°C (392°F)
Finish	Coil - Black Frame - Yellow zinc dichromate

Coil Accessories For DIN Connector 43650

Cable Gland

Type	Non-Rectified	Rectified
PG9	710549-00	712126-01
PG11	710549-01	712126-00

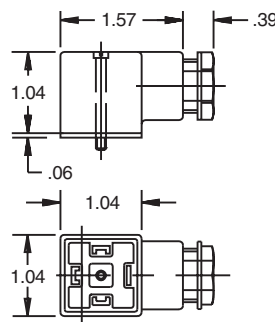

Conduit

Rectified
712704-00

Conduit

Non-Rectified
710549-02

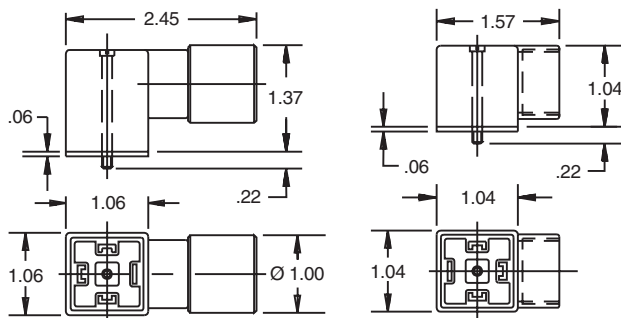

Ordering Information

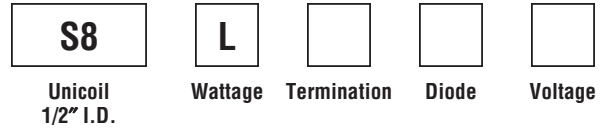

Code	Wattage
L	14 Watt

Code	Diode
Omit	Without Diode
R	Diode

Diode not available with all connectors.

Code	Termination
C	*Conduit With Leads
D	*DIN Plug Face
J	Amp Jr.
M	Metri-Pack
P	*Dual Spade
S	*Dual Screw
W	Dual Lead (DC Only)
WS	Weather Pack Shroud 24"

*Diode not available

Code	Voltage	Current Amps	Resistance Ohms	Lead Color
*D006	6 VDC	2.40	2.5	Black
*D010	10 VDC	1.45	6.9	Yellow
D012	12 VDC	1.17	10.2	Red
*D018	18 VDC	0.84	21.5	Gray
D024	24 VDC	0.57	41.8	Blue
*D036	36 VDC	0.45	80.5	Orange
*D048	48 VDC	0.32	150.6	Green
A120	120 VAC	0.16	663	Brown
A240	240 VAC	0.07	3032	White

* Consult Factory.

Terminal Styles and Dimensions

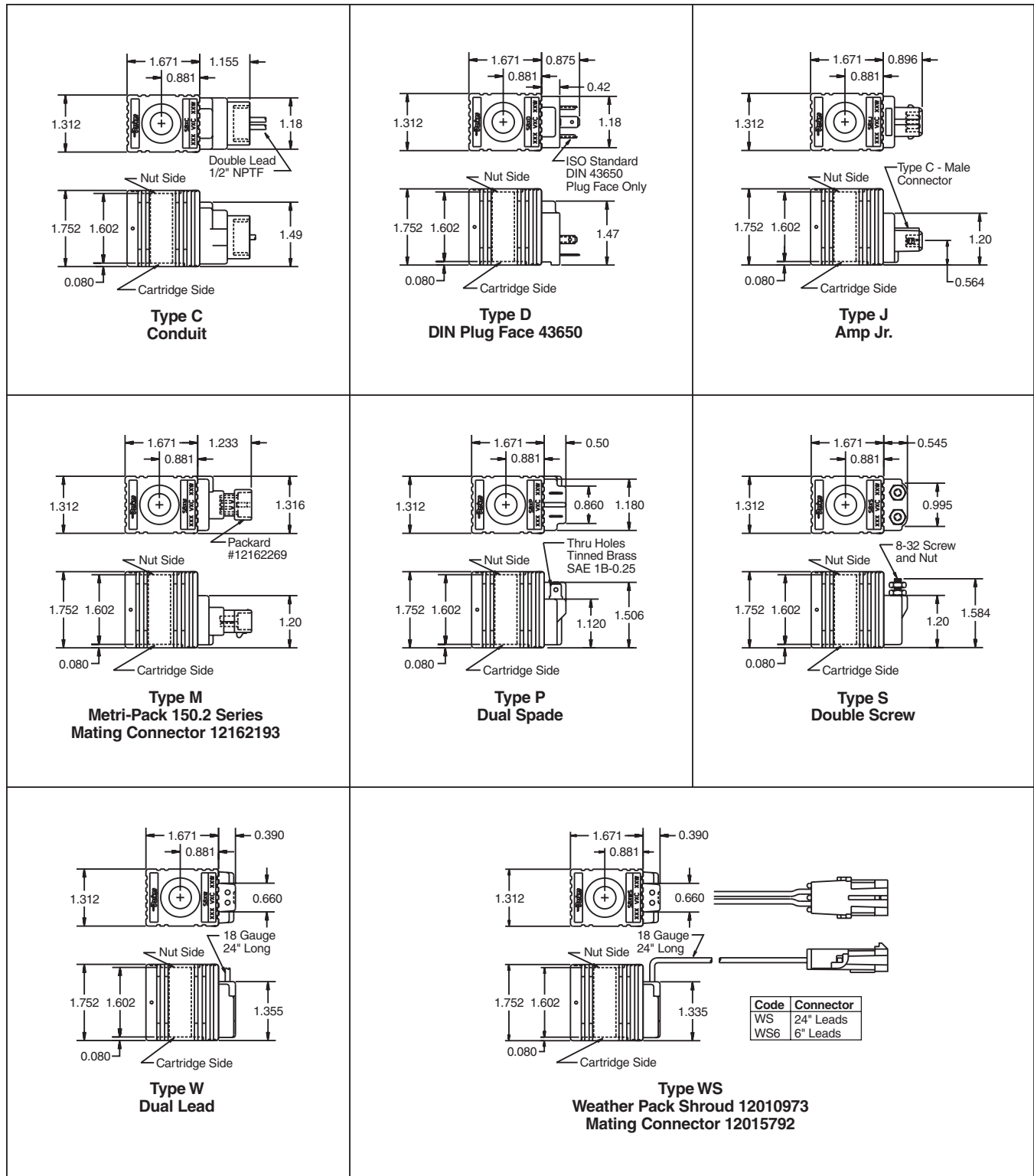

CV
Check Valves

SH
Shuttle Valves

LM
Load/Motor Controls

FC
Flow Controls

PC
Pressure Controls

LE
Logic Elements

DC
Directional Controls

MV
Manual Valves

SV
Solenoid Valves

PV
Proportional Valves

CEI
Coils & Electronics

BC
Bodies & Cavities

TD
Technical Data

Technical Information

- CV** Check Valves
- SH** Shuttle Valves
- LM** Load/Motor Controls
- FC** Flow Controls
- PC** Pressure Controls
- LE** Logic Elements
- DC** Directional Controls
- MV** Manual Valves
- SV** Solenoid Valves
- PV** Proportional Valves
- CE** Coils & Electronics
- BC** Bodies & Cavities
- TD** Technical Data

Features

- Compact one piece encapsulated design
- Minimal amperage draw
- Numerous terminals and voltages
- Coil designed for use with series DSL and DSH type valves only
- Coils made with high quality Class N magnet wire
- Superior thick internal iron frame surrounding copper windings to increase the flux density
- More ampere turns to deliver more magnetic flux per input voltage
- A.C. coil operates @ 50/60 cycle (Hz)

Specifications

Wattage	20 Watts
Duty Rating	Continuous @ 100% voltage
Wire Class	Class N - 200°C (392°F)
Heat Rise	45°C (115°F) over ambient
A.C. Rectifier	Integral full wave bridge
Lead Wire	18 gauge 24" long, 600 volt rating
Lead Wire Strain Relief	34 kg (75 lbs.) @ 21°C (70°F) & 18 kg (40 lbs.) @ 93°C (200°F)
Encapsulating Material	Rynite, resistant to moisture, caustic solutions, fungus, and temperatures from -40°C (-40°F) to 200°C (392°F)
Finish	Coil - Black Frame - Yellow zinc dichromate

Coil Accessories For DIN Connector 43650

Cable Gland

Type	Non-Rectified	Rectified
PG9	710549-00	712126-01
PG11	710549-01	712126-00

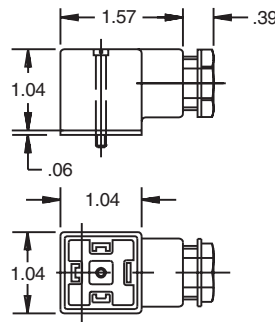

Conduit

Rectified
712704-00

Conduit

Non-Rectified
710549-02

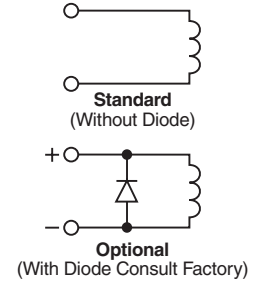
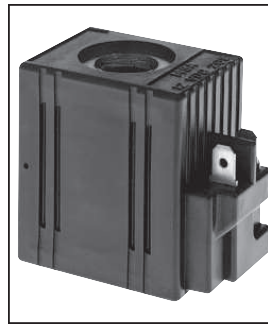
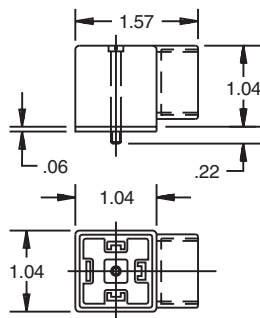
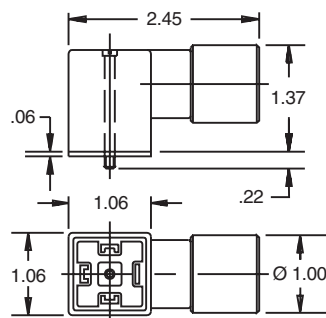

Ordering Information

S10	L			
Unicoil 5/8" I.D.	Wattage	Termination	Diode	Voltage

Code	Wattage
L	20 Watt

Code	Diode
Omit	Without Diode
R	Diode

Diode not available with all connectors.

Code	Termination
C	*Conduit With Leads
D	*DIN Plug Face
J	Amp Jr.
M	Metri-Pack
P	*Dual Spade
S	*Dual Screw
W	Dual Lead (DC Only)
WS	Weather Pack Shroud 24"

*Diode not available

Code	Voltage	Current Amps	Resistance Ohms	Lead Color
*D006	6 VDC	3.33	1.8	Black
*D010	10 VDC	2.10	4.8	Yellow
D012	12 VDC	1.67	7.2	Red
*D018	18 VDC	1.21	14.9	Gray
D024	24 VDC	0.88	27.4	Blue
*D036	36 VDC	0.61	58.9	Orange
*D048	48 VDC	0.47	102.4	Green
A120	120 VAC	0.192	626	Brown
A240	240 VAC	0.10	2400	White

* Consult Factory.

Terminal Styles and Dimensions

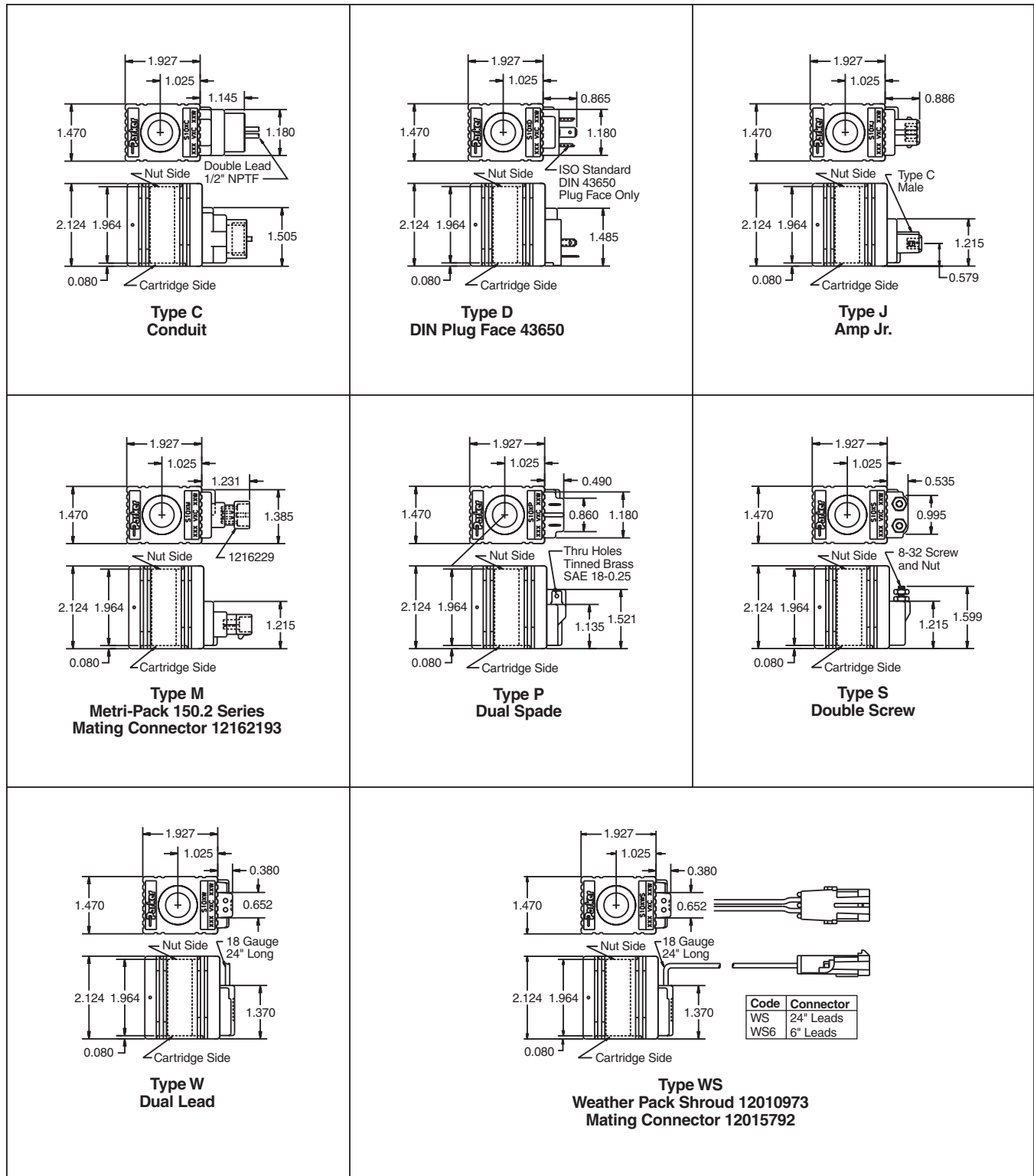

- CV** Check Valves
- SH** Shuttle Valves
- LM** Load/Motor Controls
- FC** Flow Controls
- PC** Pressure Controls
- LE** Logic Elements
- DC** Directional Controls
- MV** Manual Valves
- SV** Solenoid Valves
- PV** Proportional Valves
- CE** Coils & Electronics
- BC** Bodies & Cavities
- TD** Technical Data

Technical Information

- CV** Check Valves
- SH** Shuttle Valves
- LM** Load/Motor Controls
- FC** Flow Controls
- PC** Pressure Controls
- LE** Logic Elements
- DC** Directional Controls
- MV** Manual Valves
- SV** Solenoid Valves
- PV** Proportional Valves
- CE** Coils & Electronics
- BC** Bodies & Cavities
- TD** Technical Data

Features

- Compact one piece encapsulated design
- Minimal amperage draw
- Numerous terminals and voltages
- High watt design available for intermittent operation
- Heavy gauge color coded lead wire with built-in strain relief
- 180°C Class H wire standard
- 200°C Class N wire on high watt models

Specifications

Wattage	12 Watts — Standard - Black Coil 25 Watts — High Watt - Red Coil
Duty Rating	Continuous @ 100% voltage
Wire Class	Class H for all voltages 12 Watt Class N for all voltages 25 Watt
A.C. Rectifier	Integral full wave bridge
Lead Wire	18 gauge 24" long, 600 volt rating
Lead Wire Strain Relief	34 kg (75 lbs.) @ 21°C (70°F) & 18 kg (40 lbs.) @ 93°C (200°F)
Encapsulating Material	Glass filled nylon, resistant to moisture, caustic solutions, fungus, and temperatures from -40°C (-40°F) to 200°C (392°F)

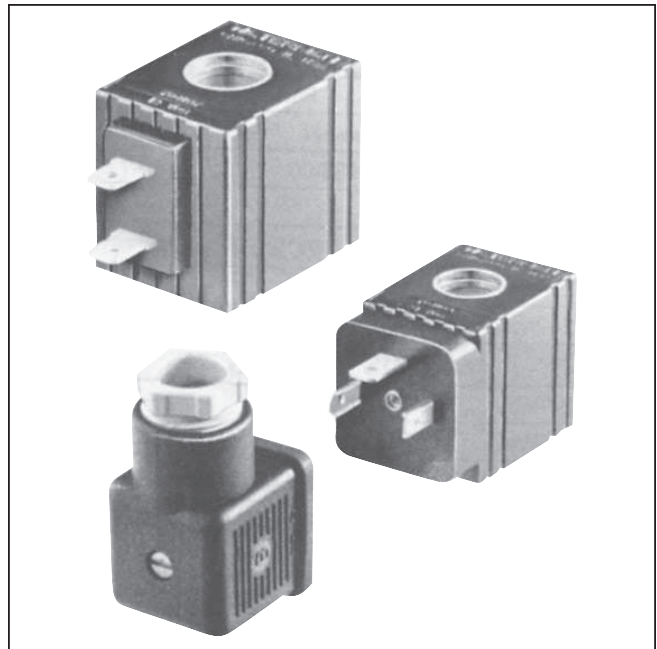

Symbol

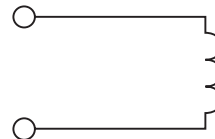

AC Coil Assembly

No inductive or capacitive loads can be installed between surge suppressor and rectified valves.

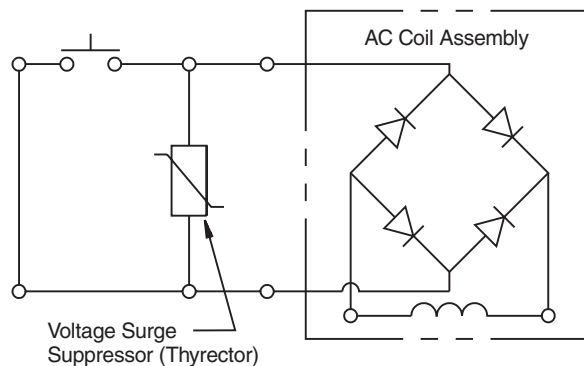

NOTE:

Parker A.C. Coils incorporate integrally molded full wave rectifiers which are rated for reverse voltage peaks of 1000 volts maximum. For voltage transients greater than 1000 volts P.I.V., Harris Thyrector V150LA10A or V150LA20A for 115 VAC and V250LA15A or V250LA40A for 200 VAC is recommended.

Terminal Styles and Dimensions

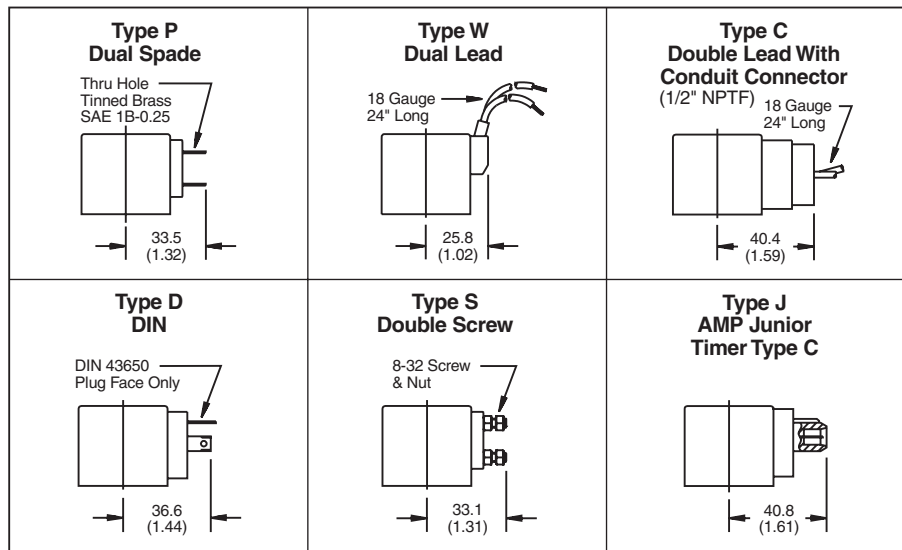
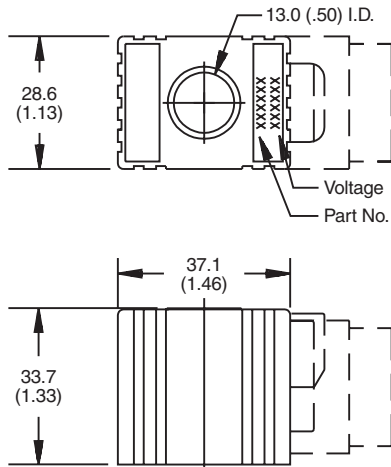

NOTES:

1. Coil to be installed with part number on nut side.
2. For additional terminals, voltages and wattages, consult factory for details.

Coil Part Numbers

Voltage	Watts	Type P Double Spade	Type W Double Lead	Type C Conduit Connector	Type D DIN Plug Face	Type S Double Screw	Amps†	Lead Wire Color
**6 VDC	12	851007-006	851009-006	851003-006*	851005-006*	851011-006	2.22	Black
	25	851008-006	851010-006	851004-006	851006-006	851012-006	3.90	
**10 VDC	12	851007-010	851009-010	851003-010*	851005-010*	851011-010	1.43	Yellow
	25	851008-010	851010-010	851004-010	851006-010	851012-010	2.48	
12 VDC	12	851007-012	851009-012	851003-012*	851005-012*	851011-012	1.05	Red
	25	851008-012	851010-012	851004-012	851006-012	851012-012	1.94	
**18 VDC	12	851007-018	851009-018	851003-018*	851005-018*	851011-018	0.75	Gray
	25	851008-018	851010-018	851004-018	851006-018	851012-018	1.42	
24 VDC	12	851007-024	851009-024	851003-024*	851005-024*	851011-024	0.52	Blue
	25	851008-024	851010-024	851004-024	851006-024	851012-024	1.17	
**36 VDC	12	851007-036	851009-036	851003-036*	851005-036*	851011-036	0.38	Orange
	25	851008-036	851010-036	851004-036	851006-036	851012-036	0.73	
**48 VDC	12	851007-048	851009-048	851003-048*	851005-048*	851011-048	0.26	Green
	25	851008-048	851010-048	851004-048	851006-048	851012-048	0.59	
120 VAC	12			851003-120	851005-120		0.14	Brown
	25			851004-120	851006-120		0.23	
230 VAC	12			851003-240	851005-240		0.08	White
	25			851004-240	851006-240		0.12	
**440 VAC	12			851003-480	851005-480		0.04	Violet
	25			851004-480	851006-480		0.07	

**Consult Factory *UL Listed

†Amperage draw @ 21°C (70°F)

- CV**
- Check Valves
- SH**
- Shuttle Valves
- LM**
- Load/Motor Controls
- FC**
- Flow Controls
- PC**
- Pressure Controls
- LE**
- Logic Elements
- DC**
- Directional Controls
- MV**
- Manual Valves
- SV**
- Solenoid Valves
- PV**
- Proportional Valves
- CE**
- Coils & Electronics
- BC**
- Bodies & Cavities
- TD**
- Technical Data

Technical Information

- CV** Check Valves
- SH** Shuttle Valves
- LM** Load/Motor Controls
- FC** Flow Controls
- PC** Pressure Controls
- LE** Logic Elements
- DC** Directional Controls
- MV** Manual Valves
- SV** Solenoid Valves
- PV** Proportional Valves
- CE** Coils & Electronics
- BC** Bodies & Cavities
- TD** Technical Data

Features

- Compact one piece encapsulated design
- Minimal amperage draw
- Numerous terminals and voltages
- High watt design optional
- Heavy gauge color coded lead wire with built-in strain relief
- 180°C Class H wire standard
- 200°C Class N wire on high watt models

Specifications

Wattage	17 Watts — Standard - Black Coil 30 Watts — High Watt - Red Coil
Duty Rating	Continuous @ 100% voltage
Wire Class	Class H for all voltages 17 Watt Class N for all voltages 30 Watt
A.C. Rectifier	Integral full wave bridge
Lead Wire	18 gauge 24" long, 600 volt rating
Lead Wire Strain Relief	34 kg (75 lbs.) @ 21°C (70°F) & 18 kg (40 lbs.) @ 93°C (200°F)
Encapsulating Material	Glass filled nylon, resistant to moisture, caustic solutions, fungus, and temperatures from -40°C (-40°F) to 200°C (392°F)

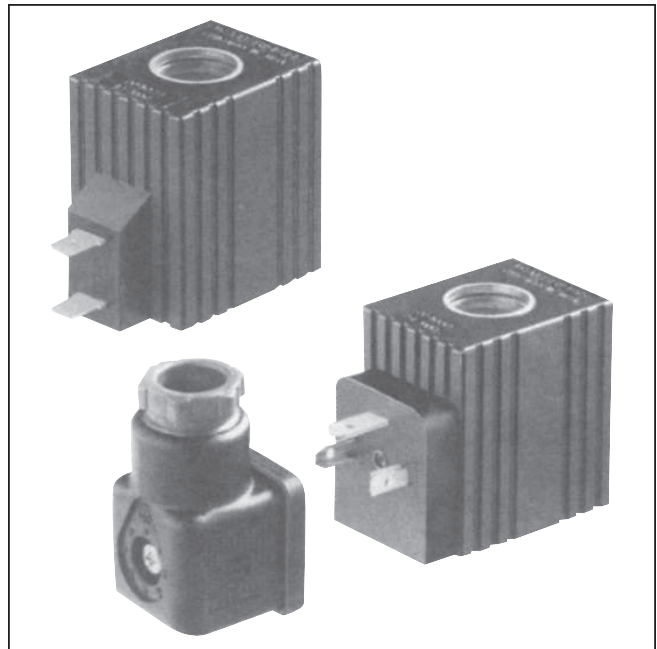

Symbol

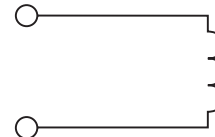

AC Coil Assembly

No inductive or capacitive loads can be installed between surge suppressor and rectified valves.

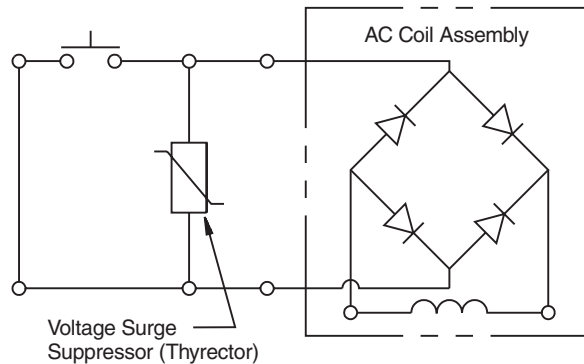

NOTE:

Parker A.C. Coils incorporate integrally molded full wave rectifiers which are rated for reverse voltage peaks of 1000 volts maximum. For voltage transients greater than 1000 volts P.I.V., Harris Thyrector V150LA10A or V150LA20A for 115 VAC and V250LA15A or V250LA40A for 200 VAC is recommended.

Terminal Styles and Dimensions

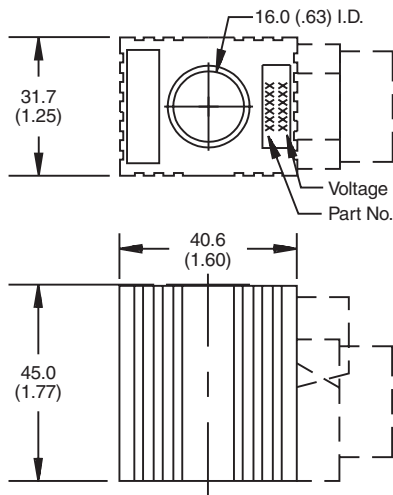

<p>Type P Dual Spade</p> <p>Thru Hole Tinned Brass SAE 1B-0.25</p> <p>38.4 (1.51)</p>	<p>Type W Dual Lead</p> <p>18 Gauge 24" Long</p> <p>28.6 (1.13)</p>	<p>Type C Double Lead With Conduit Connector</p> <p>(1/2" NPTF) 18 Gauge 24" Long</p> <p>42.2 (1.66)</p>
<p>Type D DIN</p> <p>DIN 43650 Plug Face Only</p> <p>40.2 (1.58)</p>	<p>Type J AMP Junior Timer Type C</p> <p>40.8 (1.61)</p>	

NOTES:

1. Coil to be installed with part number on nut side.
2. For additional terminals, voltages and wattages, consult factory for details.

Coil Part Numbers

Voltage	Watts	Type P Double Spade	Type W Double Lead	Type C Conduit Connector	Type D DIN Plug Face	Amps*	Lead Wire Color
6 VDC	17	851021-006	851023-006	851017-006	851019-006	2.43	Black
	30	851022-006	851024-006	851018-006	851020-006	4.84	
10 VDC	17	851021-010	851023-010	851017-010	851019-010	1.58	Yellow
	30	851022-010	851024-010	851018-010	851020-010	3.28	
12 VDC	17	851021-012	851023-012	851017-012	851019-012	1.44	Red
	30	851022-012	851024-012	851018-012	851020-012	2.30	
18 VDC	17	851021-018	851023-018	851017-018	851019-018	0.94	Gray
	30	851022-018	851024-018	851018-018	851020-018	1.86	
24 VDC	17	851021-024	851023-024	851017-024	851019-024	0.72	Blue
	30	851022-024	851024-024	851018-024	851020-024	1.20	
36 VDC	17	851021-036	851023-036	851017-036	851019-036	0.43	Orange
	30	851022-036	851024-036	851018-036	851020-036	0.88	
48 VDC	17	851021-048	851023-048	851017-048	851019-048	0.30	Green
	30	851022-048	851024-048	851018-048	851020-048	0.58	
120 VAC	17			851017-120	851019-120	0.15	Brown
	30			851018-120	851020-120	0.24	
230 VAC	17			851017-240	851019-240	0.08	White
	30			851018-240	851020-240	0.13	
440 VAC	17			851017-480	851019-480	0.04	Violet
	30			851018-480	851020-480	0.07	

*Amperage draw @ 21°C (70°F)

CV Check Valves
SH Shuttle Valves
LM Load/Motor Controls
FC Flow Controls
PC Pressure Controls
LE Logic Elements
DC Directional Controls
MV Manual Valves
SV Solenoid Valves
PV Proportional Valves
CE Coils & Electronics
BC Bodies & Cavities
TD Technical Data

Features

- Compact one piece encapsulated design
- Numerous terminals and voltages
- Heavy gauge color coded lead wire with built-in strain relief
- 200°C Class N wire standard
- U.L. recognized on most DC coils (consult factory)

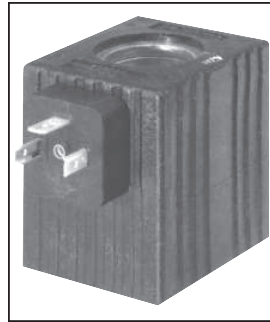

Specifications

Wattage	42 Watts — Standard 30 Watts — Low Watt
Duty Rating	Continuous @ 100% voltage
Wire Class	Class N for all voltages
Lead Wire	18 gauge 24" long, 600 volt rating
Lead Wire Strain Relief	34 kg (75 lbs.) @ 21°C (70°F) & 18 kg (40 lbs.) @ 93°C (200°F)
Encapsulating Material	Glass filled nylon, resistant to moisture, caustic solutions, fungus, and temperatures from -40°C (-40°F) to 200°C (392°F)
Color	Black

AC Coil Assembly

No inductive or capacitive loads can be installed between surge suppressor and rectified valves.

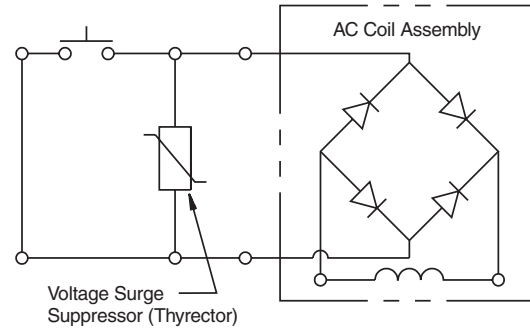

Terminal Styles and Dimensions

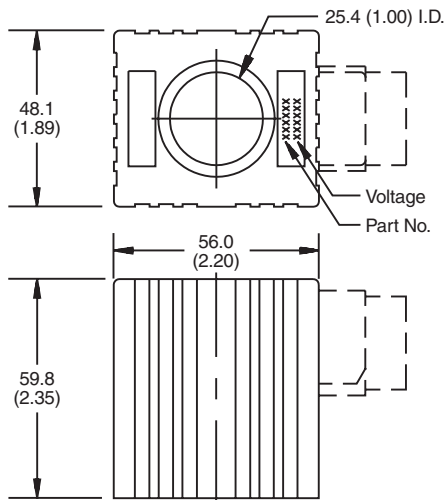

NOTES:

1. Coil to be installed with part number on nut side.
2. For additional terminals, voltages and wattages, consult factory for details.

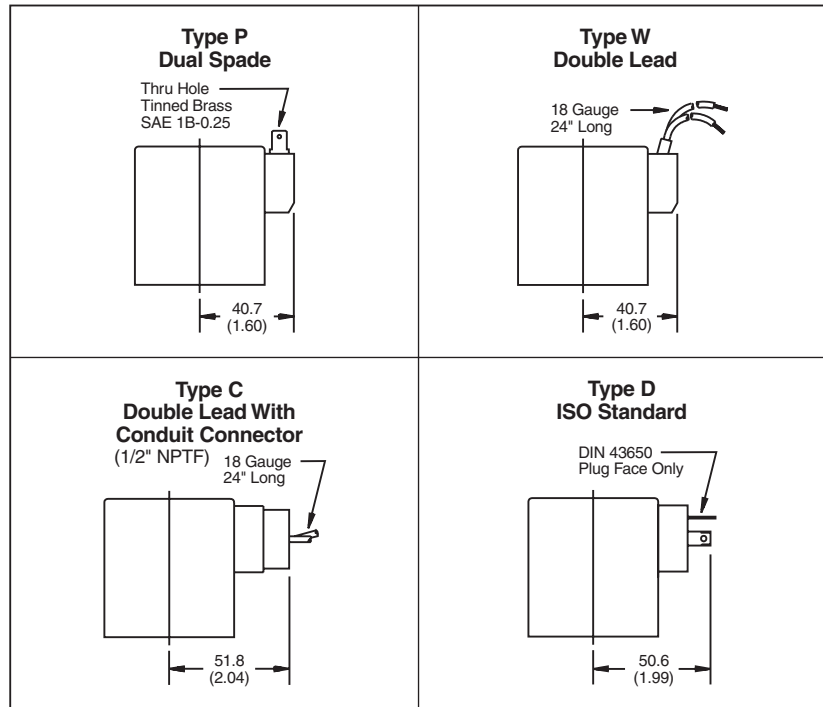

Coil Part Numbers

Wattage	Voltage	Type P Double Spade	Type W Double Lead	Type D ISO STANDARD	Amps	Lead Wire Color
42 Watts	12 VDC	851060-012*	851062-012*	851058-012*	3.53	Red
42 Watts	24 VDC	851060-024*	851062-024*	851058-024*	1.79	Blue
30 Watts	12 VDC	853496-012	853497-012	853495-012	2.50	Red
30 Watts	24 VDC	853496-024	853497-024	853495-024	1.25	Blue

*UL Listed

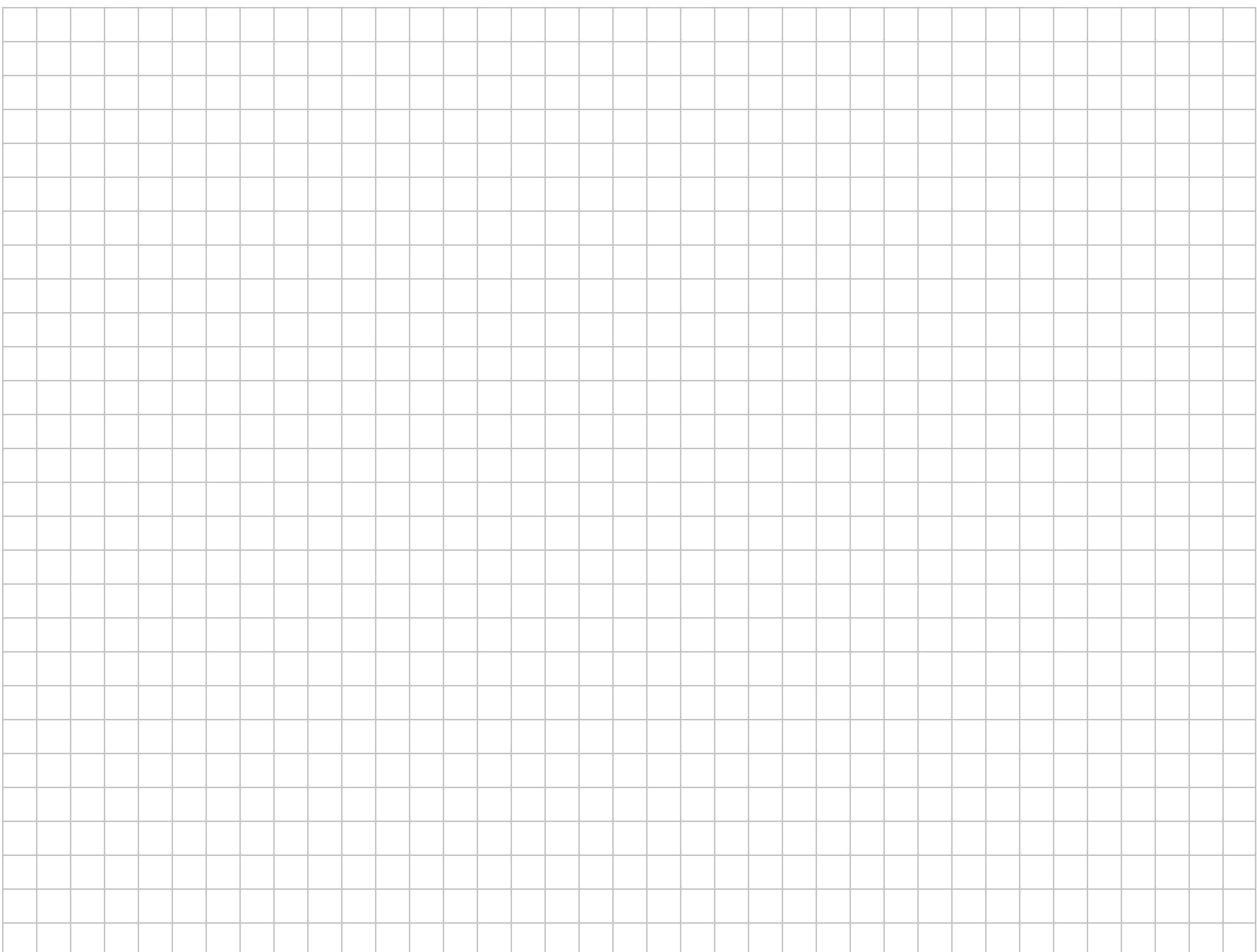

CV	Check Valves
SH	Shuttle Valves
LM	Load/Motor Controls
FC	Flow Controls
PC	Pressure Controls
LE	Logic Elements
DC	Directional Controls
MV	Manual Valves
SV	Solenoid Valves
PV	Proportional Valves
CE	Coils & Electronics
BC	Bodies & Cavities
TD	Technical Data



CV Check Valves
SH Shuttle Valves
LM Load/Motor Controls
FC Flow Controls
PC Pressure Controls
LE Logic Elements
DC Directional Controls
MV Manual Valves
SV Solenoid Valves
PV Proportional Valves
CE Coils & Electronics
BC Bodies & Cavities
TD Technical Data

General Description

Proportional Valve Controllers. 12 and 24 Volts, PWM. For additional information see Technical Tips on pages CE1-CE2.

Operation

The 902/932 and 904/934 are valve top mounted PWM controllers for proportional control valves. They can be used with an external potentiometer to give accurate current control using the units internal reference voltage. Alternatively these controllers can be used with a 0-10V command signal from a PLC or engine management system.

'I Max' adjustment is provided to allow the maximum output current to be set via a 12 turn potentiometer. Turn clockwise to increase the output current.

Notes:

XPRO902 and XPRO932

In order to avoid damaging a controller the +8V (yellow) lead must not be shorted to the +12V (red) lead or to the 0V (blue) lead.

XPRO904 and XPRO934

In order to avoid damaging a controller the +15V (yellow) lead must not be shorted to the +24V (red) lead or to the 0V (blue) lead.

Specifications

Nominal Voltage	XPRO902 12V DC XPRO932 12V DC XPRO904 24V DC XPRO934 24V DC
Maximum Power	XPRO902 19W XPRO932 30W XPRO904 19W XPRO934 30W
(IP) Rating	IP 65
Maximum Current	XPRO902 1.6A XPRO932 2.6A XPRO904 1.0A XPRO934 1.4A
Command Voltage	0 - 10V
Input Resistance	10K ohms
Reference Voltage	XPRO902 +8V (2mA) XPRO932 +8V (2mA) XPRO904 +15V (2mA) XPRO934 +15V (2mA)
Cable Length	1 meter
Frequency	110 Hz ±5%

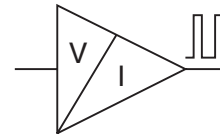
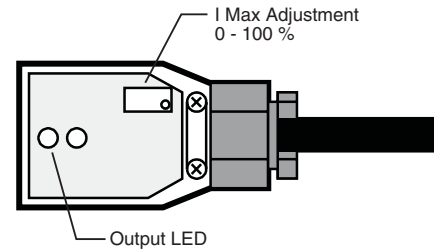

Features

- Self contained DIN 'Plug Top'
- High impact resistant molded ABS
- Complies with current CE regulations

Output Regulation

(Curve shows coil temperature compensation)

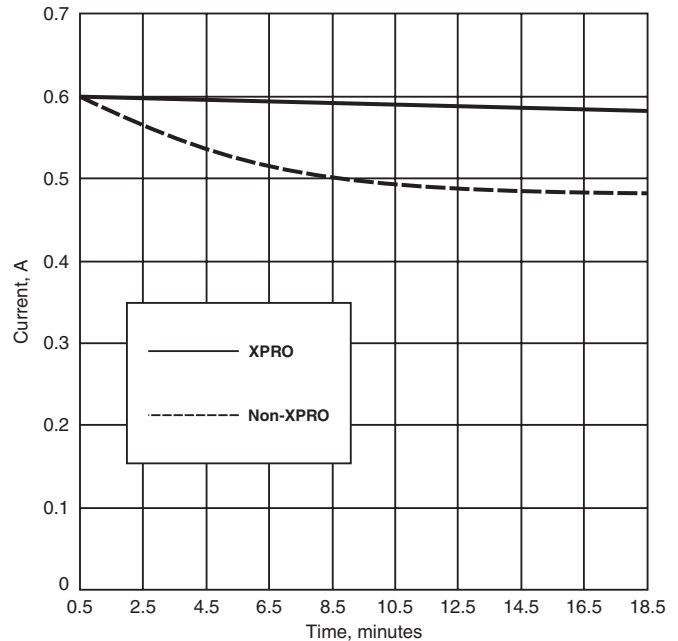

Application

For use with most proportional valves. GP, HP, JP, GTP and AP series valves.

Dimensions Millimeters (Inches)

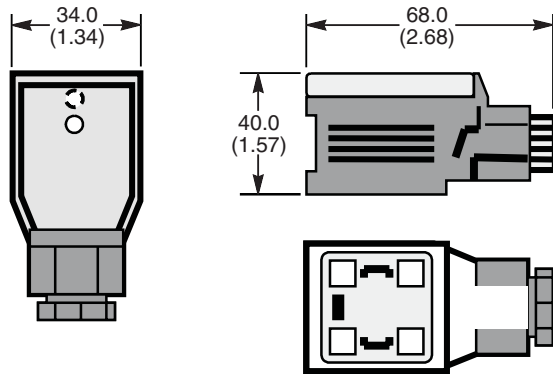

Ordering Information



Code	Maximum Current
902	1.6A
932	2.6A
904	1.0A
934	1.4A

Connection Details

XPRO902 and XPRO932

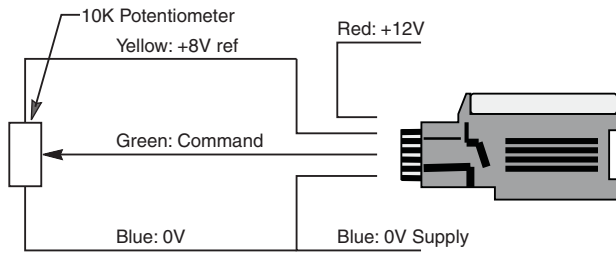

XPRO904 and XPRO934

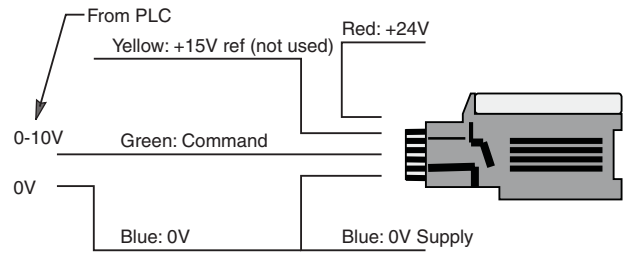
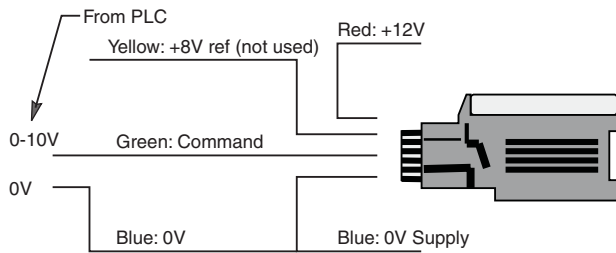
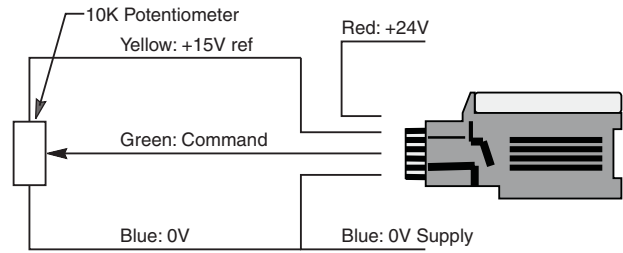

Controller / Coil Combination

Coil	Controller	
	XPRO 902	XPRO 932
CCS012D	X	
CCP012D	X	
CAS012D	X	
CAP012D		X

Coil	Controller	
	XPRO 904	XPRO 934
CCS024D	X	
CCP024D	X	
CAS024D	X	
CAP024D		X

- CV** Check Valves
- SH** Shuttle Valves
- LM** Load/Motor Controls
- FC** Flow Controls
- PC** Pressure Controls
- LE** Logic Elements
- DC** Directional Controls
- MV** Manual Valves
- SV** Solenoid Valves
- PV** Proportional Valves
- CE** Coils & Electronics
- BC** Bodies & Cavities
- TD** Technical Data

Technical Information

- CV** Check Valves
- SH** Shuttle Valves
- LM** Load/Motor Controls
- FC** Flow Controls
- PC** Pressure Controls
- LE** Logic Elements
- DC** Directional Controls
- MV** Manual Valves
- SV** Solenoid Valves
- PV** Proportional Valves
- CE** Coils & Electronics
- BC** Bodies & Cavities
- TD** Technical Data

General Description

Proportional Valve Controllers. 12 and 24 Volts, PWM with Adjustable Dither. For additional information see Technical Tips on pages CE1-CE2.

Operation

The 902d/932d and 904d/934d are valve top mounted PWM controllers for proportional control valves. They can be used with an external potentiometer to give accurate current control using the units internal reference voltage. Alternatively these controllers can be used with a 0-10V command signal from a PLC or engine management system.

'I Max' adjustment is provided to allow the maximum output current to be set via a 12 turn potentiometer. Turn clockwise to increase the output current.

Dither adjustment POT is used to alter the PWM frequency of the controller from 95 HZ to 230 Hz. By changing the frequency this pot controls the amount of dither imposed on the valve. Lower frequency = more dither, higher frequency = less dither. Turn clockwise to increase frequency.

Notes:

XPRO902d and XPRO932d

In order to avoid damaging a controller the +8V (yellow) lead must not be shorted to the +12V (red) lead or to the 0V (blue) lead.

XPRO904d and XPRO934d

In order to avoid damaging a controller the +15V (yellow) lead must not be shorted to the +24V (red) lead or to the 0V (blue) lead.

Specifications

Nominal Voltage	XPRO902d	12V DC
	XPRO932d	12V DC
	XPRO904d	24V DC
	XPRO934d	24V DC
Maximum Power	XPRO902d	19W
	XPRO932d	30W
	XPRO904d	19W
	XPRO934d	30W
(IP) Rating	IP 65	
Maximum Current	XPRO902d	1.6A
	XPRO932d	2.6A
	XPRO904d	1.0A
	XPRO934d	1.4A
Command Voltage	0 - 10V	
Input Resistance	10K ohms	
Reference Voltage	XPRO902d	+8V (2mA)
	XPRO932d	+8V (2mA)
	XPRO904d	+15V (2mA)
	XPRO934d	+15V (2mA)
Cable Length	1 meter	
Frequency	95 Hz - 230 Hz	

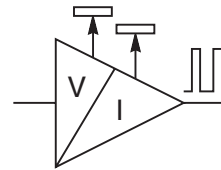
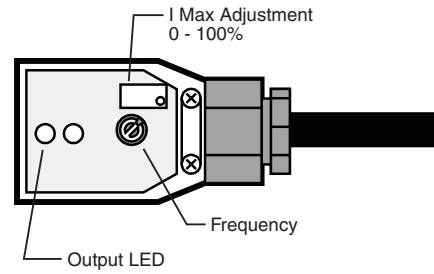

Features

- Self contained DIN 'Plug Top'
- High impact resistant molded ABS
- Complies with current CE regulations

Output Regulation

(Curve shows coil temperature compensation)

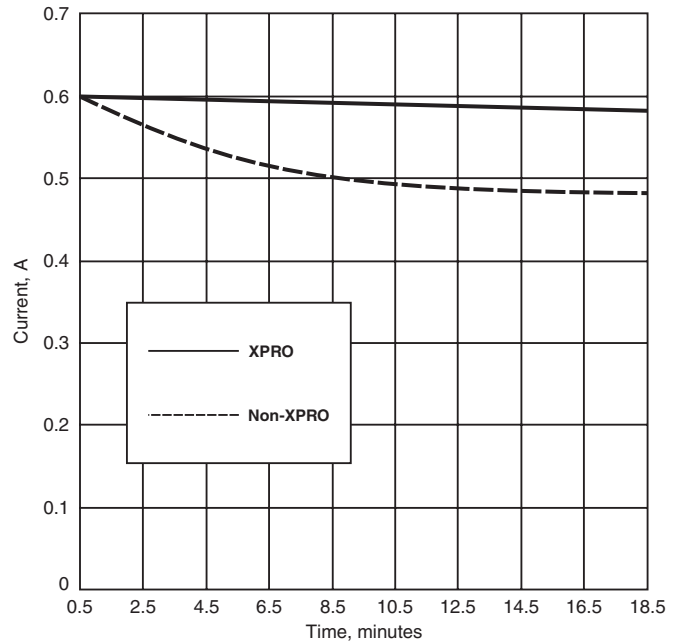

Application

For use with most proportional valves. GP, HP, JP, GTP and AP series valves.

Dimensions Millimeters (Inches)

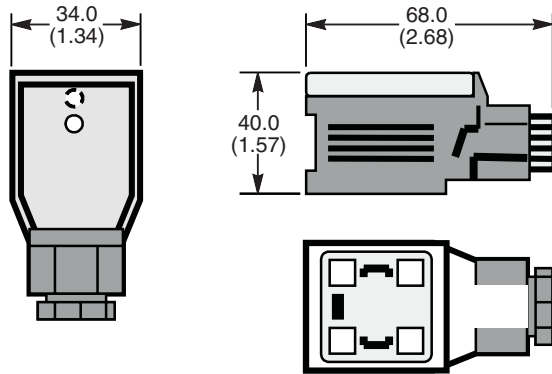

Ordering Information



Code	Maximum Current
902d	1.6A
932d	2.6A
904d	1.0A
934d	1.4A

Setting for standard:
 Dither frequency: 110 HZ

Connection Details

XPRO902d and XPRO932d

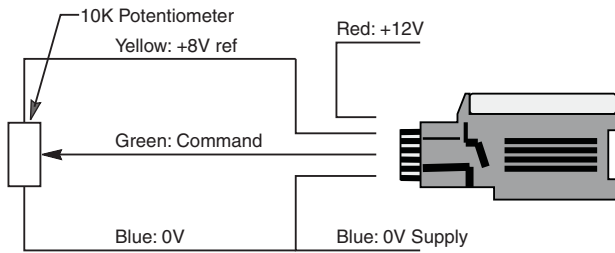

XPRO904d and XPRO934d

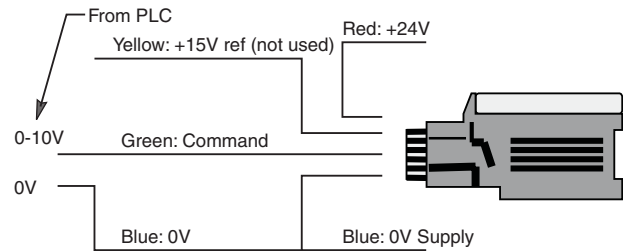
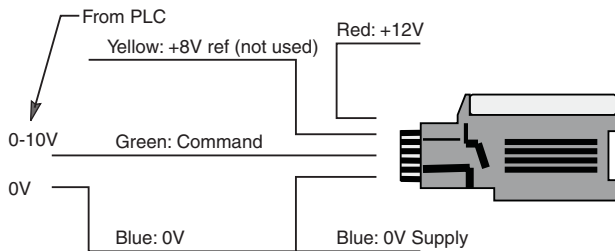
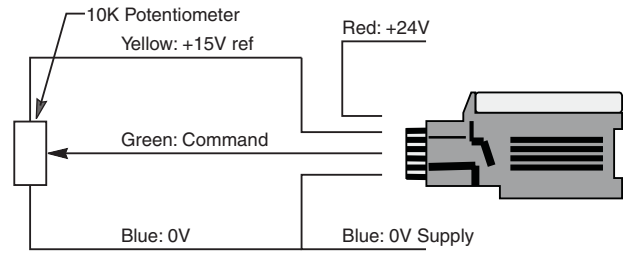

Controller / Coil Combination

Coil	Controller	
	XPRO 902d	XPRO 932d
CCS012D	X	
CCP012D	X	
CAS012D	X	
CAP012D		X

Coil	Controller	
	XPRO 904d	XPRO 934d
CCS024D	X	
CCP024D	X	
CAS024D	X	
CAP024D		X

CV
Check Valves
SH
Shuttle Valves
LM
Load/Motor Controls
FC
Flow Controls
PC
Pressure Controls
LE
Logic Elements
DC
Directional Controls
MV
Manual Valves
SV
Solenoid Valves
PV
Proportional Valves
CE
Coils & Electronics
BC
Bodies & Cavities
TD
Technical Data

General Description

Proportional Valve Controllers. 12 and 24 Volts, PWM with Multiple Adjustments. For additional information see Technical Tips on pages CE1-CE2.

Operation

The 902rid/932rid and 904rid/934rid are valve top mounted PWM controllers for proportional control valves. They can be used with an external potentiometer to give accurate current control using the units internal reference voltage. Alternatively these controllers can be used with a 0-10V command signal from a PLC or engine management system.

'I' Max adjustment is provided to allow the maximum output current to be set via a 12 turn potentiometer. Turn clockwise to increase the output current.

Ramp Up and Ramp Down adjustments provide independent, linear control of the time it takes, to reach 'I' Max and to switch off, up to 8 seconds of delay. Turn clockwise for slower ramps.

'I' Min adjustment Pot sets the minimum current the controller will jump to when a command signal is present, used to eliminate dead band in a slow ramp. Turn clockwise for a higher 'I' Min setting.

Dither adjustment Pot is used to alter the PWM frequency of the controller from 95 HZ to 230 HZ. By changing the frequency this pot controls the amount of dither imposed on the valve. Lower frequency = more dither, higher frequency = less dither. Turn clockwise to increase frequency.

Notes:

XPRO902rid and XPRO932rid

In order to avoid damaging a controller the +8V (yellow) lead must not be shorted to the +12V (red) lead or to the 0V (blue) lead.

XPRO904rid and XPRO934rid

In order to avoid damaging a controller the +15V (yellow) lead must not be shorted to the +24V (red) lead or to the 0V (blue) lead.

Specifications

Nominal Voltage	XPRO902rid & 932rid 12V DC XPRO904rid & 934rid 24V DC
Maximum Power	XPRO902rid & 904rid 19W XPRO932rid & 934rid 30W
(IP) Rating	IP 65
Maximum Current	XPRO902rid 1.6A XPRO932rid 2.6A XPRO904rid 1.0A XPRO934rid 1.4A
Command Voltage	0 - 10V
Input Resistance	10K ohms
Reference Voltage	XPRO902rid & 932rid +8V (2mA) XPRO904rid & 934rid +15V (2mA)
Cable Length	1 meter
Ramp Up/Down	200ms - 8s

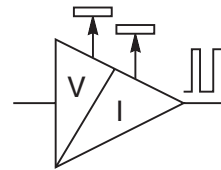
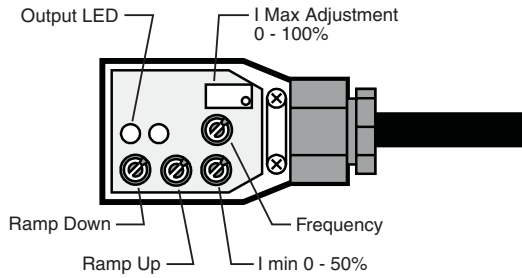

Features

- Self contained DIN 'Plug Top'
- High impact resistant molded ABS
- Complies with current CE regulations

Output Regulation

(Curve shows coil temperature compensation)

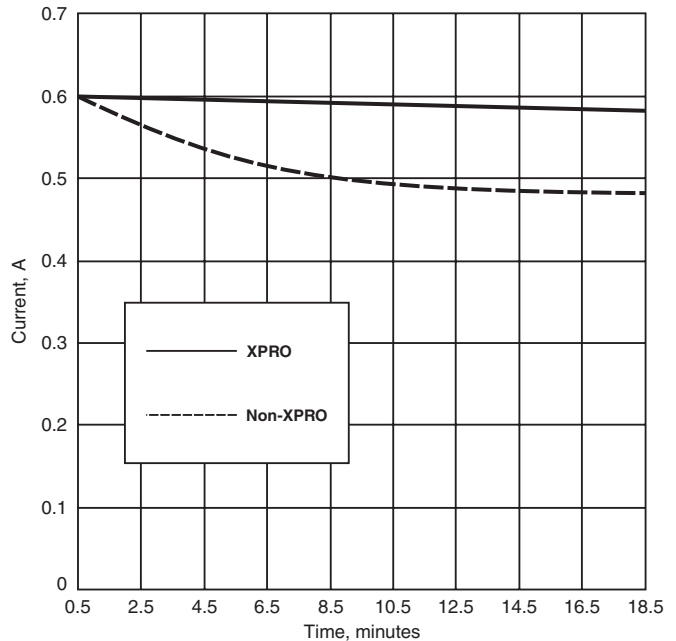

Application

For use with most proportional valves. GP, HP, JP, GTP and AP series valves.

Dimensions Millimeters (Inches)

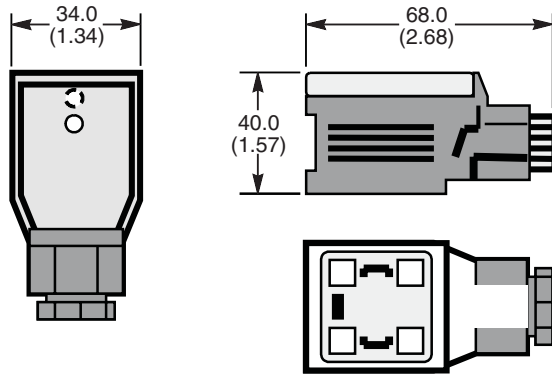

Ordering Information



Code	Maximum Current
902rid	1.6A
932rid	2.6A
904rid	1.0A
934rid	1.4A

Setting for standard:
 Dither frequency: 110 HZ

Connection Details

XPRO902rid and XPRO932rid

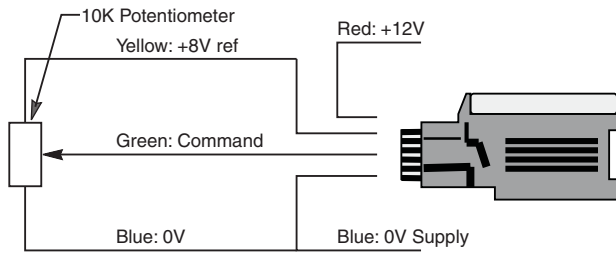

XPRO904rid and XPRO934rid

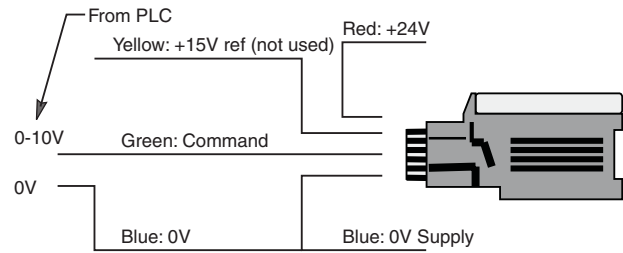
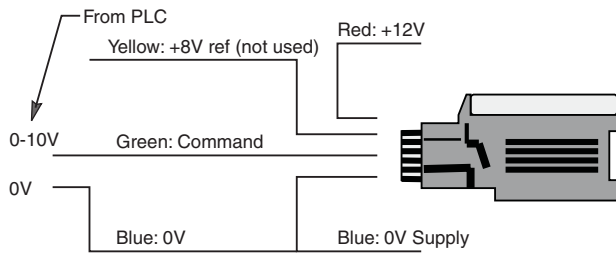
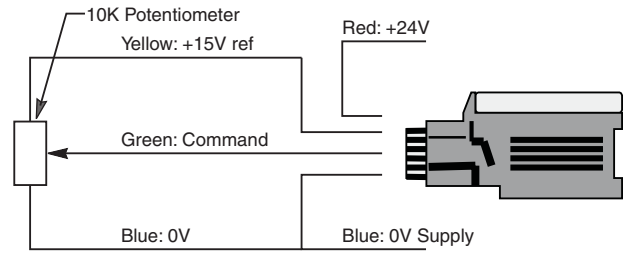

Controller / Coil Combination

Coil	Controller	
	XPRO 902rid	XPRO 932rid
CCS012D	X	
CCP012D	X	
CAS012D	X	
CAP012D		X

Coil	Controller	
	XPRO 904rid	XPRO 934rid
CCS024D	X	
CCP024D	X	
CAS024D	X	
CAP024D		X

Technical Information

- CV** Check Valves
- SH** Shuttle Valves
- LM** Load/Motor Controls
- FC** Flow Controls
- PC** Pressure Controls
- LE** Logic Elements
- DC** Directional Controls
- MV** Manual Valves
- SV** Solenoid Valves
- PV** Proportional Valves
- CE** Coils & Electronics
- BC** Bodies & Cavities
- TD** Technical Data

General Description

Soft Start Valve Controller. 12 and 24 Volt PWM. For additional information see Technical Tips on pages CE1-CE2.

Features

- Self contained DIN PWM 'Plug Top'
- High impact resistant moulded ABS
- Supplied with approximately 1 meter of two color coded cables
- Can be used with 12V DC and 24V DC coils
- Fixed 1-second ramp upon engagement

Operation

The 704 is a soft start plug top PWM controller used for reducing the hydraulic pressure peaks produced when a hydraulic valve is operated. It can simply be used in place of a standard DIN connector.

Output Voltage

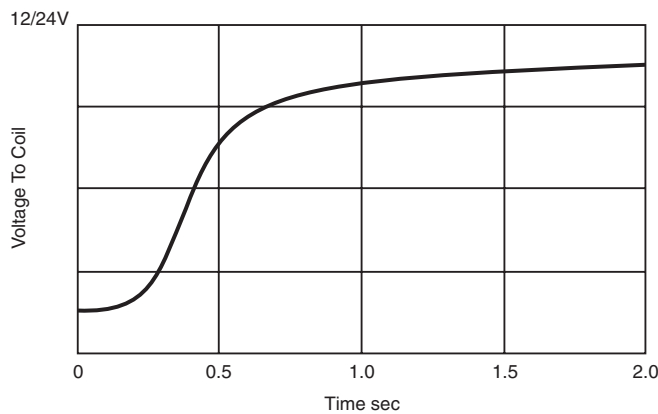

Application

For use with most proportional valves. GP, HP, JP, GTP and AP series valves.

Specifications

Nominal Voltage	12V DC and 24V DC
Maximum Power	36W
(IP) Rating	IP 65
Maximum Current	3.0A
Coil Resistance	4.5 - 30 ohms
Ramp Up	Fixed 1000ms

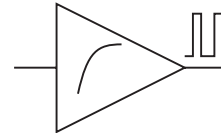
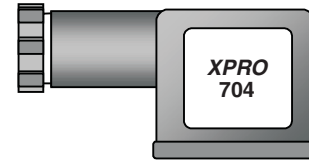

Dimensions Millimeters (Inches)

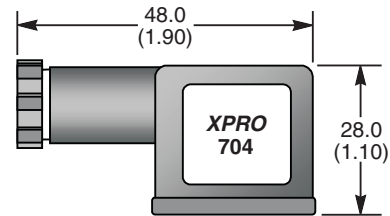

Connection Details

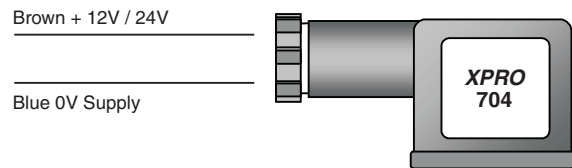

Controller / Coil Combination

XPRO 704 can be used with all 12V DC and 24V DC DIN coils.

Ordering Information

XPRO	704
Controller	Plug Type
Code	Plug Type
704	Soft Start

General Description

Soft Start/Stop Valve Controller. 12 and 24 Volts, PWM with Adjustable Ramps. For additional information see Technical Tips on pages CE1-CE2.

Features

- Adjustable ramp to engage and disengage
- Self contained DIN 'Plug Top'
- High impact resistant moulded ABS

Operation

The 704b is a valve top mounted 'soft start, soft stop' controller for use with a range of valves.

The controller can be set to jump to a preset 'step' voltage then ramp up to maximum at a preset rate. It can also be set to jump down to a preset 'step' voltage and ramp down to zero. This can be used to eliminate 'bangs' or hydraulic shocks associated with operating a hydraulic valve.

Output Voltage

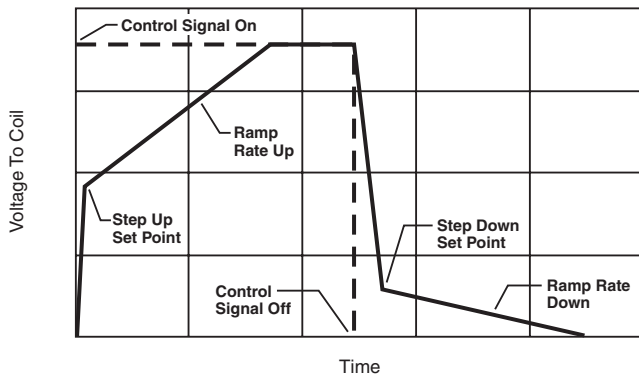

Application

For use with most proportional valves. GP, HP, JP, GTP and AP series valves.

Specifications

Nominal Voltage	12V DC and 24V DC
Maximum Power	36W
(IP) Rating	IP 65
Maximum Current	3.0A
Coil Resistance	4.8 - 30 ohms
Coil Voltage	+V Supply
Control Resistance	820 ohms
Cable Length	1 meter
Step Up Adjust	10 - 80%
Step Down Adjust	10 - 80%
Ramp Up/Down	200ms - 4s

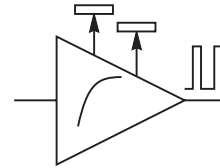
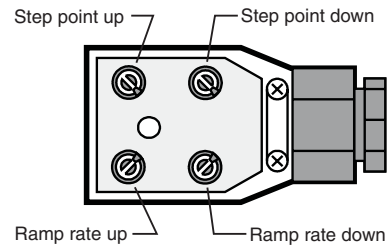

Dimensions Millimeters (Inches)

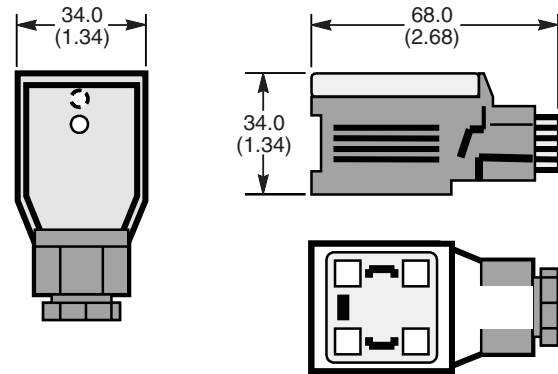

Connection Details

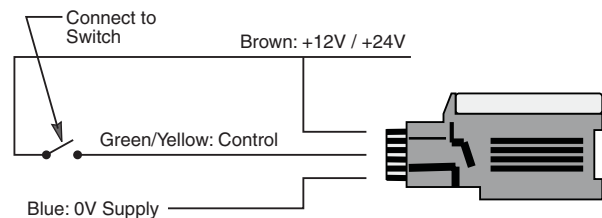

Controller / Coil Combination

XPRO 704b can be used with all 12V DC and 24V DC DIN coils.

Ordering Information

XPRO	704b
Controller	Plug Type
Code	Plug Type
704b	Soft Start, Soft Stop

CV

Check Valves

SH

Shuttle Valves

LM

Load/Motor Controls

FC

Flow Controls

PC

Pressure Controls

LE

Logic Elements

DC

Directional Controls

MV

Manual Valves

SV

Solenoid Valves

PV

Proportional Valves

CE

Coils & Electronics

BC

Bodies & Cavities

TD

Technical Data

Technical Information

- CV** Check Valves
- SH** Shuttle Valves
- LM** Load/Motor Controls
- FC** Flow Controls
- PC** Pressure Controls
- LE** Logic Elements
- DC** Directional Controls
- MV** Manual Valves
- SV** Solenoid Valves
- PV** Proportional Valves
- CE** Coils & Electronics
- BC** Bodies & Cavities
- TD** Technical Data

General Description

Power Saver Controller. 12 and 24 Volt, PWM. For additional information see Technical Tips on pages CE1-CE2.

Features

- Reduced power consumption and heat generation
- Self contained DIN 'Plug Top'
- High impact resistant moulded ABS
- Supplied with approximately 1 meter of two color coded cables

Operation

The 804 is a power saver plug top PWM controller used for reducing the current consumption of a standard on/off valve. The plug will deliver full voltage to the valve for 50mS then drop down to a holding voltage of 30% of the applied voltage. This can be used where multiple valves are used and power consumption is a consideration. It can simply be used in place of a standard DIN connector.

Voltage Applied To Coil

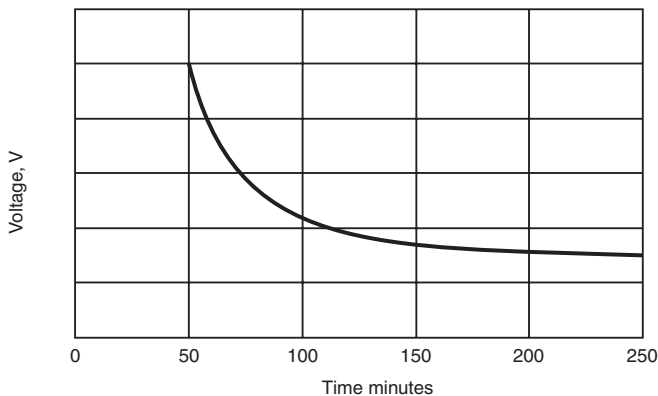

Application

For use with most on/off valves. GO, GS series valves.

Specifications

Nominal Voltage	12V DC and 24V DC
Maximum Power	36W
(IP) Rating	IP 65
Maximum Current	3.0A
Coil Resistance	4.5 - 30 ohms
Current Reduction	30% of Max

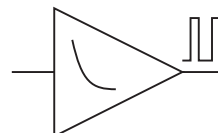
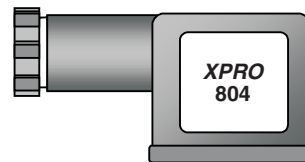

Dimensions Millimeters (Inches)

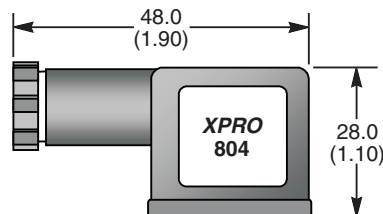

Connection Details

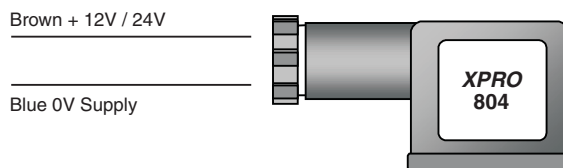

Controller / Coil Combination

XPRO 804 can be used with all 12V DC and 24V DC coils.

Ordering Information

XPRO	804
Controller	Plug Type
Code	Plug Type
804	Power Saver Plug

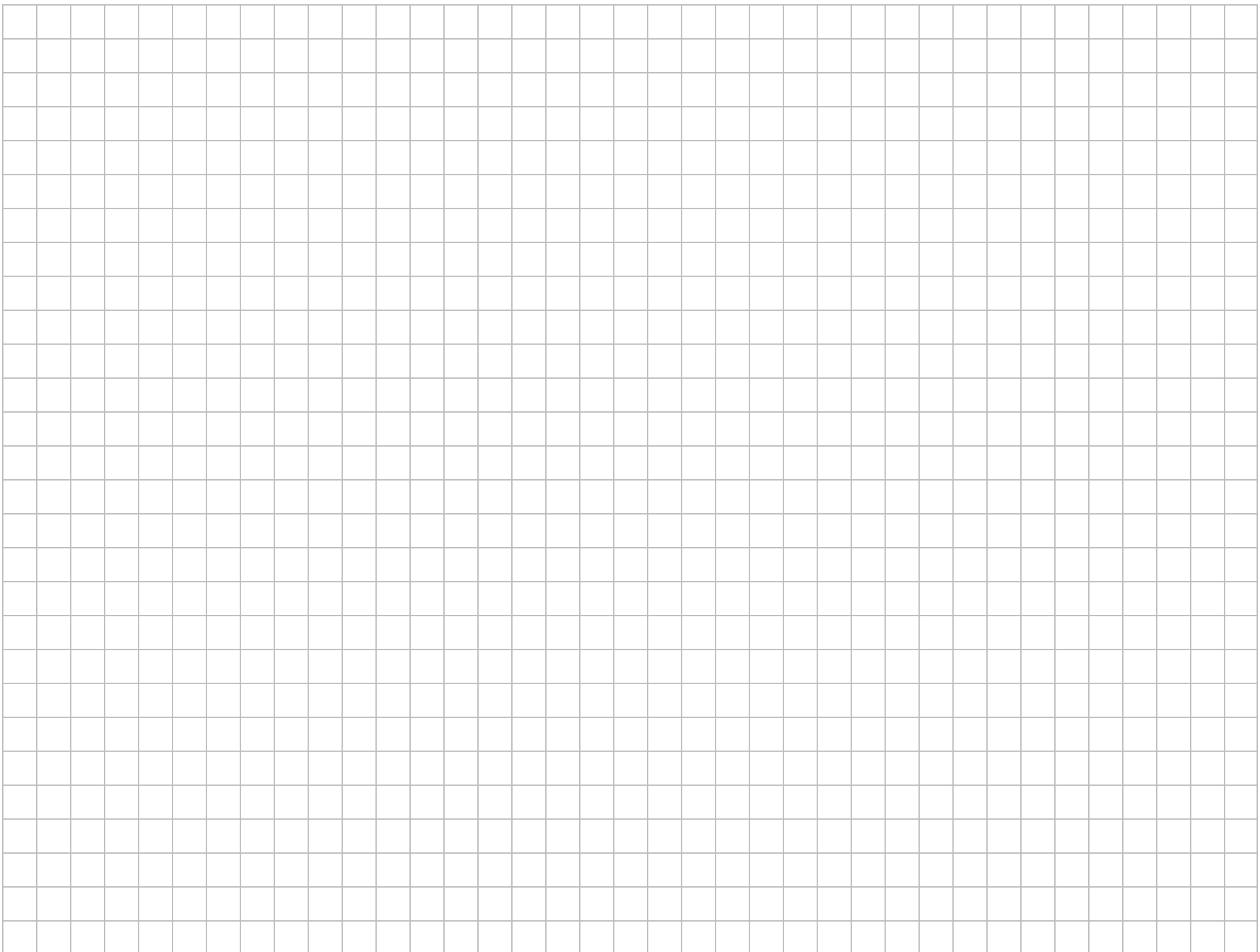





CE26

Parker Hannifin Corporation
Hydraulic Cartridge Systems

Technical Data	TD	Bodies & Cavities	BC	Coils & Electronics	CE	Proportional Valves	PV	Solenoid Valves	SV	Manual Valves	MV	Directional Controls	DC	Logic Elements	LE	Pressure Controls	PC	Flow Controls	FC	Load/Motor Controls	LM	Shuttle Valves	SH	Check Valves	CV
----------------	-----------	-------------------	-----------	--------------------------------	-----------	---------------------	-----------	-----------------	-----------	---------------	-----------	----------------------	-----------	----------------	-----------	-------------------	-----------	---------------	-----------	---------------------	-----------	----------------	-----------	--------------	-----------

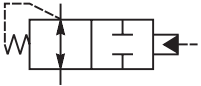
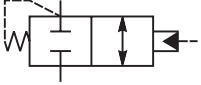
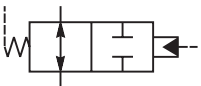
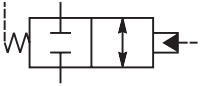
Contents

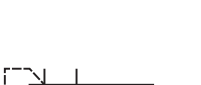
Directional Control Valves

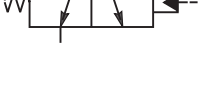
	SERIES	CAVITY	DESCRIPTION	FLOW LPM/GPM	PRESSURE BAR/PSI	PAGE NO.
	R04C3	C10-3	2 Way, Normally Open, Pilot to Close	80/21	420/6000	DC1-DC2
	R04D3	C10-3	2 Way, Normally Closed, Pilot to Open	100/26	420/6000	DC3
	R04A4	C10-4	2 Way, Normally Open, Pilot to Close, External Vent	80/21	420/6000	DC4
	R04B4	C10-4	2 Way, Normally Closed, Pilot to Open, External Vent	80/21	420/6000	DC5
	DH103	C10-4	3 Way, External Pilot, Normally Open, Vent to Atmosphere	38/10	240/3500	DC7-DC8
	N04A4	C10-4	3 Way, Internal Vent, External Pilot	90/24	420/6000	DC9
	N04B4	C10-4	3 Way, Internal Vent, External Pilot	90/24	420/6000	DC10
	N04G4	C10-4	3 Way, Vent to Atmosphere, External Pilot	85/22	420/6000	DC11
	N04H4	C10-4	3 Way, Vent to Atmosphere, External Pilot	85/22	420/6000	DC12
	N5A125	5A	3 Way, 2 Position, External Drain, Open Transition	160/42	420/6000	DC13
	N5A300	100-1	3 Way, 2 Position, External Drain, Open Transition	400/105	420/6000	DC14
	N5B125	5A	3 Way, 2 Position, External Drain, Closed Transition	160/42	420/6000	DC15
	N5B300	100-1	3 Way, 2 Position, External Drain, Closed Transition	400/105	420/6000	DC16
	N5C125	5A	3 Way, 2 Position, External Drain, Diverter Valve, Normally Open	160/42	420/6000	DC17
	N5C300	100-1	3 Way, 2 Position, External Drain, Diverter Valve, Normally Open	400/105	420/6000	DC18
	N5D125	5A	3 Way, 2 Position, External Drain, Diverter Valve, Normally Closed	160/42	420/6000	DC19
	N5D300	100-1	3 Way, 2 Position, External Drain, Diverter Valve, Normally Closed	400/105	420/6000	DC20

- CV**
Check Valves
- SH**
Shuttle Valves
- LM**
Load/Motor Controls
- FC**
Flow Controls
- PC**
Pressure Controls
- LE**
Logic Elements
- DC**
Directional Controls
- MV**
Manual Valves
- SV**
Solenoid Valves
- PV**
Proportional Valves
- CE**
Coils & Electronics
- BC**
Bodies & Cavities
- TD**
Technical Data



Technical Information

- CV** Check Valves
- SH** Shuttle Valves
- LM** Load/Motor Controls
- FC** Flow Controls
- PC** Pressure Controls
- LE** Logic Elements
- DC** Directional Controls
- MV** Manual Valves
- SV** Solenoid Valves
- PV** Proportional Valves
- CE** Coils & Electronics
- BC** Bodies & Cavities
- TD** Technical Data

General Description

Diverter Valve, Normally Open, Pilot to Close Vent and Pressure Compensating Flow Control Element.

Features

- Two switching and one compensating spring available
- Very accurate flow regulation when used with separate orifice
- Sealed pilot option available
- Industry common cavity
- Hardened working parts for maximum durability
- All external parts zinc plated

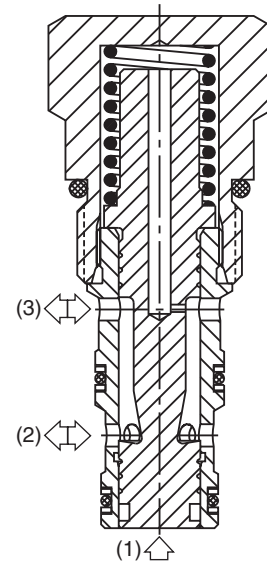
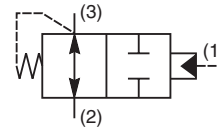
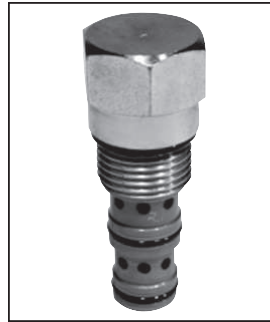

Specifications

Rated Flow	80 LPM (21 GPM)
Nominal Flow @ 7 Bar (100 PSI)	Diverter - 40 LPM (10 GPM) Compensator - See Application
Maximum Inlet Pressure	420 Bar (6000 PSI)
Pilot Switching Pressure	See ordering information
Cartridge Material	All parts steel. All operating parts hardened steel.
Operating Temp. Range/Seals	-40°C to +93.3°C (Nitrile, Buna-N) (-40°F to +200°F) -31.7°C to +121.1°C (Fluorocarbon) (-25°F to +250°F)
Fluid Compatibility/Viscosity	Mineral-based or synthetic with lubricating properties at viscosities of 45 to 2000 SSU (6 to 420 cSt)
Filtration	ISO code 16/13, SAE Class 4 or better
Approx. Weight	.15 kg (.33 lbs.)
Cavity	C10-3 (See BC Section for more details)

Performance Curve

Diverting Pressure Drop (Through cartridge only)

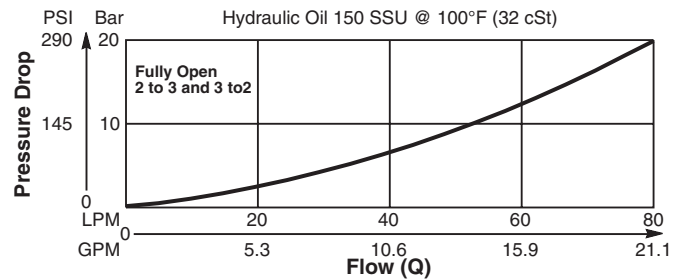

Application

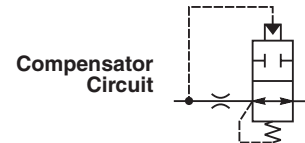

Compensating Flow Regulation Performance 3 to 2

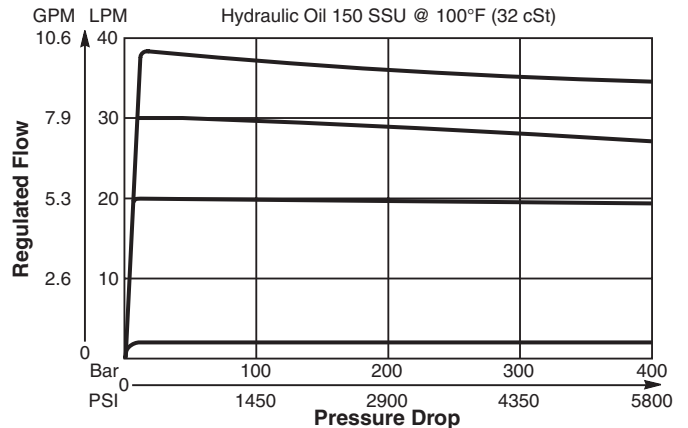

Dimensions Millimeters (Inches)

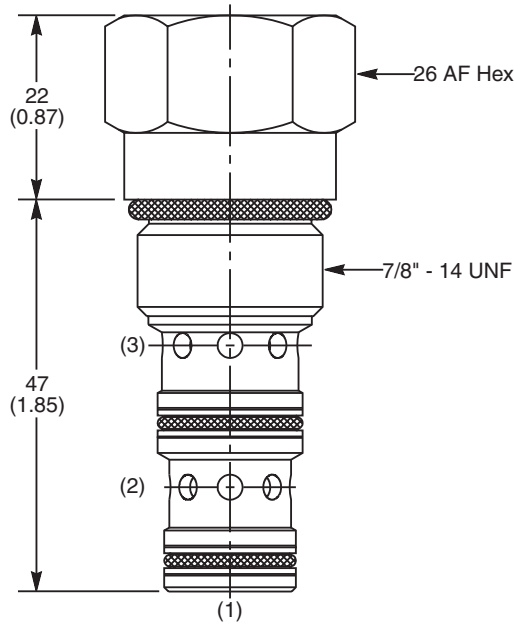

Ordering Information

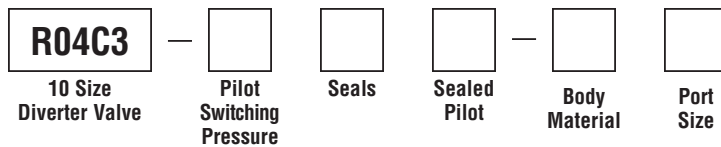

Code	Switching Pressure
For Switching	
5.0	5.0 Bar (73 PSI) Std.
10.0	10.0 Bar (145 PSI)
For Flow Regulation	
7.7	7.7 Bar (112 PSI)

If no switching pressure is specified, valve will be supplied as R04C3-5.0N

Code	Sealed Pilot
Omit	If not required
S	Sealed Pilot

Code	Body Material
Omit	Steel
A	Aluminum

Code	Port Size	Body Part No.
Omit	Cartridge Only	
4P	1/4" NPTF	(B10-3-*4P)
6P	3/8" NPTF	(B10-3-*6P)
8P	1/2" NPTF	(B10-3-*8P)
6T	SAE-6	(B10-3-*6T)
8T	SAE-8	(B10-3-*8T)
6B	3/8" BSPG	(B10-3-6B)†
8B	1/2" BSPG	(B10-3-*8B)

** Add "A" for aluminum, omit for steel.
 † Steel bodies only.*

Code	Seals / Kit No.
N	Nitrile, Buna-N / (SK30505N-1)
V	Fluorocarbon / (SK30505V-1)

- CV**
Check Valves
- SH**
Shuttle Valves
- LM**
Load/Motor Controls
- FC**
Flow Controls
- PC**
Pressure Controls
- LE**
Logic Elements
- DC**
Directional Controls
- MV**
Manual Valves
- SV**
Solenoid Valves
- PV**
Proportional Valves
- CE**
Coils & Electronics
- BC**
Bodies & Cavities
- TD**
Technical Data

- CV** Check Valves
- SH** Shuttle Valves
- LM** Load/Motor Controls
- FC** Flow Controls
- PC** Pressure Controls
- LE** Logic Elements
- DC** Directional Controls
- MV** Manual Valves
- SV** Solenoid Valves
- PV** Proportional Valves
- CE** Coils & Electronics
- BC** Bodies & Cavities
- TD** Technical Data

General Description

Diverter Valve, Normally Closed, Pilot to Open.

Features

- Two switching pressures available
- Sealed pilot option available
- Hardened working parts for maximum durability
- All external parts zinc plated

Performance Curve

Pressure Drop vs. Flow (Through cartridge only)

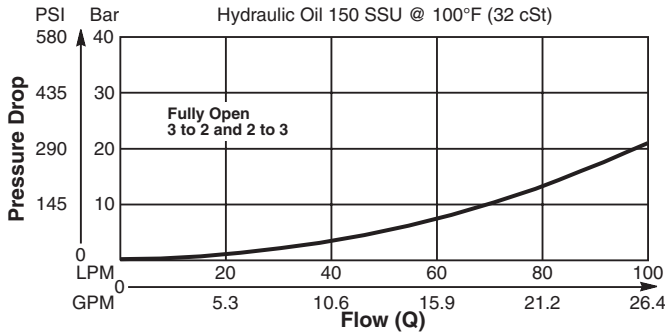

Application Note

To fully open, the valve requires at least a further 2 Bar (29 PSI) above the pilot switching pressure.

Specifications

Rated Flow	100 LPM (22 GPM)
Nominal Flow @ 7 Bar (100 PSI)	60 LPM (16 GPM)
Maximum Inlet Pressure	420 Bar (6000 PSI)
Pilot Switching Pressure	See ordering information
Cartridge Material	All parts steel. All operating parts hardened steel.
Operating Temp. Range/Seals	-40°C to +93.3°C (Nitrile, Buna-N) (-40°F to +200°F) -31.7°C to +121.1°C (Fluorocarbon) (-25°F to +250°F)
Fluid Compatibility/Viscosity	Mineral-based or synthetic with lubricating properties at viscosities of 45 to 2000 SSU (6 to 420 cSt)
Filtration	ISO code 16/13, SAE Class 4 or better
Approx. Weight	.15 kg (.33 lbs.)
Cavity	C10-3 (See BC Section for more details)

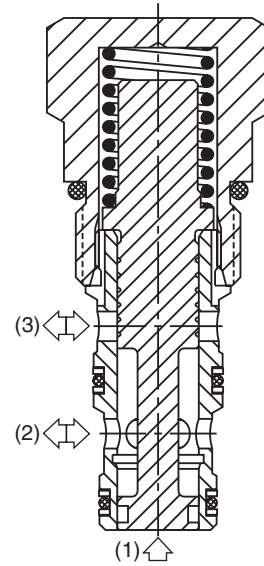
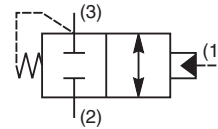
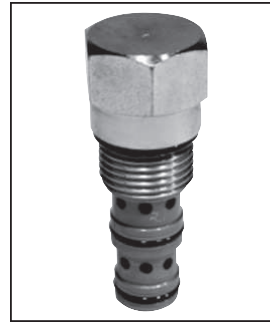

Dimensions

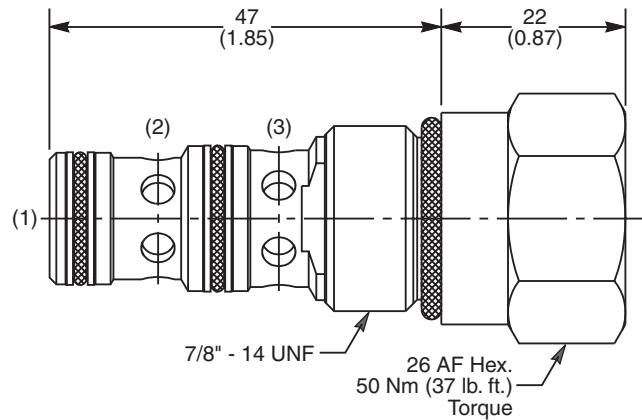

Ordering Information

R04D3					
10 Size Diverter Valve	Pilot Switching Pressure	Seals	Sealed Pilot	Body Material	Port Size

Code	Switching Pressure
5.0	5.0 Bar (73 PSI) Std.
10.0	10.0 Bar (145 PSI)

If no switching pressure is specified, valve will be supplied as R04D3-5.0N

Code	Body Material
Omit	Steel
A	Aluminum

Code	Seals / Kit No.
N	Nitrile, Buna-N / (SK30505N-1)
V	Fluorocarbon / (SK30505V-1)

Code	Sealed Pilot
Omit	If not required
S	Sealed Pilot

Code	Port Size	Body Part No.
Omit	Cartridge Only	
4P	1/4" NPTF	(B10-3-*4P)
6P	3/8" NPTF	(B10-3-*6P)
8P	1/2" NPTF	(B10-3-*8P)
6T	SAE-6	(B10-3-*6T)
8T	SAE-8	(B10-3-*8T)
6B	3/8" BSPG	(B10-3-6B)†
8B	1/2" BSPG	(B10-3-*8B)

* Add "A" for aluminum, omit for steel.
 † Steel bodies only.

General Description

Diverter Valve, Normally Open, 2-Way with External Pilot and Vent.

Features

- High flow capacity
- Two switching pressures
- Sealed pilot option available
- Hardened working parts for maximum durability
- All external parts zinc plated

Performance Curve

Pressure Drop vs. Flow (Through cartridge only)

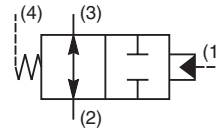
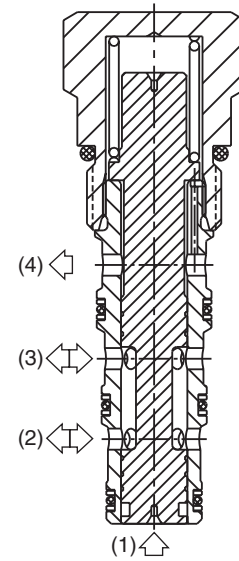
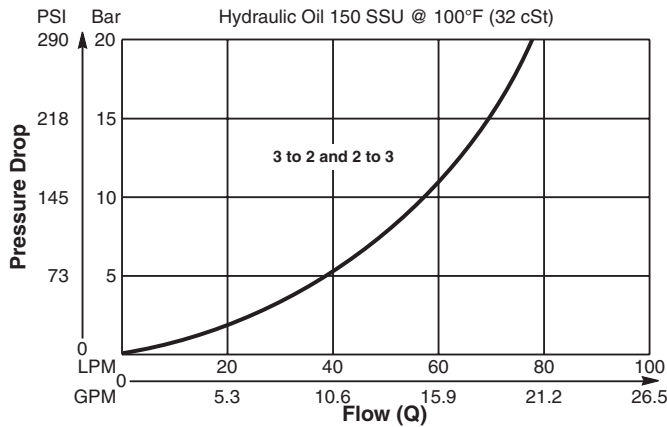

Dimensions Millimeters (Inches)

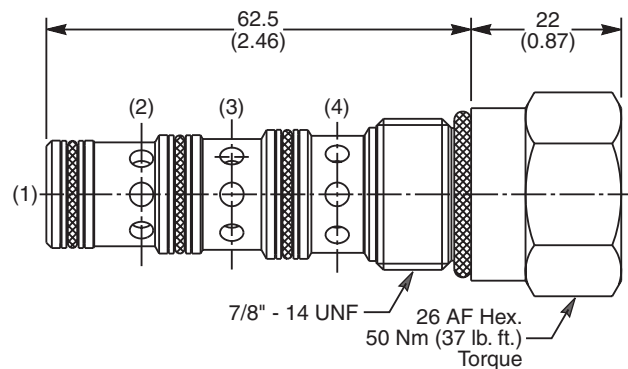

Specifications

Rated Flow	80 LPM (21 GPM)
Nominal Flow @ 7 Bar (100 PSI)	47 LPM (12 GPM)
Maximum Inlet Pressure	420 Bar (6000 PSI)
Pilot Switching Pressure	See ordering information
Cartridge Material	All parts steel. All operating parts hardened steel.
Operating Temp. Range/Seals	-40°C to +93.3°C (Nitrile, Buna-N) (-40°F to +200°F) -31.7°C to +121.1°C (Fluorocarbon) (-25°F to +250°F)
Fluid Compatibility/Viscosity	Mineral-based or synthetic with lubricating properties at viscosities of 45 to 2000 SSU (6 to 420 cSt)
Filtration	ISO code 16/13, SAE Class 4 or better
Approx. Weight	.17 kg (.37 lbs.)
Cavity	C10-4 (See BC Section for more details)

Ordering Information

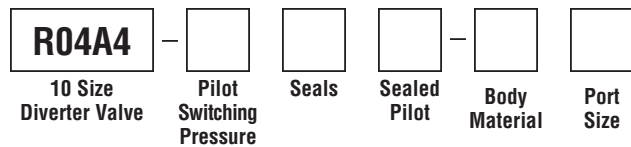

Code	Switching Pressure
5.0	5.0 Bar (73 PSI) Std.
10.0	10.0 Bar (145 PSI)

If no switching pressure is specified, valve will be supplied as R04A4-5.0N

Code	Seals / Kit No.
N	Nitrile, Buna-N / (SK30506N-1)
V	Fluorocarbon / (SK30506V-1)

Code	Sealed Pilot
Omit	If not required
S	Sealed Pilot

Code	Body Material
Omit	Steel
A	Aluminum

Code	Port Size	Body Part No.
Omit	Cartridge Only	
6P	3/8" NTPF	(B10-4-*6P)
6T	SAE-6	(B10-4-*6T)
8T	SAE-8	(B10-4-*8T)
6B	3/8" BSPG	(B10-4-6B)†

** Add "A" for aluminum, omit for steel.
 † Steel bodies only*

- CV** Check Valves
- SH** Shuttle Valves
- LM** Load/Motor Controls
- FC** Flow Controls
- PC** Pressure Controls
- LE** Logic Elements
- DC** Directional Controls
- MV** Manual Valves
- SV** Solenoid Valves
- PV** Proportional Valves
- CE** Coils & Electronics
- BC** Bodies & Cavities
- TD** Technical Data

- CV** Check Valves
- SH** Shuttle Valves
- LM** Load/Motor Controls
- FC** Flow Controls
- PC** Pressure Controls
- LE** Logic Elements
- DC** Directional Controls
- MV** Manual Valves
- SV** Solenoid Valves
- PV** Proportional Valves
- CE** Coils & Electronics
- BC** Bodies & Cavities
- TD** Technical Data

General Description

Diverter Valve, Normally Closed, 2-Way with External Pilot and Vent.

Features

- High flow capacity
- Two switching pressures available
- Sealed pilot option available
- Hardened working parts for maximum durability
- All external parts zinc plated

Performance Curve

Pressure Drop vs. Flow (Through cartridge only)

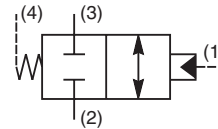
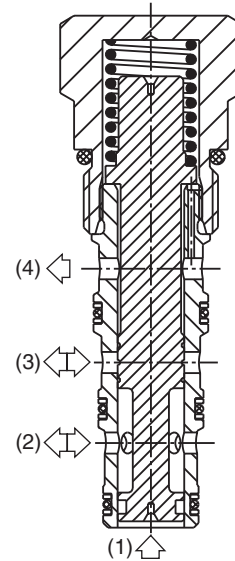
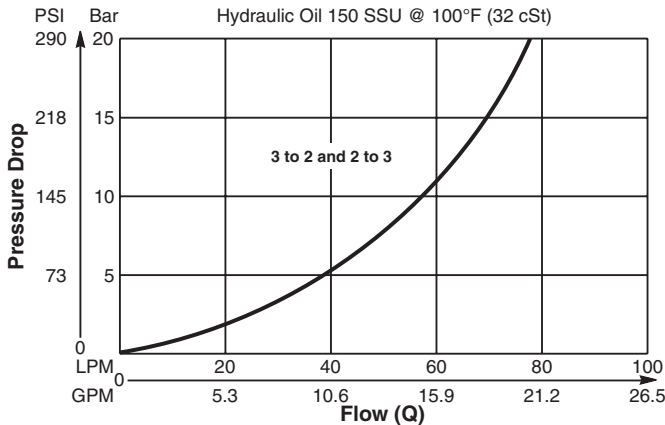

Dimensions

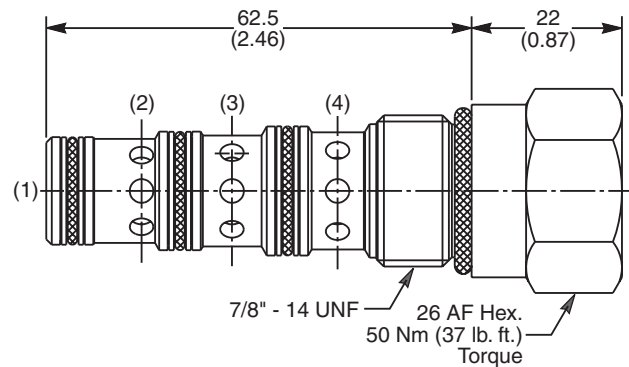

Specifications

Rated Flow	80 LPM (21 GPM)
Nominal Flow @ 7 Bar (100 PSI)	47 LPM (12 GPM)
Maximum Inlet Pressure	420 Bar (6000 PSI)
Pilot Switching Pressure	See ordering information
Cartridge Material	All parts steel. All operating parts hardened steel.
Operating Temp. Range/Seals	-40°C to +93.3°C (Nitrile, Buna-N) (-40°F to +200°F) -31.7°C to +121.1°C (Fluorocarbon) (-25°F to +250°F)
Fluid Compatibility/Viscosity	Mineral-based or synthetic with lubricating properties at viscosities of 45 to 2000 SSU (6 to 420 cSt)
Filtration	ISO code 16/13, SAE Class 4 or better
Approx. Weight	.17 kg (.37 lbs.)
Cavity	C10-4 (See BC Section for more details)

Ordering Information

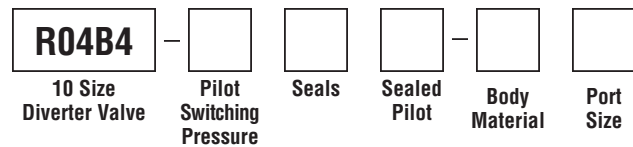

Code	Switching Pressure
5.0	5.0 Bar (73 PSI) Std.
10.0	10.0 Bar (145 PSI)

If no switching pressure is specified, valve will be supplied as R04B4-5.0N

Code	Body Material
Omit	Steel
A	Aluminum

Code	Seals / Kit No.
N	Nitrile, Buna-N / (SK30506N-1)
V	Fluorocarbon / (SK30506V-1)

Code	Port Size	Body Part No.
Omit	Cartridge Only	
6P	3/8" NTPF	(B10-4-*6P)
6T	SAE-6	(B10-4-*6T)
8T	SAE-8	(B10-4-*8T)
6B	3/8" BSPG	(B10-4-6B)†

** Add "A" for aluminum, omit for steel.
 † Steel bodies only*

Code	Sealed Pilot
Omit	If not required
S	Sealed Pilot

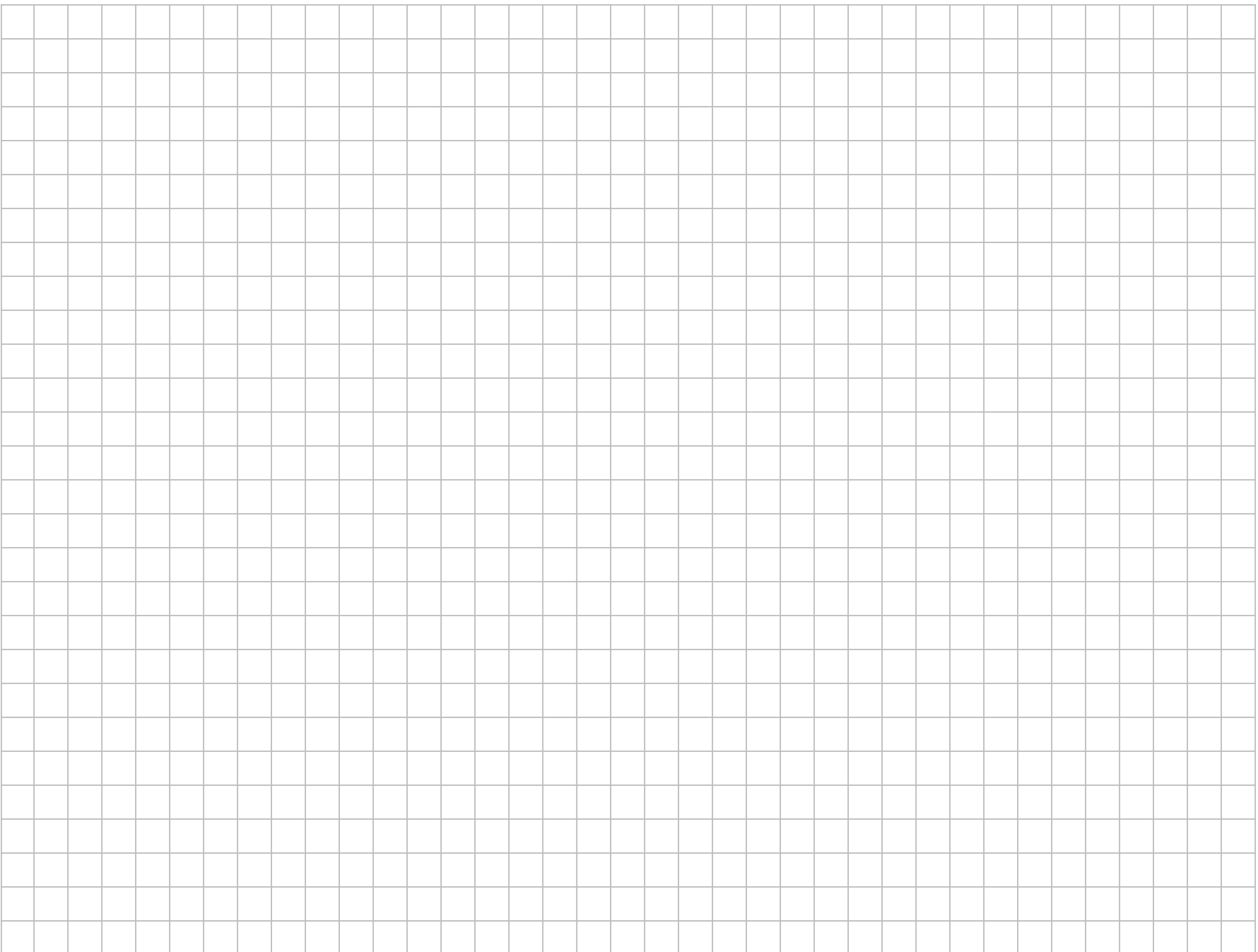

CV	Check Valves
SH	Shuttle Valves
LM	Load/Motor Controls
FC	Flow Controls
PC	Pressure Controls
LE	Logic Elements
DC	Directional Controls
MV	Manual Valves
SV	Solenoid Valves
PV	Proportional Valves
CE	Coils & Electronics
BC	Bodies & Cavities
TD	Technical Data



Technical Information

- CV** Check Valves
- SH** Shuttle Valves
- LM** Load/Motor Controls
- FC** Flow Controls
- PC** Pressure Controls
- LE** Logic Elements
- DC** Directional Controls
- MV** Manual Valves
- SV** Solenoid Valves
- PV** Proportional Valves
- CE** Coils & Electronics
- BC** Bodies & Cavities
- TD** Technical Data

General Description

3-Way Pilot Operated Spool Valve. The DH103A/B/C Series Valves are used in normally closed or normally open directional control three way circuits requiring remote pilot actuation. The DH103-D/E Series Valves are used to direct flow alternately from either side of a closed loop transmission for cooling or filtering. All external parts are zinc plated.

Operation

DH103A (Normally Open)

- Neutral (Deactivated)
Port (3) open to port (2), inlet port (4) is blocked.
 - Activated with pilot pressure at port (1):
Port (4) open to port (3), port (2) blocked.
- Note: There is an air breather vent plug in the end cap to allow for air pressure equalization in the spring chamber

DH103B (Normally Closed)

- Neutral (Deactivated)
Port (4) open to port (3), inlet port (2) is blocked.
- Activated with pilot pressure at port (1):
Port (3) open to port (2), port (4) blocked.

DH103C (Normally Open)

- Neutral (Deactivated)
Port (3) open to port (2), inlet port (4) is blocked.
- Activated with pilot pressure at port (1):
Port (4) open to port (3), port (2) blocked.

Specifications

Nominal Flow	38 LPM (10 GPM)
Maximum Inlet Pressure	240 Bar (3500 PSI)
Leakage at 150 SSU (32 cSt)	50 cc/min. at 240 Bar (3500 PSI)
Cartridge Material	All parts steel. All operating parts hardened steel.
Operating Temp. Range/Seals	-40°C to +93.3°C (Nitrile) (-40°F to +200°F) -31.7°C to +121.1°C (Fluorocarbon) (-25°F to +250°F)
Fluid Compatibility/Viscosity	Mineral-based or synthetic with lubricating properties at viscosities of 45 to 2000 SSU (6 to 420 cSt)
Filtration	ISO code 16/13, SAE Class 4 or better
Approx. Weight	0.23 kg (0.5 lbs.)
Cavity	C10-4 (See BC Section for more details)
Form Tool	Rougher NFT10-4R Finisher NFT10-4F



"A" SPOOL - DH103A

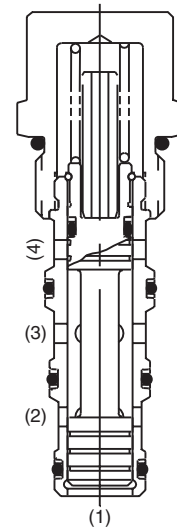
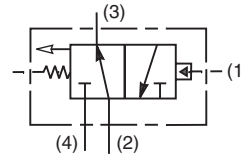

"A" SPOOL - DH103A

"B" SPOOL - DH103B

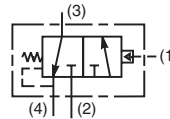
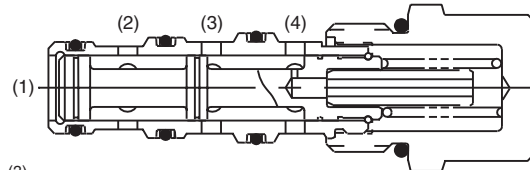

"C" SPOOL - DH103C

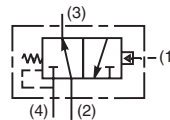
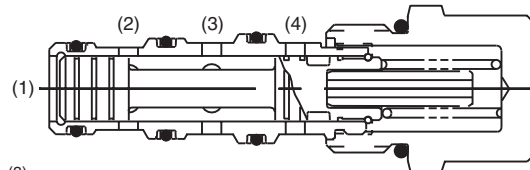

Performance Curve

Flow vs. Pressure Drop (Through cartridge only)

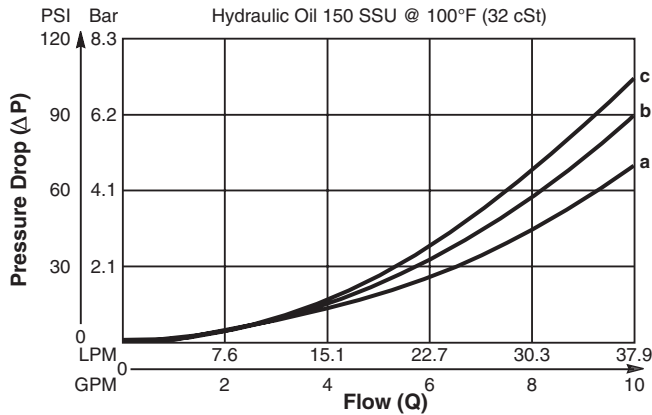

FLOW DIRECTION \ SPOOL NO.	A	B	C
SPOOL SHIFTED	3 → 4 c	2 → 3 d	3 → 4 c
SPOOL NEUTRAL	2 → 3 a	3 → 4 b	2 → 3 a

Dimensions Millimeters (Inches)

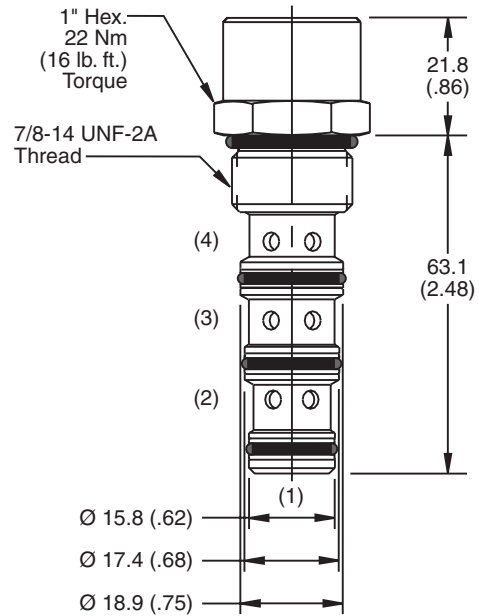

Ordering Information

DH103

10 Size Pilot Operated Spool Valve

Spool Type Pressure Differential Seals Body Material Port Size

Code / Spool Type	Diagram
A Normally open 2 position, vent to atmosphere.	
B Normally closed 2 position, internally drain.	
C Normally open, 2 position, internally drain.	

Code	Pressure Differential
Omit	5.5 Bar (80 PSI)
04	2.8 Bar (40 PSI)
16	11 Bar (160 PSI)

Code	Seals / Kit. No.
Omit	Nitrile / (SK10-4N)
V	Fluorocarbon / (SK10-4V)

Code	Body Material
Omit	Steel
A	Aluminum

Code	Port Size	Body Part No.
Omit	Cartridge Only	
4P	1/4" NPTF	(B10-4-*4P)
6P	3/8" NPTF	(B10-4-*6P)
8P	1/2" NPTF	(B10-4-*6P)
6T	SAE - 6	(B10-4-*6T)
8T	SAE - 8	(B10-4-*8T)
6B	3/8" BSPG	(B10-4-6B)†
8B	1/2" BSPG	(B10-4-*8B)

* Add "A" for aluminum, omit for steel.
 † Steel body only.

- CV** Check Valves
- SH** Shuttle Valves
- LM** Load/Motor Controls
- FC** Flow Controls
- PC** Pressure Controls
- LE** Logic Elements
- DC** Directional Controls
- MV** Manual Valves
- SV** Solenoid Valves
- PV** Proportional Valves
- CE** Coils & Electronics
- BC** Bodies & Cavities
- TD** Technical Data

- CV** Check Valves
- SH** Shuttle Valves
- LM** Load/Motor Controls
- FC** Flow Controls
- PC** Pressure Controls
- LE** Logic Elements
- DC** Directional Controls
- MV** Manual Valves
- SV** Solenoid Valves
- PV** Proportional Valves
- CE** Coils & Electronics
- BC** Bodies & Cavities
- TD** Technical Data

General Description

Pilot Operated Directional Valve, 3-Way External Pilot, Internal Vent.

Features

- High flow capacity
- Two switching pressures available
- Sealed pilot option available
- Hardened working parts for maximum durability
- All external parts zinc plated

Performance Curve

Pressure Drop vs. Flow (Through cartridge only)

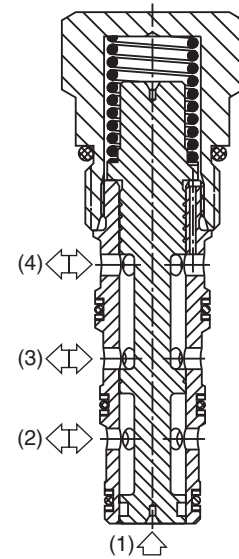
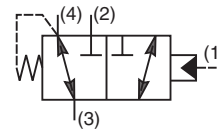
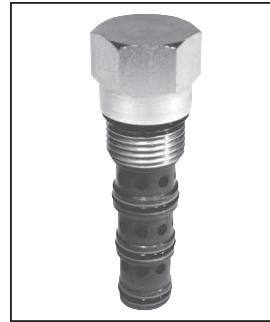
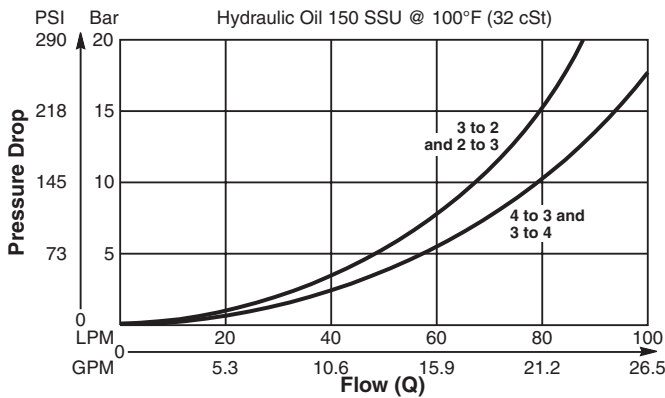

Dimensions

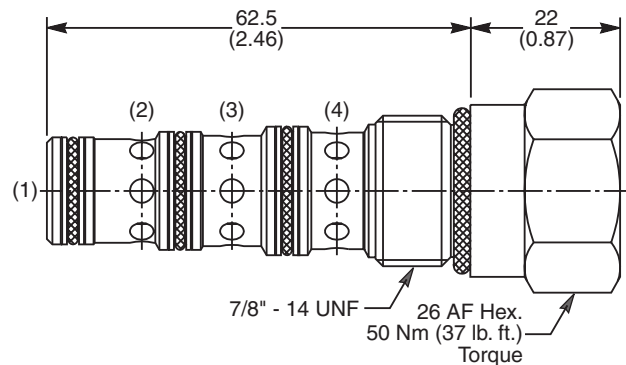

Specifications

Rated Flow	90 LPM (24 GPM)
Nominal Flow @ 7 Bar (100 PSI)	50 LPM (13 GPM)
Maximum Inlet Pressure	420 Bar (6000 PSI)
Pilot Switching Pressure	See ordering information
Cartridge Material	All parts steel. All operating parts hardened steel.
Operating Temp. Range/Seals	-40°C to +93.3°C (Nitrile, Buna-N) (-40°F to +200°F) -31.7°C to +121.1°C (Fluorocarbon) (-25°F to +250°F)
Fluid Compatibility/Viscosity	Mineral-based or synthetic with lubricating properties at viscosities of 45 to 2000 SSU (6 to 420 cSt)
Filtration	ISO code 16/13, SAE Class 4 or better
Approx. Weight	.17 kg (.37 lbs.)
Cavity	C10-4 (See BC Section for more details)

Ordering Information

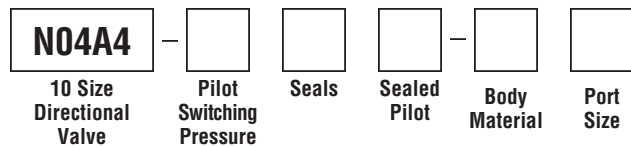

Code	Switching Pressure
5.0	5.0 Bar (73 PSI) Std.
10.0	10.0 Bar (145 PSI)

If no switching pressure is specified, valve will be supplied as N04A4-5.0N

Code	Body Material
Omit	Steel
A	Aluminum

Code	Seals / Kit No.
N	Nitrile, Buna-N / (SK30506N-1)
V	Fluorocarbon / (SK30506V-1)

Code	Port Size	Body Part No.
Omit	Cartridge Only	
6P	3/8" NTPF	(B10-4-*6P)
6T	SAE-6	(B10-4-*6T)
8T	SAE-8	(B10-4-*8T)
6B	3/8" BSPG	(B10-4-6B)†

* Add "A" for aluminum, omit for steel.
 † Steel bodies only

Code	Sealed Pilot
Omit	If not required
S	Sealed Pilot

General Description

Pilot Operated Directional Valve, 3-Way External Pilot, Internal Vent.

Features

- High flow capacity
- Two switching pressures available
- Sealed pilot option available
- Hardened working parts for maximum durability
- All external parts zinc plated

Performance Curve

Pressure Drop vs. Flow (Through cartridge only)

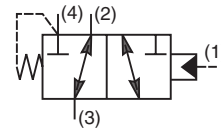
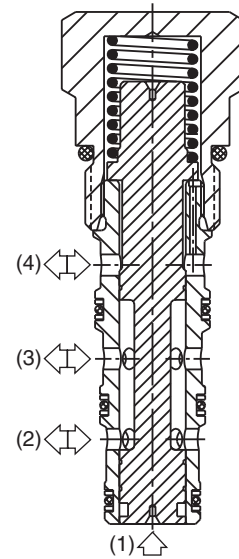
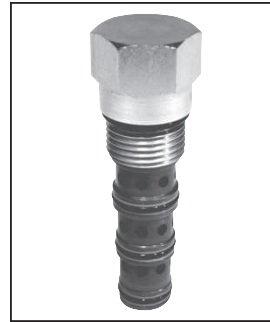
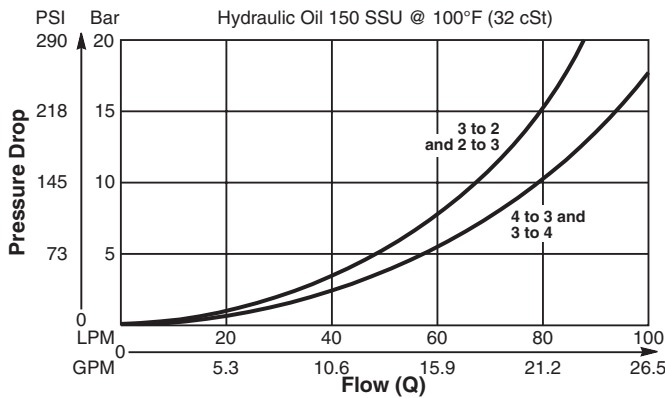

Dimensions Millimeters (Inches)

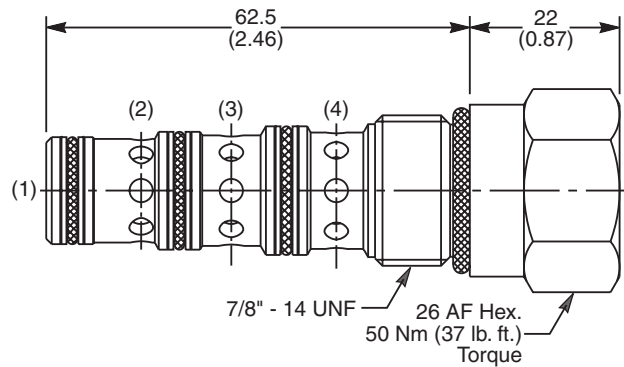

Specifications

Rated Flow	90 LPM (24 GPM)
Nominal Flow @ 7 Bar (100 PSI)	50 LPM (13 GPM)
Maximum Inlet Pressure	420 Bar (6000 PSI)
Pilot Switching Pressure	See ordering information
Cartridge Material	All parts steel. All operating parts hardened steel.
Operating Temp. Range/Seals	-40°C to +93.3°C (Nitrile, Buna-N) (-40°F to +200°F) -31.7°C to +121.1°C (Fluorocarbon) (-25°F to +250°F)
Fluid Compatibility/Viscosity	Mineral-based or synthetic with lubricating properties at viscosities of 45 to 2000 SSU (6 to 420 cSt)
Filtration	ISO code 16/13, SAE Class 4 or better
Approx. Weight	.17 kg (.37 lbs.)
Cavity	C10-4 (See BC Section for more details)

Ordering Information

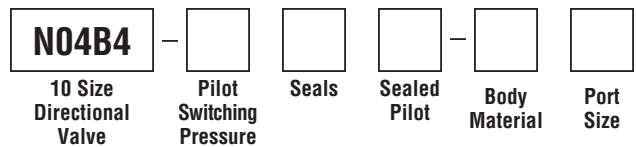

Code	Switching Pressure
5.0	5.0 Bar (73 PSI) Std.
10.0	10.0 Bar (145 PSI)

If no switching pressure is specified, valve will be supplied as N04B4-5.0N

Code	Seals / Kit No.
N	Nitrile, Buna-N / (SK30506N-1)
V	Fluorocarbon / (SK30506V-1)

Code	Sealed Pilot
Omit	If not required
S	Sealed Pilot

Code	Body Material
Omit	Steel
A	Aluminum

Code	Port Size	Body Part No.
Omit	Cartridge Only	
6P	3/8" NTPF	(B10-4-*6P)
6T	SAE-6	(B10-4-*6T)
8T	SAE-8	(B10-4-*8T)
6B	3/8" BSPG	(B10-4-6B)†

* Add "A" for aluminum, omit for steel.
 † Steel bodies only

Technical Information

- CV** Check Valves
- SH** Shuttle Valves
- LM** Load/Motor Controls
- FC** Flow Controls
- PC** Pressure Controls
- LE** Logic Elements
- DC** Directional Controls
- MV** Manual Valves
- SV** Solenoid Valves
- PV** Proportional Valves
- CE** Coils & Electronics
- BC** Bodies & Cavities
- TD** Technical Data

General Description

Pilot Operated Directional Valve, 3-Way External Pilot Vented to Atmosphere. Open Transition Feature.

Features

- High flow capacity
- Two switching pressures available
- Sealed pilot option available
- Hardened working parts for maximum durability
- All external parts zinc plated

Performance Curve

Pressure Drop vs. Flow (Through cartridge only)

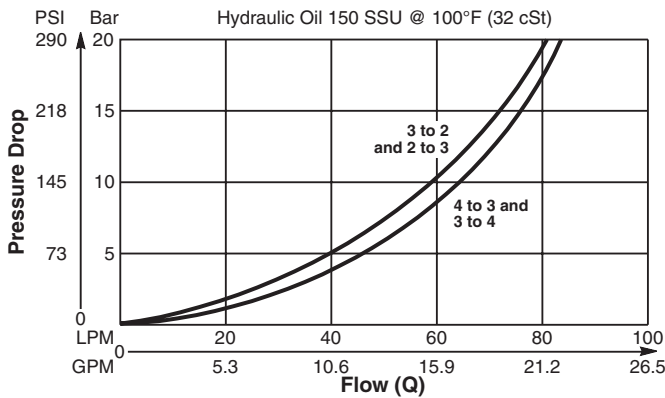

Specifications

Rated Flow	85 LPM (22.5 GPM)
Nominal Flow @ 7 Bar (100 PSI)	50 LPM (13 GPM)
Maximum Inlet Pressure	420 Bar (6000 PSI)
Pilot Switching Pressure	See ordering information
Cartridge Material	All parts steel. All operating parts hardened steel.
Operating Temp. Range/Seals	-40°C to +93.3°C (Nitrile, Buna-N) (-40°F to +200°F) -31.7°C to +121.1°C (Fluorocarbon) (-25°F to +250°F)
Fluid Compatibility/Viscosity	Mineral-based or synthetic with lubricating properties at viscosities of 45 to 2000 SSU (6 to 420 cSt)
Filtration	ISO code 16/13, SAE Class 4 or better
Approx. Weight	.22 kg (.48 lbs.)
Cavity	C10-4 (See BC Section for more details)

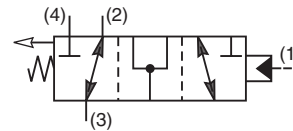
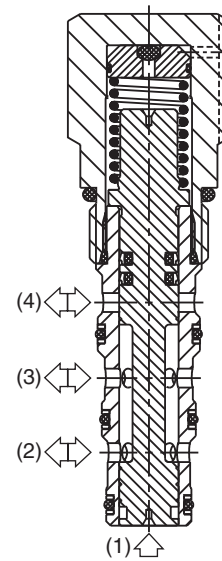
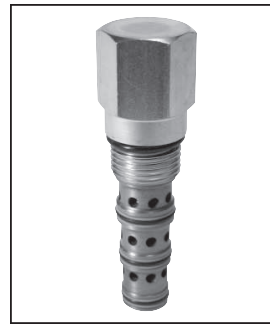

Dimensions Millimeters (Inches)

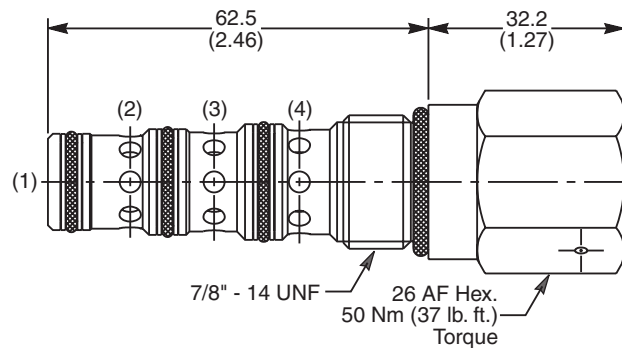

Ordering Information

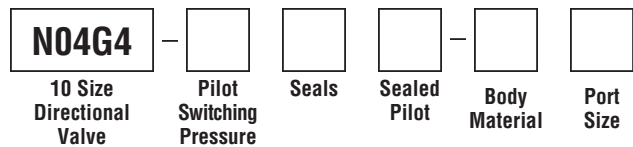

Code	Switching Pressure
10.0	10.0 Bar (145 PSI) Std.
15.0	15.0 Bar (218 PSI)

If no switching pressure is specified, valve will be supplied as N04G4-10.0N

Code	Body Material
Omit	Steel
A	Aluminum

Code	Seals / Kit No.
N	Nitrile, Buna-N / (SK30506N-1)
V	Fluorocarbon / (SK30506V-1)

Code	Port Size	Body Part No.
Omit	Cartridge Only	
6P	3/8" NTPF	(B10-4-*6P)
6T	SAE-6	(B10-4-*6T)
8T	SAE-8	(B10-4-*8T)
6B	3/8" BSPG	(B10-4-6B)†

* Add "A" for aluminum, omit for steel.
† Steel bodies only

Code	Sealed Pilot
Omit	If not required
S	Sealed Pilot

General Description

Pilot Operated Directional Valve, 3-Way External Pilot Vented to Atmosphere. Open Transition Feature.

Features

- High flow capacity
- Two switching pressures available
- Sealed pilot option available
- Hardened working parts for maximum durability
- All external parts zinc plated

Performance Curve

Pressure Drop vs. Flow (Through cartridge only)

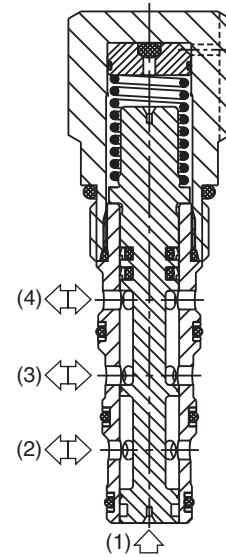
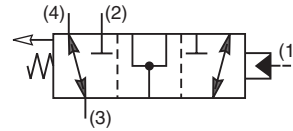
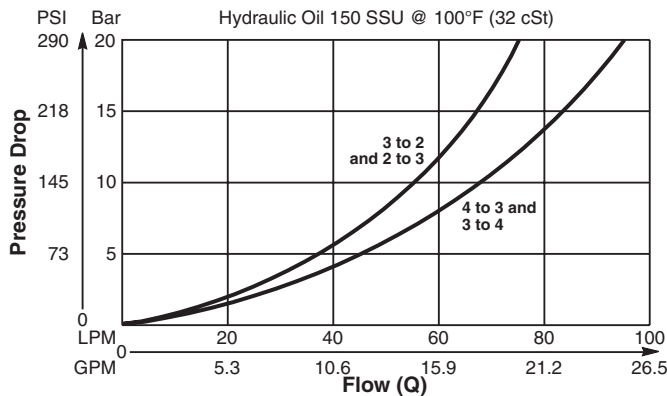

Dimensions Millimeters (Inches)

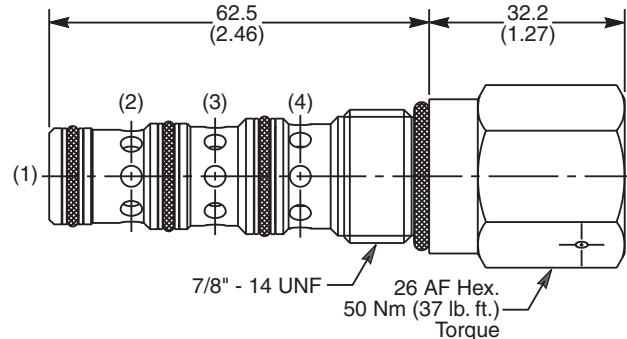

Specifications

Rated Flow	85 LPM (22.5 GPM)
Nominal Flow @ 7 Bar (100 PSI)	50 LPM (13 GPM)
Maximum Inlet Pressure	420 Bar (6000 PSI)
Pilot Switching Pressure	See ordering information
Cartridge Material	All parts steel. All operating parts hardened steel.
Operating Temp. Range/Seals	-40°C to +93.3°C (Nitrile, Buna-N) (-40°F to +200°F) -31.7°C to +121.1°C (Fluorocarbon) (-25°F to +250°F)
Fluid Compatibility/Viscosity	Mineral-based or synthetic with lubricating properties at viscosities of 45 to 2000 SSU (6 to 420 cSt)
Filtration	ISO code 16/13, SAE Class 4 or better
Approx. Weight	.22 kg (.48 lbs.)
Cavity	C10-4 (See BC Section for more details)

Ordering Information

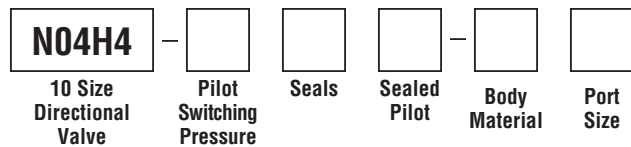

Code	Switching Pressure
10.0	10.0 Bar (145 PSI) Std.
15.0	15.0 Bar (218 PSI)

If no switching pressure is specified, valve will be supplied as N04H4-10.0N

Code	Seals / Kit No.
N	Nitrile, Buna-N / (SK30506N-1)
V	Fluorocarbon / (SK30506V-1)

Code	Sealed Pilot
Omit	If not required
S	Sealed Pilot

Code	Body Material
Omit	Steel
A	Aluminum

Code	Port Size	Body Part No.
Omit	Cartridge Only	
6P	3/8" NTPF	(B10-4-*6P)
6T	SAE-6	(B10-4-*6T)
8T	SAE-8	(B10-4-*8T)
6B	3/8" BSPG	(B10-4-6B)†

* Add "A" for aluminum, omit for steel.
 † Steel bodies only

- CV** Check Valves
- SH** Shuttle Valves
- LM** Load/Motor Controls
- FC** Flow Controls
- PC** Pressure Controls
- LE** Logic Elements
- DC** Directional Controls
- MV** Manual Valves
- SV** Solenoid Valves
- PV** Proportional Valves
- CE** Coils & Electronics
- BC** Bodies & Cavities
- TD** Technical Data

Technical Information

- CV Check Valves
- SH Shuttle Valves
- LM Load/Motor Controls
- FC Flow Controls
- PC Pressure Controls
- LE Logic Elements
- DC Directional Controls
- MV Manual Valves
- SV Solenoid Valves
- PV Proportional Valves
- CE Coils & Electronics
- BC Bodies & Cavities
- TD Technical Data

General Description

Pilot Operated Directional Valve, 3-Way, 2 Position, External Drain, Open Transition.

Features

- High flow capacity
- Used as high flow switching or metering element
- Range of spring settings available
- All external parts zinc plated

Performance Curve

Pressure Drop vs. Flow (Through cartridge only)

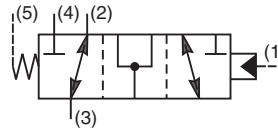
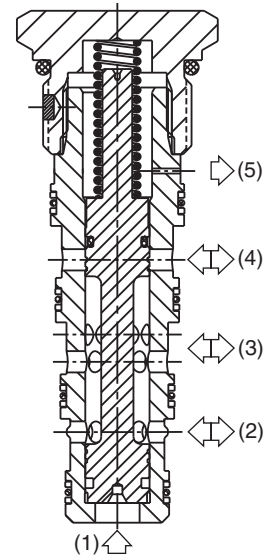
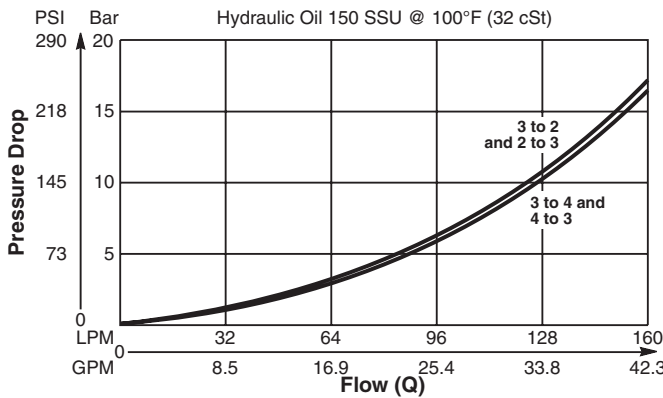

Dimensions Millimeters (Inches)

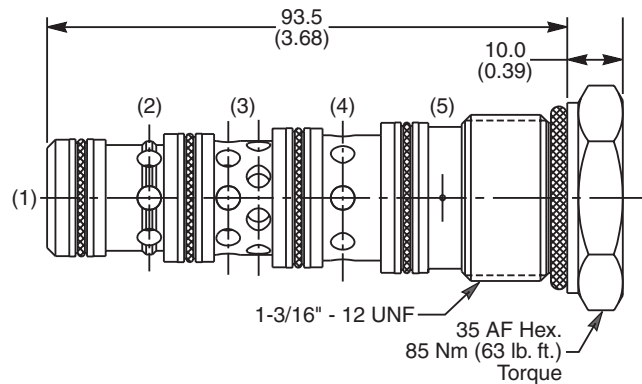

Specifications

Rated Flow	160 LPM (42.3 GPM)
Nominal Flow @ 7 Bar (100 PSI)	90 LPM (24 GPM)
Maximum Inlet Pressure	420 Bar (6000 PSI)
Pilot Switching Pressure	See ordering information
Cartridge Material	Steel operating parts, hardened steel spool.
Operating Temp. Range/Seals	-40°C to +93.3°C (Nitrile, Buna-N) (-40°F to +200°F) -31.7°C to +121.1°C (Fluorocarbon) (-25°F to +250°F)
Fluid Compatibility/Viscosity	Mineral-based or synthetic with lubricating properties at viscosities of 45 to 2000 SSU (6 to 420 cSt)
Filtration	ISO code 16/13, SAE Class 4 or better
Approx. Weight	.33 kg (.76 lbs.)
Cavity	5A (See BC Section for more details)

Ordering Information

N5A125 — Directional Valve (All Ports Open) Pilot Switching Pressure Seals

Code	Switching Pressure
0.0	0.0 Bar (0 PSI)
5.0	5.0 Bar (73 PSI)
6.9	6.9 Bar (100 PSI) Std.
10.0	10.0 Bar (145 PSI)
15.0	15.0 Bar (217 PSI)

If no switching pressure is specified, valve will be supplied as N5A125-6.9N

Code	Seals / Kit No.
N	Nitrile, Buna-N / (SK30103N-1)
V	Fluorocarbon / (SK30103V-1)

Order Bodies Separately

LB10 Line Body Porting Body Material

Code	Porting
314	3/4" BSP (main) 1/4" BSP (aux)
321	3/4" SAE (main) 1/4" SAE (aux)

Code	Body Material
A	Aluminum
S	Steel



General Description

Pilot Operated Directional Valve, 3-Way, 2 Position, External Drain, Open Transition.

Features

- High flow capacity
- Used as high flow switching or metering element
- Range of spring settings available
- All external parts zinc plated

Performance Curve

Pressure Drop vs. Flow (Through cartridge only)

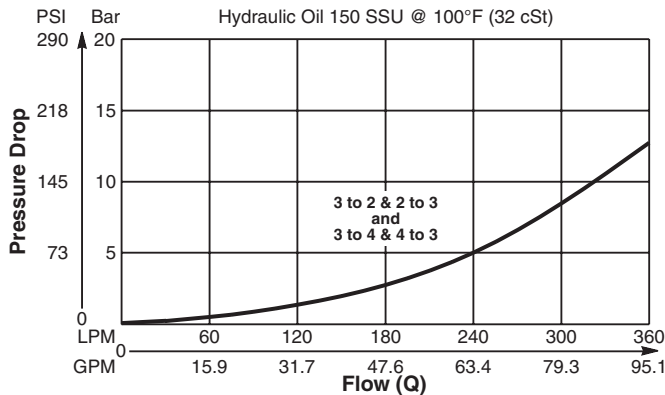

Specifications

Rated Flow	400 LPM (105 GPM)
Nominal Flow @ 7 Bar (100 PSI)	270 LPM (71 GPM)
Maximum Inlet Pressure	420 Bar (6000 PSI)
Pilot Switching Pressure	See ordering information
Cartridge Material	Steel operating parts, hardened steel spool.
Operating Temp. Range/Seals	-40°C to +93.3°C (Nitrile, Buna-N) (-40°F to +200°F) -31.7°C to +121.1°C (Fluorocarbon) (-25°F to +250°F)
Fluid Compatibility/Viscosity	Mineral-based or synthetic with lubricating properties at viscosities of 45 to 2000 SSU (6 to 420 cSt)
Filtration	ISO code 16/13, SAE Class 4 or better
Approx. Weight	1.00 kg (2.2 lbs.)
Cavity	100-1 (See BC Section for more details)

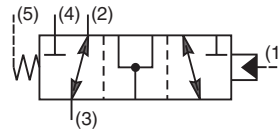
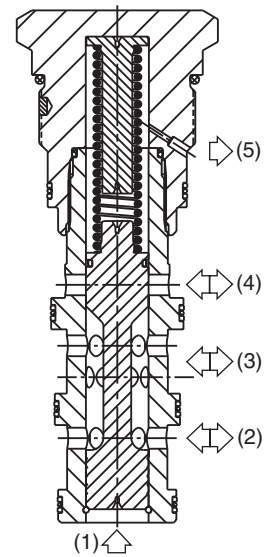

Dimensions Millimeters (Inches)

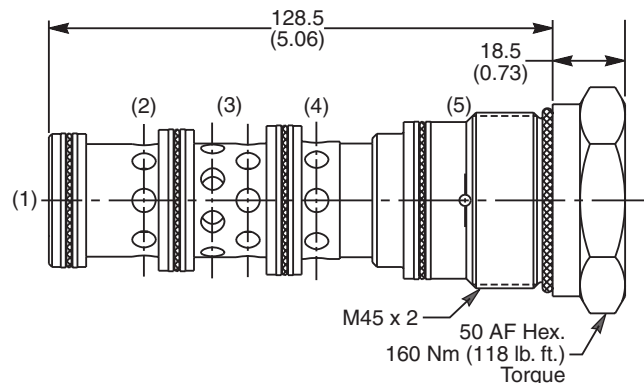

Ordering Information

N5A300 — Directional Valve (All Ports Open) Pilot Switching Pressure Seals

Code	Switching Pressure
3.0	3.0 Bar (44 PSI)
6.9	6.9 Bar (100 PSI) Std.
10.0	10.0 Bar (145 PSI)

If no switching pressure is specified, valve will be supplied as N5A300-6.9N

Code	Seals / Kit No.
N	Nitrile, Buna-N / (SK30065N-1)
V	Fluorocarbon / (SK30065V-1)

Order Bodies Separately

LB10 — Line Body Porting Body Material

Code	Porting
316	1-1/4" BSP (main) 3/8" BSP (aux)
317	1-1/4" SAE (main) 3/8" SAE (aux)

Code	Body Material
A	Aluminum
S	Steel

- CV** Check Valves
- SH** Shuttle Valves
- LM** Load/Motor Controls
- FC** Flow Controls
- PC** Pressure Controls
- LE** Logic Elements
- DC** Directional Controls
- MV** Manual Valves
- SV** Solenoid Valves
- PV** Proportional Valves
- CE** Coils & Electronics
- BC** Bodies & Cavities
- TD** Technical Data

Technical Information

- CV** Check Valves
- SH** Shuttle Valves
- LM** Load/Motor Controls
- FC** Flow Controls
- PC** Pressure Controls
- LE** Logic Elements
- DC** Directional Controls
- MV** Manual Valves
- SV** Solenoid Valves
- PV** Proportional Valves
- CE** Coils & Electronics
- BC** Bodies & Cavities
- TD** Technical Data

General Description

Pilot Operated Directional Valve, 3-Way, 2 Position, External Drain, Closed Transition.

Features

- High flow capacity
- Used as high flow switching or metering element
- Range of spring settings available
- All external parts zinc plated

Performance Curve

Pressure Drop vs. Flow (Through cartridge only)

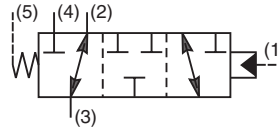
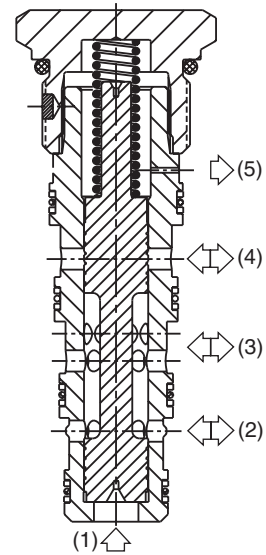
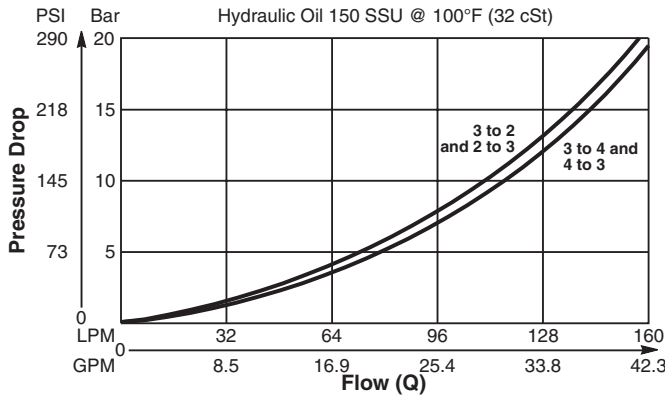

Dimensions Millimeters (Inches)

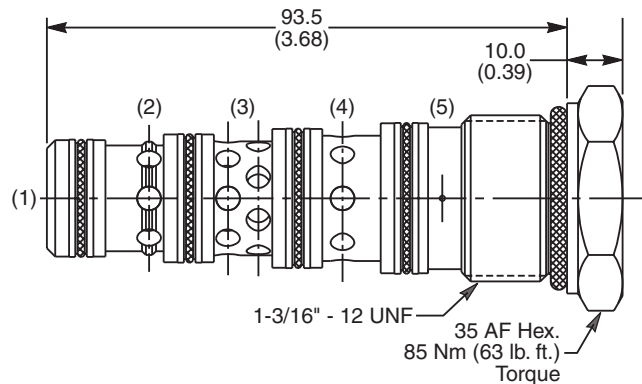

Specifications

Rated Flow	160 LPM (42.3 GPM)
Nominal Flow @ 7 Bar (100 PSI)	90 LPM (24 GPM)
Maximum Inlet Pressure	420 Bar (6000 PSI)
Pilot Switching Pressure	See ordering information
Cartridge Material	Steel operating parts, hardened steel spool.
Operating Temp. Range/Seals	-40°C to +93.3°C (Nitrile, Buna-N) (-40°F to +200°F) -31.7°C to +121.1°C (Fluorocarbon) (-25°F to +250°F)
Fluid Compatibility/Viscosity	Mineral-based or synthetic with lubricating properties at viscosities of 45 to 2000 SSU (6 to 420 cSt)
Filtration	ISO code 16/13, SAE Class 4 or better
Approx. Weight	.33 kg (.76 lbs.)
Cavity	5A (See BC Section for more details)

Ordering Information

N5B125 — Directional Valve (All Ports Closed) Pilot Switching Pressure Seals

Code	Switching Pressure
0.0	0.0 Bar (0 PSI)
5.0	5.0 Bar (73 PSI)
6.9	6.9 Bar (100 PSI) Std.
10.0	10.0 Bar (145 PSI)
15.0	15.0 Bar (217 PSI)

If no switching pressure is specified, valve will be supplied as N5B125-6.9N

Code	Seals / Kit No.
N	Nitrile, Buna-N / (SK30103N-1)
V	Fluorocarbon / (SK30103V-1)

Order Bodies Separately

LB10 Line Body Porting Body Material

Code	Porting
314	3/4" BSP (main) 1/4" BSP (aux)
321	3/4" SAE (main) 1/4" SAE (aux)

Code	Body Material
A	Aluminum
S	Steel



General Description

Pilot Operated Directional Valve, 3-Way, 2 Position, External Drain, Closed Transition.

Features

- High flow capacity
- Used as high flow switching or metering element
- Range of spring settings available
- All external parts zinc plated

Performance Curve

Pressure Drop vs. Flow (Through cartridge only)

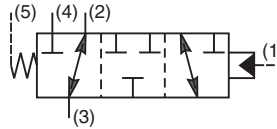
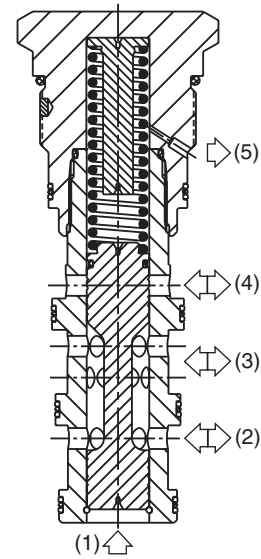
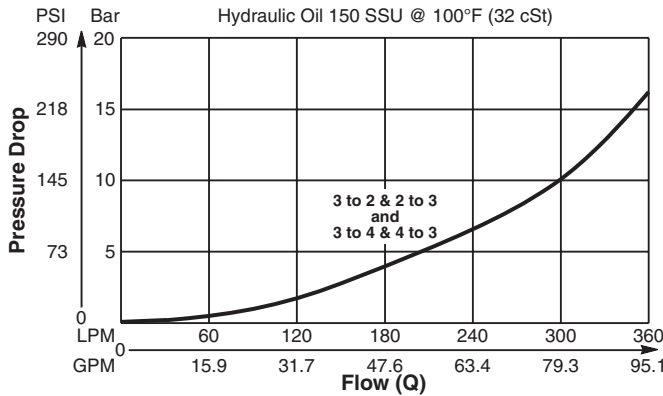

Dimensions Millimeters (Inches)

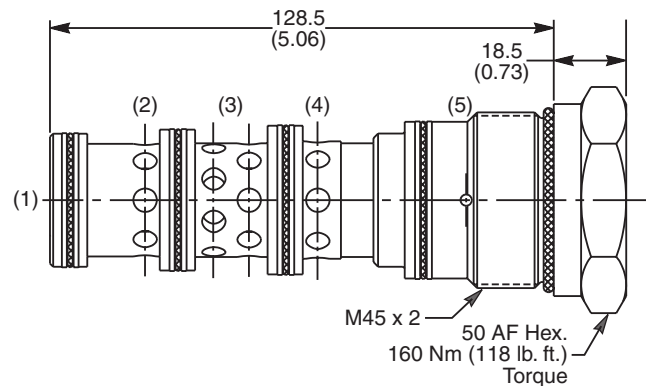

Specifications

Rated Flow	400 LPM (105 GPM)
Nominal Flow @ 7 Bar (100 PSI)	270 LPM (71 GPM)
Maximum Inlet Pressure	420 Bar (6000 PSI)
Pilot Switching Pressure	See ordering information
Cartridge Material	Steel operating parts, hardened steel spool.
Operating Temp. Range/Seals	-40°C to +93.3°C (Nitrile, Buna-N) (-40°F to +200°F) -31.7°C to +121.1°C (Fluorocarbon) (-25°F to +250°F)
Fluid Compatibility/Viscosity	Mineral-based or synthetic with lubricating properties at viscosities of 45 to 2000 SSU (6 to 420 cSt)
Filtration	ISO code 16/13, SAE Class 4 or better
Approx. Weight	1.00 kg (2.2 lbs.)
Cavity	100-1 (See BC Section for more details)

Ordering Information

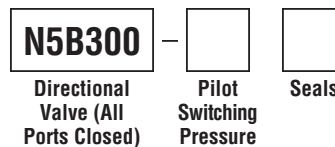

Code	Switching Pressure
3.0	3.0 Bar (44 PSI)
6.9	6.9 Bar (100 PSI) Std.
10.0	10.0 Bar (145 PSI)

If no switching pressure is specified, valve will be supplied as N5B300-6.9N

Code	Seals / Kit No.
N	Nitrile, Buna-N / (SK30065N-1)
V	Fluorocarbon / (SK30065V-1)

Order Bodies Separately



Code	Porting
316	1-1/4" BSP (main) 3/8" BSP (aux)
317	1-1/4" SAE (main) 3/8" SAE (aux)

Code	Body Material
A	Aluminum
S	Steel

- CV** Check Valves
- SH** Shuttle Valves
- LM** Load/Motor Controls
- FC** Flow Controls
- PC** Pressure Controls
- LE** Logic Elements
- DC** Directional Controls
- MV** Manual Valves
- SV** Solenoid Valves
- PV** Proportional Valves
- CE** Coils & Electronics
- BC** Bodies & Cavities
- TD** Technical Data

- CV** Check Valves
- SH** Shuttle Valves
- LM** Load/Motor Controls
- FC** Flow Controls
- PC** Pressure Controls
- LE** Logic Elements
- DC** Directional Controls
- MV** Manual Valves
- SV** Solenoid Valves
- PV** Proportional Valves
- CE** Coils & Electronics
- BC** Bodies & Cavities
- TD** Technical Data

General Description

Diverter Valve, 3-Way, 2 Position, External Drain, Normally Open.

Features

- High flow capacity
- Used as high flow switching or metering element
- Range of spring settings available
- Sealed pilot option available
- All external parts zinc plated

Performance Curve

Pressure Drop vs. Flow (Through cartridge only)

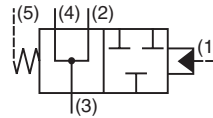
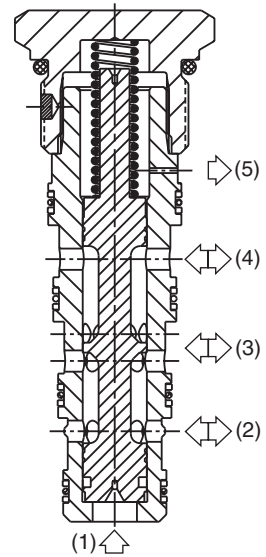
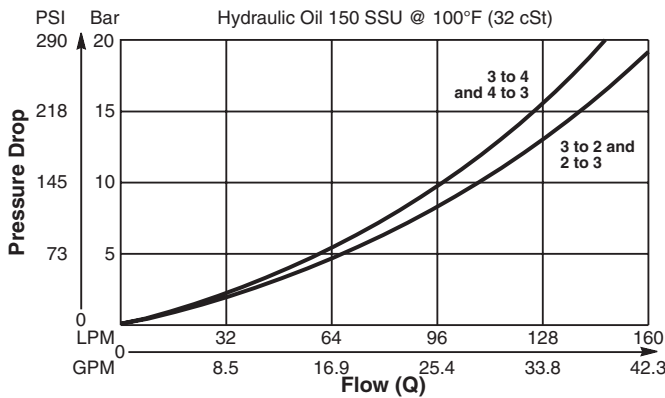

Dimensions

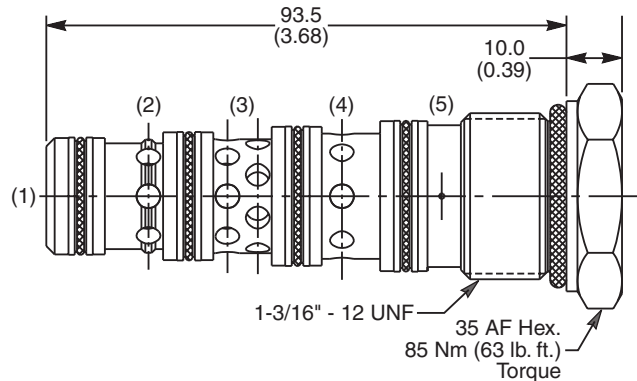

Specifications

Rated Flow	160 LPM (42.3 GPM)
Nominal Flow @ 7 Bar (100 PSI)	80 LPM (21 GPM)
Maximum Inlet Pressure	420 Bar (6000 PSI)
Pilot Switching Pressure	See ordering information
Cartridge Material	Steel operating parts, hardened steel spool.
Operating Temp. Range/Seals	-40°C to +93.3°C (Nitrile, Buna-N) (-40°F to +200°F) -31.7°C to +121.1°C (Fluorocarbon) (-25°F to +250°F)
Fluid Compatibility/Viscosity	Mineral-based or synthetic with lubricating properties at viscosities of 45 to 2000 SSU (6 to 420 cSt)
Filtration	ISO code 16/13, SAE Class 4 or better
Approx. Weight	.33 kg (.76 lbs.)
Cavity	5A (See BC Section for more details)

Ordering Information

N5C125 —
 Diverter Valve Pilot Seals
 (All Ports Open) Switching Pressure

Code	Switching Pressure
0.0	0.0 Bar (0 PSI)
5.0	5.0 Bar (73 PSI)
6.9	6.9 Bar (100 PSI) Std.
10.0	10.0 Bar (145 PSI)
15.0	15.0 Bar (217 PSI)

If no switching pressure is specified, valve will be supplied as N5C125-6.9N

Code	Seals / Kit No.
N	Nitrile, Buna-N / (SK30103N-1)
V	Fluorocarbon / (SK30103V-1)

Order Bodies Separately

LB10
 Line Body Porting Body Material

Code	Porting
314	3/4" BSP (main) 1/4" BSP (aux)
321	3/4" SAE (main) 1/4" SAE (aux)

Code	Body Material
A	Aluminum
S	Steel

General Description

Diverter Valve, 3-Way, 2 Position, External Drain, Normally Open.

Features

- High flow capacity
- Used as high flow switching or metering element
- Range of spring settings available
- All external parts zinc plated

Performance Curve

Pressure Drop vs. Flow (Through cartridge only)

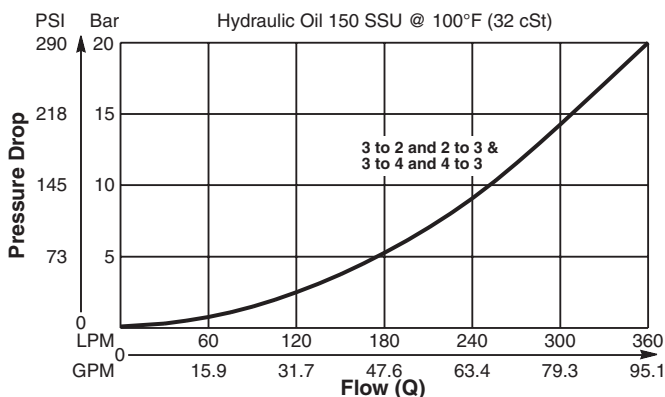

Specifications

Rated Flow	400 LPM (105 GPM)
Nominal Flow @ 7 Bar (100 PSI)	3 to 2 - 130 LPM (34 GPM) 3 to 4 - 240 LPM (63 GPM)
Maximum Inlet Pressure	420 Bar (6000 PSI)
Pilot Switching Pressure	See ordering information
Cartridge Material	Steel operating parts, hardened steel spool.
Operating Temp. Range/Seals	-40°C to +93.3°C (Nitrile, Buna-N) (-40°F to +200°F) -31.7°C to +121.1°C (Fluorocarbon) (-25°F to +250°F)
Fluid Compatibility/Viscosity	Mineral-based or synthetic with lubricating properties at viscosities of 45 to 2000 SSU (6 to 420 cSt)
Filtration	ISO code 16/13, SAE Class 4 or better
Approx. Weight	1.00 kg (2.2 lbs.)
Cavity	100-1 (See BC Section for more details)

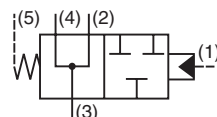
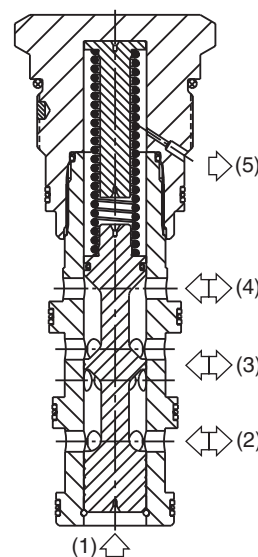

Dimensions Millimeters (Inches)

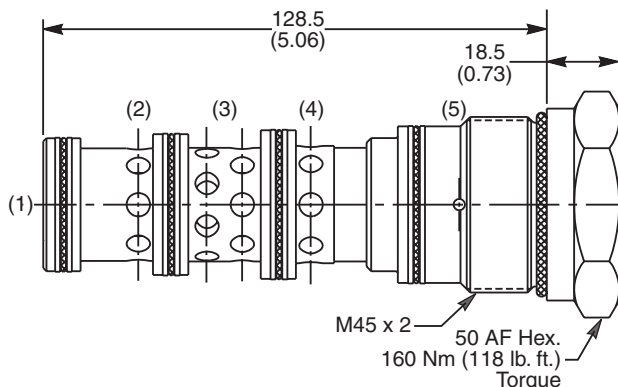

Ordering Information

N5C300 —
 Diverter Valve (All Ports Open) Pilot Switching Pressure Seals

Code	Switching Pressure
3.0	3.0 Bar (44 PSI)
6.9	6.9 Bar (100 PSI) Std.
10.0	10.0 Bar (145 PSI)

If no switching pressure is specified, valve will be supplied as N5C300-6.9N

Code	Seals / Kit No.
N	Nitrile, Buna-N / (SK30065N-1)
V	Fluorocarbon / (SK30065V-1)

Order Bodies Separately

LB10
 Line Body Porting Body Material

Code	Porting
316	1-1/4" BSP (main) 3/8" BSP (aux)
317	1-1/4" SAE (main) 3/8" SAE (aux)

Code	Body Material
A	Aluminum
S	Steel

CV Check Valves

SH Shuttle Valves

LM Load/Motor Controls

FC Flow Controls

PC Pressure Controls

LE Logic Elements

DC Directional Controls

MV Manual Valves

SV Solenoid Valves

PV Proportional Valves

CE Coils & Electronics

BC Bodies & Cavities

TD Technical Data

- CV** Check Valves
- SH** Shuttle Valves
- LM** Load/Motor Controls
- FC** Flow Controls
- PC** Pressure Controls
- LE** Logic Elements
- DC** Directional Controls
- MV** Manual Valves
- SV** Solenoid Valves
- PV** Proportional Valves
- CE** Coils & Electronics
- BC** Bodies & Cavities
- TD** Technical Data

General Description

Diverter Valve, 3-Way, 2 Position, External Drain, Normally Closed.

Features

- High flow capacity
- Used as high flow switching or metering element
- Range of spring settings available
- Sealed pilot option available
- All external parts zinc plated

Performance Curve

Pressure Drop vs. Flow (Through cartridge only)

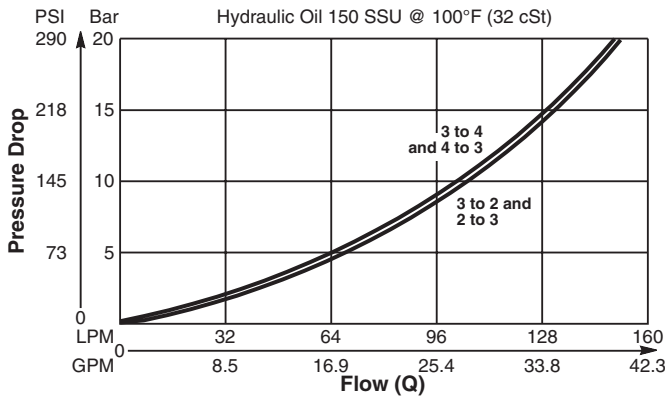

Specifications

Rated Flow	160 LPM (42.3 GPM)
Nominal Flow @ 7 Bar (100 PSI)	80 LPM (21 GPM)
Maximum Inlet Pressure	420 Bar (6000 PSI)
Pilot Switching Pressure	See ordering information
Cartridge Material	Steel operating parts, hardened steel spool.
Operating Temp. Range/Seals	-40°C to +93.3°C (Nitrile, Buna-N) (-40°F to +200°F) -31.7°C to +121.1°C (Fluorocarbon) (-25°F to +250°F)
Fluid Compatibility/Viscosity	Mineral-based or synthetic with lubricating properties at viscosities of 45 to 2000 SSU (6 to 420 cSt)
Filtration	ISO code 16/13, SAE Class 4 or better
Approx. Weight	.33 kg (.76 lbs.)
Cavity	5A (See BC Section for more details)

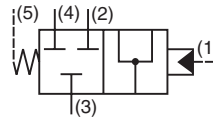
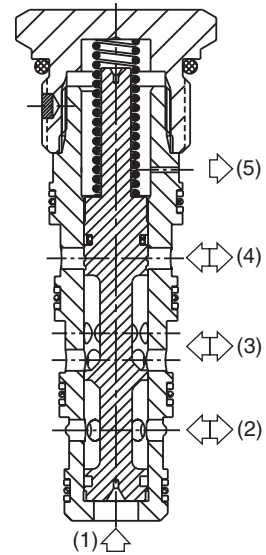

Dimensions

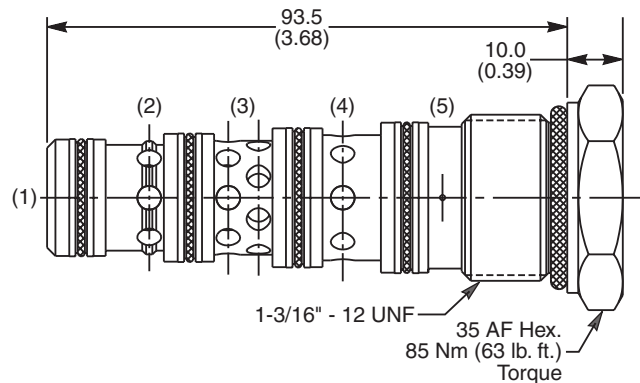

Ordering Information

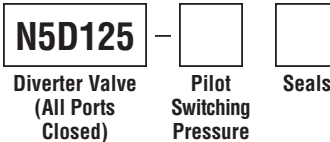

Code	Switching Pressure
0.0	0.0 Bar (0 PSI)
5.0	5.0 Bar (73 PSI)
6.9	6.9 Bar (100 PSI) Std.
10.0	10.0 Bar (145 PSI)
15.0	15.0 Bar (217 PSI)

If no switching pressure is specified, valve will be supplied as N5D125-6.9N

Code	Seals / Kit No.
N	Nitrile, Buna-N / (SK30103N-1)
V	Fluorocarbon / (SK30103V-1)

Order Bodies Separately



Code	Porting
314	3/4" BSP (main) 1/4" BSP (aux)
321	3/4" SAE (main) 1/4" SAE (aux)

Code	Body Material
A	Aluminum
S	Steel

General Description

Diverter Valve, 3-Way, 2 Position, External Drain, Normally Closed.

Features

- High flow capacity
- Used as high flow switching or metering element
- Range of spring settings available
- All external parts zinc plated

Performance Curve

Pressure Drop vs. Flow (Through cartridge only)

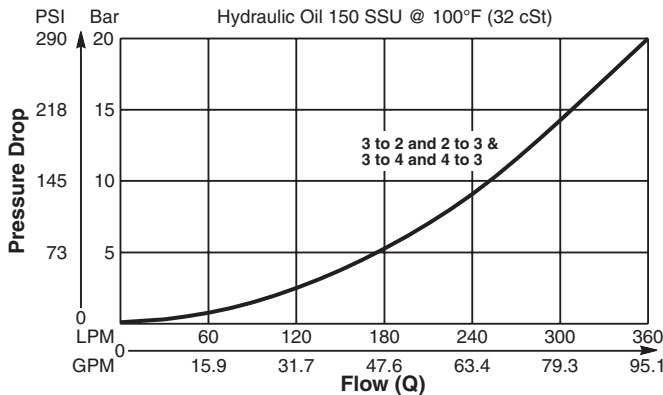

Specifications

Rated Flow	400 LPM (105 GPM)
Nominal Flow @ 7 Bar (100 PSI)	3 to 2 - 200 LPM (53 GPM) 3 to 4 - 200 LPM (53 GPM)
Maximum Inlet Pressure	420 Bar (6000 PSI)
Pilot Switching Pressure	See ordering information
Cartridge Material	Steel operating parts, hardened steel spool.
Operating Temp. Range/Seals	-40°C to +93.3°C (Nitrile, Buna-N) (-40°F to +200°F) -31.7°C to +121.1°C (Fluorocarbon) (-25°F to +250°F)
Fluid Compatibility/Viscosity	Mineral-based or synthetic with lubricating properties at viscosities of 45 to 2000 SSU (6 to 420 cSt)
Filtration	ISO code 16/13, SAE Class 4 or better
Approx. Weight	1.00 kg (2.2 lbs.)
Cavity	100-1 (See BC Section for more details)

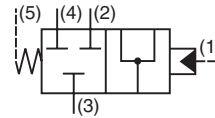
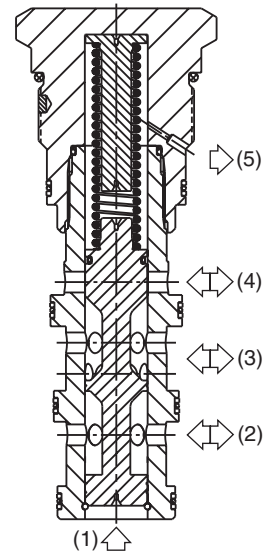

Dimensions Millimeters (Inches)

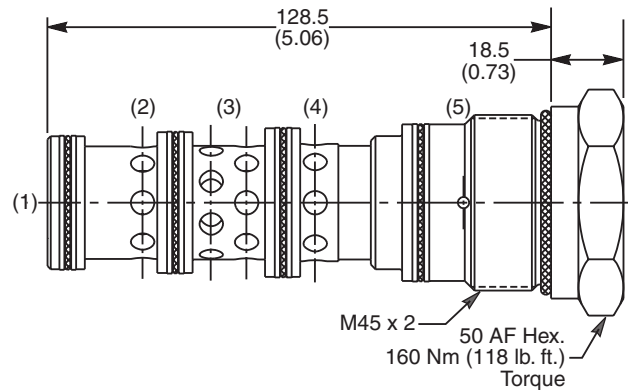

Ordering Information

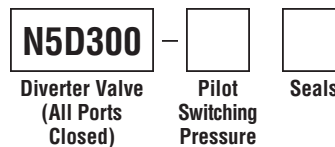

Code	Switching Pressure
3.0	3.0 Bar (44 PSI)
6.9	6.9 Bar (100 PSI) Std.
10.0	10.0 Bar (145 PSI)

If no switching pressure is specified, valve will be supplied as N5D300-6.9N

Code	Seals / Kit No.
N	Nitrile, Buna-N / (SK30065N-1)
V	Fluorocarbon / (SK30065V-1)

Order Bodies Separately



Code	Porting
316	1-1/4" BSP (main) 3/8" BSP (aux)
317	1-1/4" SAE (main) 3/8" SAE (aux)

Code	Body Material
A	Aluminum
S	Steel

- CV** Check Valves
- SH** Shuttle Valves
- LM** Load/Motor Controls
- FC** Flow Controls
- PC** Pressure Controls
- LE** Logic Elements
- DC** Directional Controls
- MV** Manual Valves
- SV** Solenoid Valves
- PV** Proportional Valves
- CE** Coils & Electronics
- BC** Bodies & Cavities
- TD** Technical Data

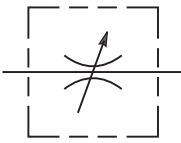
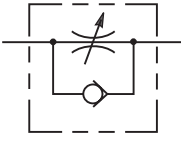
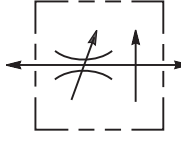
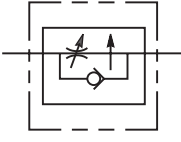
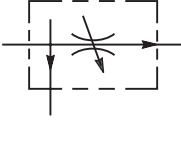
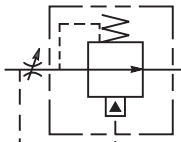
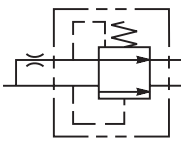
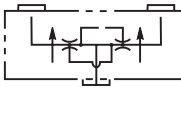
	SERIES	CAVITY	DESCRIPTION	FLOW LPM/GPM	PRESSURE BAR/PSI	PAGE NO.	
	NEEDLE VALVES						
		J02A2	C08-2	Needle Valve, Cartridge Type	45/12	420/6000	FC5-FC6
	☆	NVH081	C08-2	Needle Valve, Cartridge Type	38/10	380/5500	FC7-FC8
	☆	NVH101	C10-2	Needle Valve, Cartridge Type	60/16	380/5500	FC9-FC10
		J06A2	C16-2	Needle Valve, Cartridge Type	225/60	420/6000	FC11-FC12
	J02B2	C08-2	Needle Valve with Reverse Check, 2 to 1 Free Flow	30/8	420/6000	FC13-FC14	
		FV101	C10-2	Needle Valve with Reverse Check, 1 to 2 Free Flow	45/12	210/3000	FC15-FC16
		FV102	C10-2	Needle Valve with Reverse Check, 1 to 2 Free Flow	23/6	210/3000	FC15-FC16
	PRESSURE COMPENSATED FLOW CONTROLS						
		J02E2	C08-2	Restrictive Flow Control, Adjustable	20/5.3	420/6000	FC17-FC18
		FR101	C10-2	Restrictive Flow Control, Tuneable	26/7	245/3500	FC19-FC20
		J04E2	C10-2	Restrictive Flow Control, Adjustable	40/10	420/6000	FC21-FC22
	J04C2	C10-2	Restrictive Flow Control, Adjustable	40/10	420/6000	FC23-FC24	
		FA101	C10-2	Restrictive Flow Control, Reverse Check, Adjustable	21/5.5	210/3000	FC25-FC26
		FC101	C10-2	Restrictive Flow Control, Reverse Check, Tuneable	56/15	210/3000	FC27-FC28
	PRESSURE COMPENSATED PRIORITY FLOW CONTROLS						
		J02D3	C08-3	Priority Type, with Bypass	15/4	420/6000	FC29-FC30
		FP101	C10-3	Priority Type, with Bypass	56/15	245/3500	FC31-FC32
		J04D3	C10-3	Priority Type, with Bypass	45/12	420/6000	FC33-FC34
		J1A125	3A	Priority Type, with Bypass	90/24	350/5000	FC35-FC36
	PRESSURE COMPENSATORS						
		FCR101	C10-3	Restrictive Type, Press. Compensators	38/10	245/3500	FC37
	FCR161	C16-3	Restrictive Type, Press. Compensators	150/40	245/3500	FC38	
<i>Note: Also see R04C3 on page DC1.</i>							
	PRIORITY PRESSURE COMPENSATORS						
		FCP101	C10-4	Priority Type, with Bypass	56/15	245/3500	FC39
	FCPH121	C12-4	Priority Type, with Bypass	95/25	380/5500	FC41-FC42	
	FLOW DIVIDERS/COMBINERS						
		FDC101	C10-4	Flow Divider/Combiner	45/12	245/3500	FC43-FC44
		L04A3	C10-4	Flow Divider/Combiner	60/16	420/6000	FC45-FC46
		L06A3	C16-4	Flow Divider/Combiner	180/47	420/6000	FC47-FC48
		L1A300	91-1	Flow Divider/Combiner	320/85	350/5000	FC49-FC50

☆ Denotes New Winner's Circle Product Line.



CV
Check Valves

SH
Shuttle Valves

LM
Load/Motor Controls

FC
Flow Controls

PC
Pressure Controls

LE
Logic Elements

DC
Directional Controls

MV
Manual Valves

SV
Solenoid Valves

PV
Proportional Valves

CE
Coils & Electronics

BC
Bodies & Cavities

TD
Technical Data

CV

Check Valves

SH

Shuttle Valves

LM

Load/Motor Controls

FC

Flow Controls

PC

Pressure Controls

LE

Logic Elements

DC

Directional Controls

MV

Manual Valves

SV

Solenoid Valves

PV

Proportional Valves

CE

Coils & Electronics

BC

Bodies & Cavities

TD

Technical Data

INTRODUCTION

This technical tips section is designed to help familiarize you with the Parker line of Flow Control Valves. In this section we present common options available as well as a brief synopsis of the operation and applications of the various product offered in this section. The intent of this section is to help you in selecting the best products for your application.

COMMON OPTIONS

As you will see, Parker offers a variety of Flow Control products. As such, some of the options mentioned below may not be available on all valve models. Consult the model coding and dimensions of each valve for specifics. Here are some of the common options available.

Adjustment Types: Parker offers four primary types of adjustments for most of the flow control products. Samples of these types are shown below. Please note all options may not be available for all valves. Consult the individual catalog pages for more details.

Screw Adjustment - Valve can be adjusted with an allen wrench. Lock nut included to maintain desired setting after adjustment. This is the most common adjustment option available on most Parker products.

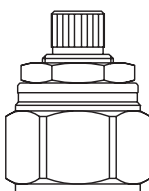

Knob Adjustment - An aluminum knob is added to the standard screw adjustment. A lock knob is provided to help maintain the desired setting after adjustment. Parker offers knob conversion kits for most flow control valves. For kit numbers consult the individual valve pages.

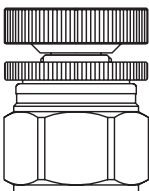

Fixed Style - In most cases, the Fixed Style product is a screw adjustable product with a steel collet threaded over the adjustment. These valves are preset at the factory. Should the valve need to be adjusted, the star washer and aluminum plate can be removed from the top of the assembly exposing the adjustment.

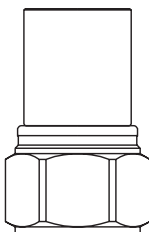
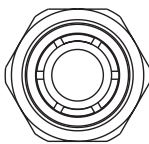

Tamper Resistant - The tamper resistant option is a screw adjustable valve with a steel cap installed to conceal the adjustment. The cap is designed so the internal edges clamp into the groove of the valve adapter. Once the cap is installed, it cannot be removed without damaging the cap and the valve.

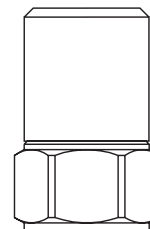

When a valve is ordered with the tamper resistant option, it will be preset at the factory, and the cap will be included in a separate plastic bag to allow for fine tuning at the customer site. Parker offers tamper resistant cap conversion kits for most flow control valves. For kit numbers consult the individual valve pages.

Seals: The Winner's Circle products feature a standard 4301 Polyurethane "D"-Ring. The "D"-Ring eliminates the need for backup rings. The majority of the products are available in Nitrile or Fluorocarbon Seals. You should match the seal compatibility to the temperature and fluid being used in your application.

Fine Meter Options: Fine meter needles are offered on some needle valve series. When this option is specified, the standard needle is replaced by a slotted needle. The slotted needle restricts substantially more flow giving you finer control in the small flow ranges. Obviously, the maximum flow capacity of the needle valve is decreased with the fine meter option.

Coarse Needle

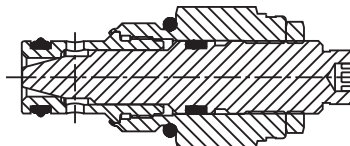

Fine Needle

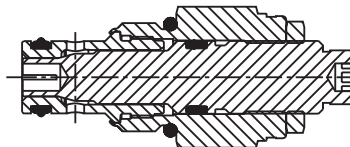

PRODUCT TYPES / APPLICATIONS

Needle Valve

Needle valves provide uncompensated adjustable flow control of a desired function. They are ideal for applications where general control of hydraulic flow is needed, like in a bleed off circuit.

When used with a compensator spool, a pressure compensated system can be obtained.

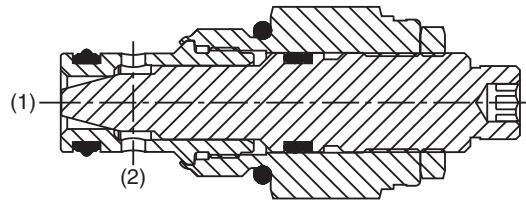
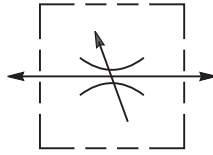

OPERATION - The valve acts as a fixed orifice in a hydraulic circuit. The effective size of the orifice increases as the tapered needle is opened. Shutoff is provided when fully closed. While a needle valve will meter flow regardless of the flow path, flow from port 2 to 1 is preferred. When you flow in the reverse direction (1 to 2), pressure forces work on the nose of the needle in an effort to drive it off of its seat. As such, all leakage conditions found in the catalog are based on flow from side to nose (port 2 to port 1). In addition, the adjustment will be harder to turn due to the added force.

Needle with a Reverse Check

Needle valves with reverse check functions are sometimes also referred to as flow control valves. As the name implies, these valves provide uncompensated adjustable speed control in one direction and allow free flow in the opposite direction. When used with a compensator spool, a pressure compensated system can be obtained.

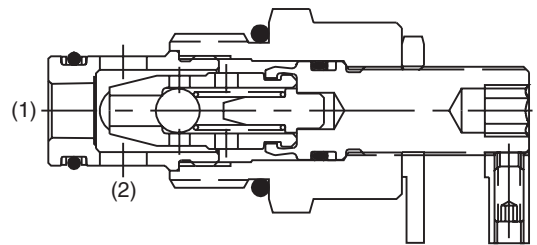
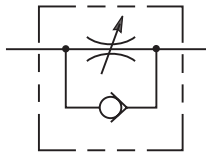

OPERATION - With flow entering the side of the cartridge (port 2), the needle acts as a fixed orifice. The effective size of this orifice is increased as the needle is opened controlling the output flow to port 1. With flow entering the nose (port 1), the check ball inside the needle is unseated allowing free flow to port 2.

P.C. Flow Regulator

Pressure compensated flow regulators maintain a regulated flow regardless of changes in load or inlet pressure. They are commonly used to accurately control an actuator function. They can be used in meter-in or meter-out applications.

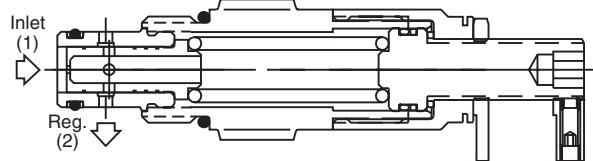
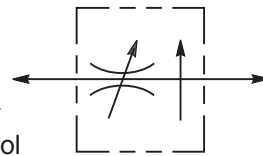

OPERATION - The valve consists of a control orifice within a normally open, spring biased compensator spool. Flow through the control orifice produces a pressure drop across the compensator spool. When inlet flow exceeds the flow setting of the valve, the force produced by the pressure differential across the spool exceeds the spring force and shifts the compensator spool to throttle or restrict flow; thus maintaining consistent flow through the valve. In the reverse direction, flow is metered, but not pressure compensated.

CV
Check Valves
SH
Shuttle Valves
LM
Load/Motor Controls
FC
Flow Controls
PC
Pressure Controls
LE
Logic Elements
DC
Directional Controls
MV
Manual Valves
SV
Solenoid Valves
PV
Proportional Valves
CE
Coils & Electronics
BC
Bodies & Cavities
TD
Technical Data

- CV Check Valves
- SH Shuttle Valves
- LM Load/Motor Controls
- FC Flow Controls
- PC Pressure Controls
- LE Logic Elements
- DC Directional Controls
- MV Manual Valves
- SV Solenoid Valves
- PV Proportional Valves
- CE Coils & Electronics
- BC Bodies & Cavities
- TD Technical Data

P.C. Flow Control

Pressure compensated flow controls are pressure compensated regulators with a reverse flow check valve. They provide constant regulated flow in the one direction regardless of changes in load pressure. Flow in the reverse direction is non-regulated, free flow. They can be used in meter-in or meter-out applications.

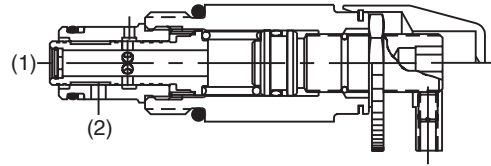
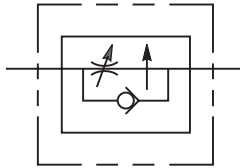

Adjustable Flow Controls

Most adjustable pressure compensated flow controls have a limited adjustment range. You will see in our catalog that we use the term “tuneable” for the FR101 and FC101 valves. This means they are only adjustable within a pre-set range. The FA101, J02E2, J04E2 and J04C2 are fully adjustable. Keep this adjustment capability in mind when you select a flow control.

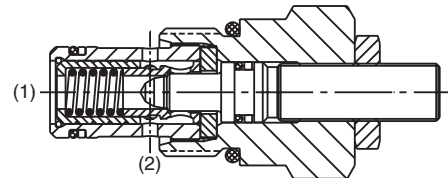
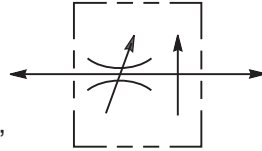

OPERATION - When flow enters the nose (port 1) of the cartridge, it passes through a control orifice. This control orifice creates a pressure differential across the regulating spool. As the inlet flow increases, the pressure differential across the regulating spool increases, allowing the regulating spool to overcome its spring force and begin to shift. As it shifts, it throttles to maintain a constant flow. When used in conjunction with a fixed displacement pump, a relief valve between pump and valve is needed. Full flow is allowed in the reverse direction (port 2 to 1).

Priority Style P.C. Flow Regulator

Priority style pressure compensator regulators maintain constant priority flow to one leg of the circuit regardless of changes in load or inlet pressure. Once this priority flow requirement is satisfied, the excess flow is diverted and can be used in another leg of the circuit. These valves are usually used in meter-in applications.

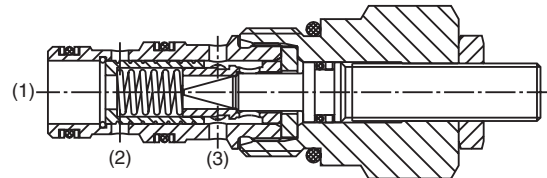
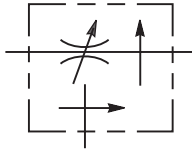

OPERATION - The valve consists of a control orifice within a spring biased compensator spool. The priority port is normally open while the bypass port is normally closed. As flow enters the inlet of the cartridge and passes through the control orifice, a pressure differential is created across the compensator spool. When the inlet flow exceeds the setting of the valve, the force produced by this pressure differential exceeds the spring force and shifts the compensator spool; opening up the bypass port, and bypassing the excess flow. If load pressure at the bypass port is greater than the load pressure at the priority port, the compensator spool will further shift restricting the priority flow to that of the valve setting. **Caution:** If the priority line is blocked so that no flow can pass through the control orifice, the compensator spool will shift, blocking the bypass port and allowing inlet pressure to go to full system relief pressure. These valves do not provide a pressure relieving function, so it is common to place an external relief valve downstream of port 3 to prevent a no flow condition.

Compensator Valves

Compensator valves are used to provide pressure compensated control across an external fixed or adjustable orifice. Parker offers both the restrictive type of compensator and a priority style.

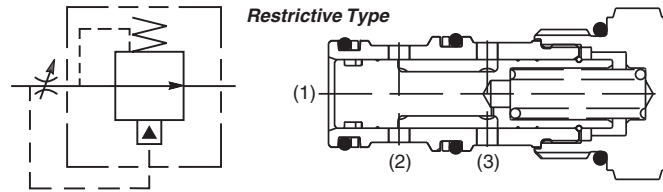

OPERATION - Restrictive Type:

Inlet flow (upstream of the orifice) is split with one portion going to the compensator port inlet (port 1), the other portion passes through the orifice to the supply port (port 3). As pressure drop across the orifice reaches the selected compensator pressure drop, the higher pressure (pre-orifice) at port 1 starts to shift the compensator spool into throttling position. The valve works to maintain a constant pressure drop across the orifice.

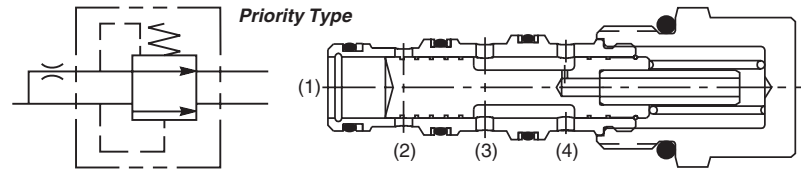

Priority Type: Flow through the external orifice into the supply port (port 4) produces a pressure drop across the compensator spool. When the inlet pressure exceeds the initial setting of the valve, the force produced by the pressure differential across the spool exceeds the spring force and shifts the compensator spool to throttle or restrict the flow, thus maintaining constant flow through the priority port (port 3). The excess flow is bypassed to port 2. Regulated port flow must be maintained for bypass flow to continue.

Flow Divider / Combiner

Flow divider / combiner valves are used to proportion the flow from a single source into two actuators. In the reverse mode, the valve takes the flow from the two sources and combines it into one flow.

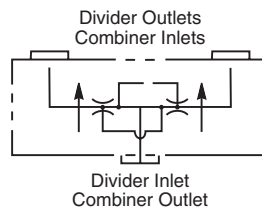

When attempting to synchronize two cylinders

with a flow/divider combiner valve, please consider that the flow accuracy is +10%.

A crossover relief can be used to help re-synchronize the cylinders by bottoming them out after several cycles.

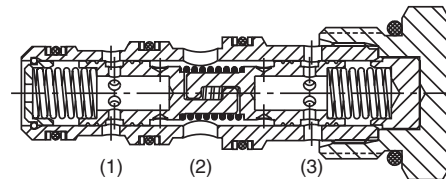

OPERATION - When flow enters the divider inlet port, it will pass through orifices in each of the interconnected spools. The flow passing through the orifices creates a pressure drop which pulls the two spools away from each other. The flow then passes to the two divider outlet ports. The division of flow (i.e. 50-50, 60-40, 66-33, etc.) is determined by the orifice sizes in the two spools. When flow is being combined, it enters the valve through two combiner inlets. The pressure drop across the orifices pulls the two spools together. The combined flow then passes through the combiner outlet.

- CV**
- Check Valves
- SH**
- Shuttle Valves
- LM**
- Load/Motor Controls
- FC**
- Flow Controls
- PC**
- Pressure Controls
- LE**
- Logic Elements
- DC**
- Directional Controls
- MV**
- Manual Valves
- SV**
- Solenoid Valves
- PV**
- Proportional Valves
- CE**
- Coils & Electronics
- BC**
- Bodies & Cavities
- TD**
- Technical Data

- CV** Check Valves
- SH** Shuttle Valves
- LM** Load/Motor Controls
- FC** Flow Controls
- PC** Pressure Controls
- LE** Logic Elements
- DC** Directional Controls
- MV** Manual Valves
- SV** Solenoid Valves
- PV** Proportional Valves
- CE** Coils & Electronics
- BC** Bodies & Cavities
- TD** Technical Data

General Description

Cartridge Style Needle Valve. For additional information see Technical Tips on pages FC1-FC4.

Features

- Shuts off to a very low leakage level
- High flow capacity from a small cavity
- Good adjustment sensitivity - ideal for fine control
- Good contamination tolerant
- Adjustable and tamperproof versions available
- All external parts zinc plated

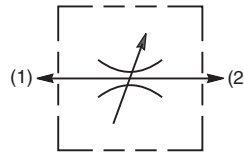
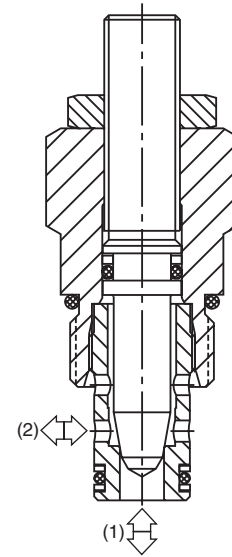
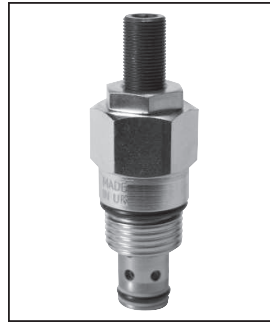

Specifications

Rated Flow	45 LPM (12 GPM)
Maximum Inlet Pressure	420 Bar (6000 PSI)
Cartridge Material	All parts steel. All operating parts hardened steel.
Operating Temp. Range/Seals	-40°C to +93.3°C (Nitrile) (-40°F to +200°F) -31.7°C to +121.1°C (Fluorocarbon) (-25°F to +250°F)
Fluid Compatibility/ Viscosity	Mineral-based or synthetic with lubricating properties at viscosities of 45 to 2000 SSU (6 to 420 cSt)
Filtration	ISO Code 16/13, SAE Class 4 or better
Approx. Weight	.11 kg (.24 lbs.)
Cavity	C08-2 (See BC Section for more details)
Form Tool	Rougher None Finisher NFT08-2F

Performance Curves (Through cartridge only)

Low Pressure Drop vs. Flow 1 to 2 & 2 to 1

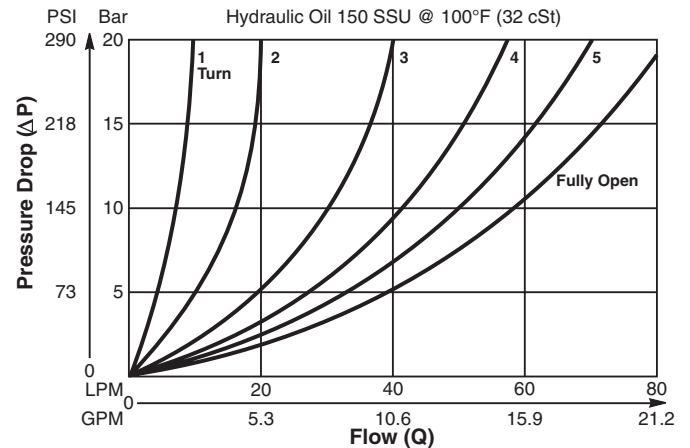

High Pressure Drop vs. Flow 1 to 2 & 2 to 1

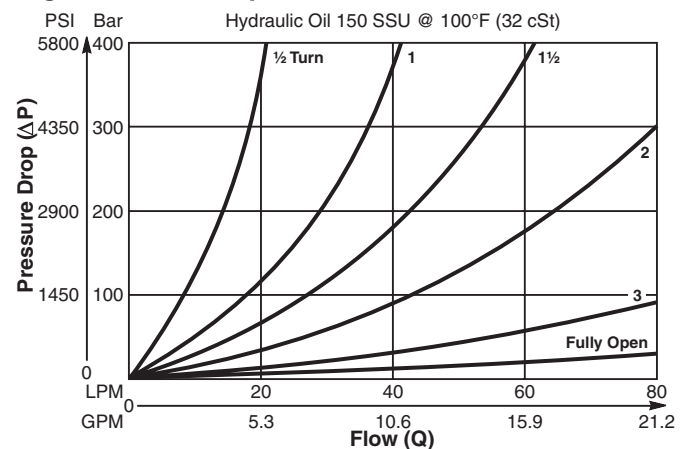

Dimensions Millimeters (Inches)

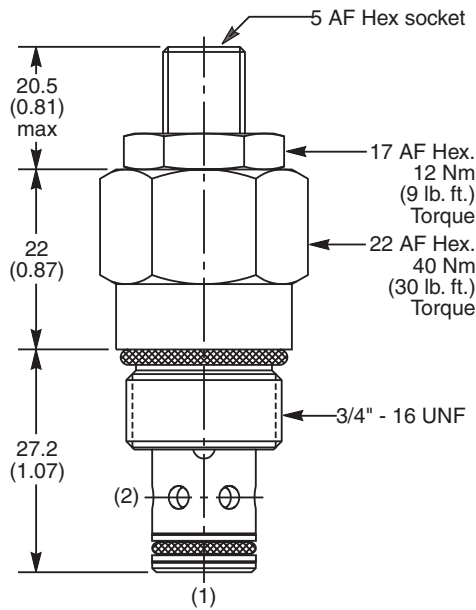

Ordering Information

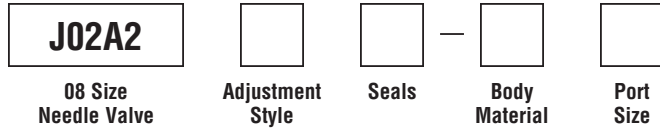

Code	Adjustment Style
Z	Screw Adjust (Std.)
W	Knob Adjust
T	Tamper Resistant Cap (TC1130)

Code	Seals / Kit. No.
N	Nitrile, Buna-N (Std.) / (SK30500N-1)
V	Fluorocarbon / (SK30500V-1)

Code	Body Material
Omit	Steel
A	Aluminum

Code	Port Size	Body Part No.
Omit	Cartridge Only	
4P	1/4" NPTF	(B08-2-*4P)
6P	3/8" NPTF	(B08-2-*6P)
4T	SAE-4	(B08-2-*4T)
6T	SAE-6	(B08-2-*6T)
6B	3/8" BSPG	(B08-2-*6B)

* Add "A" for aluminum, omit for steel.

Technical Information

- CV** Check Valves
- SH** Shuttle Valves
- LM** Load/Motor Controls
- FC** Flow Controls
- PC** Pressure Controls
- LE** Logic Elements
- DC** Directional Controls
- MV** Manual Valves
- SV** Solenoid Valves
- PV** Proportional Valves
- CE** Coils & Electronics
- BC** Bodies & Cavities
- TD** Technical Data

General Description

Cartridge Style Needle Valve.
For additional information see
Technical Tips on pages FC1-FC4.



Features

- Hardened, precision ground parts for durability
- Compact size for reduced space requirements
- Fine adjustment needle option available for precise adjustment
- Polyurethane “D”-Ring eliminates backup rings and prevents hydrolysis
- Valve meters flow in either direction, but (2 to 1) is the preferred direction for lowest leakage at shut off
- All external parts zinc plated

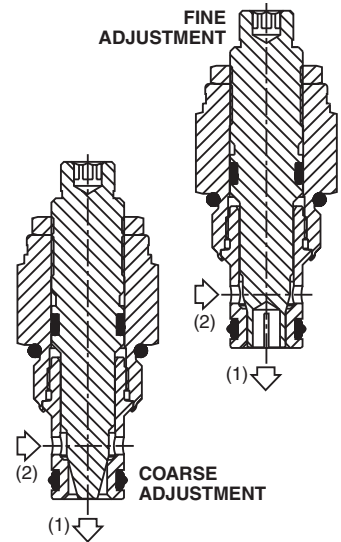
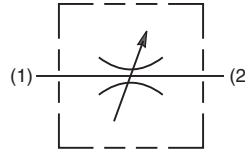

Specifications

Rated Flow	Fixed 37.9 LPM (10 GPM) Adjusted
Maximum Inlet Pressure	380 Bar (5500 PSI)
Cartridge Material	All parts steel. All operating parts hardened steel.
Operating Temp. Range/Seals	-45°C to +93.3°C (“D”-Ring) (-50°F to +200°F) -31.7°C to +121.1°C (Fluorocarbon) (-25°F to +250°F)
Fluid Compatibility/ Viscosity	Mineral-based or synthetic with lubricating properties at viscosities of 45 to 2000 SSU (6 to 420 cSt)
Filtration	ISO Code 16/13, SAE Class 4 or better
Approx. Weight	.10 kg (.20 lbs.)
Cavity	No. C08-2 (See BC Section for more details)
Form Tool	Rougher None Finisher NFT08-2F

Performance Curves

Flow vs. Inlet Pressure (Through cartridge only)

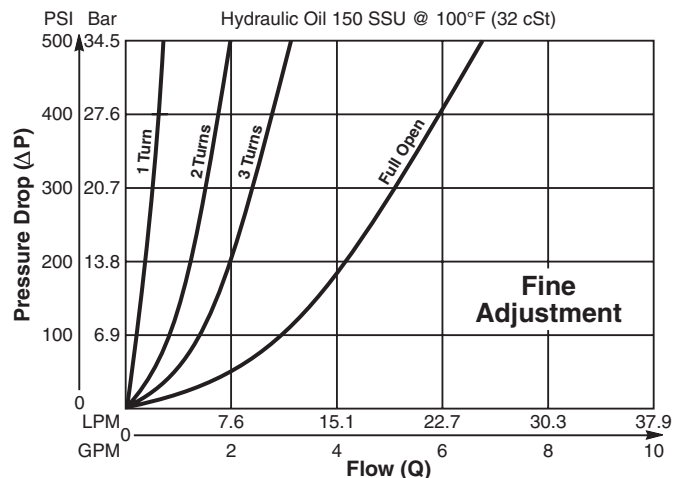
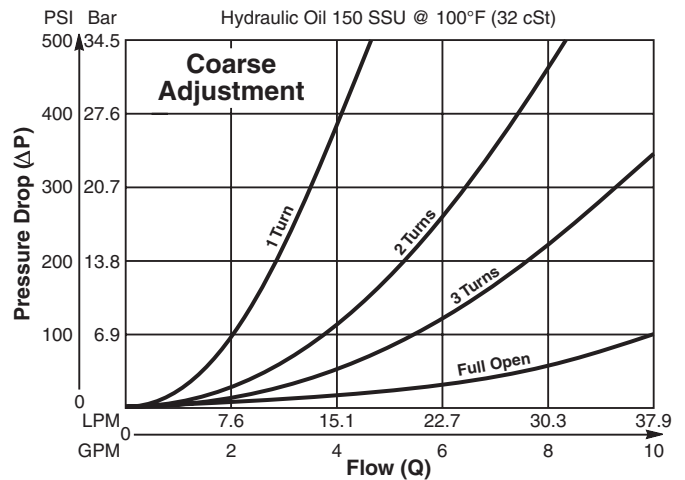

Dimensions Millimeters (Inches)

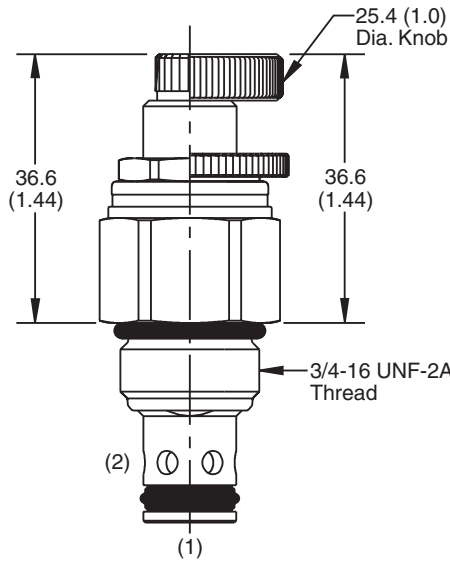

Screw/Knob Version

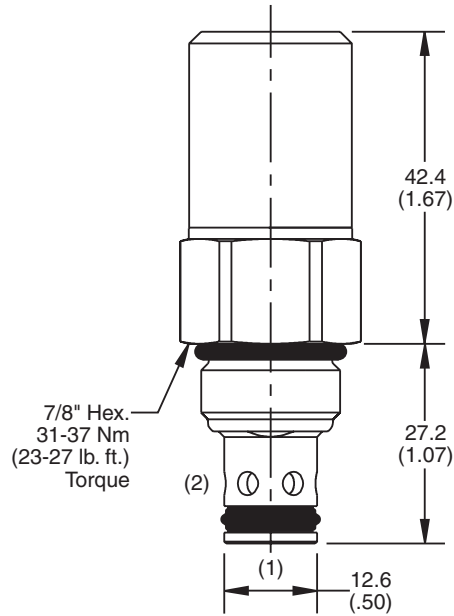

Tamper Resistant Version

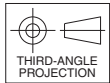

Ordering Information



Code	Flow Needle
Omit	Coarse
F	Fine

Code	Seals / Kit. No.
Omit	"D"-Ring / (SK08-2)
N	Nitrile / (SK08-2N)
V	Fluorocarbon / (SK08-2V)

Code	Body Material
Omit	Steel
A	Aluminum

Code	Port Size	Body Part No.
Omit	Cartridge Only	
4P	1/4" NPTF	(B08-2-*4P)
6P	3/8" NPTF	(B08-2-*6P)
4T	SAE-4	(B08-2-*4T)
6T	SAE-6	(B08-2-*6T)
6B	3/8" BSPG	(B08-2-*6B)

* Add "A" for aluminum, omit for steel.

Code	Adjustment Style
K	Knob Adjust (717784-10)
S	Screw Adjust
T	Tamper Resistant Cap (717943)

- CV**
Check Valves
- SH**
Shuttle Valves
- LM**
Load/Motor Controls
- FC**
Flow Controls
- PC**
Pressure Controls
- LE**
Logic Elements
- DC**
Directional Controls
- MV**
Manual Valves
- SV**
Solenoid Valves
- PV**
Proportional Valves
- CE**
Coils & Electronics
- BC**
Bodies & Cavities
- TD**
Technical Data

Technical Information

- CV Check Valves
- SH Shuttle Valves
- LM Load/Motor Controls
- FC Flow Controls
- PC Pressure Controls
- LE Logic Elements
- DC Directional Controls
- MV Manual Valves
- SV Solenoid Valves
- PV Proportional Valves
- CE Coils & Electronics
- BC Bodies & Cavities
- TD Technical Data

General Description

Cartridge Style Needle Valve. For additional information see Technical Tips on pages FC1-FC4.



Features

- Hardened, precision ground parts for durability
- Compact size for reduced space requirements
- Fine adjustment needle option available for precise adjustment
- Polyurethane "D"-Ring eliminates backup rings and prevents hydrolysis
- Valve meters flow in either direction, but (2 to 1) is the preferred direction for lowest leakage at shut off
- All external parts zinc plated

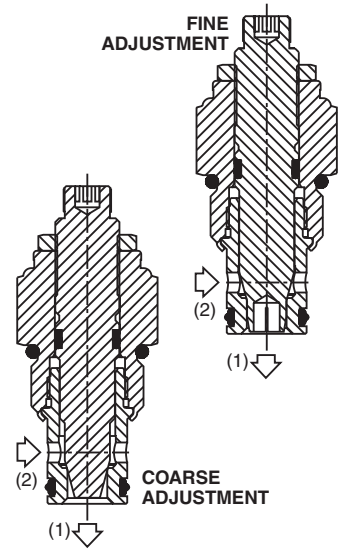
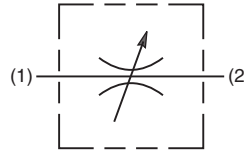
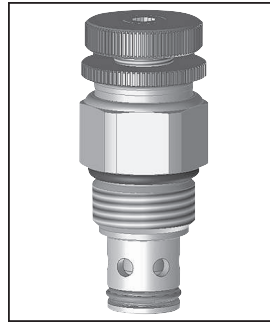

Specifications

Rated Flow	Fixed 60 LPM (16 GPM) Adjusted 60 LPM (16 GPM)
Maximum Inlet Pressure	380 Bar (5500 PSI)
Cartridge Material	All parts steel. All operating parts hardened steel.
Operating Temp. Range/Seals	-45°C to +93.3°C ("D"-Ring) (-50°F to +200°F) -31.7°C to +121.1°C (Fluorocarbon) (-25°F to +250°F)
Fluid Compatibility/Viscosity	Mineral-based or synthetic with lubricating properties at viscosities of 45 to 2000 SSU (6 to 420 cSt)
Filtration	ISO Code 16/13, SAE Class 4 or better
Approx. Weight	.18 kg (0.4 lbs.)
Cavity	C10-2 (See BC Section for more details)
Form Tool	Rougher None Finisher NFT10-2F

Performance Curves

Flow vs. Inlet Pressure (Through cartridge only)

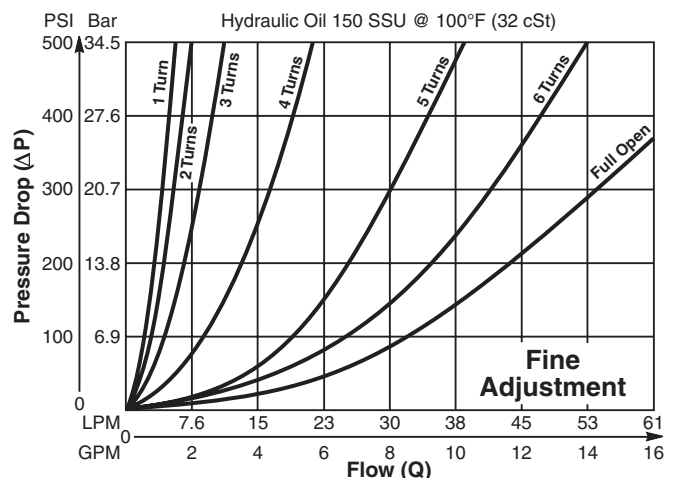
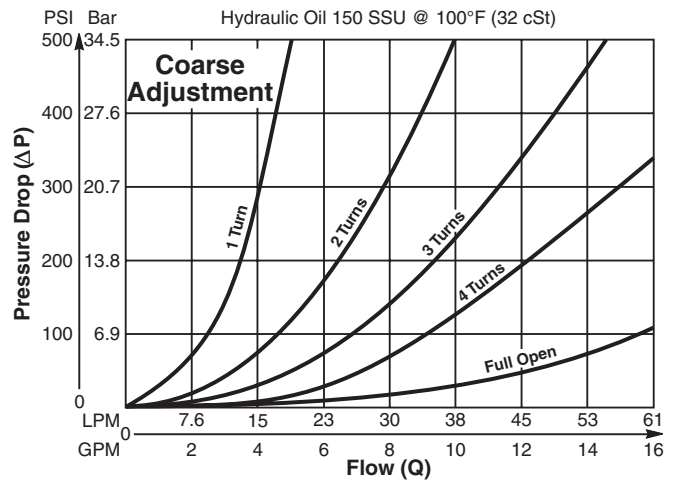

Dimensions Millimeters (Inches)

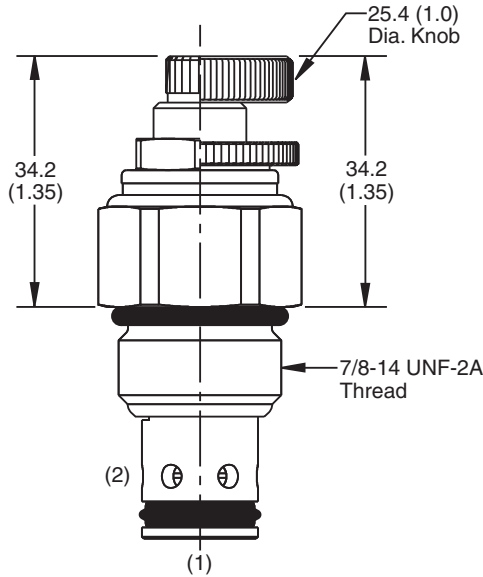

Screw/Knob Version

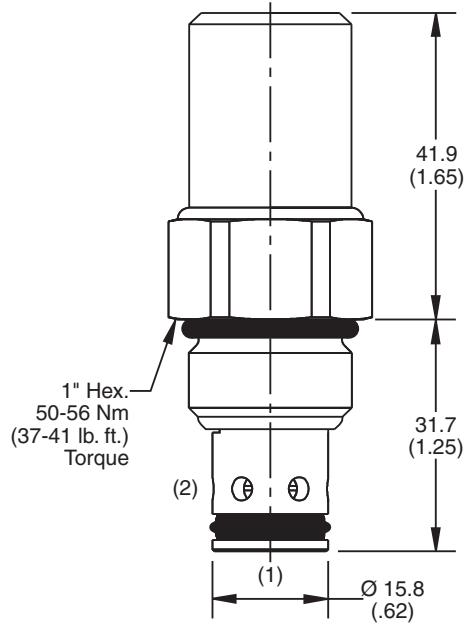

Tamper Resistant Version

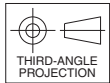

Ordering Information



Code	Flow Needle
Omit	Coarse
F	Fine

Code	Seals / Kit. No.
Omit	"D"-Ring / (SK10-2)
N	Nitrile / (SK10-2N)
V	Fluorocarbon / (SK10-2V)

Code	Body Material
Omit	Steel
A	Aluminum

Code	Port Size	Body Part No.
Omit	Cartridge Only	
4P	1/4" NPTF	(B10-2-*4P)
6P	3/8" NPTF	(B10-2-*6P)
8P	1/2" NPTF	(B10-2-*8P)
6T	SAE-6	(B10-2-*6T)
8T	SAE-8	(B10-2-*8T)
T8T	SAE-8	(B10-2-T8T)†
6B	3/8" BSPG	(B10-2-*6B)

Code	Adjustment Style
K	Knob Adjust (717784-10)
S	Screw Adjust
T	Tamper Resistant Cap (717943)

* Add "A" for aluminum, omit for steel.
 † Steel body only.

- CV**
Check Valves
- SH**
Shuttle Valves
- LM**
Load/Motor Controls
- FC**
Flow Controls
- PC**
Pressure Controls
- LE**
Logic Elements
- DC**
Directional Controls
- MV**
Manual Valves
- SV**
Solenoid Valves
- PV**
Proportional Valves
- CE**
Coils & Electronics
- BC**
Bodies & Cavities
- TD**
Technical Data

- CV** Check Valves
- SH** Shuttle Valves
- LM** Load/Motor Controls
- FC** Flow Controls
- PC** Pressure Controls
- LE** Logic Elements
- DC** Directional Controls
- MV** Manual Valves
- SV** Solenoid Valves
- PV** Proportional Valves
- CE** Coils & Electronics
- BC** Bodies & Cavities
- TD** Technical Data

General Description

Cartridge Style Needle Valve. For additional information see Technical Tips on pages FC1-FC4.

Features

- Shuts off to a very low leakage level
- High flow capacity
- Good adjustment sensitivity - ideal for fine control
- Good contamination tolerant
- Adjustable and tamperproof versions available
- All external parts zinc plated

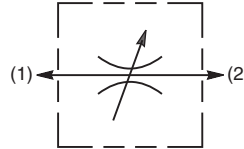
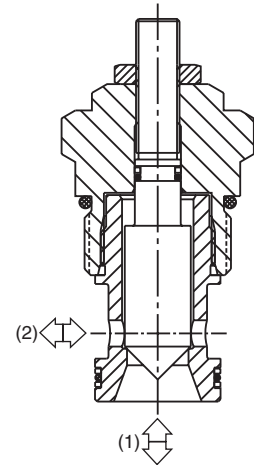
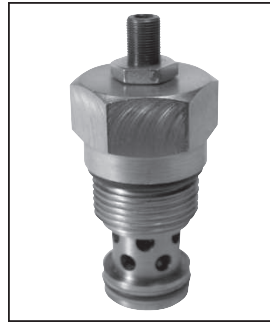

Specifications

Rated Flow	225 LPM (60 GPM)
Maximum Inlet Pressure	420 Bar (6000 PSI)
Cartridge Material	All parts steel. All operating parts hardened steel.
Operating Temp. Range/Seals	-40°C to +93.3°C (Nitrile) (-40°F to +200°F) -31.7°C to +121.1°C (Fluorocarbon) (-25°F to +250°F)
Fluid Compatibility/Viscosity	Mineral-based or synthetic with lubricating properties at viscosities of 45 to 2000 SSU (6 to 420 cSt)
Filtration	ISO Code 16/13, SAE Class 4 or better
Approx. Weight	.38 kg (.84 lbs.)
Cavity	C16-2 (See BC Section for more details)
Form Tool	Rougher None Finisher NFT16-2F

Performance Curves (Through cartridge only)

Low Pressure Drop vs. Flow 1 to 2 & 2 to 1

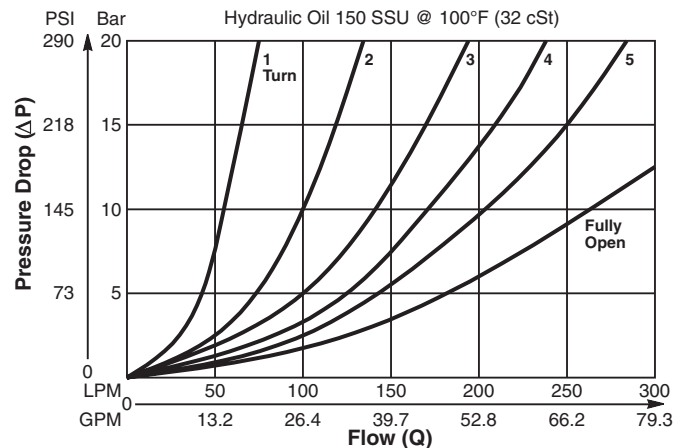

High Pressure Drop vs. Flow 1 to 2 & 2 to 1

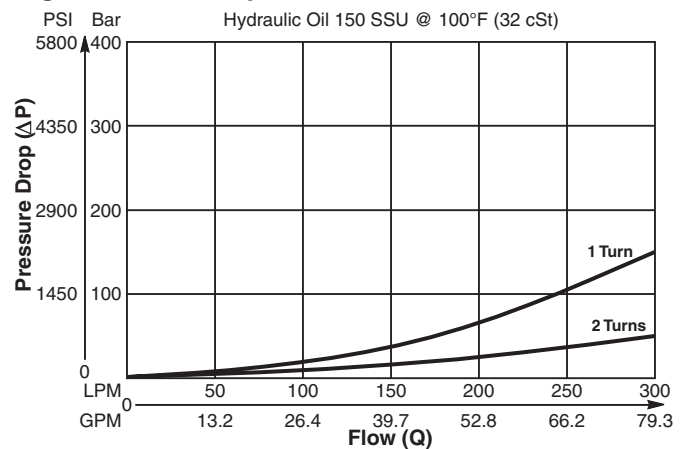

Dimensions Millimeters (Inches)

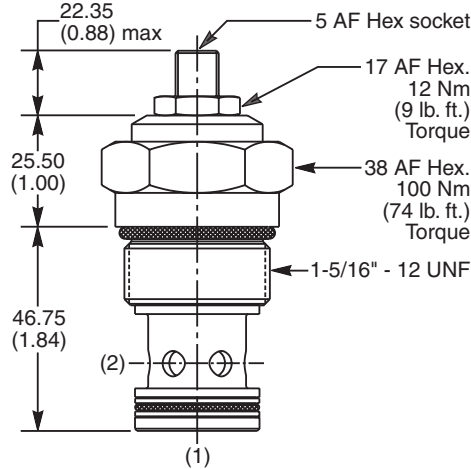

Ordering Information

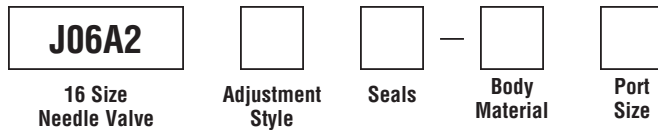

Code	Adjustment Style
Z	Screw Adjust (Std.)
W	Knob Adjust
T	Tamper Resistant Cap (TC1130)

Code	Seals / Kit. No.
N	Nitrile, Buna-N (Std.) / (SK30507N-1)
V	Fluorocarbon / (SK30507V-1)

Code	Body Material
Omit	Steel
A	Aluminum

Code	Port Size	Body Part No.
Omit	Cartridge Only	
12P	3/4" NPTF	(B16-2-*12P)
16P	1" NPTF	(B16-2-*16P)
8T	SAE-8	(B16-2-*8T)
12T	SAE-12	(B16-2-*12T)
16T	SAE-16	(B16-2-*16T)
12B	3/4" BSPG	(B16-2-12B)†
16B	1" BSPG	(B16-2-*16B)

* Add "A" for aluminum, omit for steel.
 † Steel body only.

- CV** Check Valves
- SH** Shuttle Valves
- LM** Load/Motor Controls
- FC** Flow Controls
- PC** Pressure Controls
- LE** Logic Elements
- DC** Directional Controls
- MV** Manual Valves
- SV** Solenoid Valves
- PV** Proportional Valves
- CE** Coils & Electronics
- BC** Bodies & Cavities
- TD** Technical Data

General Description

Poppet Type Needle Valve with Reverse Flow Check. For additional information see Technical Tips on pages FC1-FC4.

Features

- Shuts off to a very low leakage level
- Good adjustment sensitivity - ideal for fine control
- Good contamination tolerant
- Adjustable and tamperproof versions available
- All external parts zinc plated

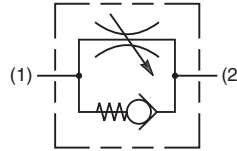
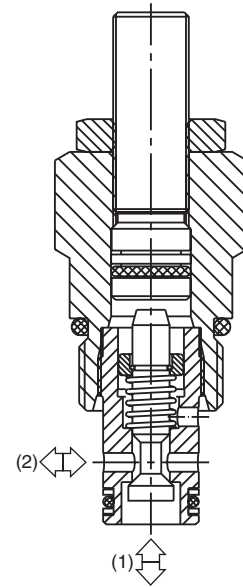
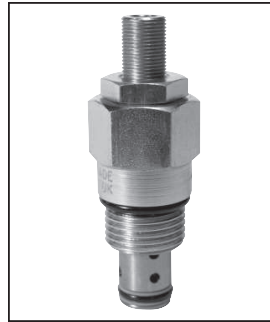

Specifications

Rated Flow	30 LPM (8 GPM)
Maximum Inlet Pressure	420 Bar (6000 PSI)
Cartridge Material	All parts steel. All operating parts hardened steel.
Operating Temp. Range/Seals	-40°C to +93.3°C (Nitrile) (-40°F to +200°F) -31.7°C to +121.1°C (Fluorocarbon) (-25°F to +250°F)
Fluid Compatibility/ Viscosity	Mineral-based or synthetic with lubricating properties at viscosities of 45 to 2000 SSU (6 to 420 cSt)
Filtration	ISO Code 16/13, SAE Class 4 or better
Approx. Weight	.11 kg (.24 lbs.)
Cavity	C08-2 (See BC Section for more details)
Form Tool	Rougher Finisher None None NFT08-2F

Performance Curves (Through cartridge only)

Low Pressure Drop vs. Flow 1 to 2 & 2 to 1

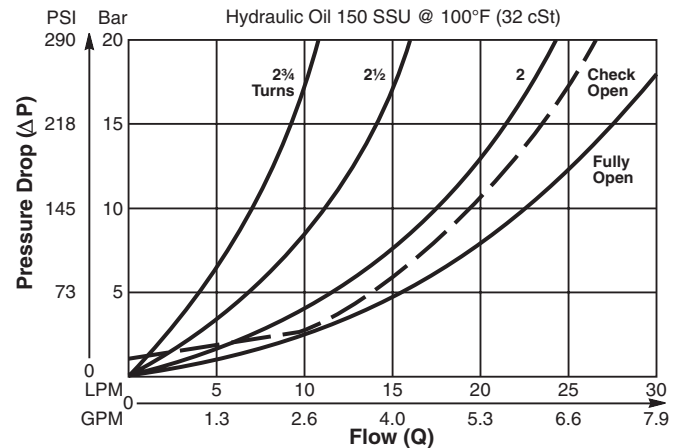

High Pressure Drop vs. Flow 1 to 2

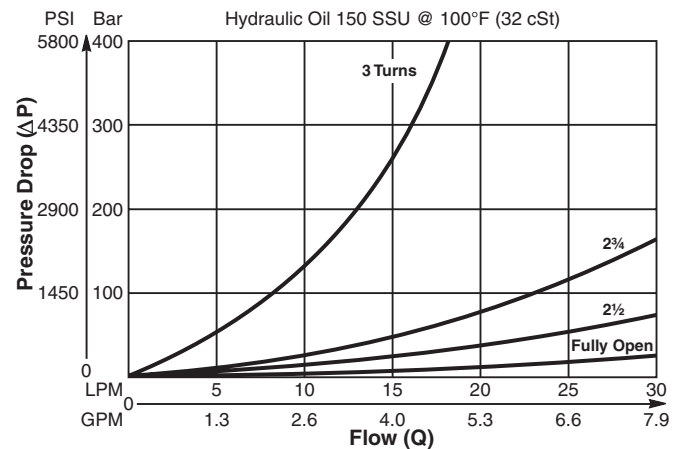

Dimensions Millimeters (Inches)

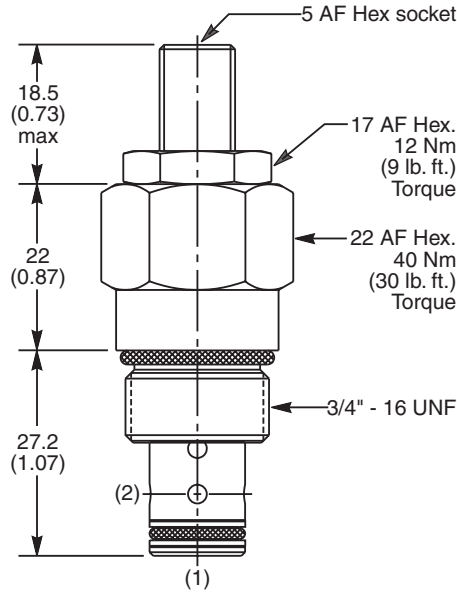

Ordering Information

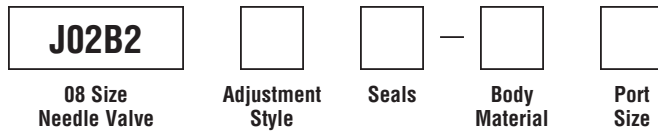

Code	Adjustment Style
Z	Screw Adjust (Std.)
W	Knob Adjust
T	Tamper Resistant Cap (TC1130)

Code	Seals / Kit. No.
N	Nitrile, Buna-N (Std.) / (SK30500N-1)
V	Fluorocarbon / (SK30500V-1)

Code	Body Material
Omit	Steel
A	Aluminum

Code	Port Size	Body Part No.
Omit	Cartridge Only	
4P	1/4" NPTF	(B08-2-*4P)
6P	3/8" NPTF	(B08-2-*6P)
4T	SAE-4	(B08-2-*4T)
6T	SAE-6	(B08-2-*6T)
6B	3/8" BSPG	(B08-2-*6B)

* Add "A" for aluminum, omit for steel.

Technical Information

- CV** Check Valves
- SH** Shuttle Valves
- LM** Load/Motor Controls
- FC** Flow Controls
- PC** Pressure Controls
- LE** Logic Elements
- DC** Directional Controls
- MV** Manual Valves
- SV** Solenoid Valves
- PV** Proportional Valves
- CE** Coils & Electronics
- BC** Bodies & Cavities
- TD** Technical Data

General Description

Needle Valve with a Reverse Check. Also known as a Flow Control Valve. For additional information see Technical Tips on pages FC1-FC4.

Features

- Hardened, precision ground parts for durability
- Compact size for reduced space requirements
- Fine thread needle option available for precise adjustment
- All external parts zinc plated

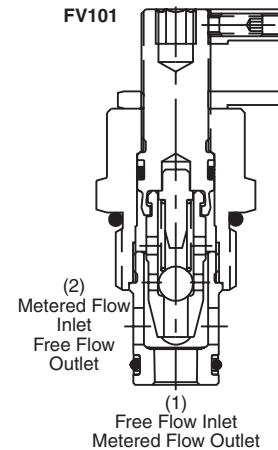
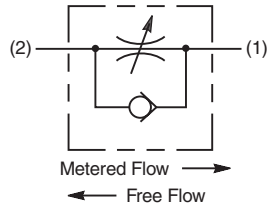
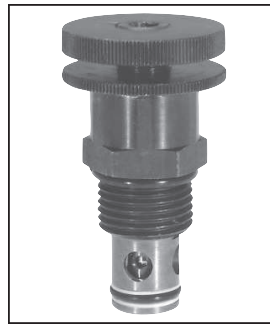

Specifications

Rated Flow	FV101 45 LPM (12 GPM) FV102 23 LPM (6 GPM)
Maximum Inlet Pressure	210 Bar (3000 PSI)
Cartridge Material	All parts steel. All operating parts hardened steel.
Operating Temp. Range/Seals	-40°C to +93.3°C (Nitrile) (-40°F to +200°F) -31.7°C to +121.1°C (Fluorocarbon) (-25°F to +250°F)
Fluid Compatibility/ Viscosity	Mineral-based or synthetic with lubricating properties at viscosities of 45 to 2000 SSU (6 to 420 cSt)
Filtration	ISO Code 16/13, SAE Class 4 or better
Approx. Weight	.23 kg (0.5 lbs.)
Cavity	C10-2 (See BC Section for more details)
Form Tool	Rougher None Finisher NFT10-2F

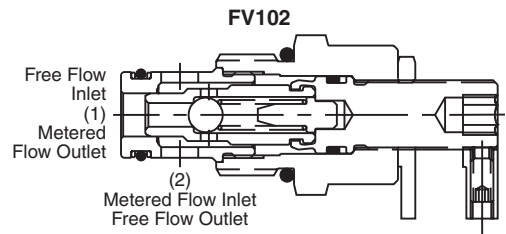

Dimensions Millimeters (Inches)

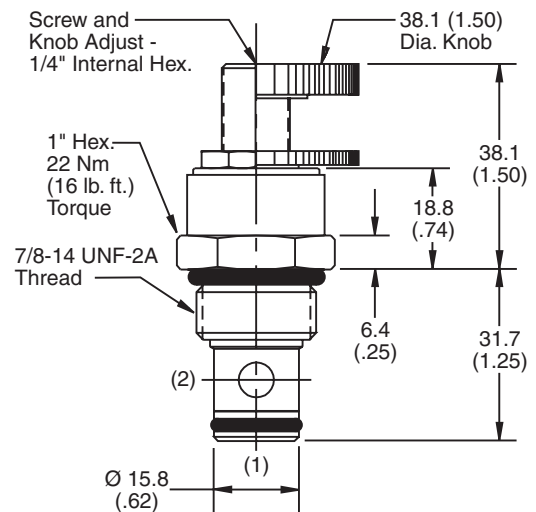

Performance Curves

Metered Flow vs. Pressure Drop (Through cartridge only)

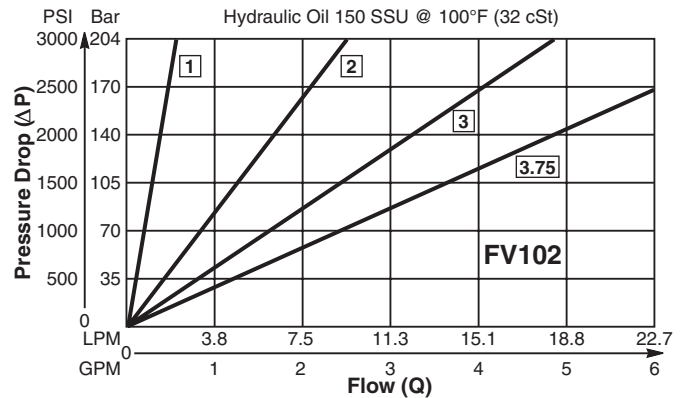
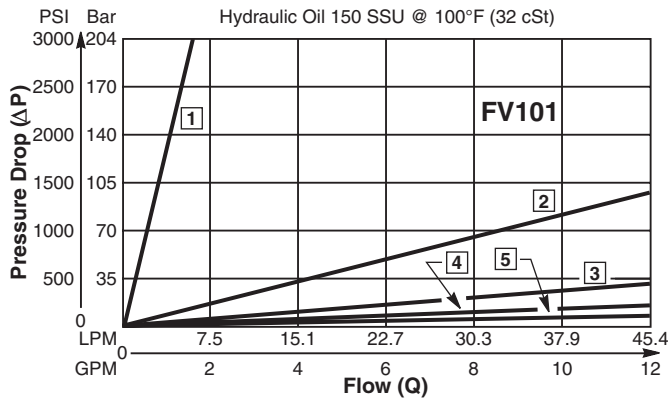

□ = No. of Turns CCW From Fully Closed.

The number on each curve indicates the number of complete turns of the knob or screw adjustment from fully closed. When the metered flow is 22.5 LPM (6 GPM) and the adjustment is two complete turns from closed, the pressure drop will be 13.8 Bar (200 PSI). When the metered flow is 22.5 LPM (6 GPM) and the adjustment is five complete turns from closed, the pressure drop will be 3.5 Bar (50 PSI).

□ = No. of Turns CCW From Fully Closed.

The number on each curve indicates the number of complete turns of the knob or screw adjustment from fully closed (non-metered flow). When the metered flow is 7.5 LPM (2 GPM) and the adjustment is two complete turns from closed, the pressure drop will be 156.9 Bar (2275 PSI). When the metered flow is 7.5 LPM (2 GPM) and the adjustment is 3.75 turns from closed, the pressure drop will be 56.6 Bar (820 PSI).

Ordering Information



Code	Style
1	Coarse Flow
2	Fine Flow

Code	Seals / Kit. No.
Omit	Nitrile / (SK10-2N)
V	Fluorocarbon / (SK10-2V)

Code	Body Material
Omit	Steel
A	Aluminum

Code	Adjustment Style
K	Knob Adjust (840208K)
S	Screw Adjust

Code	Port Size	Body Part No.
Omit	Cartridge Only	
4P	1/4" NPTF	(B10-2-*4P)
6P	3/8" NPTF	(B10-2-*6P)
8P	1/2" NPTF	(B10-2-*8P)
6T	SAE-6	(B10-2-*6T)
8T	SAE-8	(B10-2-*8T)
T8T	SAE-8	(B10-2-T8T)†
6B	3/8" BSPG	(B10-2-6B)†

* Add "A" for aluminum, omit for steel.
 † Steel body only.

Technical Information

- CV** Check Valves
- SH** Shuttle Valves
- LM** Load/Motor Controls
- FC** Flow Controls
- PC** Pressure Controls
- LE** Logic Elements
- DC** Directional Controls
- MV** Manual Valves
- SV** Solenoid Valves
- PV** Proportional Valves
- CE** Coils & Electronics
- BC** Bodies & Cavities
- TD** Technical Data

General Description

Restrictive Style, Pressure Compensated Flow Control Valve. For additional information see Technical Tips on pages FC1-FC4.

Features

- Minimal flow change with pressure variation
- Reverse flow function
- Full adjustment from 1-20 LPM (0.3-5.3 GPM)
- Hardened working parts for maximum durability
- Adjustable and tamperproof versions available
- All external parts zinc plated

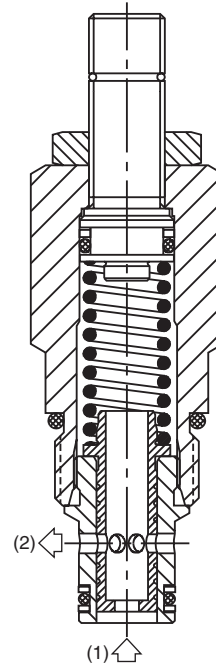
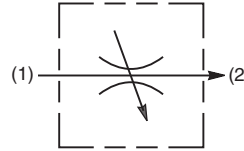

Specifications

Rated Flow	20 LPM (5.3 GPM)
Maximum Inlet Pressure	420 Bar (6000 PSI)
Cartridge Material	All parts steel. All operating parts hardened steel.
Operating Temp. Range/Seals	-40°C to +93.3°C (Nitrile) (-40°F to +200°F) -31.7°C to +121.1°C (Fluorocarbon) (-25°F to +250°F)
Fluid Compatibility/ Viscosity	Mineral-based or synthetic with lubricating properties at viscosities of 45 to 2000 SSU (6 to 420 cSt)
Filtration	ISO Code 16/13, SAE Class 4 or better
Approx. Weight	.13 kg (.29 lbs.)
Cavity	C08-2 (See BC Section for more details)
Form Tool	Rougher None Finisher NFT08-2F

Performance Curves (Through cartridge only)

Flow Regulating Performance

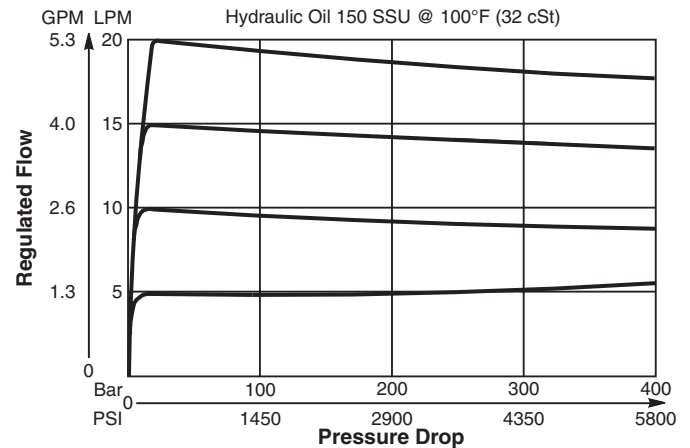

Reverse Flow Pressure Drop vs. Flow

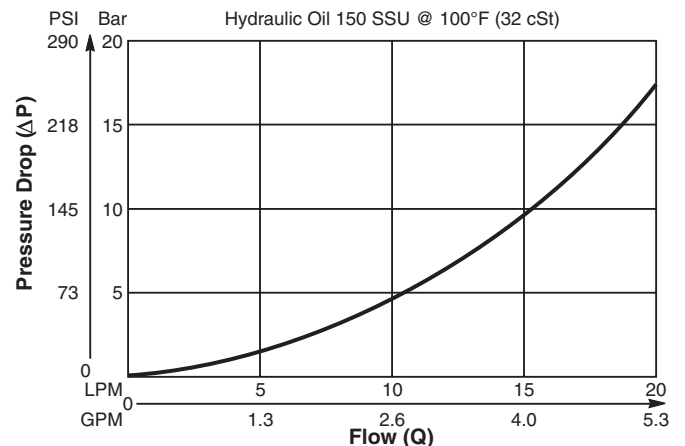

Dimensions Millimeters (Inches)

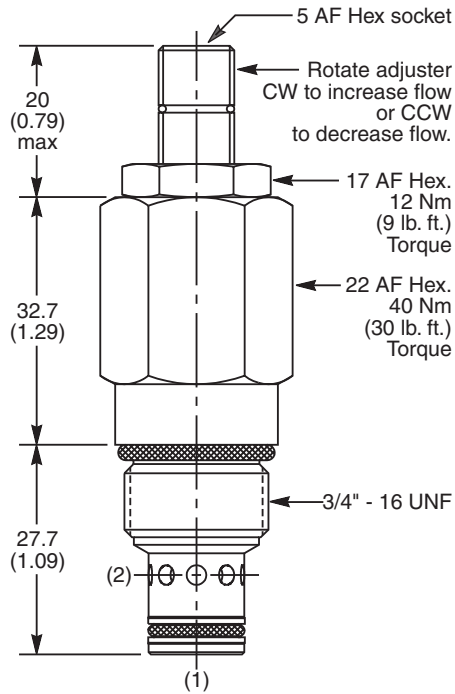

Ordering Information

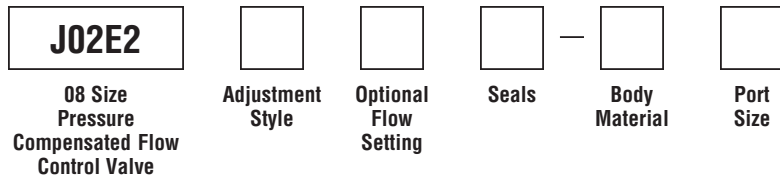

Code	Adjustment Style
Z	Screw Adjust (Std.)
W	Knob Adjust
T	Tamper Resistant Cap (TC1130)

Code	Seals / Kit. No.
N	Nitrile, Buna-N (Std.) / (SK30500N-1)
V	Fluorocarbon / (SK30500V-1)

Code	Body Material
Omit	Steel
A	Aluminum

Code	Port Size	Body Part No.
Omit	Cartridge Only	
4P	1/4" NPTF	(B08-2-*4P)
6P	3/8" NPTF	(B08-2-*6P)
4T	SAE-4	(B08-2-*4T)
6T	SAE-6	(B08-2-*6T)
6B	3/8" BSPG	(B08-2-*6B)

* Add "A" for aluminum, omit for steel.

Code	Optional Flow Setting
Omit	Omit for no setting* Specify setting if required (LPM)

* Appropriate mid-range setting for Standard = 10 LPM

- CV**
Check Valves
- SH**
Shuttle Valves
- LM**
Load/Motor Controls
- FC**
Flow Controls
- PC**
Pressure Controls
- LE**
Logic Elements
- DC**
Directional Controls
- MV**
Manual Valves
- SV**
Solenoid Valves
- PV**
Proportional Valves
- CE**
Coils & Electronics
- BC**
Bodies & Cavities
- TD**
Technical Data

Technical Information

- CV** Check Valves
- SH** Shuttle Valves
- LM** Load/Motor Controls
- FC** Flow Controls
- PC** Pressure Controls
- LE** Logic Elements
- DC** Directional Controls
- MV** Manual Valves
- SV** Solenoid Valves
- PV** Proportional Valves
- CE** Coils & Electronics
- BC** Bodies & Cavities
- TD** Technical Data

General Description

Pressure Compensated Flow Regulator Valve.
NOTE: When used with a fixed displacement pump, pressure to the cartridge must be controlled by a relief valve located between the pump and the FR101 cartridge. For additional information see Technical Tips on pages FC1-FC4.

Features

- Hardened, precision ground parts for durability
- Cartridge design
- Acts as a fixed orifice in reverse flow condition
- All external parts zinc plated

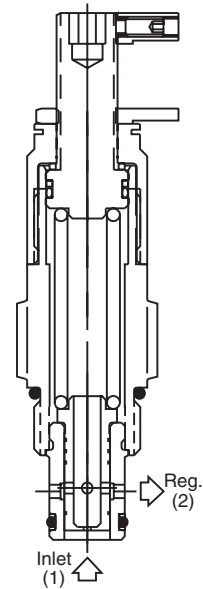
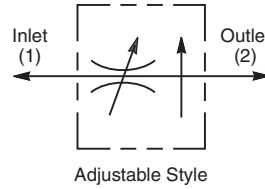
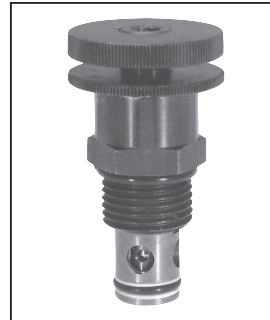

Specifications

Rated Flow	Fixed 22.5 LPM (6 GPM) Adjusted 26.5 LPM (7 GPM)
Maximum Inlet Pressure	245 Bar (3500 PSI)
Accuracy (Fixed)	3.8 LPM (1 GPM) ±20% 7.5 - 11.3 LPM (2-3 GPM) ±15% 15 - 22.5 LPM (4-6 GPM) ±10%
Adjustment Range (Adj. Version)	±30% Nominal
Cartridge Material	All parts steel. All operating parts hardened steel.
Operating Temp. Range/Seals	-40°C to +93.3°C (Nitrile) (-40°F to +200°F) -31.7°C to +121.1°C (Fluorocarbon) (-25°F to +250°F)
Fluid Compatibility/Viscosity	Mineral-based or synthetic with lubricating properties at viscosities of 45 to 2000 SSU (6 to 420 cSt)
Filtration	ISO Code 16/13, SAE Class 4 or better
Approx. Weight	.23 kg (0.5 lbs.)
Cavity	No. C10-2 (See BC Section for more details)
Form Tool	Rougher None Finisher NFT10-2F

Performance Curves
Regulated Flow vs. Pressure
(Through cartridge only)

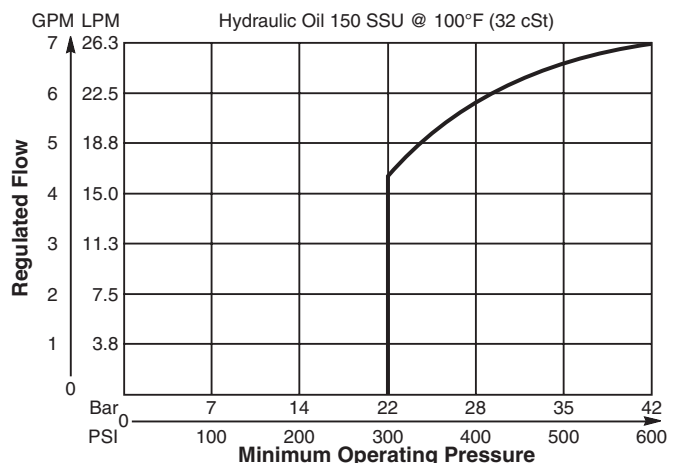
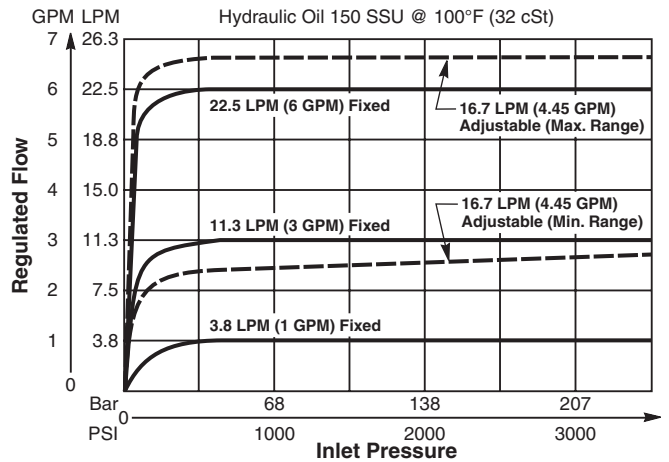

Dimensions Millimeters (Inches)

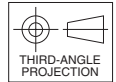
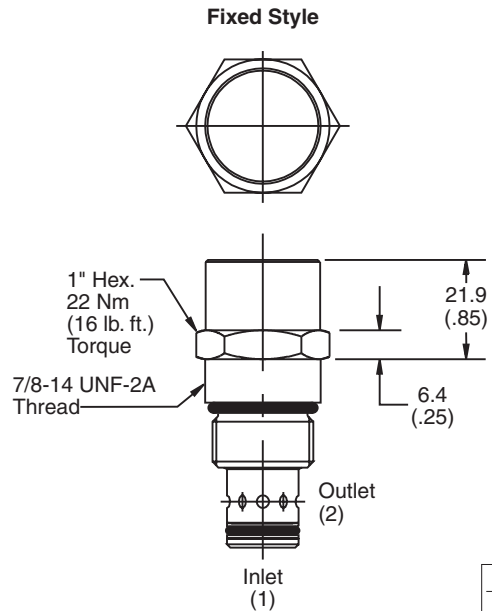
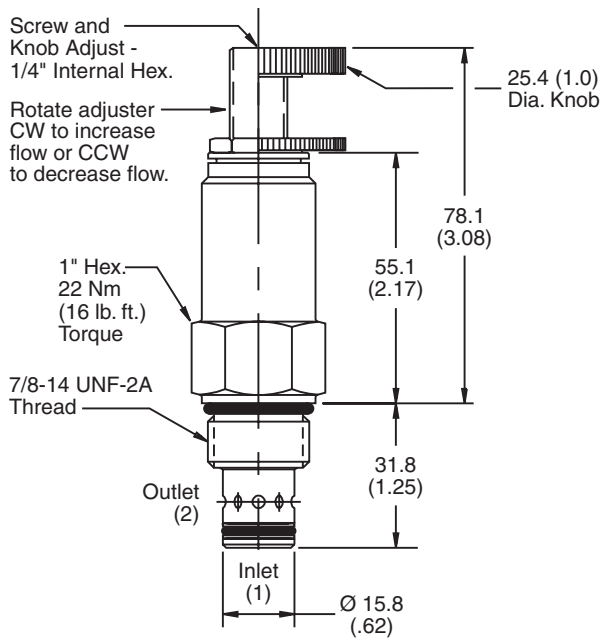

Ordering Information

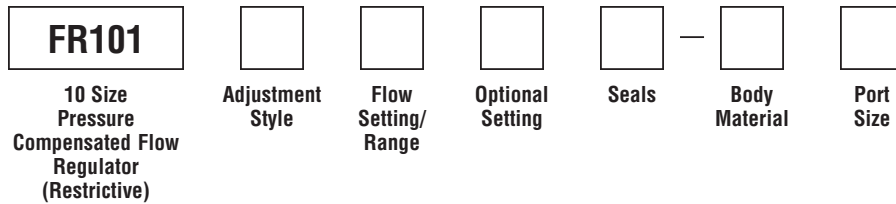

Code	Adjustment Style
F	Fixed Style present at factory
K	Knob Adjust
S	Screw Adjust

Code	Fixed Style Flow
100	3.8 LPM (1 GPM)
200	7.5 LPM (2 GPM)
300	11.3 LPM (3 GPM)
400	15 LPM (4 GPM)
500	18.8 LPM (5 GPM)
600	22.5 LPM (6 GPM)

Optional Setting
Flow setting specified in .38 LPM (.1 GPM) increments other than standard

Code	Seals / Kit. No.
Omit	Nitrile / (SK10-2N)
V	Fluorocarbon / (SK10-2V)

Code	Body Material
Omit	Steel
A	Aluminum

Code	Knob/Screw Style Flow Range
065	1.9-3.0 LPM (0.5-0.8 GPM)
095	3.0-4.5 LPM (0.8-1.2 GPM)
135	4.1-6.4 LPM (1.1-1.7 GPM)
185	6.0-8.3 LPM (1.6-2.2 GPM)
260	7.9-11.6 LPM (2.1-3.1 GPM)
375	11.3-16.9 LPM (3.0-4.5 GPM)
550	16.1-25.1 LPM (4.3-6.7 GPM)

Code	Port Size	Body Part No.
Omit	Cartridge Only	
4P	1/4" NPTF	(B10-2-*4P)
6P	3/8" NPTF	(B10-2-*6P)
8P	1/2" NPTF	(B10-2-*8P)
6T	SAE-6	(B10-2-*6T)
8T	SAE-8	(B10-2-*8T)
T8T	SAE-8	(B10-2-T8T)†
6B	3/8" BSPG	(B10-2-6B)†

* Add "A" for aluminum, omit for steel.
 † Steel body only.

Technical Information

- CV** Check Valves
- SH** Shuttle Valves
- LM** Load/Motor Controls
- FC** Flow Controls
- PC** Pressure Controls
- LE** Logic Elements
- DC** Directional Controls
- MV** Manual Valves
- SV** Solenoid Valves
- PV** Proportional Valves
- CE** Coils & Electronics
- BC** Bodies & Cavities
- TD** Technical Data

General Description

Restrictive Style, Pressure Compensated Flow Control Valve. For additional information see Technical Tips on pages FC1-FC4.

Features

- Minimal flow change with pressure variation
- Reverse flow function
- Full adjustment from 1-40 LPM (0.3-10.6 GPM)
- Hardened working parts for maximum durability
- Adjustable and tamperproof versions available
- All external parts zinc plated

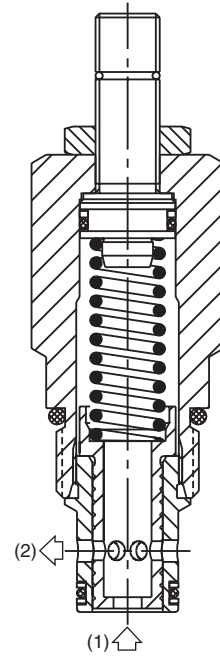
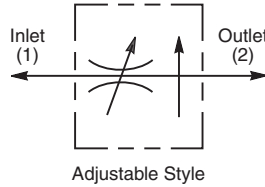
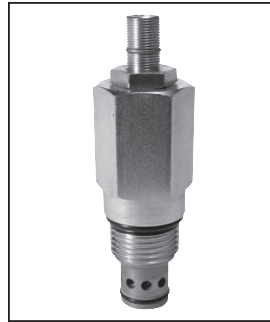

Specifications

Rated Flow	40 LPM (10.6 GPM)
Maximum Inlet Pressure	420 Bar (6000 PSI)
Cartridge Material	All parts steel. All operating parts hardened steel.
Operating Temp. Range/Seals	-40°C to +93.3°C (Nitrile) (-40°F to +200°F) -31.7°C to +121.1°C (Fluorocarbon) (-25°F to +250°F)
Fluid Compatibility/Viscosity	Mineral-based or synthetic with lubricating properties at viscosities of 45 to 2000 SSU (6 to 420 cSt)
Filtration	ISO Code 16/13, SAE Class 4 or better
Approx. Weight	.20 kg (.44 lbs.)
Cavity	C10-2 (See BC Section for more details)
Form Tool	Rougher None Finisher NFT10-2F

Performance Curves (Through cartridge only)

Flow Regulating Performance

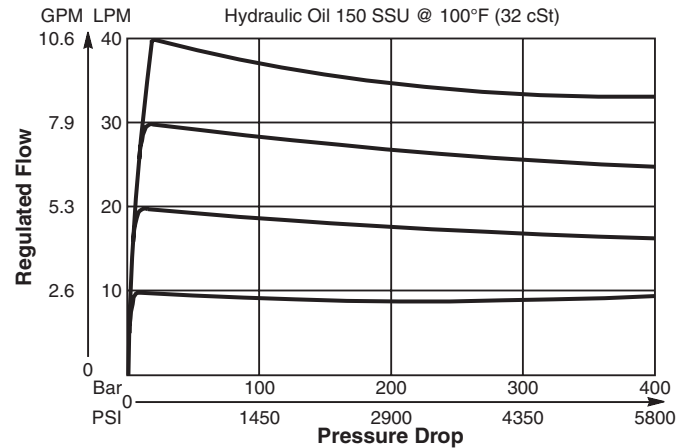

Reverse Flow Pressure Drop vs. Flow

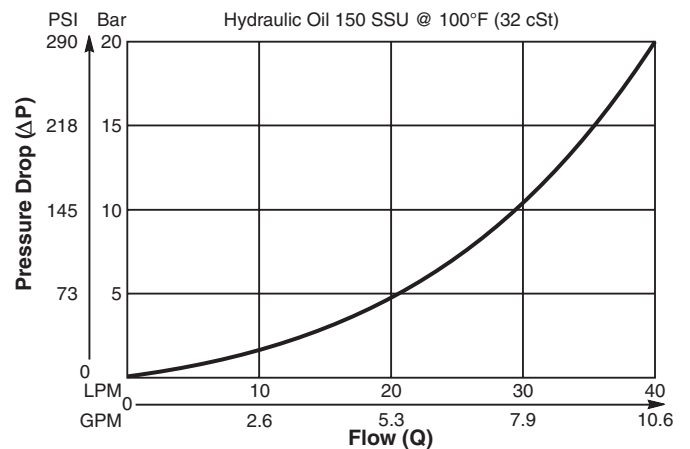

Dimensions Millimeters (Inches)

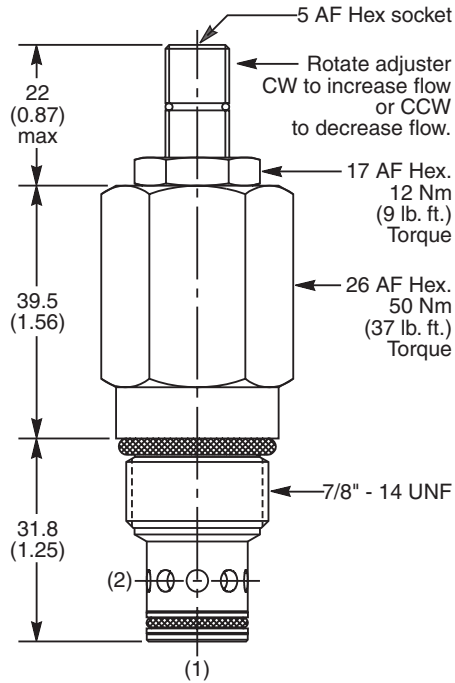

Ordering Information

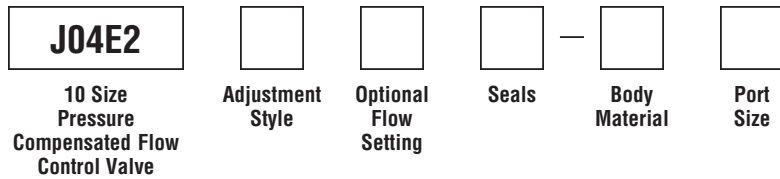

Code	Adjustment Style
Z	Screw Adjust (Std.)
W	Knob Adjust
T	Tamper Resistant Cap (TC1130)

Code	Seals / Kit. No.
N	Nitrile, Buna-N (Std.) / (SK30500N-1)
V	Fluorocarbon / (SK30500V-1)

Code	Body Material
Omit	Steel
A	Aluminum

Code	Port Size	Body Part No.
Omit	Cartridge Only	
4P	1/4" NPTF	(B10-2-*4P)
6P	3/8" NPTF	(B10-2-*6P)
8P	1/2" NPTF	(B10-2-*8P)
6T	SAE-6	(B10-2-*6T)
8T	SAE-8	(B10-2-*8T)
T8T	SAE-8	(B10-2-T8T)†
6B	3/8" BSPG	(B10-2-6B)†

Code	Optional Flow Setting
Omit	Omit for no setting* Specify setting if required (LPM)

* Appropriate mid-range setting for Standard = 20 LPM

* Add "A" for aluminum, omit for steel.
 † Steel body only.

Technical Information

- CV** Check Valves
- SH** Shuttle Valves
- LM** Load/Motor Controls
- FC** Flow Controls
- PC** Pressure Controls
- LE** Logic Elements
- DC** Directional Controls
- MV** Manual Valves
- SV** Solenoid Valves
- PV** Proportional Valves
- CE** Coils & Electronics
- BC** Bodies & Cavities
- TD** Technical Data

General Description

Restrictive Variable Orifice Style, Pressure Compensated Flow Control Valve. For additional information see Technical Tips on pages FC1-FC4.

Features

- Minimal flow change with pressure variation
- Partial reverse flow capability
- Full adjustment from 1-40 LPM (0.3-10.6 GPM)
- Hardened working parts for maximum durability
- Adjustable and tamperproof versions available
- All external parts zinc plated

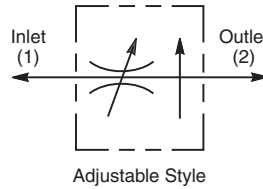
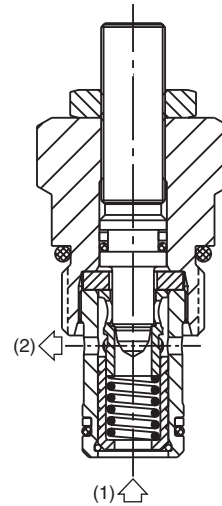

Specifications

Rated Flow	40 LPM (10.6 GPM)
Maximum Inlet Pressure	420 Bar (6000 PSI)
Cartridge Material	All parts steel. All operating parts hardened steel.
Operating Temp. Range/Seals	-40°C to +93.3°C (Nitrile) (-40°F to +200°F) -31.7°C to +121.1°C (Fluorocarbon) (-25°F to +250°F)
Fluid Compatibility/Viscosity	Mineral-based or synthetic with lubricating properties at viscosities of 45 to 2000 SSU (6 to 420 cSt)
Filtration	ISO Code 16/13, SAE Class 4 or better
Approx. Weight	.15 kg (.33 lbs.)
Cavity	C10-2 (See BC Section for more details)
Form Tool	Rougher None Finisher NFT10-2F

Performance Curves (Through cartridge only)

Flow Regulating Performance 2 to 1

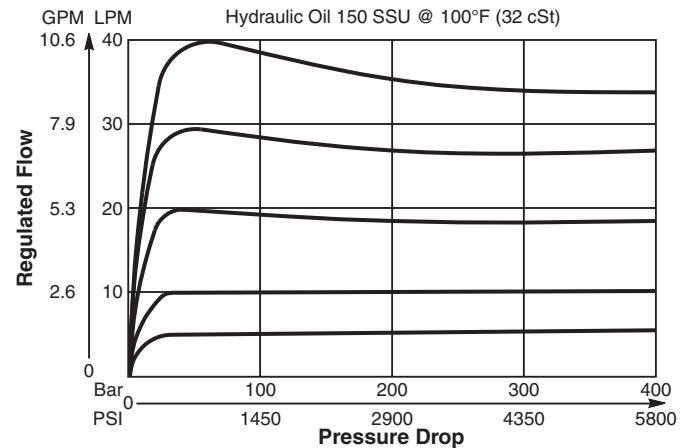

Reverse Flow Pressure Drop vs. Flow 2 to 1

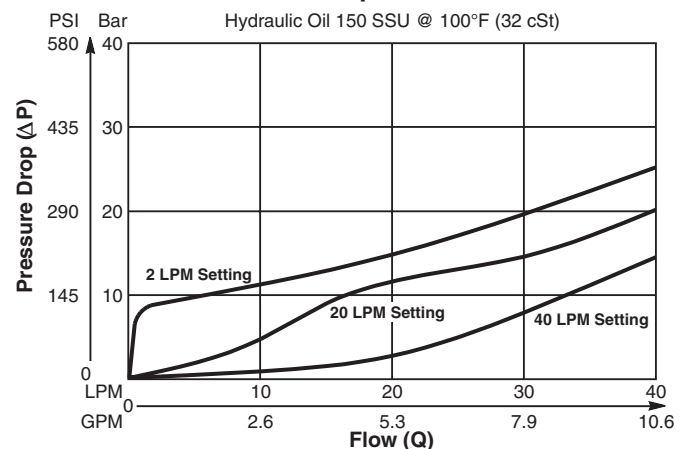

Dimensions Millimeters (Inches)

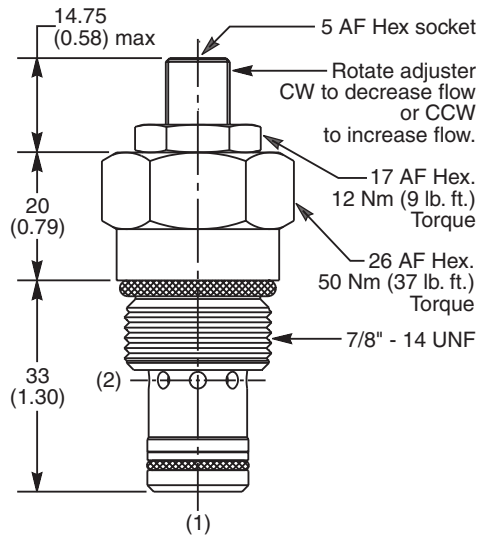

Ordering Information

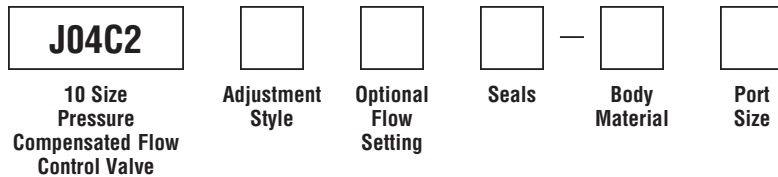

Code	Adjustment Style
Z	Screw Adjust (Std.)
W	Knob Adjust
T	Tamper Resistant Cap (TC1130)

Code	Seals / Kit. No.
N	Nitrile, Buna-N (Std.) / (SK30503N-1)
V	Fluorocarbon / (SK30503V-1)

Code	Body Material
Omit	Steel
A	Aluminum

Code	Port Size	Body Part No.
Omit	Cartridge Only	
4P	1/4" NPTF	(B10-2-*4P)
6P	3/8" NPTF	(B10-2-*6P)
8P	1/2" NPTF	(B10-2-*8P)
6T	SAE-6	(B10-2-*6T)
8T	SAE-8	(B10-2-*8T)
T8T	SAE-8	(B10-2-T8T)†
6B	3/8" BSPG	(B10-2-6B)†

Code	Optional Flow Setting
Omit	Omit for no setting* Specify setting if required (LPM)

* Appropriate mid-range setting for Standard = 20 LPM

* Add "A" for aluminum, omit for steel.
 † Steel body only.

Technical Information

- CV** Check Valves
- SH** Shuttle Valves
- LM** Load/Motor Controls
- FC** Flow Controls
- PC** Pressure Controls
- LE** Logic Elements
- DC** Directional Controls
- MV** Manual Valves
- SV** Solenoid Valves
- PV** Proportional Valves
- CE** Coils & Electronics
- BC** Bodies & Cavities
- TD** Technical Data

General Description

Fully Adjustable, Pressure Compensated Flow Control Valve. For additional information see Technical Tips on pages FC1-FC4.

Features

- Fully adjustable from 0.75 LPM (0.2 GPM) to 20.6 LPM (5.5 GPM)
- Hardened, precision ground parts for durability
- All external parts are finished in yellow zinc dichromate. This enables them to withstand a 200 hour salt spray test.
- Compact size for reduced space requirements

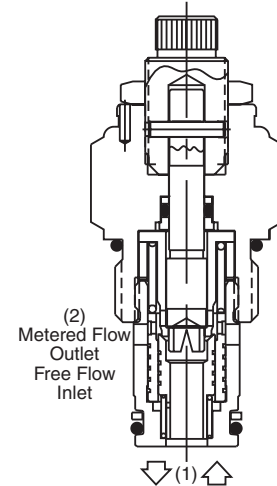
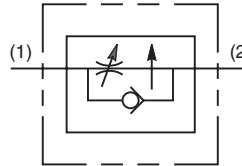
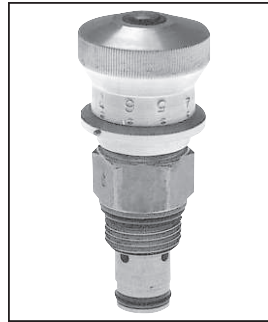

Specifications

Rated Flow	0.75 LPM (0.2 GPM) 20.6 LPM (5.5 GPM)
Maximum Inlet Pressure	210 Bar (3000 PSI)
Cartridge Material	All parts steel. All operating parts hardened steel.
Operating Temp. Range/Seals	-40°C to +93.3°C (Nitrile) (-40°F to +200°F) -31.7°C to +121.1°C (Fluorocarbon) (-25°F to +250°F)
Fluid Compatibility/ Viscosity	Mineral-based or synthetic with lubricating properties at viscosities of 45 to 2000 SSU (6 to 420 cSt)
Filtration	ISO Code 16/13, SAE Class 4 or better
Approx. Weight	.23 kg (0.5 lbs.)
Cavity	C10-2 (See BC Section for more details)
Form Tool	Rougher None Finisher NFT10-2F

Performance Curves

Regulated Flow vs. Pressure Drop
(Through cartridge only)

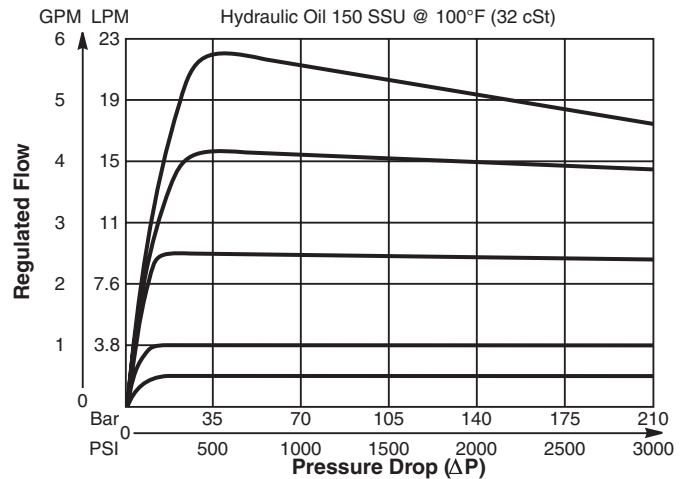

Dimensions Millimeters (Inches)

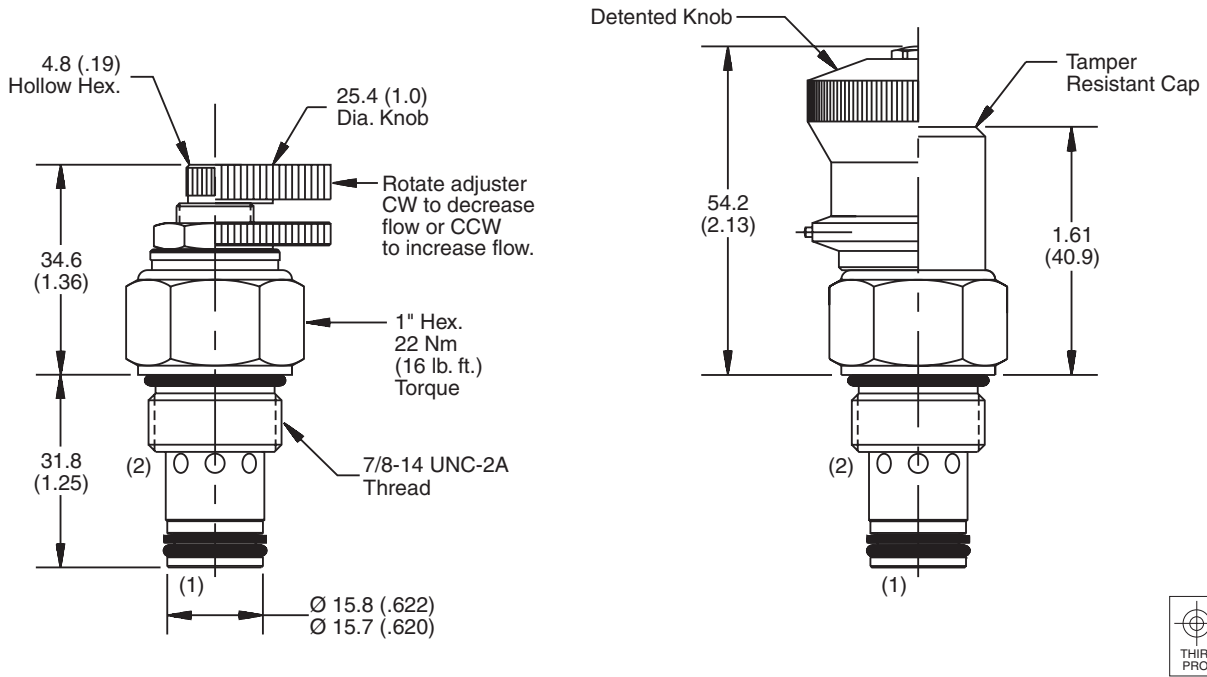

Ordering Information

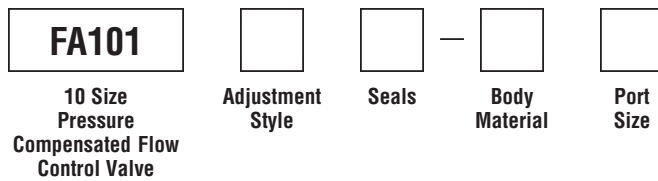

Code	Adjustment Style
D	Detented Knob
K	Knob Adjust (717784-10)
S	Screw Adjust
T	Tamper Resistant Cap (717785)

Code	Seals / Kit. No.
Omit	Nitrile / (SK10-2N)
V	Fluorocarbon / (SK10-2V)

Code	Body Material
Omit	Steel
A	Aluminum

Code	Port Size	Body Part No.
Omit	Cartridge Only	
4P	1/4" NPTF	(B10-2-*4P)
6P	3/8" NPTF	(B10-2-*6P)
8P	1/2" NPTF	(B10-2-*8P)
6T	SAE-6	(B10-2-*6T)
8T	SAE-8	(B10-2-*8T)
T8T	SAE-8	(B10-2-T8T)†
6B	3/8" BSPG	(B10-2-*6B)

* Add "A" for aluminum, omit for steel.
 † Steel body only.

Technical Information

- CV** Check Valves
- SH** Shuttle Valves
- LM** Load/Motor Controls
- FC** Flow Controls
- PC** Pressure Controls
- LE** Logic Elements
- DC** Directional Controls
- MV** Manual Valves
- SV** Solenoid Valves
- PV** Proportional Valves
- CE** Coils & Electronics
- BC** Bodies & Cavities
- TD** Technical Data

General Description

Pressure Compensated Flow Control. For additional information see Technical Tips on pages FC1-FC4.

Features

- Hardened, precision ground parts for durability
- Compact size for reduced space requirements
- Free flow in reverse condition
- All external parts zinc plated

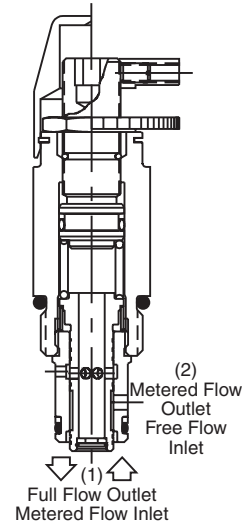
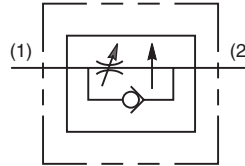
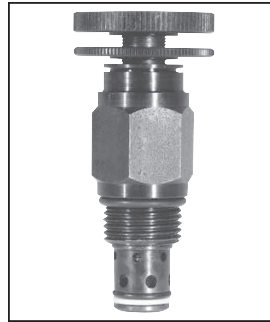

Specifications

Rated Flow	20.6 LPM (5.5 GPM)
Maximum Inlet Pressure	210 Bar (3000 PSI)
Cartridge Material	All parts steel. All operating parts hardened steel.
Operating Temp. Range/Seals	-40°C to +93.3°C (Nitrile) (-40°F to +200°F) -31.7°C to +121.1°C (Fluorocarbon) (-25°F to +250°F)
Fluid Compatibility/ Viscosity	Mineral-based or synthetic with lubricating properties at viscosities of 45 to 2000 SSU (6 to 420 cSt)
Filtration	ISO Code 16/13, SAE Class 4 or better
Approx. Weight	.23 kg (0.5 lbs.)
Cavity	C10-2 (See BC Section for more details)
Form Tool	Rougher None Finisher NFT10-2F

Performance Curves

Regulated Flow vs. Pressure Drop
(Through cartridge only)

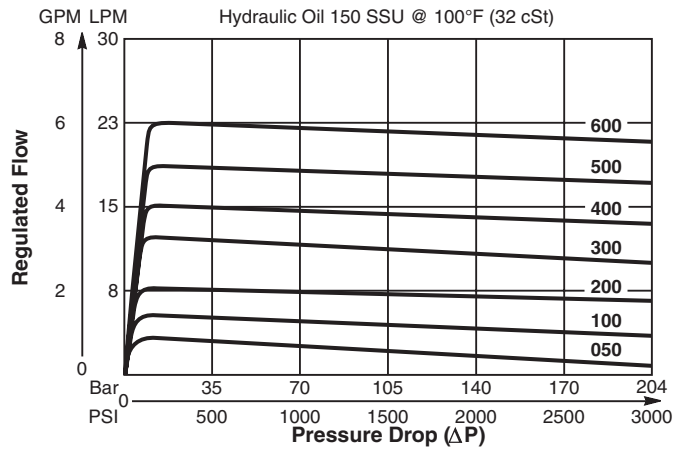

Pressure Drop vs. Flow (Through cartridge only)

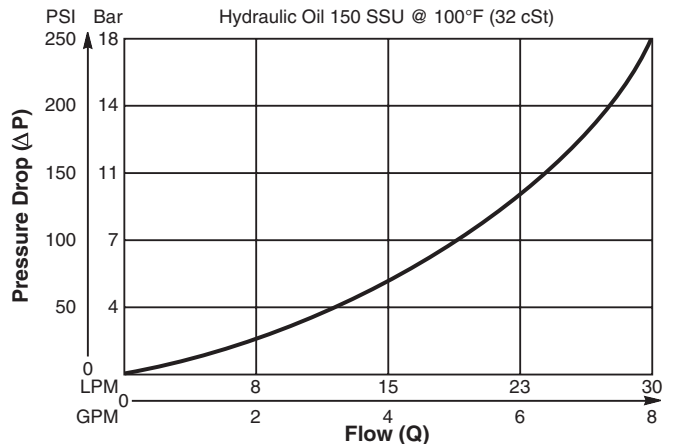

Dimensions Millimeters (Inches)

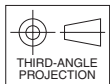
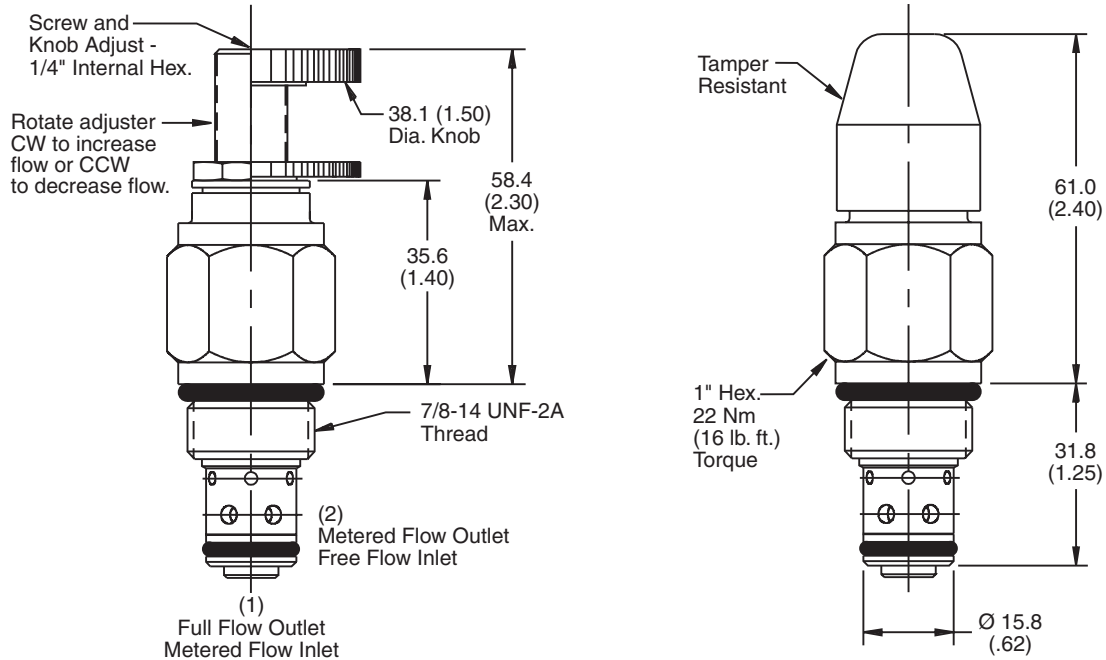

Ordering Information

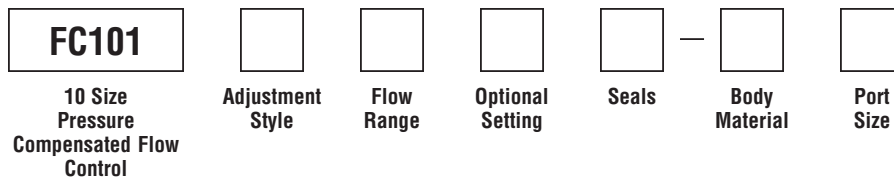

Code	Adjustment Style
K	Knob Adjust (840208K)
S	Screw Adjust
T	Tamper Resistant Cap (717783)

Code	Optional Setting
	Flow setting specified in .38 LPM (.1 GPM) increments other than standard

Code	Body Material
Omit	Steel
A	Aluminum

Code	Flow Range and Standard Setting
050	1.1-3.8 LPM (.30-1.0 GPM) (1.9 LPM (.5 GPM) @ 69 Bar (1000 PSI) ΔP)
100	2.8-8.3 LPM (.75-2.2 GPM) (3.8 LPM (1 GPM) @ 69 Bar (1000 PSI) ΔP)
300	7.5-16.9 LPM (2.0-4.5 GPM) (11.3 LPM (3 GPM) @ 69 Bar (1000 PSI) ΔP)
600	15-30 LPM (4.0-8.0 GPM) (22.5 LPM (6 GPM) @ 69 Bar (1000 PSI) ΔP)

Code	Seals / Kit. No.
Omit	Nitrile / (SK10-2N)
V	Fluorocarbon / (SK10-2V)

Code	Port Size	Body Part No.
Omit	Cartridge Only	
4P	1/4" NPTF	(B10-2-*4P)
6P	3/8" NPTF	(B10-2-*6P)
8P	1/2" NPTF	(B10-2-*8P)
6T	SAE-6	(B10-2-*6T)
8T	SAE-8	(B10-2-*8T)
T8T	SAE-8	(B10-2-T8T)†
6B	3/8" BSPG	(B10-2-6B)†

* Add "A" for aluminum, omit for steel.
 † Steel body only.

Technical Information

- CV** Check Valves
- SH** Shuttle Valves
- LM** Load/Motor Controls
- FC** Flow Controls
- PC** Pressure Controls
- LE** Logic Elements
- DC** Directional Controls
- MV** Manual Valves
- SV** Solenoid Valves
- PV** Proportional Valves
- CE** Coils & Electronics
- BC** Bodies & Cavities
- TD** Technical Data

General Description

Needle Type, Pressure Compensated Flow Regulator Valve. For additional information see Technical Tips on pages FC1-FC4.

Features

- Good adjustment from 1-15 LPM (0.3-4 GPM)
- Used for systems requiring priority flow such as steering systems
- Hardened working parts for maximum durability
- Reverse flow function 3 to 1
- Adjustable and tamperproof versions available
- All external parts zinc plated

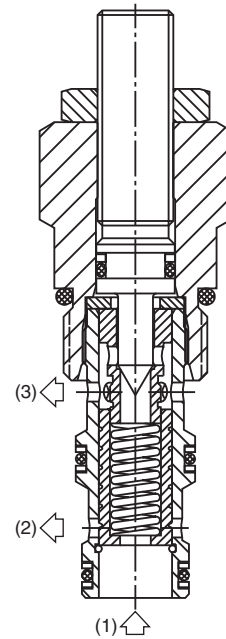
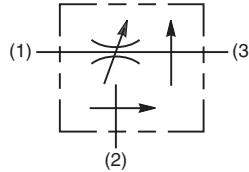

Specifications

Rated Flow	15 LPM (4 GPM)
Maximum Inlet Pressure	420 Bar (6000 PSI)
Cartridge Material	All parts steel. All operating parts hardened steel.
Operating Temp. Range/Seals	-40°C to +93.3°C (Nitrile) (-40°F to +200°F) -31.7°C to +121.1°C (Fluorocarbon) (-25°F to +250°F)
Fluid Compatibility/ Viscosity	Mineral-based or synthetic with lubricating properties at viscosities of 45 to 2000 SSU (6 to 420 cSt)
Filtration	ISO Code 16/13, SAE Class 4 or better
Approx. Weight	.08 kg (.18 lbs.)
Cavity	C08-3 (See BC Section for more details)
Form Tool	Rougher NFT08-3R Finisher NFT08-3F

Performance Curves (Through cartridge only)

Flow Regulating Performance

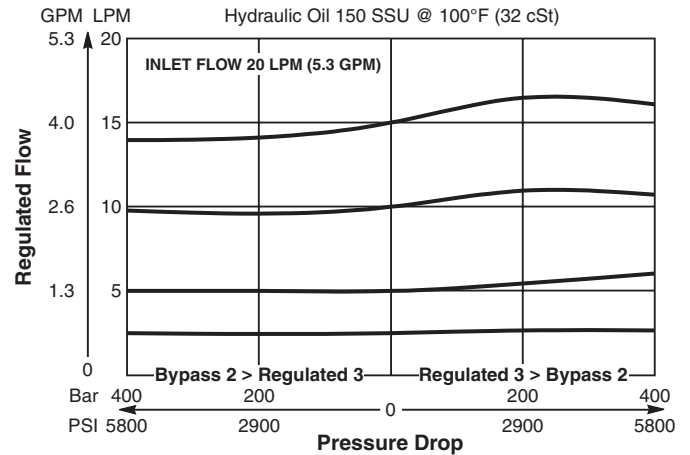

Application

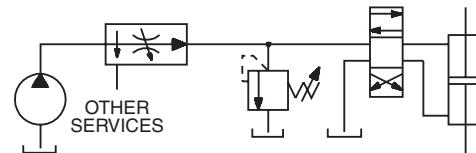

Priority flow on steering circuit

Dimensions Millimeters (Inches)

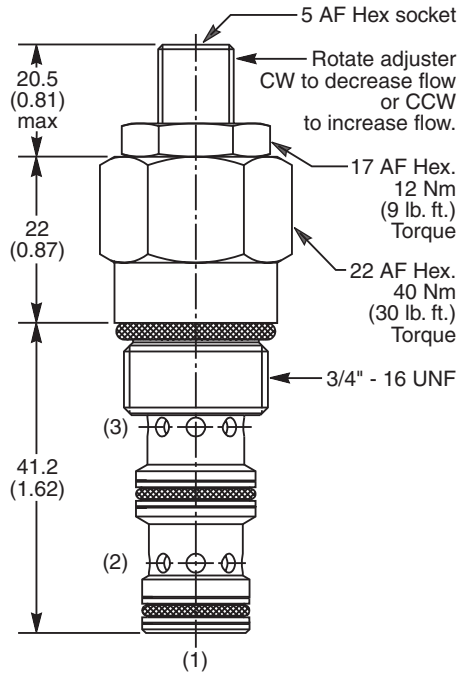

Ordering Information

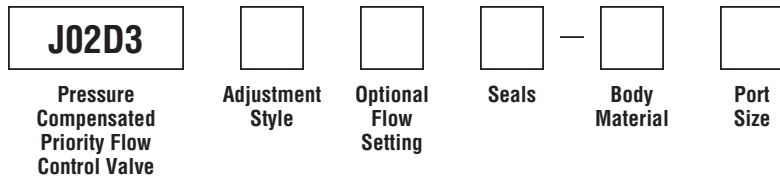

Code	Adjustment Style
Z	Screw Adjust (Std.)
W	Knob Adjust
T	Tamper Resistant Cap (TC1130)

Code	Seals / Kit. No.
N	Nitrile, Buna-N (Std.) / (SK30501N-1)
V	Fluorocarbon / (SK30501V-1)

Code	Body Material
Omit	Steel
A	Aluminum

Code	Port Size	Body Part No.
Omit	Cartridge Only	
4P	1/4" NPTF	(B08-3-*4P)
4T	SAE-4	(B08-3-*4T)
6T	SAE-6	(B08-3-*6T)
6B	3/8" BSPG	(B08-3-*6B)

* Add "A" for aluminum, omit for steel.

Code	Optional Flow Setting
Omit	Omit for no setting* Specify setting if required (LPM)

* Appropriate mid-range setting for Standard = 7 LPM

- CV**
Check Valves
- SH**
Shuttle Valves
- LM**
Load/Motor Controls
- FC**
Flow Controls
- PC**
Pressure Controls
- LE**
Logic Elements
- DC**
Directional Controls
- MV**
Manual Valves
- SV**
Solenoid Valves
- PV**
Proportional Valves
- CE**
Coils & Electronics
- BC**
Bodies & Cavities
- TD**
Technical Data

Technical Information

- CV** Check Valves
- SH** Shuttle Valves
- LM** Load/Motor Controls
- FC** Flow Controls
- PC** Pressure Controls
- LE** Logic Elements
- DC** Directional Controls
- MV** Manual Valves
- SV** Solenoid Valves
- PV** Proportional Valves
- CE** Coils & Electronics
- BC** Bodies & Cavities
- TD** Technical Data

General Description

Pressure Compensated Priority Flow Regulator Valve. For additional information see Technical Tips on pages FC1-FC4.

Caution: If the priority line is blocked so that no flow can pass through the control orifice; the compensator spool will shift, blocking the bypass port and allowing inlet pressure to go to full system relief pressure. The FP101 cartridge does not provide a pressure relieving function.

Specifications

Maximum Priority Flow	Fixed 30.0 LPM (8 GPM) Adjusted 33.8 LPM (9 GPM)
Maximum Inlet Flow	56.3 LPM (15 GPM)
Minimum Inlet Flow	See Valve Performance Curves
Maximum Inlet Pressure	245 Bar (3500 PSI)
Minimum Inlet Pressure	See Valve Performance Curves
Accuracy (Fixed)	±20%
Adjustment Range (Adj. Version)	±20% Nominal
Cartridge Material	All parts steel. All operating parts hardened steel.
Operating Temp. Range/Seals	-40°C to +93.3°C (Nitrile) (-40°F to +200°F) -31.7°C to +121.1°C (Fluorocarbon) (-25°F to +250°F)
Fluid Compatibility/Viscosity	Mineral-based or synthetic with lubricating properties at viscosities of 45 to 2000 SSU (6 to 420 cSt)
Filtration	ISO Code 16/13, SAE Class 4 or better
Approx. Weight	.23 kg (0.5 lbs.)
Cavity	No. C10-3 (See BC Section for more details)
Form Tool	Regulator NFT10-3R Finisher NFT10-3F

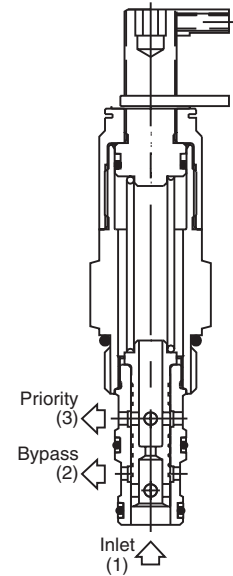
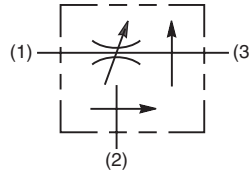

Features

- Hardened, precision ground parts for durability
- Cartridge design
- Acts as a fixed orifice in reverse flow condition (Priority line only)
- All external parts zinc plated

Dimensions Millimeters (Inches)

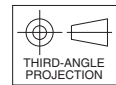
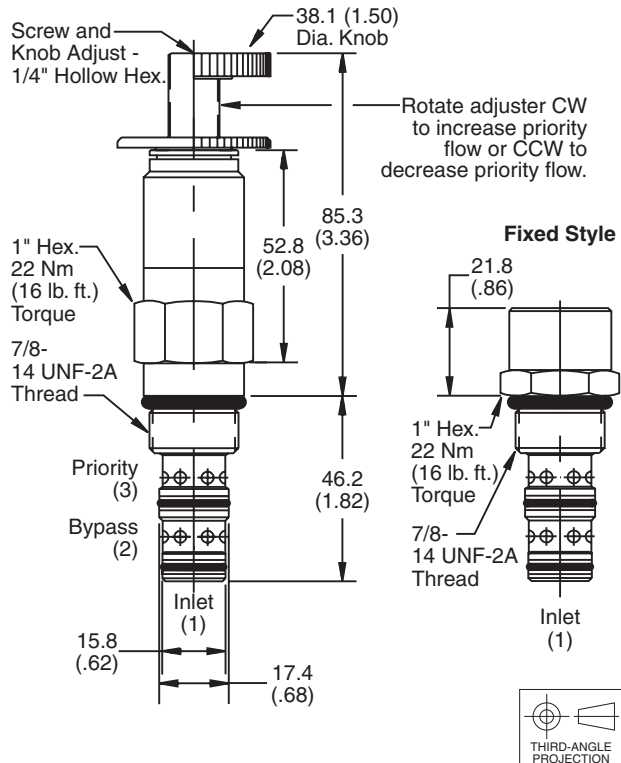

Performance Curves (Through cartridge only)

Regulated Flow vs. Load Pressure

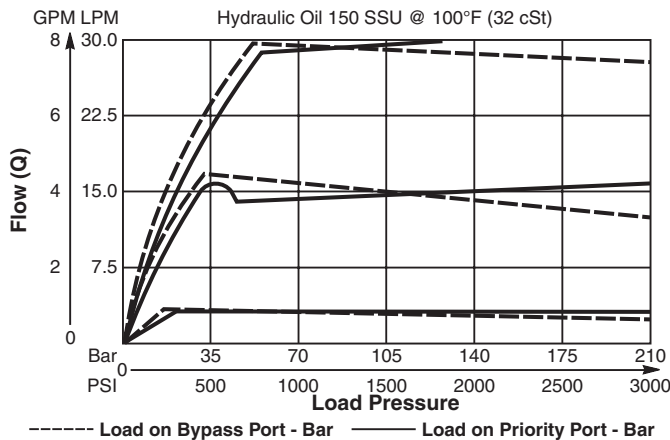

Pressure vs. Priority Flow

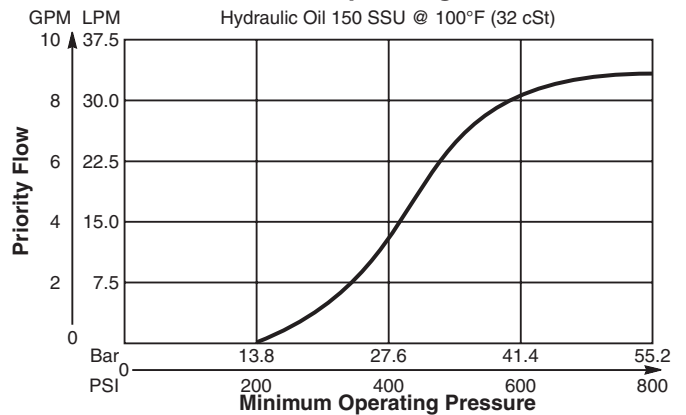

Minimum Inlet Flow

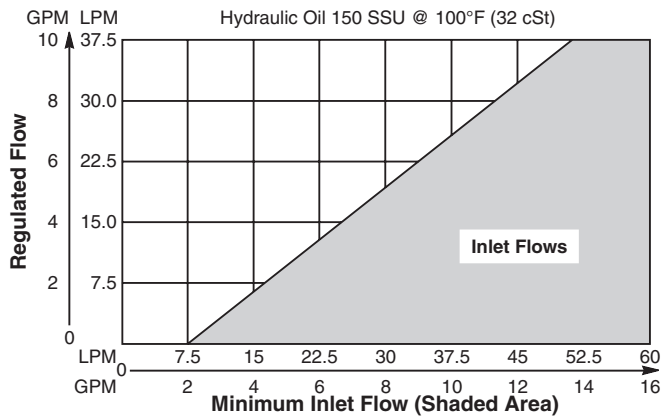

Inlet Flow vs. Regulated Flow

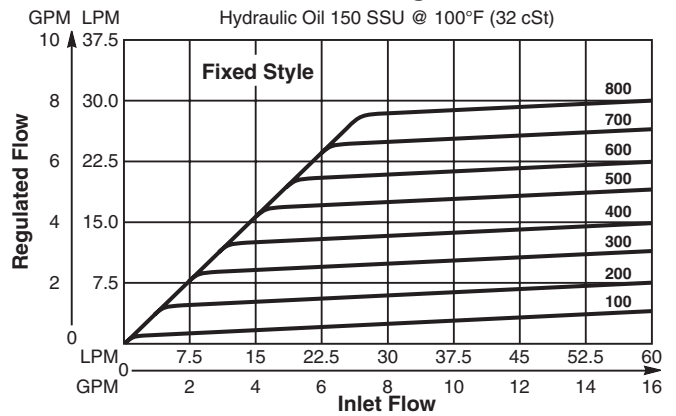

Ordering Information

FP101 —

10 Size Pressure Compensated Flow Regulator **Adjustment Style** **Flow Setting/Range** **Seals** **Body Material** **Port Size**

Code	Adjustment Style
F	Fixed Style present at factory
K	Knob Adjust
S	Screw Adjust

Code	Fixed Style Flow	Code	Knob/Screw Style Flow Range
100	3.8 LPM (1 GPM)	085	2.6-3.8 LPM (0.7-1.0 GPM)
200	7.5 LPM (2 GPM)	110	3.0-5.3 LPM (0.8-1.4 GPM)
300	11.3 LPM (3 GPM)	155	4.5-7.1 LPM (1.2-1.9 GPM)
400	15 LPM (4 GPM)	220	6.4-10.1 LPM (1.7-2.7 GPM)
500	18.8 LPM (5 GPM)	295	8.6-13.5 LPM (2.3-3.6 GPM)
600	22.5 LPM (6 GPM)	405	11.6-18.8 LPM (3.1-5.0 GPM)
700	26.3 LPM (7 GPM)	575	16.9-26.3 LPM (4.5-7.0 GPM)
800	30 LPM (8 GPM)	780	23.6-34.9 LPM (6.3-9.3 GPM)

Code	Seals / Kit. No.
Omit	Nitrile / (SK10-3N)
V	Fluorocarbon / (SK10-3V)

Code	Body Material
Omit	Steel
A	Aluminum

Code	Port Size	Body Part No.
Omit	Cartridge Only	
4P	1/4" NPTF	(B10-3-*4P)
6P	3/8" NPTF	(B10-3-*6P)
8P	1/2" NPTF	(B10-3-*8P)
6T	SAE-6	(B10-3-*6T)
8T	SAE-8	(B10-3-*8T)
6B	3/8" BSPG	(B10-3-6B)†
8B	1/2" BSPG	(B10-3-*8B)

* Add "A" for aluminum, omit for steel.
 † Steel body only.

Technical Information

- CV** Check Valves
- SH** Shuttle Valves
- LM** Load/Motor Controls
- FC** Flow Controls
- PC** Pressure Controls
- LE** Logic Elements
- DC** Directional Controls
- MV** Manual Valves
- SV** Solenoid Valves
- PV** Proportional Valves
- CE** Coils & Electronics
- BC** Bodies & Cavities
- TD** Technical Data

General Description

Priority Type, Pressure Compensated Flow Regulator Valve. For additional information see Technical Tips on pages FC1-FC4.

Features

- High flow capacity
- Good adjustment from 2-45 LPM (0.5-12 GPM)
- Used for systems requiring priority flow such as steering systems
- Hardened working parts for maximum durability
- Reverse flow function 3 to 1
- Adjustable and tamperproof versions available
- All external parts zinc plated

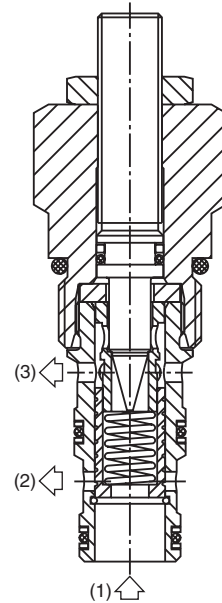
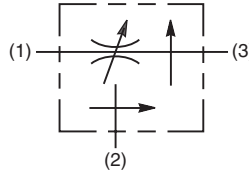
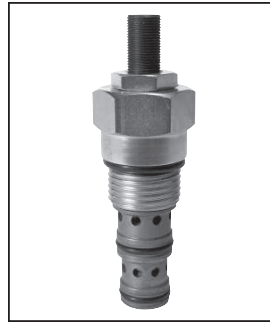

Specifications

Rated Flow	45 LPM (12 GPM)
Maximum Inlet Pressure	420 Bar (6000 PSI)
Cartridge Material	All parts steel. All operating parts hardened steel.
Operating Temp. Range/Seals	-40°C to +93.3°C (Nitrile) (-40°F to +200°F) -31.7°C to +121.1°C (Fluorocarbon) (-25°F to +250°F)
Fluid Compatibility/ Viscosity	Mineral-based or synthetic with lubricating properties at viscosities of 45 to 2000 SSU (6 to 420 cSt)
Filtration	ISO Code 16/13, SAE Class 4 or better
Approx. Weight	.18 kg (.40 lbs.)
Cavity	C10-3 (See BC Section for more details)
Form Tool	Rougher NFT10-3R Finisher NFT10-3F

Performance Curves (Through cartridge only)

Flow Regulating Performance

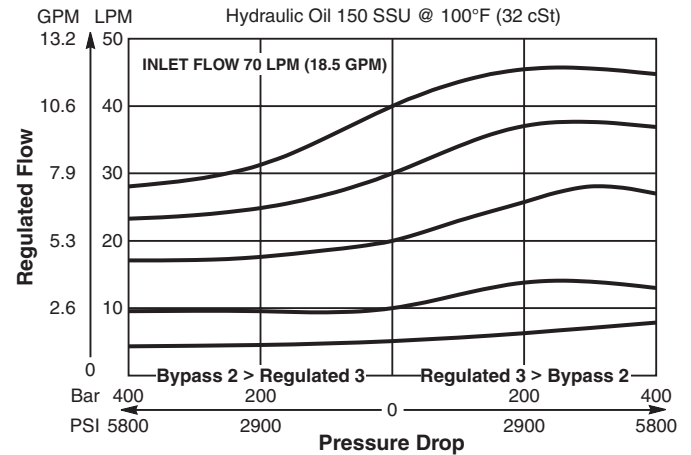

Application

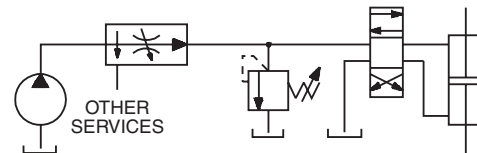

Priority flow on steering circuit

Dimensions Millimeters (Inches)

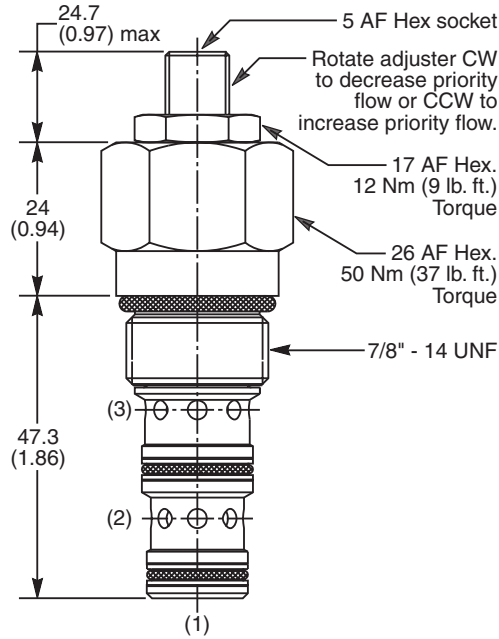

Ordering Information

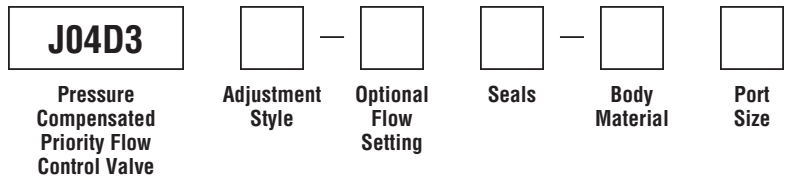

Code	Adjustment Style
Z	Screw Adjust (Std.)
W	Knob Adjust (ASV014975)
T	Tamper Resistant Cap (TC1130)

Code	Seals / Kit. No.
N	Nitrile, Buna-N (Std.) / (SK30505N-1)
V	Fluorocarbon / (SK30505V-1)

Code	Body Material
Omit	Steel
A	Aluminum

Code	Port Size	Body Part No.
Omit	Cartridge Only	
4P	1/4" NPTF	(B10-3-*4P)
6P	3/8" NPTF	(B10-3-*6P)
8P	1/2" NPTF	(B10-3-*8P)
6T	SAE-6	(B10-3-*6T)
8T	SAE-8	(B10-3-*8T)
6B	3/8" BSPG	(B10-3-6B)†
8B	1/2" BSPG	(B10-3-*8B)

Code	Optional Flow Setting
Omit	Omit for no setting* Specify setting if required (LPM)

* Appropriate mid-range setting for Standard = 20 LPM

* Add "A" for aluminum, omit for steel.
 † Steel body only.

CV
Check Valves

SH
Shuttle Valves

LM
Load/Motor Controls

FC
Flow Controls

PC
Pressure Controls

LE
Logic Elements

DC
Directional Controls

MV
Manual Valves

SV
Solenoid Valves

PV
Proportional Valves

CE
Coils & Electronics

BC
Bodies & Cavities

TD
Technical Data

Technical Information

- CV** Check Valves
- SH** Shuttle Valves
- LM** Load/Motor Controls
- FC** Flow Controls
- PC** Pressure Controls
- LE** Logic Elements
- DC** Directional Controls
- MV** Manual Valves
- SV** Solenoid Valves
- PV** Proportional Valves
- CE** Coils & Electronics
- BC** Bodies & Cavities
- TD** Technical Data

General Description

Priority Style, Pressure Compensated Flow Regulator Valve With Bypass. For additional information see Technical Tips on pages FC1-FC4.

Features

- Free reverse flow function
- High flow capacity
- Used for systems requiring priority flow such as steering systems
- Hardened working parts for maximum durability
- Adjustable and tamperproof versions available
- All external parts zinc plated

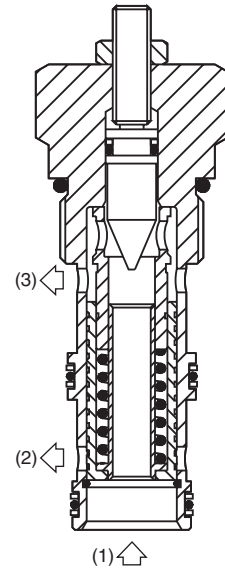
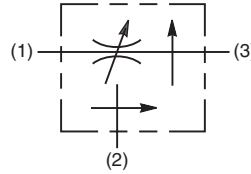

Specifications

Rated Flow	90 LPM (24 GPM)
Maximum Regulated Flow	38 LPM (10 GPM)
Maximum Inlet Pressure	350 Bar (5000 PSI)
Cartridge Material	All parts steel. All operating parts hardened steel.
Operating Temp. Range/Seals	-40°C to +93.3°C (Nitrile) (-40°F to +200°F) -31.7°C to +121.1°C (Fluorocarbon) (-25°F to +250°F)
Fluid Compatibility/ Viscosity	Mineral-based or synthetic with lubricating properties at viscosities of 45 to 2000 SSU (6 to 420 cSt)
Filtration	ISO Code 16/13, SAE Class 4 or better
Approx. Weight	.45 kg (1.00 lbs.)
Cavity	3A (See BC Section for more details)
Form Tool	Rougher Finisher

Performance Curve (Through cartridge only)

Flow Regulating Performance

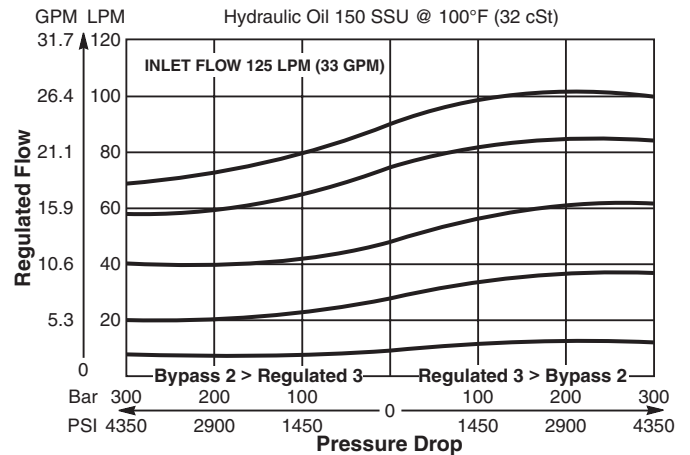

Application

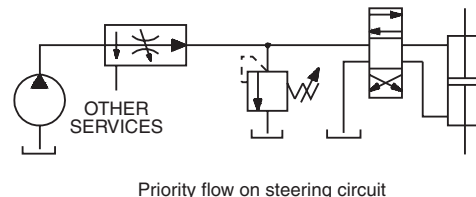

Dimensions Millimeters (Inches)

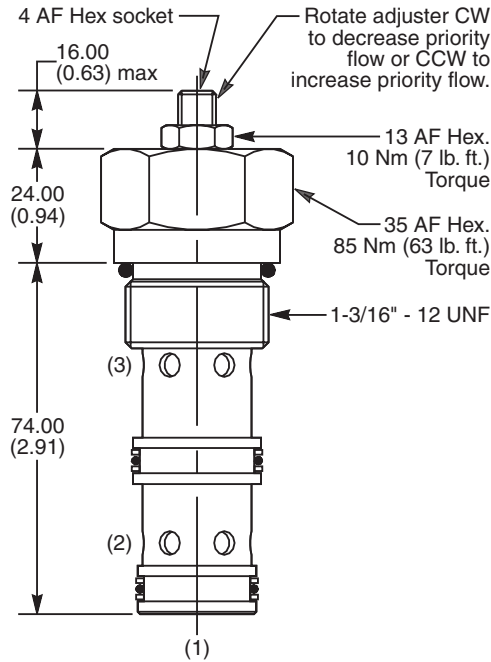

Ordering Information

J1A125	<input type="checkbox"/>	<input type="checkbox"/>	<input type="checkbox"/>
Pressure Compensated Priority Flow Control Valve	Adjustment Style	Optional Regulated Flow Setting	Seals

Code	Adjustment Style
Z	Screw Adjust (Std.)
W	Knob Adjust
T	Tamper Resistant Cap (TC1124)

Code	Seals / Kit. No.
N	Nitrile, Buna-N (Std.) / (SK30011N-1)
V	Fluorocarbon / (SK30011V-1)

Code	Optional Regulated Flow Setting
Omit	Omit for no setting (Std.)* Specify setting if required (LPM)

* Setting for standard: J1A125
 Inlet: 45 LPM (12 GPM)
 Regulated: 25 LPM (6.5 GPM)

Order Bodies Separately

LB10	<input type="checkbox"/>	<input type="checkbox"/>
Line Body	Porting	Body Material

Code	Porting
007	3/4" BSP
066	1" SAE

Code	Body Material
A	Aluminum
S	Steel

- CV**
Check Valves
- SH**
Shuttle Valves
- LM**
Load/Motor Controls
- FC**
Flow Controls
- PC**
Pressure Controls
- LE**
Logic Elements
- DC**
Directional Controls
- MV**
Manual Valves
- SV**
Solenoid Valves
- PV**
Proportional Valves
- CE**
Coils & Electronics
- BC**
Bodies & Cavities
- TD**
Technical Data

Technical Information

- CV Check Valves
- SH Shuttle Valves
- LM Load/Motor Controls
- FC Flow Controls
- PC Pressure Controls
- LE Logic Elements
- DC Directional Controls
- MV Manual Valves
- SV Solenoid Valves
- PV Proportional Valves
- CE Coils & Electronics
- BC Bodies & Cavities
- TD Technical Data

General Description

Restrictive Type Pressure Compensator. This valve is designed to be used in conjunction with an external orifice, fixed or variable, to provide a constant flow regardless of changes in load or pressure. For additional information see Technical Tips on pages FC1-FC4.

Features

- Hardened, precision ground parts for durability
- Stable and quiet response
- Contamination tolerant
- Standard valve bodies and common cavities
- Seal variations and other options available
- All external parts zinc plated

Performance Curve

Control ΔP (Through cartridge only)

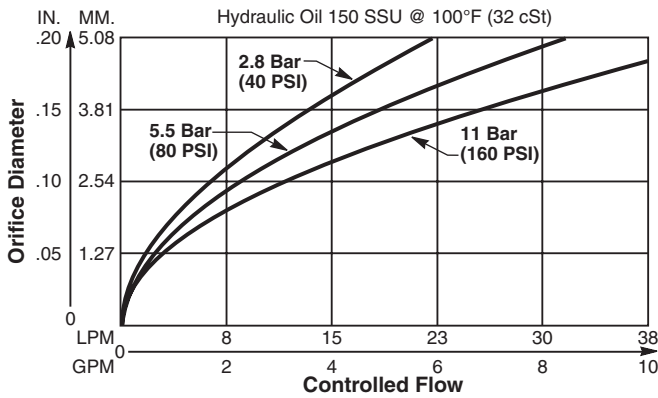

Specifications

Rated Flow	38 LPM (10 GPM)
Maximum Inlet Pressure	245 Bar (3500 PSI)
Accuracy (Fixed)	±10% Spring rating to 210 Bar (3000 PSI)
Adjustment Range	None
Cartridge Material	All parts steel. All operating parts hardened steel.
Operating Temp. Range/Seals	-40°C to +93.3°C (Nitrile) (-40°F to +200°F) -31.7°C to +121.1°C (Fluorocarbon) (-25°F to +250°F)
Fluid Compatibility/Viscosity	Mineral-based or synthetic with lubricating properties at viscosities of 45 to 2000 SSU (6 to 420 cSt)
Filtration	ISO Code 16/13, SAE Class 4 or better
Approx. Weight	.14 kg (0.3 lbs.)
Cavity	C10-3 (See BC Section for more details)
Form Tool	Rougher NFT10-3R Finisher NFT10-3F

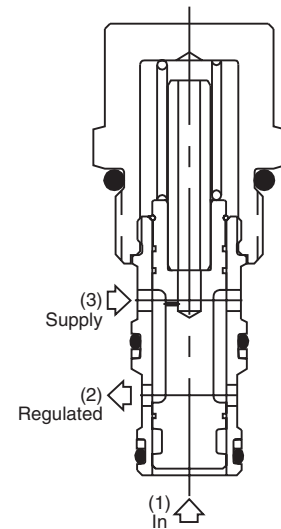
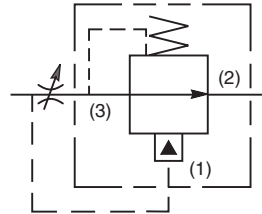
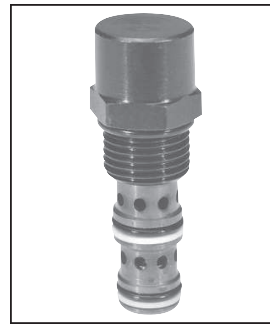

Dimensions Millimeters (Inches)

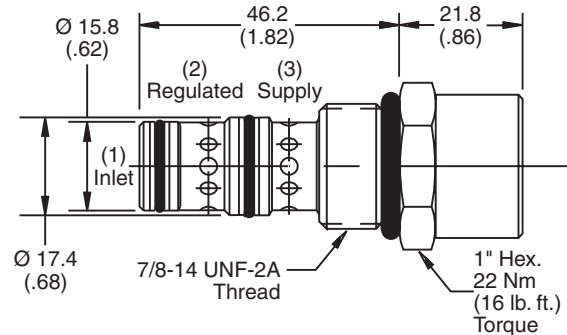

Ordering Information

FCR101F [] [] [] [] []
 10 Size Pressure Compensator Valve (Fixed Style) Pressure Differential Seals Body Material Port Size

Code	Press. Differential
Omit	11 Bar (160 PSI)
04	2.8 Bar (40 PSI)
08	5.5 Bar (80 PSI)

Code	Body Material
Omit	Steel
A	Aluminum

Code	Seals / Kit No.
Omit	Nitrile / (SK10-3N)
V	Fluorocarbon / (SK10-3V)

Code	Port Size	Body Part No.
Omit	Cartridge Only	
4P	1/4" NPTF	(B10-3-*4P)
6P	3/8" NPTF	(B10-3-*6P)
8P	1/2" NPTF	(B10-3-*8P)
6T	SAE-6	(B10-3-*6T)
8T	SAE-8	(B10-3-*8T)
6B	3/8" BSPG	(B10-3-6B)†
8B	1/2" BSPG	(B10-3-*8B)

* Add "A" for aluminum, omit for steel.
 † Steel body only.



General Description

Restrictive Type Pressure Compensator. This valve is designed to be used in conjunction with an external orifice, fixed or variable, to provide a constant flow regardless of changes in load or pressure. For additional information see Technical Tips on pages FC1-FC4.

Features

- Hardened, precision ground parts for durability
- Stable and quiet response
- Contamination tolerant
- Standard valve bodies and common cavities
- Seal variations and other options available
- All external parts zinc plated

Performance Curve

Control ΔP (Through cartridge only)

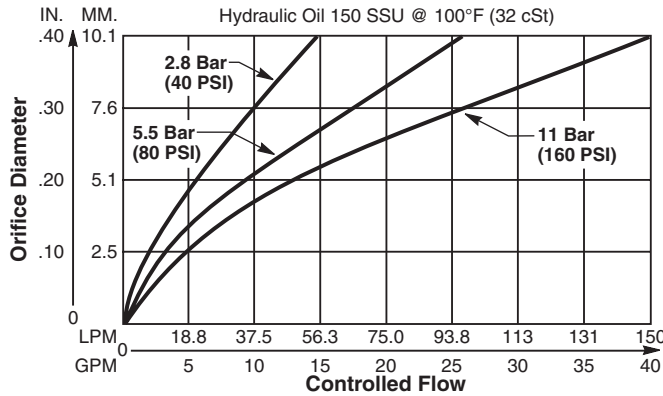

Specifications

Rated Flow	150 LPM (40 GPM)
Maximum Inlet Pressure	245 Bar (3500 PSI)
Accuracy (Fixed)	±10% Spring rating to 210 Bar (3000 PSI)
Adjustment Range	None
Cartridge Material	All parts steel. All operating parts hardened steel.
Operating Temp. Range/Seals	-40°C to +93.3°C (Nitrile) (-40°F to +200°F) -31.7°C to +121.1°C (Fluorocarbon) (-25°F to +250°F)
Fluid Compatibility/Viscosity	Mineral-based or synthetic with lubricating properties at viscosities of 45 to 2000 SSU (6 to 420 cSt)
Filtration	ISO Code 16/13, SAE Class 4 or better
Approx. Weight	.34 kg (.75 lbs.)
Cavity	C16-3 (See BC Section for more details)
Form Tool	Rougher NFT16-3R Finisher NFT16-3F

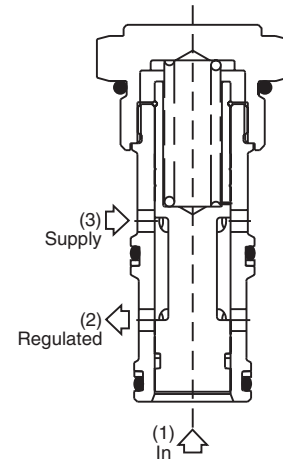
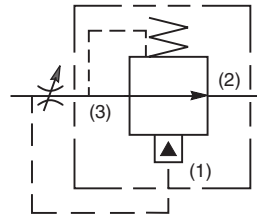
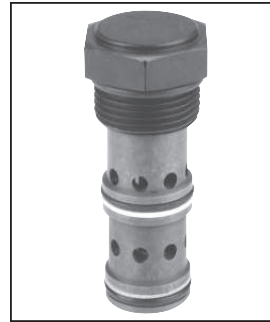

Dimensions Millimeters (Inches)

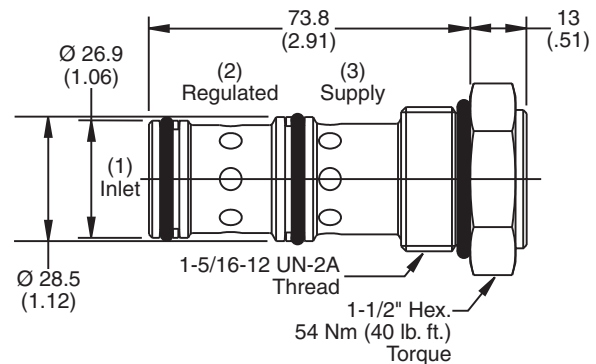

Ordering Information

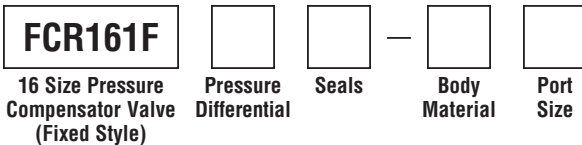

Code	Press. Differential
Omit	11 Bar (160 PSI)
04	2.8 Bar (40 PSI)

Code	Body Material
Omit	Steel
A	Aluminum

Code	Seals / Kit No.
Omit	Nitrile / (SK16-3)
V	Fluorocarbon / (SK16-3V)

Code	Port Size	Body Part No.
Omit	Cartridge Only	
12T	SAE-12	(B16-3-*12T)
16T	SAE-16	(B16-3-*16T)

* Add "A" for aluminum, omit for steel.

- CV** Check Valves
- SH** Shuttle Valves
- LM** Load/Motor Controls
- FC** Flow Controls
- PC** Pressure Controls
- LE** Logic Elements
- DC** Directional Controls
- MV** Manual Valves
- SV** Solenoid Valves
- PV** Proportional Valves
- CE** Coils & Electronics
- BC** Bodies & Cavities
- TD** Technical Data

- CV** Check Valves
- SH** Shuttle Valves
- LM** Load/Motor Controls
- FC** Flow Controls
- PC** Pressure Controls
- LE** Logic Elements
- DC** Directional Controls
- MV** Manual Valves
- SV** Solenoid Valves
- PV** Proportional Valves
- CE** Coils & Electronics
- BC** Bodies & Cavities
- TD** Technical Data

General Description

Priority Type Pressure Compensator. This valve is designed to be used in conjunction with an external orifice (fixed or variable) to provide a constant flow to the priority port. Excess flow is bypassed through port 2. For additional information see Technical Tips on pages FC1-FC4.

Features

- Hardened, precision ground parts for durability
- Stable and quiet response
- Contamination tolerant
- Standard valve bodies and common cavities
- All external parts zinc plated

Performance Curve

Contol ΔP (Through cartridge only)

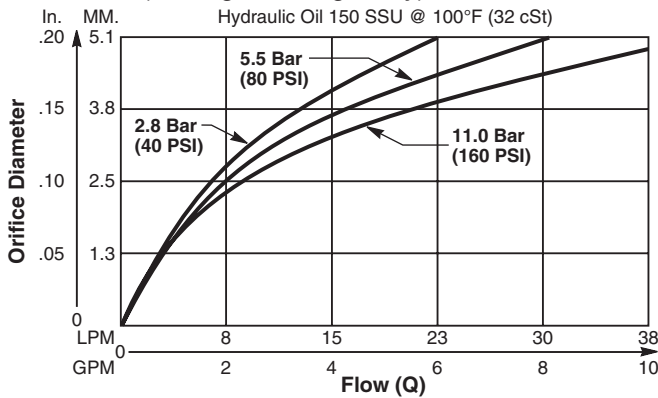

Specifications

Rated Flow	Inlet 56 LPM (15 GPM) Flow Setting 38 LPM (10 GPM)
Maximum Inlet Pressure	245 Bar (3500 PSI)
Accuracy (Fixed)	±10% Spring rating to 210 Bar (3000 PSI)
Adjustment Range	None
Cartridge Material	All parts steel. All operating parts hardened steel.
Operating Temp. Range/Seals	-40°C to +93.3°C (Nitrile) (-40°F to +200°F) -31.7°C to +121.1°C (Fluorocarbon) (-25°F to +250°F)
Fluid Compatibility/Viscosity	Mineral-based or synthetic with lubricating properties at viscosities of 45 to 2000 SSU (6 to 420 cSt)
Filtration	ISO Code 16/13, SAE Class 4 or better
Approx. Weight	.14 kg (0.3 lbs.)
Cavity	C10-4 (See BC Section for more details)
Form Tool	Rougher NFT10-4R Finisher NFT10-4F

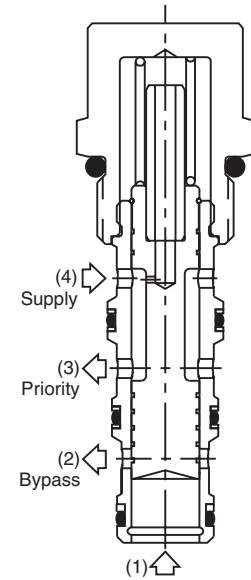
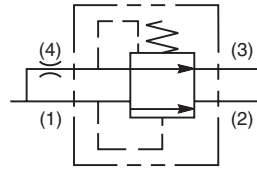

Dimensions

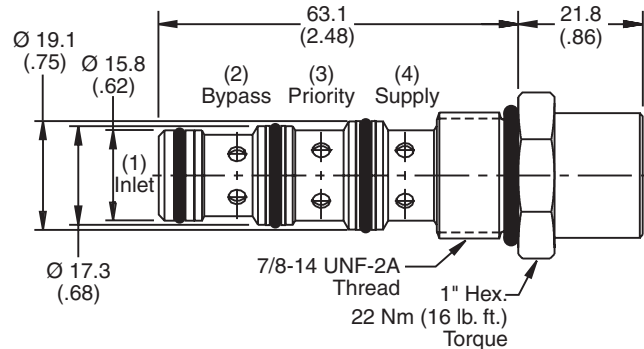

Ordering Information

FCP101F

10 Size Pressure Compensator Valve (Fixed Style) **Pressure Differential** **Seals** **Body Material** **Port Size**

Code	Press. Differential
Omit	11 Bar (160 PSI)
04	2.8 Bar (40 PSI)
08	5.5 Bar (80 PSI)

Code	Body Material
Omit	Steel
A	Aluminum

Code	Seals / Kit No.
Omit	Nitrile / (SK10-4N)
V	Fluorocarbon / (SK10-4V)

Code	Port Size	Body Part No.
Omit	Cartridge Only	
6P	3/8" NPTF	(B10-4-*6P)
6T	SAE-6	(B10-4-*6T)
8T	SAE-8	(B10-4-*8T)
6B	3/8" BSPG	(B10-4-6B)†

* Add "A" for aluminum, omit for steel.
 † Steel body only.

Notes

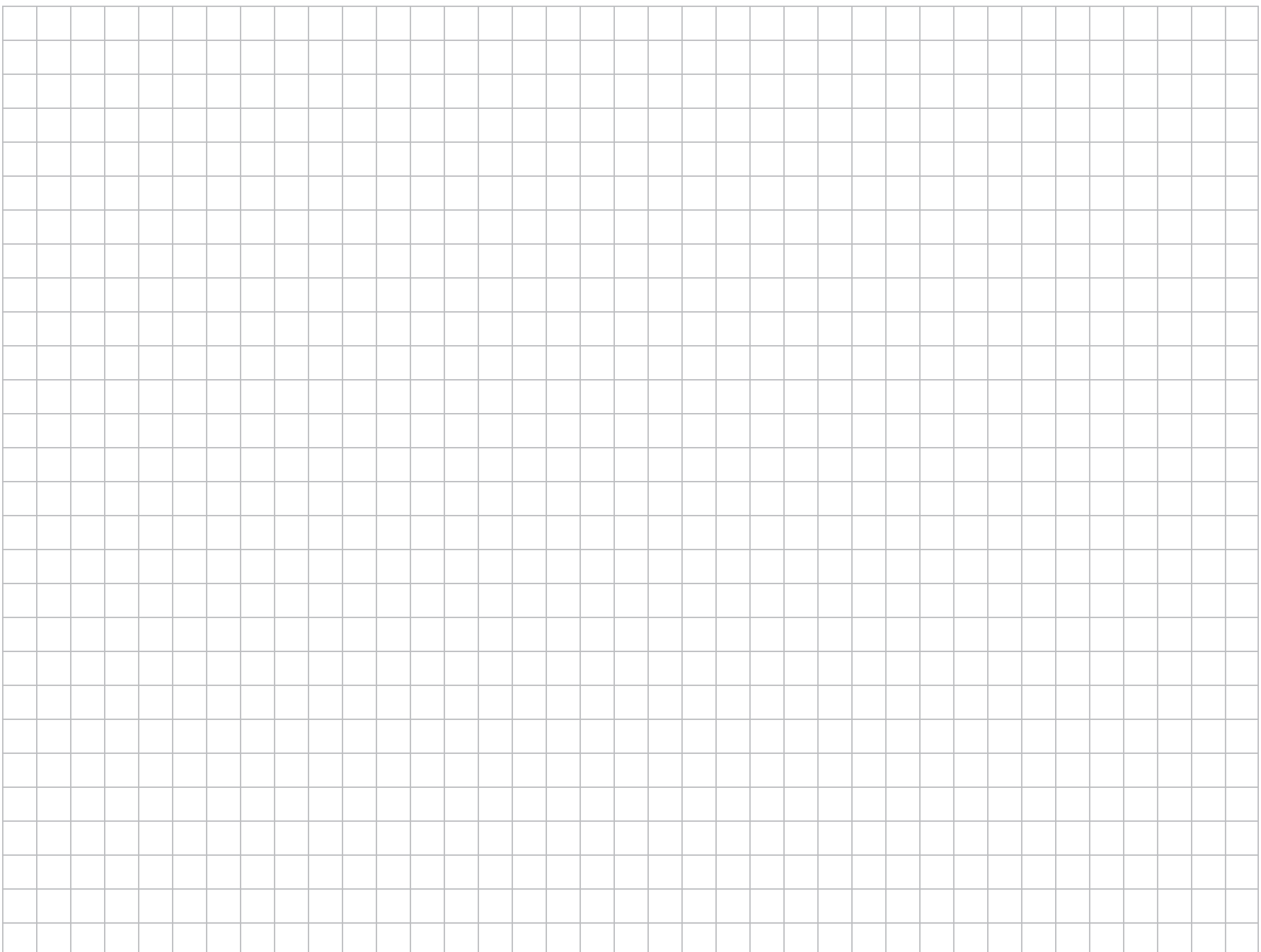

CV
Check Valves

SH
Shuttle Valves

LM
Load/Motor Controls

FC
Flow Controls

PC
Pressure Controls

LE
Logic Elements

DC
Directional Controls

MV
Manual Valves

SV
Solenoid Valves

PV
Proportional Valves

CE
Coils & Electronics

BC
Bodies & Cavities

TD
Technical Data

Technical Information

- CV** Check Valves
- SH** Shuttle Valves
- LM** Load/Motor Controls
- FC** Flow Controls
- PC** Pressure Controls
- LE** Logic Elements
- DC** Directional Controls
- MV** Manual Valves
- SV** Solenoid Valves
- PV** Proportional Valves
- CE** Coils & Electronics
- BC** Bodies & Cavities
- TD** Technical Data

General Description

Priority Type Pressure Compensator. This valve is designed to be used in conjunction with an external orifice (fixed or variable) to provide a constant flow to the priority port. Excess flow is bypassed through port 2. For additional information see Technical Tips on pages FC1-FC4.

Features

- Hardened, precision ground parts for durability
- Stable and quiet response
- Contamination tolerant
- Standard valve bodies and common cavities
- Steel variations and other options available
- All external parts zinc plated

Specifications

Rated Flow	Inlet Flow Setting 95 LPM (25 GPM) 75 LPM (20 GPM)
Maximum Inlet Pressure	380 Bar (5500 PSI)
Cartridge Material	All parts steel. All operating parts hardened steel.
Operating Temp. Range/Seals	-40°C to +93.3°C (Nitrile) (-40°F to +200°F) -31.7°C to +121.1°C (Fluorocarbon) (-25°F to +250°F)
Fluid Compatibility/Viscosity	Mineral-based or synthetic with lubricating properties at viscosities of 45 to 2000 SSU (6 to 420 cSt)
Filtration	ISO Code 16/13, SAE Class 4 or better
Approx. Weight	.28 kg (.62 lbs.)
Cavity	C12-4 (See BC Section for more details)
Form Tool	Rougher NFT12-4R Finisher NFT12-4F

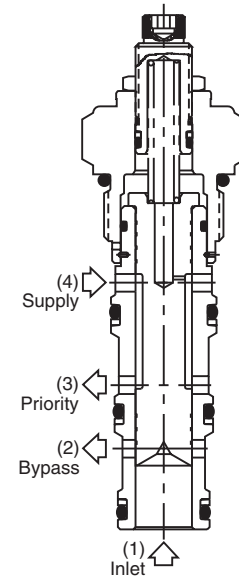
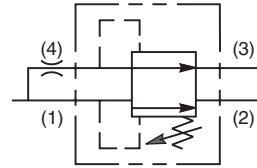

Performance Curve
Flow vs. Orifice Diameter
(Through cartridge only)

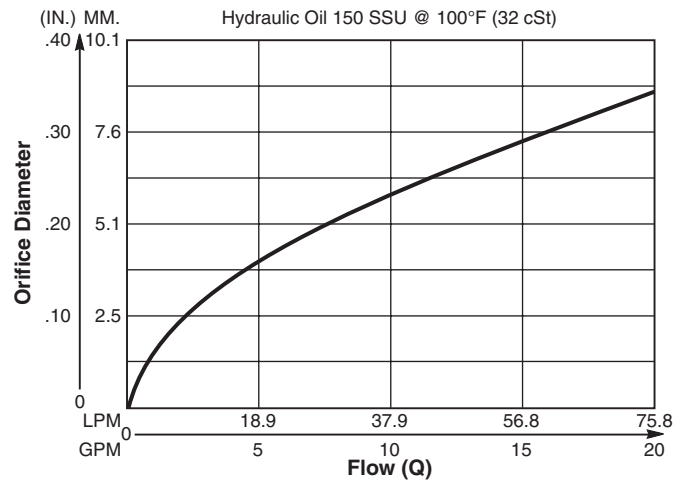

Dimensions Millimeters (Inches)

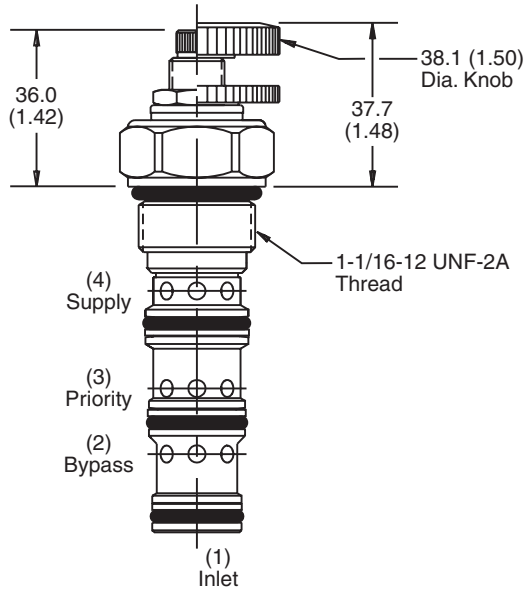

Screw/Knob Version

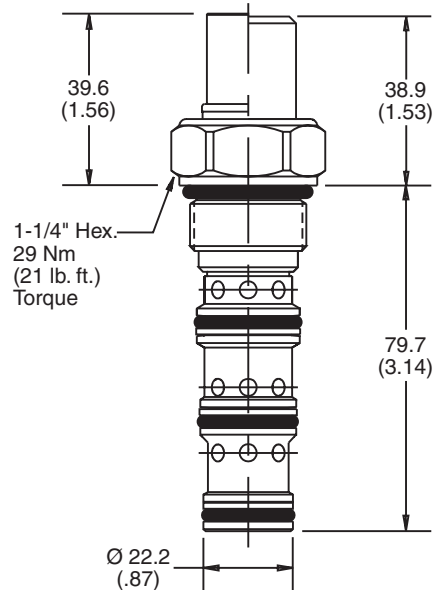

Fixed Cap/Tamper Resistant Version

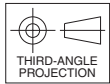

Ordering Information

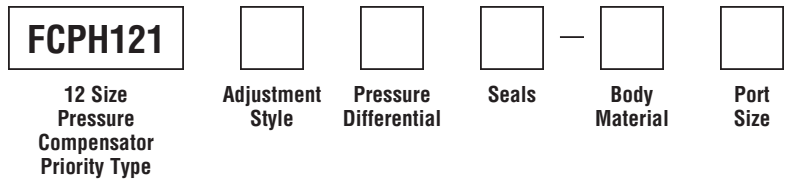

Code	Adjustment Style
F	Fixed style, present at factory
K	Knob Adjust (717784-15)
S	Screw Adjust
T	Tamper Resistant Cap (717785)

Code	Pressure Differential
Omit	11 Bar (160 PSI)

Code	Seals / Kit. No.
Omit	Nitrile / (SK12-4)
V	Fluorocarbon / (SK12-4V)

Code	Body Material
Omit	Steel
A	Aluminum

Code	Port Size	Body Part No.
Omit		Cartridge Only
12T	SAE-12	(B12-4-*12T)

* Add "A" for aluminum, omit for steel.

- CV**
Check Valves
- SH**
Shuttle Valves
- LM**
Load/Motor Controls
- FC**
Flow Controls
- PC**
Pressure Controls
- LE**
Logic Elements
- DC**
Directional Controls
- MV**
Manual Valves
- SV**
Solenoid Valves
- PV**
Proportional Valves
- CE**
Coils & Electronics
- BC**
Bodies & Cavities
- TD**
Technical Data

Technical Information

- CV** Check Valves
- SH** Shuttle Valves
- LM** Load/Motor Controls
- FC** Flow Controls
- PC** Pressure Controls
- LE** Logic Elements
- DC** Directional Controls
- MV** Manual Valves
- SV** Solenoid Valves
- PV** Proportional Valves
- CE** Coils & Electronics
- BC** Bodies & Cavities
- TD** Technical Data

General Description

Flow Divider/Combiner Valve. FDC101 divides flow from a single source proportionally to two actuators. In the reverse mode, flow from two sources is combined into one flow. When dividing or combining flow to synchronize two cylinders, please consider that the flow accuracy is $\pm 10\%$. For additional information see Technical Tips on pages FC1-FC4.

Features

- Hardened, precision ground parts for durability
- Cartridge design
- Ratios of 50-50, 60-40 and 66-33 available
- All external parts zinc plated

Specifications

Maximum Flow	45 LPM (12 GPM) See ordering information
Maximum Inlet Pressure	245 Bar (3500 PSI)
Accuracy	$\pm 10\%$
Cartridge Material	All parts steel. All operating parts hardened steel.
Operating Temp. Range (Ambient)	-40°C to +93.3°C (Nitrile) (-40°F to +200°F) -31.7°C to +121.1°C (Fluorocarbon) (-25°F to +250°F)
Filtration	ISO Code 16/13, SAE Class 4 or better
Fluids	Mineral-based or synthetic with lubricating properties at viscosities of 45 to 2000 SSU (6 to 420 cSt)
Approx. Weight	.14 kg (0.3 lbs.)
Cavity	No. C10-4
Form Tool	Rougher NFT10-4R Finisher NFT10-4F

Note: When machining a manifold using the FDC101, use C10-4 cavity. Do not machine a port that directs flow to the nose of the cavity.

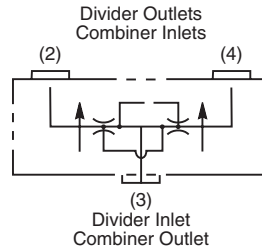
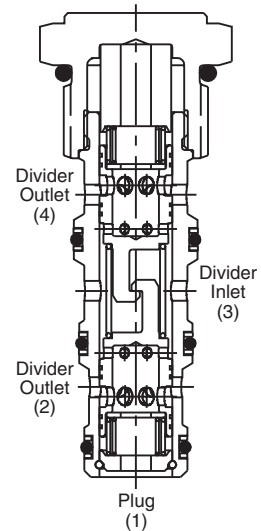
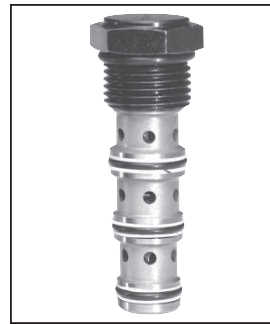

Performance Curve
Flow vs. Pressure Drop
(Through cartridge only)

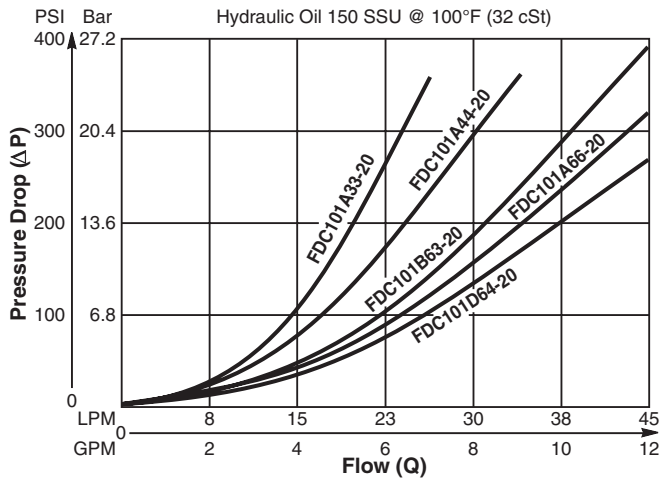

Dimensions Millimeters (Inches)

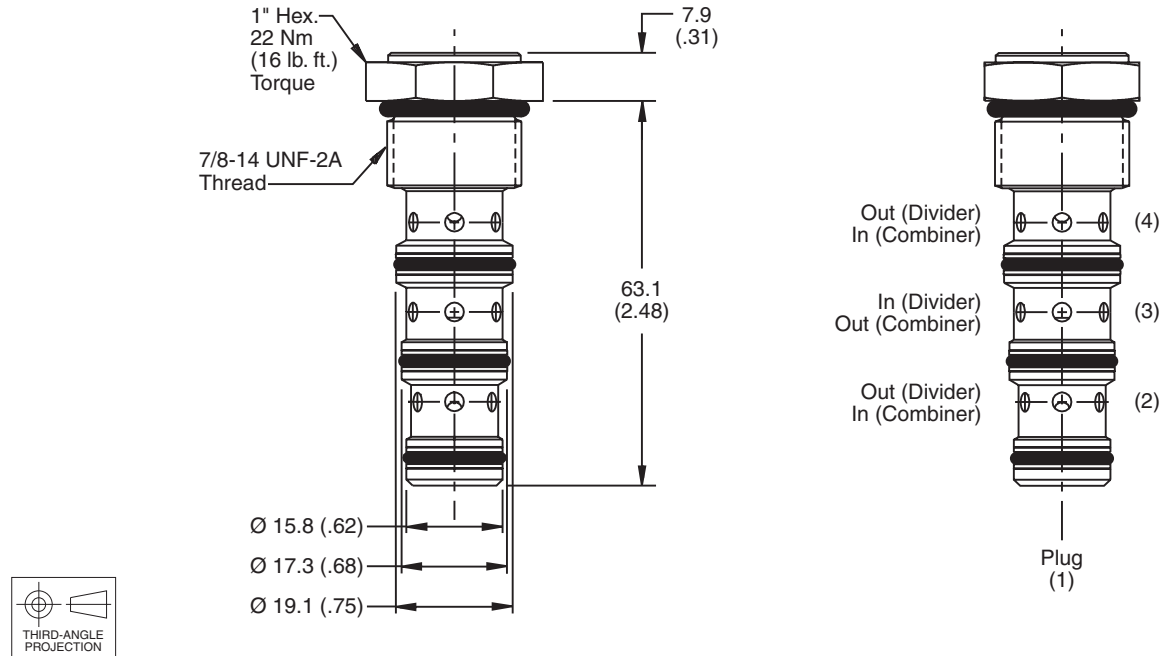

Ordering Information

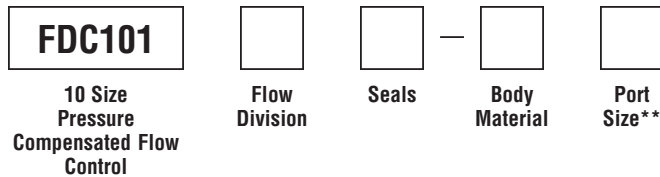

Code	Flow Division
A11	3.80 LPM (1 GPM) min. inlet 11.3 LPM (3 GPM) max. inlet 50% '4' Port and 50% '2' Port
A33	11.3 LPM (3 GPM) min. inlet 22.5 LPM (6 GPM) max. inlet 50% '4' Port and 50% '2' Port
A44	15.0 LPM (4 GPM) min. inlet 30.0 LPM (8 GPM) max. inlet 50% '4' Port and 50% '2' Port
A66	22.5 LPM (6 GPM) min. inlet 45.0 LPM (12 GPM) max. inlet 50% '4' Port and 50% '2' Port
B64	15.0 LPM (4 GPM) min. inlet 37.5 LPM (10 GPM) max. inlet 60% '4' Port and 40% '2' Port
D63	11.3 LPM (3 GPM) min. inlet 33.8 LPM (9 GPM) max. inlet 33% '4' Port and 66% '2' Port

Code	Seals / Kit. No.
Omit	Nitrile / (SK10-4N)
V	Fluorocarbon / (SK10-4V)

Code	Body Material
Omit	Steel
A	Aluminum

Code	Port Size	Body Part No.
Omit	Cartridge Only	
6P	3/8" NPTF	(B10-4-*6P)
6T	SAE-6	(B10-4-*6T)
8T	SAE-8	(B10-4-*8T)
6B	3/8" BSPG	(B10-4-6B)†

* Add "A" for aluminum, omit for steel.
 † Steel body only.

**The FDC101 cartridge has three ports. Due to its size, it requires a B10-4 series body. As a result, all cartridges in a body will be supplied with a plug located 180° from the cartridge cavity (port 1).

- B10-4-6T body — 6HP*50-S
- B10-4-8T body — 8HP*50-S
- B10-4-4P body — 102 x 4
- B10-4-6P body — 102 x 6
- B10-4-8P body — 102 x 8

When machining a manifold using the FDC101, use C10-4 cavity. Do not machine a port that directs flow to the nose of the cavity.

Technical Information

- CV** Check Valves
- SH** Shuttle Valves
- LM** Load/Motor Controls
- FC** Flow Controls
- PC** Pressure Controls
- LE** Logic Elements
- DC** Directional Controls
- MV** Manual Valves
- SV** Solenoid Valves
- PV** Proportional Valves
- CE** Coils & Electronics
- BC** Bodies & Cavities
- TD** Technical Data

General Description

Spool Type, Flow Divider/Combiner Valve. For additional information see Technical Tips on pages FC1-FC4.

Features

- Interlocking spools for equal control dividing or combining
- Range of flow settings available for optimising control
- Pressure compensated control in both directions
- 50/50 ratio standard, other ratios available on request
- Commonly used for differential lock in transmission applications
- Hardened working parts for maximum durability
- All external parts zinc plated

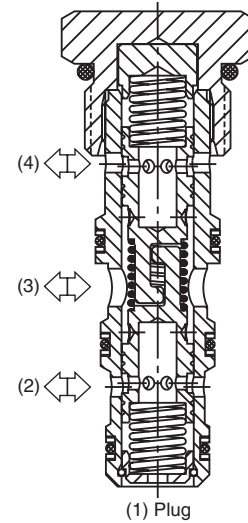
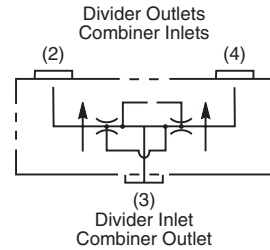

Specifications

Rated Flow	60 LPM (16 GPM)
Maximum Inlet Pressure	420 Bar (6000 PSI)
Flow Rating and Ratio	See Ordering Information
Accuracy Per Leg	± 10%
Cartridge Material	All parts steel. All operating parts hardened steel.
Operating Temp. Range/Seals	-40°C to +93.3°C (Nitrile) (-40°F to +200°F) -31.7°C to +121.1°C (Fluorocarbon) (-25°F to +250°F)
Fluid Compatibility/ Viscosity	Mineral-based or synthetic with lubricating properties at viscosities of 45 to 2000 SSU (6 to 420 cSt)
Filtration	ISO Code 16/13, SAE Class 4 or better
Approx. Weight	.12 kg (0.26 lbs.)
Cavity	C10-4 (See BC Section for more details)
Form Tool	Rougher NFT10-4R Finisher NFT10-4F

Performance Curve

Pressure Drop vs. Flow (Through cartridge only)

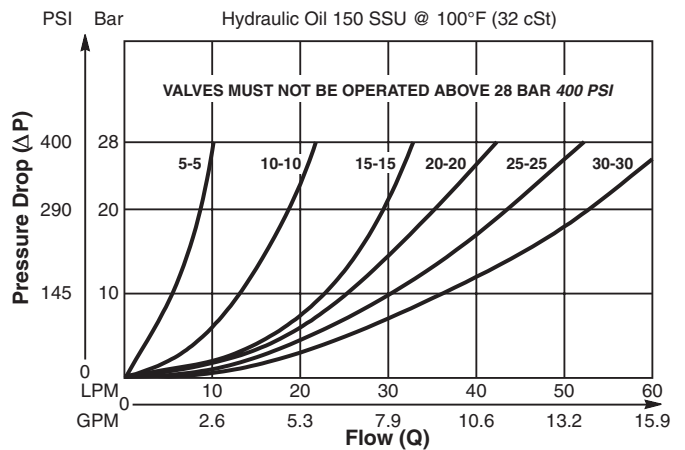

Dimensions Millimeters (Inches)

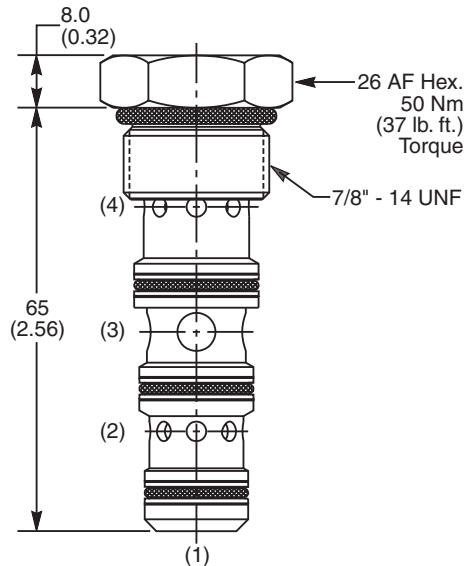

Ordering Information

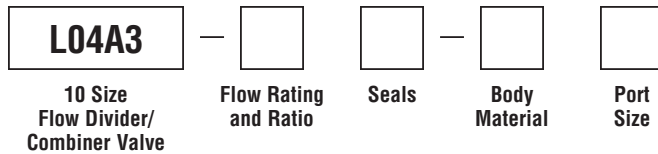

Code	Total Flow Rating - Port 2 (Flow Ratio)
5-5	6-10 LPM (1.6-2.6 GPM) (50/50 Ratio)
10-10	8-20 LPM (2.1-5.3 GPM) (50/50 Ratio)
15-15	10-30 LPM (2.6-7.9 GPM) (50/50 Ratio)
20-20	12-40 LPM (3.2-10.6 GPM) (50/50 Ratio)
25-25	13-50 LPM (3.4-13.2 GPM) (50/50 Ratio)
30-30	14-60 LPM (3.7-15.9 GPM) (50/50 Ratio)

Other ratios and ratings available on request.

Code	Seals / Kit. No.
N	Nitrile, Buna-N (Std.) / (SK30506N-1)
V	Fluorocarbon / (SK30506V-1)

Code	Body Material
Omit	Steel
A	Aluminum

Code	Port Size	Body Part No.
Omit	Cartridge Only	
6P	3/8" NTPF	(B10-4-*6P)
6T	SAE-6	(B10-4-*6T)
8T	SAE-8	(B10-4-*8T)
6B	3/8" BSPG	(B10-4-6B)†

** Add "A" for aluminum, omit for steel.
 † Steel bodies only*

Technical Information

- CV** Check Valves
- SH** Shuttle Valves
- LM** Load/Motor Controls
- FC** Flow Controls
- PC** Pressure Controls
- LE** Logic Elements
- DC** Directional Controls
- MV** Manual Valves
- SV** Solenoid Valves
- PV** Proportional Valves
- CE** Coils & Electronics
- BC** Bodies & Cavities
- TD** Technical Data

General Description

Spool Type, Flow Divider/Combiner Valve. For additional information see Technical Tips on pages FC1-FC4.

Features

- Interlocking spools for equal control dividing or combining
- Range of flow settings available for optimising control
- Pressure compensated control in both directions
- 50/50 ratio standard, other ratios available on request
- Commonly used for differential lock in transmission applications
- Hardened working parts for maximum durability
- All external parts zinc plated

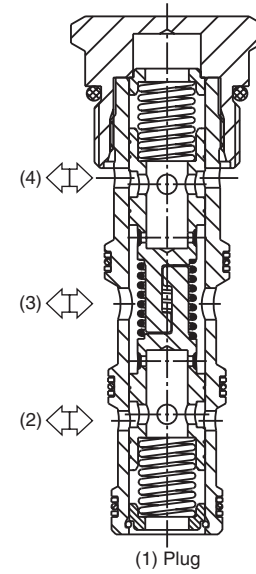
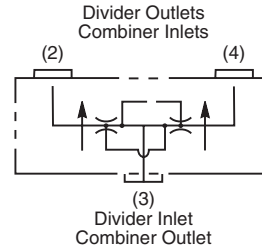
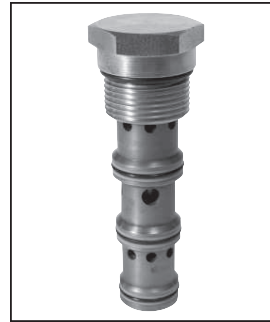

Specifications

Rated Flow	180 LPM (47 GPM)
Maximum Inlet Pressure	420 Bar (6000 PSI)
Flow Rating and Ratio	See Ordering Information
Accuracy Per Leg	± 10%
Cartridge Material	All parts steel. All operating parts hardened steel.
Operating Temp. Range/Seals	-40°C to +93.3°C (Nitrile) (-40°F to +200°F) -31.7°C to +121.1°C (Fluorocarbon) (-25°F to +250°F)
Fluid Compatibility/ Viscosity	Mineral-based or synthetic with lubricating properties at viscosities of 45 to 2000 SSU (6 to 420 cSt)
Filtration	ISO Code 16/13, SAE Class 4 or better
Approx. Weight	.40 kg (0.86 lbs.)
Cavity	C16-4 (See BC Section for more details)
Form Tool	Rougher Finisher

Performance Curve

Pressure Drop vs. Flow (Through cartridge only)

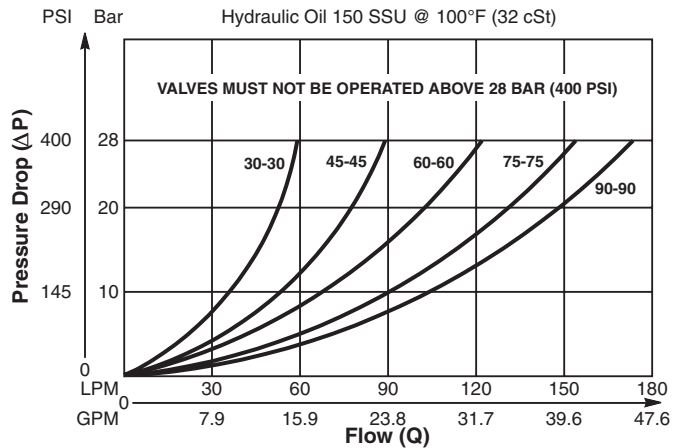

Dimensions Millimeters (Inches)

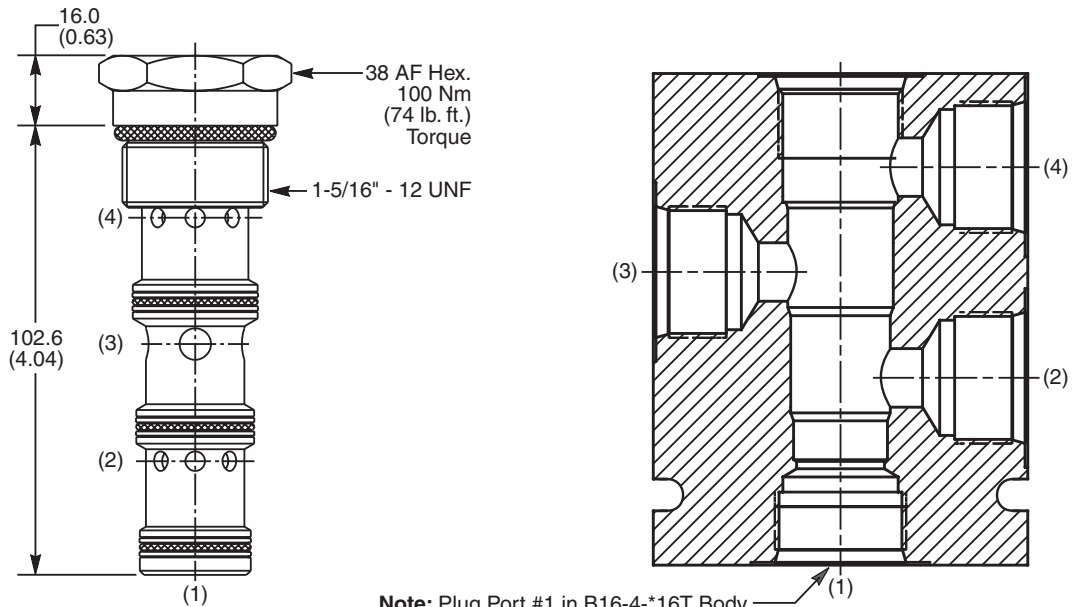

Note: Plug Port #1 in B16-4-*16T Body, use Parker #16HP50N-S Hollow Hex Plug.

Ordering Information

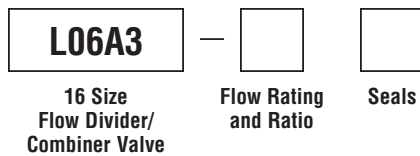

Code	Total Flow Rating - Port 2 (Flow Ratio)
30-30	20-60 LPM (5.3-15.9 GPM) (50/50 Ratio)
45-45	25-90 LPM (6.6-23.8 GPM) (50/50 Ratio)
60-60	35-120 LPM (9.2-31.7 GPM) (50/50 Ratio)
75-75	55-150 LPM (14.6-39.6 GPM) (50/50 Ratio)
90-90	65-180 LPM (17.2-47.8 GPM) (50/50 Ratio)

Other ratios and ratings available on request.

Code	Seals / Kit. No.
N	Nitrile, Buna-N (Std.) / (SK30510N-1)
V	Fluorocarbon / (SK30510V-1)

Order Bodies Separately

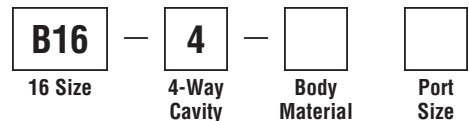

Code	Body Material
Omit	Steel
A	Aluminum

Code	Port Size	Body Part No.
Omit	Cartridge Only	
16T	SAE-16	(B16-4-*16T)

* Add "A" for aluminum, omit for steel.

- CV**
Check Valves
- SH**
Shuttle Valves
- LM**
Load/Motor Controls
- FC**
Flow Controls
- PC**
Pressure Controls
- LE**
Logic Elements
- DC**
Directional Controls
- MV**
Manual Valves
- SV**
Solenoid Valves
- PV**
Proportional Valves
- CE**
Coils & Electronics
- BC**
Bodies & Cavities
- TD**
Technical Data

Technical Information

- CV** Check Valves
- SH** Shuttle Valves
- LM** Load/Motor Controls
- FC** Flow Controls
- PC** Pressure Controls
- LE** Logic Elements
- DC** Directional Controls
- MV** Manual Valves
- SV** Solenoid Valves
- PV** Proportional Valves
- CE** Coils & Electronics
- BC** Bodies & Cavities
- TD** Technical Data

General Description

Spool Type, Flow Divider/Combiner Valve. For additional information see Technical Tips on pages FC1-FC4.

Features

- Interlocking spools for equal control dividing or combining
- Range of flow settings available for optimising control
- Pressure compensated control in both directions
- 50/50 ratio standard, other ratios available on request
- Commonly used for differential lock in transmission applications
- Hardened working parts for maximum durability
- All external parts zinc plated

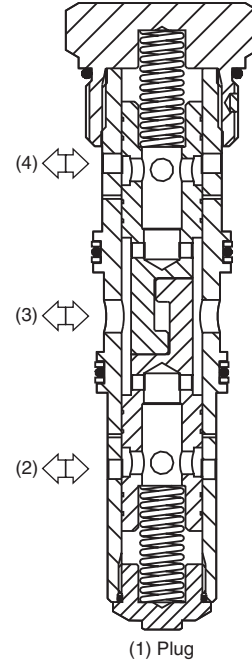
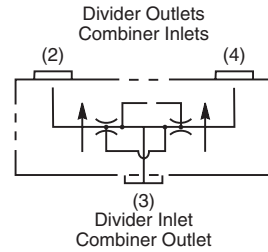
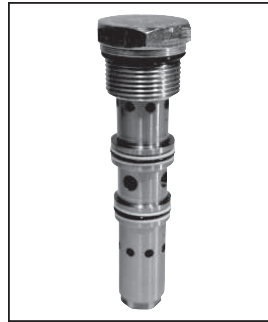

Specifications

Rated Flow	320 LPM (85 GPM)
Maximum Inlet Pressure	350 Bar (5000 PSI)
Flow Rating and Ratio	See Ordering Information
Accuracy Per Leg	± 10%
Cartridge Material	Steel operating parts, hardened steel poppet.
Operating Temp. Range/Seals	-40°C to +93.3°C (Nitrile) (-40°F to +200°F) -31.7°C to +121.1°C (Fluorocarbon) (-25°F to +250°F)
Fluid Compatibility/ Viscosity	Mineral-based or synthetic with lubricating properties at viscosities of 45 to 2000 SSU (6 to 420 cSt)
Filtration	ISO Code 16/13, SAE Class 4 or better
Approx. Weight	1.0 kg (2.2 lbs.)
Cavity	91-1 (See BC Section for more details)
Form Tool	Rougher Finisher

Performance Curve

Pressure Drop vs. Flow (Through cartridge only)

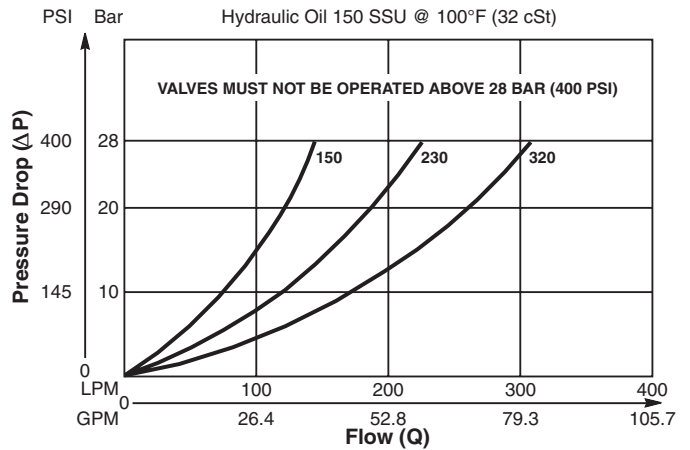

Dimensions Millimeters (Inches)

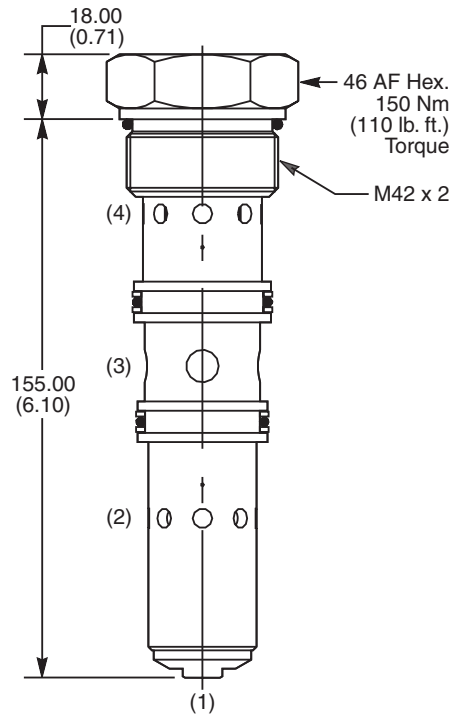

Ordering Information

L1A300	<input type="checkbox"/>	<input type="checkbox"/>	<input type="checkbox"/>
Flow Divider/ Combiner Valve	Flow Rating	Dividing/ Combiner Ratio	Seals

Code	Flow Rating
150	60-150 LPM (15.9-39.7 GPM)
230	75-230 LPM (19.8-60.8 GPM)
320	110-320 LPM (29.1-84.7 GPM)

Code	Seals / Kit. No.
N	Nitrile, Buna-N (Std.)/ (SK30050N-1)
V	Fluorocarbon / (SK30050V-1)

Code	Dividing/Combiner Ratio
5050	50 : 50 Ratio

Other ratios available on request.

Order Bodies Separately

LB10	<input type="checkbox"/>	<input type="checkbox"/>
Line Body	Porting	Body Material

Code	Porting
156	2 x 1" BSP 1 x 1-1/2" BSP
157	2 x 1" SAE 1 x 1-1/2" SAE

Code	Body Material
A	Aluminum
S	Steel

- CV**
Check Valves
- SH**
Shuttle Valves
- LM**
Load/Motor Controls
- FC**
Flow Controls
- PC**
Pressure Controls
- LE**
Logic Elements
- DC**
Directional Controls
- MV**
Manual Valves
- SV**
Solenoid Valves
- PV**
Proportional Valves
- CE**
Coils & Electronics
- BC**
Bodies & Cavities
- TD**
Technical Data

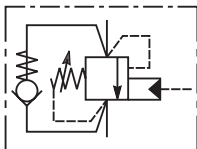
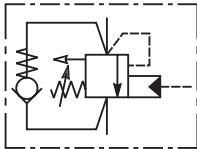
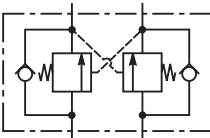
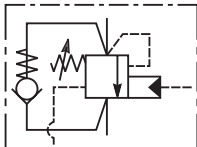
	SERIES	CAVITY	DESCRIPTION	FLOW LPM/GPM	PRESSURE BAR/PSI	PAGE NO.	
	STANDARD PILOT ASSISTED						
	CB101	C10-3	Load Control Cartridge Valve	45/12	380/5500	LM5-LM6	
	MHC-010-S***	CDD-1010	Load Control Cartridge Valve	37/10	350/5000	LM7-LM8	
	MHC-022-S***	CDD-1036	Load Control Cartridge Valve	94/25	350/5000	LM9-LM10	
	MHB-015-L***		Load Control Valve Assembly	56/15	207/3000	LM11-LM13	
	MHB-030-L***		Load Control Valve Assembly	113/30	207/3000	LM14-LM16	
	E2*020	53-1	Load Control Cartridge Valve	20/5.3	420/6000	LM17-LM18	
	E2*040	68-1	Load Control Cartridge Valve	60/16	350/5000	LM19-LM20	
	E2*1	T11-A	Load Control Cartridge Valve	60/16	350/5000	LM21-LM22	
	E2*1S	T11-A	Load Control Cartridge Valve	60/16	350/5000	LM23-LM24	
	E2*1R	T11-A	Load Control Cartridge Valve	60/16	350/5000	LM25-LM26	
	E2*060	3C	Load Control Cartridge Valve	120/32	350/5000	LM27-LM28	
	E2*125	3M	Load Control Cartridge Valve	200/53	350/5000	LM29-LM30	
E2*300	3K Flange		350/90	350/5000	LM31-LM32		
	INDEPENDENT OF BACK-PRESSURE, VENTED TO ATMOSPHERE						
	E6B020	53-1	Load Control Cartridge Valve, 4.5:1 Ratio	20/5.3	350/5000	LM33-LM34	
	E6K020	53-1	Load Control Cartridge Valve, 15:1 Ratio	20/5.3	350/5000	LM35-LM36	
	E6*1	T11-A	Load Control Cartridge Valve	60/16	350/5000	LM37-LM38	
	E6B040	68-1	Load Control Cartridge Valve, 3:1 Ratio	60/16	350/5000	LM39-LM40	
	E6A060*409	3C	Load Control Cartridge Valve, 3:1 Ratio	180/48	350/5000	LM41-LM42	
	E6B060*409	3C	Load Control Cartridge Valve, 3:1 Ratio	180/48	350/5000	LM41-LM42	
	MHC-010-V***	CDD-1010	Load Control Cartridge Valve	37/10	350/5000	LM7-LM8	
	MHC-022-V***	CDD-1036	Load Control Cartridge Valve	94/25	350/5000	LM9-LM10	
	MHB-015-W***		Load Control Valve Assembly	56/15	207/3000	LM11-LM13	
	MHB-030-W***		Load Control Valve Assembly	113/30	207/3000	LM14-LM16	
		Dual Motor Control					
		MMB-015-****		Motor Load Control	56/15	207/3000	LM43-LM45
MMB-025-****		Motor Load Control	94/25	207/3000	LM46-LM48		
	INDEPENDENT OF BACK-PRESSURE, VENTED TO DRAIN ON PORT 4						
E9*1	T21A	Load Control Cartridge Valve	60/16	350/5000	LM49-LM50		

- CV**
Check Valves
- SH**
Shuttle Valves
- LM**
Load/Motor Controls
- FC**
Flow Controls
- PC**
Pressure Controls
- LE**
Logic Elements
- DC**
Directional Controls
- MV**
Manual Valves
- SV**
Solenoid Valves
- PV**
Proportional Valves
- CE**
Coils & Electronics
- BC**
Bodies & Cavities
- TD**
Technical Data

- CV** Check Valves
- SH** Shuttle Valves
- LM** Load/Motor Controls
- FC** Flow Controls
- PC** Pressure Controls
- LE** Logic Elements
- DC** Directional Controls
- MV** Manual Valves
- SV** Solenoid Valves
- PV** Proportional Valves
- CE** Coils & Electronics
- BC** Bodies & Cavities
- TD** Technical Data

Introduction

Counterbalance valves are one of the most misunderstood products in the hydraulic industry. Many people tend to complicate the task of selecting a counterbalance valve and as such avoid opportunities. The goal of this Technical Tips Section is to hopefully eliminate some of this confusion and help you choose the correct valve for your application. It is only a guide! It is not meant to be your only method of input, nor is it meant to replace good hydraulic common sense and reasoning.

Application

DO I NEED A COUNTERBALANCE VALVE?

A counterbalance is generally used for one or more of the following purposes:

Control an Overrunning Load – It restricts the flow from an actuator, thus forcing the load to be pushed through the restriction and providing control of the potential runaway load. This also helps in the prevention of cavitation.

Control in Critical Metering Applications – The outward restriction also helps to gain control of systems with varying loads and speeds.

Holding a Load – Much like a pilot operated check valve, a load is held in one direction until the appropriate pilot pressure is available unseat the check and pass fluid.

Help Protect Against Hose Failures – Since the fluid must be pushed through a restriction, hose failures result in a controlled movement of the actuator and not a runaway load.

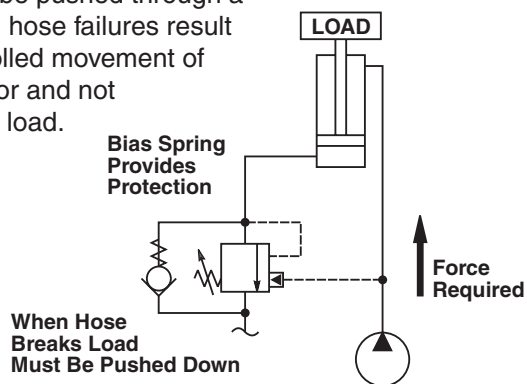

NOTE: Counterbalance Valves are only needed if the application calls for varying loads or varying speeds. If the load and speed are fixed, flow control valves and pilot operated check valves may be substituted at generally a lower cost.

Operation

An understanding of the general operation of a counterbalance valve is required before proceeding further into valve selection.

The counterbalance valve is a pressure control device and functions as follows: Pressure is developed at the Work Port of the holding valve when the actuator is pressurized. This pressure acts on the differential area, and the force generated is counteracted by the bias spring. When there is sufficient pressure present to overcome the spring setting, the poppet begins to shift, allowing fluid to pass through the valve port to tank via the control valve.

To assist in the shifting of the poppet, an external pressure source (generally the opposite side of the actuator) is connected to the pilot port of the counterbalance valve. This pressure is applied to the pilot area and assists the differential area in opening the valve. The pilot assist reduces load pressure required to open the valve, and allows for a reduction in the horsepower required to move the load. If the load attempts to “run away” (move faster than the pump can supply flow), the pilot signal will diminish and the piston will begin to close restricting flow to tank and thus controlling the load. The counterbalance piston will maintain a position that maintains a positive pilot signal and will control the descent of the load.

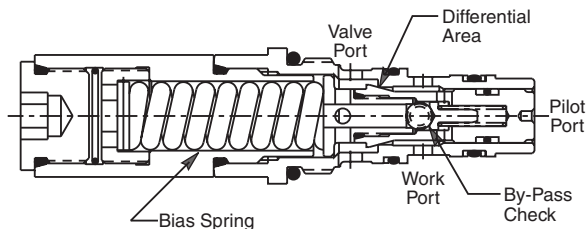

An added feature of the counterbalance valve is its built-in thermal relief characteristic. A temperature rise can cause thermal expansion of the hydraulic fluid trapped between the actuator and the counterbalance valve’s poppet. As the pressure increases and reaches the bias spring setting, the poppet unseats and a few drops of oil are allowed to escape through the valve port of the counterbalance valve. This relieves the thermal expansion of oil, allowing the counterbalance valve to continue holding the load in the same position. When the flow is reversed to the actuator, then pressure unseats the built-in bypass check portion of the counterbalance valve allowing flow to pass from the valve port to the work port. When no pressure is applied to either port of the counterbalance valve, the load is held in place.

Valve Series

Parker offers the four series of products outlined below:

MHC – The MHC series is a threaded cartridge style counterbalance valve. This series is ideal for incorporating into an integrated manifold or for installation directly into the port of the actuator. There are various flow rates and pilot ratios available for the MHC Series.

CB101 – The CB101 is also a threaded cartridge style counterbalance valve. It also is ideal for incorporating into an integrated manifold or for installation directly into the port of the actuator. The CB101 has an industry common cavity (C10-3) and is available in three pilot ratios.

E2 Series – The E2 Series valves are threaded cartridge style counterbalance valves. They are available in standard and Vented configurations. In the Vented configurations, the valves maintain their settings regardless of system backpressure. There are various flow rates and pilot ratios available.

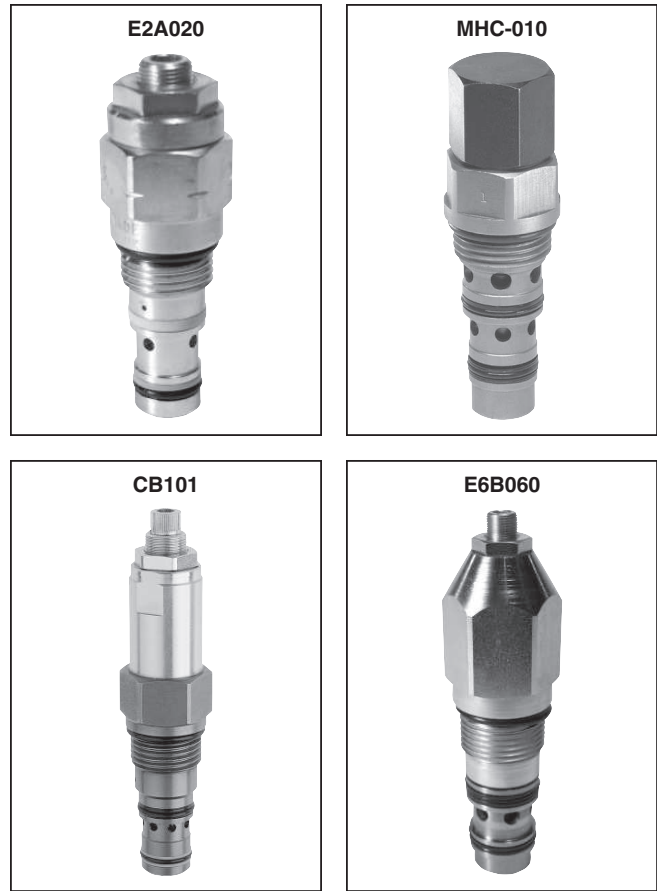

Selecting Options

Below is a brief description of the options available on the ordering information pages and a brief explanation of when each would be used.

Flow Selection – Generally the counterbalance valve is sized according to the actual flow the valve will see and not the system flow. Note that the ordering information callout is the nominal flow rate and not the maximum. In other words, refer to the pressure drop curves when sizing the valves. For example: A MHC-010 can flow 25 GPM, but is rated as a 10 GPM valve. It is possible to oversize a counterbalance valve! If the counterbalance is oversized, the annulus between the poppet and the seat is too large, thus the poppet opens too far causing instability. Remember you are gaining control by causing a restriction. If you oversize the counterbalance valve, the restriction is reduced and so is the control.

Vented versus Non-Vented – With a standard counterbalance valve, the bias spring is internally vented to tank. This means any pressure on the tank line is sensed in the bias spring chamber and additive to the setting. Thus, the pressure at the work port now must

be greater than the bias spring plus the tank pressure before the counterbalance poppet will shift allowing flow.

A vented style counterbalance valve relieves the bias spring chamber to atmosphere. Thus, the spring chamber is in no way related to the tank chamber of the counterbalance valve. So, if the pressure on the tank line is high, or if the pressure setting is critical, then a vented style counterbalance valve would be required.

Parker's counterbalance valves are externally vented. This means no extra porting or manifold costs are incurred when a vented counterbalance is needed.

MHC-010-S*S* Non-Vented Counterbalance Adjustable

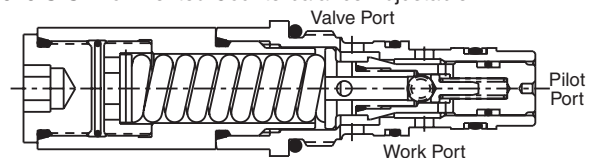

MHC-010-V*S* Vented Counterbalance Adjustable

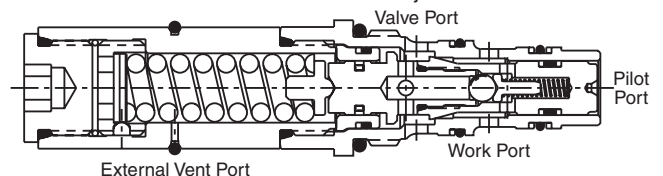

CV

Check Valves

SH

Shuttle Valves

LM

Load/Motor Controls

FC

Flow Controls

PC

Pressure Controls

LE

Logic Elements

DC

Directional Controls

MV

Manual Valves

SV

Solenoid Valves

PV

Proportional Valves

CE

Coils & Electronics

BC

Bodies & Cavities

TD

Technical Data

- CV Check Valves
- SH Shuttle Valves
- LM Load/Motor Controls
- FC Flow Controls
- PC Pressure Controls
- LE Logic Elements
- DC Directional Controls
- MV Manual Valves
- SV Solenoid Valves
- PV Proportional Valves
- CE Coils & Electronics
- BC Bodies & Cavities
- TD Technical Data

Selection Options (Continued)

Pilot Ratio – The pilot ratio is the ratio of the pilot area versus the differential area poppet. Thus, the higher the pilot ratio, the less pressure that is needed to assist the load pressure in unseating the poppet. This means there is less restriction to the overrunning load, resulting in less horsepower required and more control of the load. So higher pilot ratio equates to less restriction to the overrunning load, less control and less horsepower required. Lower ratio equates to more restriction to the overrunning load, more control and more horse-

power required. The pilot ratio decision is one of Horsepower versus Control. For reference the most popular ratio is 6:1.

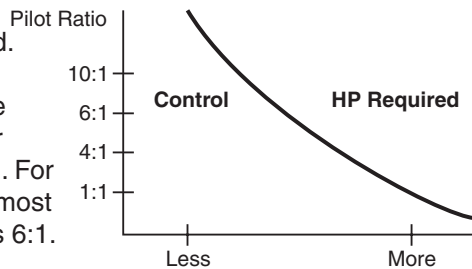

Sample Ratios:

10:1

Primary function is load holding or hose break protection
Loads moving at fast speeds and positioning is not critical

7:1, 6:1 and 5:1

Most popular starting ratio

4:1 and 3:1

Positioning is critical such as a pick and place application
Instability with 6:1 ratio

1:1

Motor control application

ADJUSTMENT TYPE

Parker offers counterbalance valves with adjustable and non-adjustable pressure settings. The non-adjustable or shimmed version is recommended for most applications as it prevents tampering or improper adjustment by uneducated end users.

SELECTING SETTINGS

There are three basic settings to consider before finalizing a counterbalance valve for your application.

Holding Setting – The holding setting is sometimes referred to as the counterbalance setting. It is the maximum load setting you expect the counterbalance to hold. Note that the counterbalance valve should be set for the absolute maximum hold pressure required. Also note that counterbalance valves are restrictive type devices and as such are not ideal for low pressure applications, such as those below 750 psi. The holding setting is the setting you choose when selecting a counterbalance valve.

Thermal Setting – Counterbalance valves have a built-in thermal relief valve that compensates for the expansion of oil, due to temperature, by bleeding off excess pressure. In other words, the thermal setting is the pressure that the counterbalance will unload at if no pressure is present at the pilot port. Obviously, this setting should be above the holding setting. The Parker **MHC** counterbalance valves are automatically set 1000 psi above the holding setting of the valve. **You do not specify this setting, only the holding setting.** For the **CB101** Series, you do specify the Thermal/Crack setting in the model code. The holding setting (maximum load induced pressure) is 70% of that specified setting. Example: Hold at 3000 psi, crack at 4285 psi. For the **E2** Series, you specify the Thermal/Crack setting in the model code. The crack setting (maximum load induced pressure) should be 1.3 times the hold. Example: Hold at 3000 psi, crack at 3900 psi.

Pilot Area – The pilot pressure required to lower the cylinder when fully loaded and unloaded can also be determined before applying the valve. The pilot pressure can be determined by the below equation:

$$P_p = (T_s - L) / R_p$$

- P_p = Pilot Pressure
- T_s = Thermal Setting
- L = Induced Load
- R_p = Pilot Ratio

Example:

The maximum load is 3000 psi. A 6:1 Pilot Ratio was chosen and the thermal relief setting is the standard 1000 psi over load setting. What is the pilot pressure required to retract the cylinder if it is fully loaded? What pilot pressure is required to retract the cylinder if there is no load?

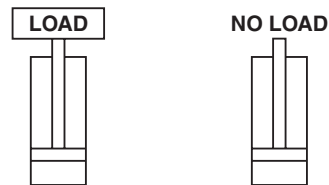

FULLY LOADED:

$$P_p = (4000 \text{ psi} - 3000 \text{ psi}) / 6$$

$$P_p = 1000 \text{ psi} / 6$$

$$P_p = 167 \text{ psi}$$

Thus, any time the pilot line sees at least 167 psi, the cylinder could lower the load.

UNLOADED:

$$P_p = (4000 \text{ psi} - 0 \text{ psi}) / 6$$

$$P_p = 4000 \text{ psi} / 6$$

$$P_p = 667 \text{ psi}$$

Thus, at least 667 psi will be needed to lower the cylinder when it is unloaded.

Motor Controls

Counterbalance valves are used in motor circuits to stop overrunning loads and prevent cavitation. Since hydraulic motors leak internally, the counterbalance valve by itself cannot be used to hold the load. So, a mechanical brake is used to hold the load on the motor in place, as shown below. Some typical applications include winches, swing drives, conveyor control and traction drives. For applications in closed loop motor circuits, vented spring cavities are required.

Operation

Free flow to the motor is allowed through the internal check valve. In the controlled flow direction, the oil passes across a metering poppet. The position of the metering poppet is determined by an external pilot signal from the other side of the motor. In an open loop motor circuit, this pilot signal will be a 1:1 ratio. The reason an equal ratio pilot signal is utilized is to provide positive control as well as to release mechanical brakes (when used in a braking circuit). In applications where the motor will see overrunning loads in both directions (such as a traction drive circuit), a dual MMB or two single MMB valves must be used.

Brake Applications

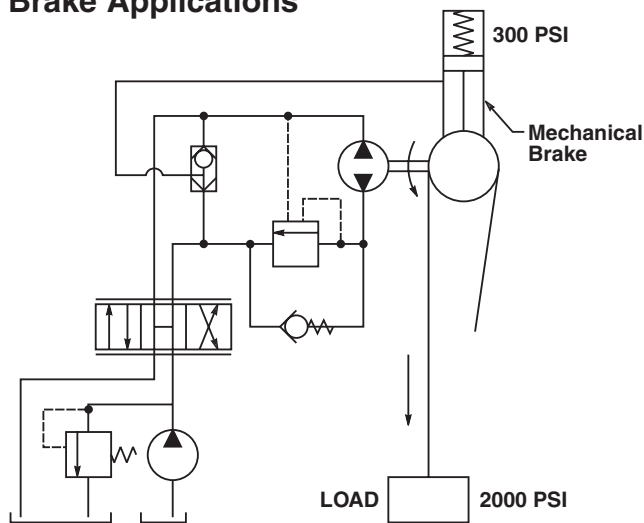

When the directional control valve is shifted, hydraulic pressure (usually 300 psi) releases the mechanical brake and allows the load to be moved. The counterbalance valve needs to provide adequate back pressure to open the brake, then immediately counterbalance the load. Ideally, the brake will be disengaged before the motor begins to rotate. If this sequence is not achieved, the motor will try to rotate against the applied brake reducing the life of the brake. This would be the equivalent of trying to drive with your emergency brake applied. Remember that hydraulic motors are equal area devices. So, in an effort to avoid the

movement of the motor prior to the release of the brake, an equal area ratio counterbalance is used. To demonstrate let's look again at the above example with a 10:1 Ratio Counterbalance valve installed and a maximum thermal setting of 3000 psi.

10:1 Example

NO LOAD

$$P_p = (T_s - L) / R_p$$

$$P_p = (3000 \text{ psi} - 0 \text{ psi}) / 10$$

$$P_p = 3000 \text{ psi} / 10$$

$$P_p = 300 \text{ psi}$$

2000 PSI LOAD

$$P_p = (T_s - L) / R_p$$

$$P_p = (3000 \text{ psi} - 2000 \text{ psi}) / 10$$

$$P_p = 1000 \text{ psi} / 10$$

$$P_p = 100 \text{ psi}$$

Thus, when there is no load on the motor, the counterbalance opens at 300 psi, or just as the brake is being released. When there is a 2000 psi load on the motor, the counterbalance will start to open with a pilot pressure of 100 psi. The brake requires 300 psi, so the motor can start to rotate before the brake is released, causing wear on the brake. To offset this problem, you could increase the maximum thermal setting to 5000 psi, but this is very inefficient.

1:1 (Equal Area) Example

Equal area counterbalance valves are used primarily in brake applications to avoid the wear problem described above. With an Equal Area counterbalance valve, there is no thermal relief valve, and there is no differential area to work on. In other words, the counterbalance valve only opens when the pilot pressure is greater than the valve setting. The applied load has nothing to do with the pilot pressure required. Thus you will want to choose a pressure setting for the equal area counterbalance valve that is just slightly above the brake release pressure (usually 350 psi).

In our example, the valve would be set at 350 psi. This would allow the brake to release before the counterbalance allows the load to move. Since the equal counterbalance valve always opens at 350 psi pilot pressure and is not dependent on the load, it is the best valve for brake applications.

Large Pressure Spike Application – Keep in mind that equal area counterbalance valves do not have a built-in thermal relief valve. As such, if there are large pressure spikes caused by the stopping of heavy loads, then a ratioed counterbalance, such as a 10:1 should be used. In most cases these are non-brake type applications.

CV
Check Valves
SH
Shuttle Valves
LM
Load/Motor Controls
FC
Flow Controls
PC
Pressure Controls
LE
Logic Elements
DC
Directional Controls
MV
Manual Valves
SV
Solenoid Valves
PV
Proportional Valves
CE
Coils & Electronics
BC
Bodies & Cavities
TD
Technical Data

Technical Information

- CV Check Valves
- SH Shuttle Valves
- LM Load/Motor Controls
- FC Flow Controls
- PC Pressure Controls
- LE Logic Elements
- DC Directional Controls
- MV Manual Valves
- SV Solenoid Valves
- PV Proportional Valves
- CE Coils & Electronics
- BC Bodies & Cavities
- TD Technical Data

General Description

Cartridge Style Counterbalance Valve.
For additional information see Technical Tips on pages LM1-LM4.

Features

- Sealed spool type design for improved stability and accuracy as well as low leakage
- Low leakage poppet-type check valve for reliable load holding
- All external parts have yellow zinc dichromate finish.
- Parker cartridge design for ease of installation and maintenance
- Compact size for reduced space requirements

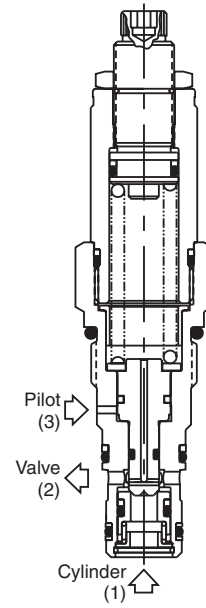
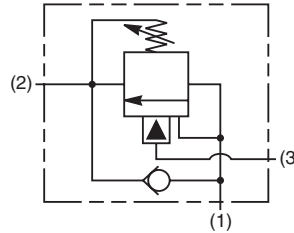
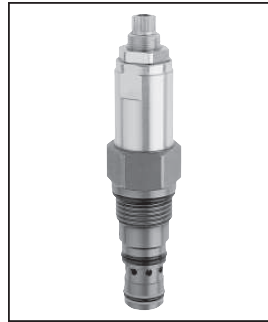

Specifications

Rated Flow	45 LPM (12 GPM)
Maximum Inlet Pressure	380 Bar (5500 PSI) - Steel 210 Bar (3000 PSI) - Aluminum
Maximum Setting Pressure	350 Bar (5000 PSI) - Steel 210 Bar (3000 PSI) - Aluminum
Leakage at 150 SSU (32 cSt)	5 drops/min. (.33 cc/min.) @ 80% of thermal crack pressure
Cartridge Material	All parts steel. All operating parts hardened steel.
Operating Temp. Range/Seals	-40°C to +93.3°C (Nitrile) (-40°F to +200°F) -31.7°C to +121.1°C (Fluorocarbon) (-25°F to +250°F)
Fluid Compatibility/Viscosity	Mineral-based or synthetic with lubricating properties at viscosities of 45 to 2000 SSU (6 to 420 cSt)
Filtration	ISO Code 16/13, SAE Class 4 or better
Approx. Weight	.23 kg (0.5 lbs.)
Cavity	C10-3 (See BC Section for more details)
Form Tool	Rougher NFT10-3R Finisher NFT10-3F

Performance Curve
Flow vs. Pressure Drop
(Through cartridge only)

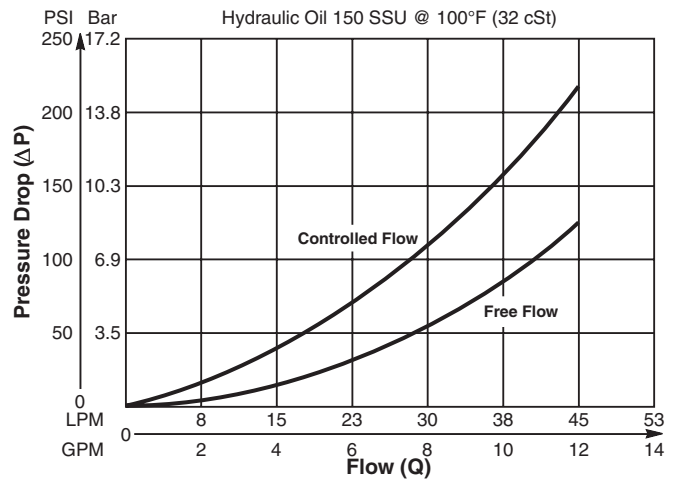

Dimensions Millimeters (Inches)

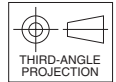
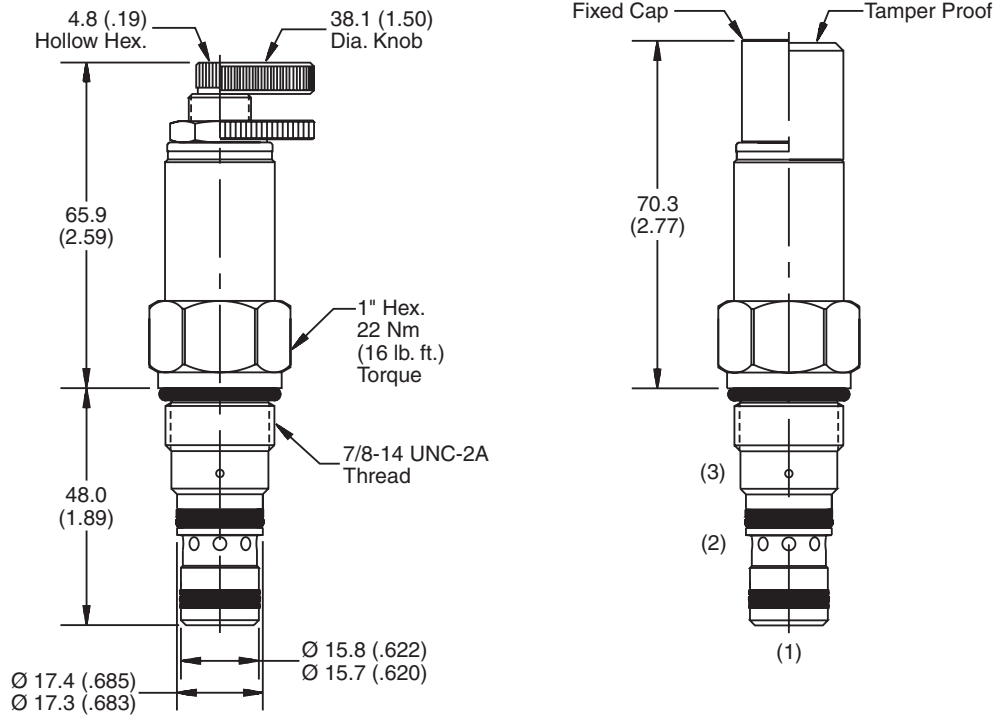

Ordering Information

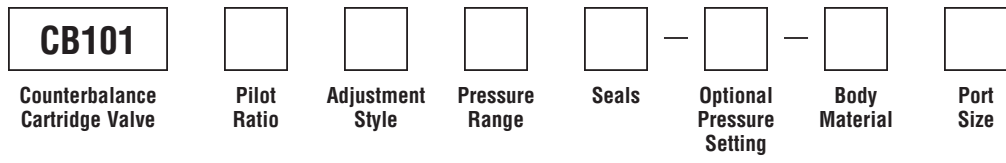

Code	Pilot Ratio
A	3:1
B	4.5:1
C	7:1

Code	Pressure Range
10	20.7 - 90 Bar (300 - 1300 PSI) Standard Setting: 69 Bar (1000 PSI) @ 11.3 LPM (3 GPM)
20	69 - 172.4 Bar (1000 - 2500 PSI) Standard Setting: 138 Bar (2000 PSI) @ 11.3 LPM (3 GPM)
30	166 - 350 Bar (2400 - 5000 PSI) Standard Setting: 210 Bar (3000 PSI) @ 11.3 LPM (3 GPM)

Code	Seals / Kit No.
Omit	Nitrile / (SK10-3N)
V	Fluorocarbon / (SK10-3V)

Code	Body Material
Omit	Steel
A	Aluminum

Code	Adjustment Style/Kit No.
F	Fixed style, preset at factory.
K	Knob Adjust (717784-10)
S	Screw Adjust
T	Tamper Resistant Cap (717785)

Optional Pressure Setting
Pressure \pm 10 i.e. 235 = 2350 PSI Setting Range: 300 to 5000 PSI All settings at 11.3 LPM (3 GPM)

Code	Port Size	Body Part No.
Omit	Cartridge Only	
6T	SAE-6	(B10-3-*6T)
8T	SAE-8	(B10-3-*8T)
6B	3/8" BSPG	(B10-3-6B)†
8B	1/2" BSPG	(B10-3-*8B)

* Body is available in steel or aluminum.
 † Steel body only.



- CV
Check Valves
- SH
Shuttle Valves
- LM
Load/Motor Controls
- FC
Flow Controls
- PC
Pressure Controls
- LE
Logic Elements
- DC
Directional Controls
- MV
Manual Valves
- SV
Solenoid Valves
- PV
Proportional Valves
- CE
Coils & Electronics
- BC
Bodies & Cavities
- TD
Technical Data

- CV** Check Valves
- SH** Shuttle Valves
- LM** Load/Motor Controls
- FC** Flow Controls
- PC** Pressure Controls
- LE** Logic Elements
- DC** Directional Controls
- MV** Manual Valves
- SV** Solenoid Valves
- PV** Proportional Valves
- CE** Coils & Electronics
- BC** Bodies & Cavities
- TD** Technical Data

General Description

Threaded Cartridge Style Counterbalance Valve. For additional information see Technical Tips on pages LM1-LM4.

Features

- Conical Poppet design provides longer metering stroke for stable operation
- Hardened seat provides reliable load holding
- External vent option available for high back pressure applications
- Tamper resistant cap for added safety and security
- Various pilot ratios available for application flexibility
- Unique cavity prevents other valves from being “accidentally” installed
- All external parts zinc plated

Specifications

Rated Flow	37.5 LPM (10 GPM)
Maximum Inlet Pressure	350 Bar (5000 PSI)
Leakage at 150 SSU (32 cSt)	5 drops/min. (.33 cc/min.) @ 80% of thermal crack pressure
Cartridge Material	All parts steel. All operating parts hardened steel.
Operating Temp. Range/Seals	-40°C to +93.3°C (Nitrile) (-40°F to +200°F) -31.7°C to +121.1°C (Fluorocarbon) (-25°F to +250°F)
Fluid Compatibility/Viscosity	Mineral-based or synthetic with lubricating properties at viscosities of 45 to 2000 SSU (6 to 420 cSt)
Filtration	ISO Code 16/13, SAE Class 4 or better
Approx. Weight	.38 kg (.88 lbs.)
Cavity	CDD-1010 (See BC Section for more details)
Form Tool	FR-500

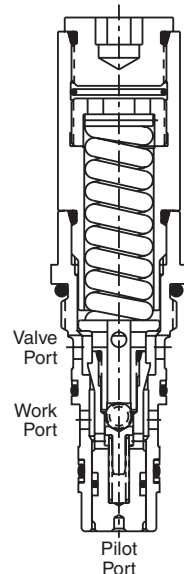
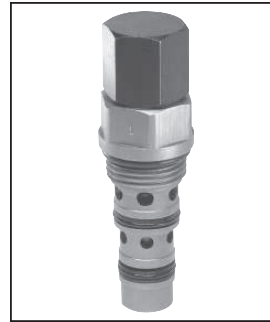

MHC-010-S*S* Non-Vented Counterbalance Adjustable

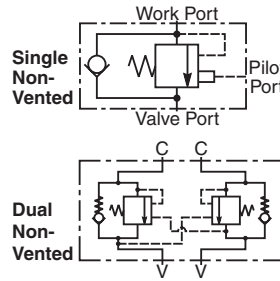

Construction

MHC-010-V*S* Vented Counterbalance Adjustable

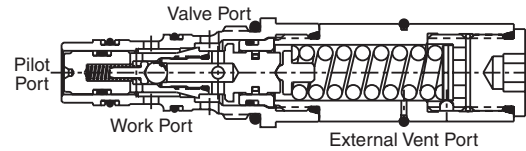

MHC-010-S*N* Non-Vented Counterbalance Non-Adjustable

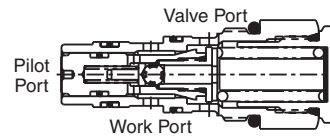

MHC-010-V*N* Vented Counterbalance Non-Adjustable

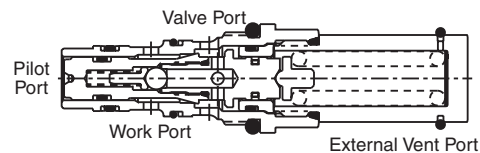

Performance Curve

Flow vs. Pressure Drop (Through cartridge only)

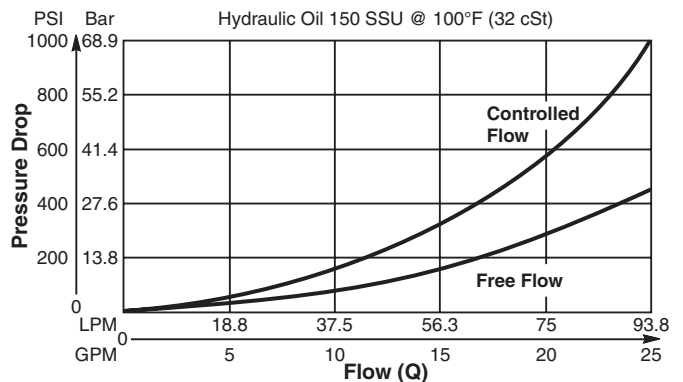

Dimensions Millimeters (Inches)

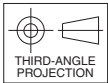
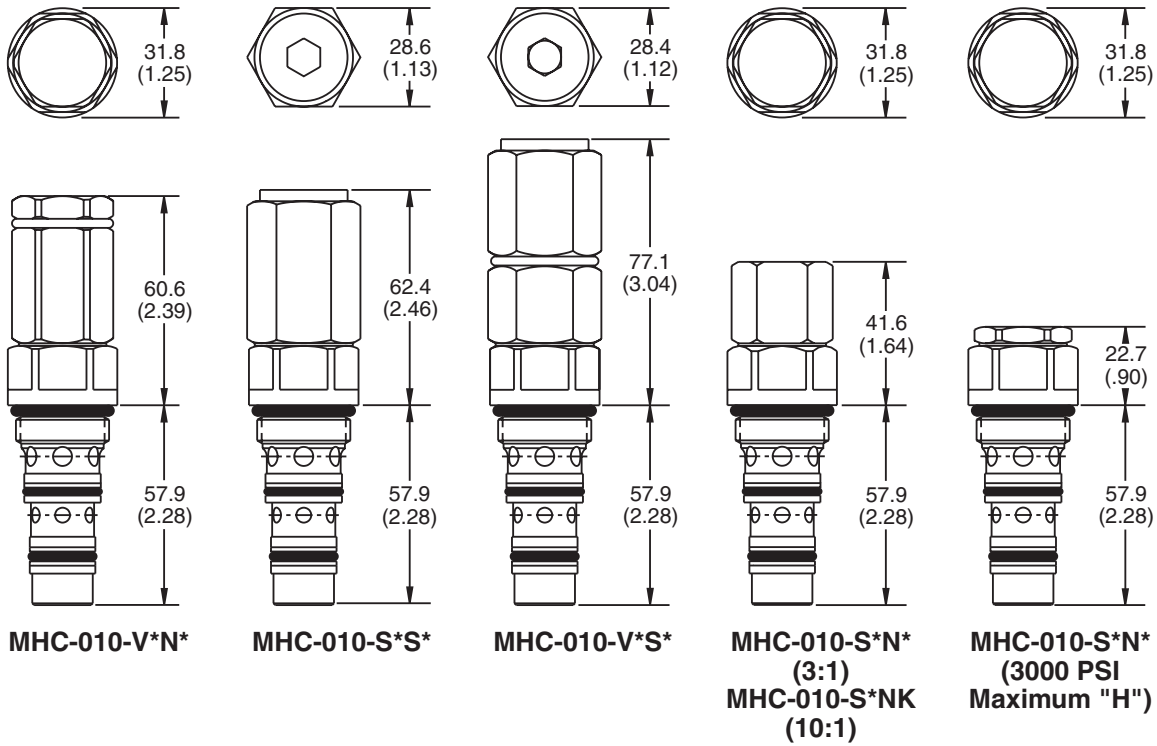

Torque Values
 68-75 Nm (50-55 lb. ft.)
Typical for all

Ordering Information

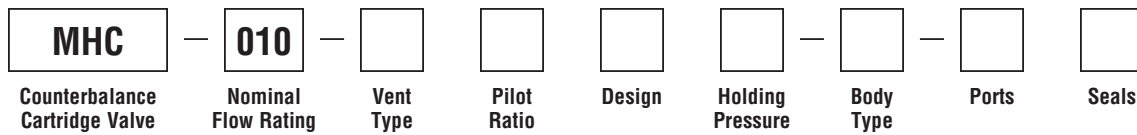

Code	Nominal Flow Rating
010	37.5 LPM (10 GPM)

Code	Vent Type
S	Standard (non-vented)
V	Vented

Code	Pilot Ratio
A	Equal Area (1:1)
B	4:1
F	7:1 (Standard)
J	10:1

Code	Design
S	Standard (adjustable)
N	Shimmed (non-adjustable)

Code	Holding Pressure
C	Equal Area
D	34.5 Bar (500 PSI) Crack
E	69 Bar (1000 PSI) Shim adjustable version only
F	105 Bar (1500 PSI)
G	140 Bar (2000 PSI)
H	170 Bar (2500 PSI)
K	210 Bar (3000 PSI) Standard version
	350 Bar (5000 PSI) 7:1 and 10:1 only Shim version only

Code	Body Type	Part Number
Omit	No Body	
A	Single	MHC-010-A-53
D	Dual	MHC-010-D-53

Code	Ports
00	No Ports
52	SAE-8 through port
53	SAE-10 through port

Code	Seals / Kits
B	Nitrile / 711922
F	Fluorocarbon / 711825

Technical Information

- CV Check Valves
- SH Shuttle Valves
- LM Load/Motor Controls
- FC Flow Controls
- PC Pressure Controls
- LE Logic Elements
- DC Directional Controls
- MV Manual Valves
- SV Solenoid Valves
- PV Proportional Valves
- CE Coils & Electronics
- BC Bodies & Cavities
- TD Technical Data

General Description

Threaded Cartridge Style Counterbalance Valve. For additional information see Technical Tips on pages LM1-LM5.

Features

- Conical Poppet design provides longer metering stroke for stable operation
- Hardened seat provides reliable load holding
- External vent option available for high back pressure applications
- Tamper resistant cap for added safety and security
- Various pilot ratios available for application flexibility
- Unique cavity prevents other valves from being “accidentally” installed
- All external parts zinc plated

Specifications

Rated Flow	93.75 LPM (25 GPM)
Maximum Inlet Pressure	350 Bar (5000 PSI)
Leakage at 150 SSU (32 cSt)	5 drops/min. (.33 cc/min.) @ 80% of thermal crack pressure
Cartridge Material	All parts steel. All operating parts hardened steel.
Operating Temp. Range/Seals	-40°C to +93.3°C (Nitrile) (-40°F to +200°F) -31.7°C to +121.1°C (Fluorocarbon) (-25°F to +250°F)
Fluid Compatibility/Viscosity	Mineral-based or synthetic with lubricating properties at viscosities of 45 to 2000 SSU (6 to 420 cSt)
Filtration	ISO Code 16/13, SAE Class 4 or better
Approx. Weight	.44 kg (1.0 lbs.)
Cavity	CDD-1036 (See BC Section for more details)
Form Tool	FR-501

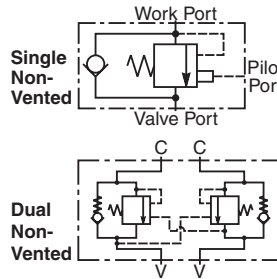
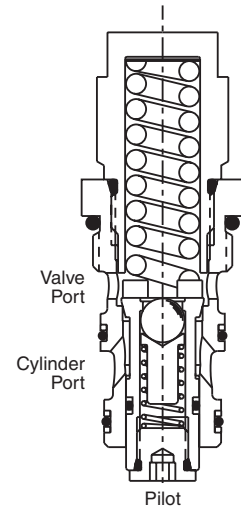
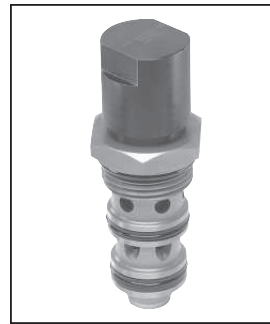

MHC-022-S*N*
Non-Vented Counterbalance
Non-Adjustable

Construction

MHC-022-S*S* Non-Vented Counterbalance Adjustable

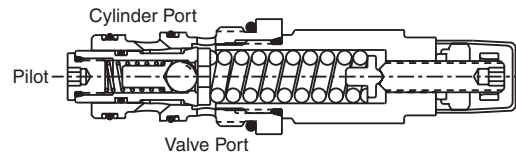

MHC-022-V*N* Vented Counterbalance Non-Adjustable

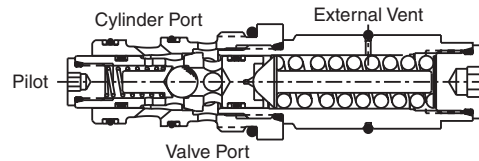

Performance Curve

Flow vs. Pressure Drop (Through cartridge only)

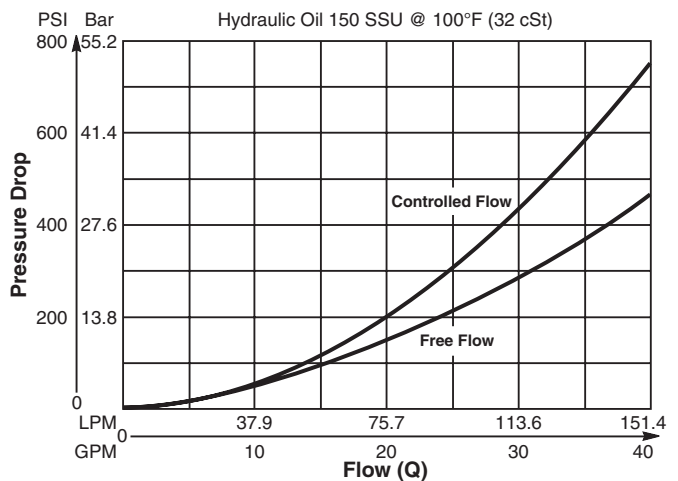

Dimensions Millimeters (Inches)

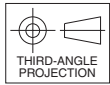
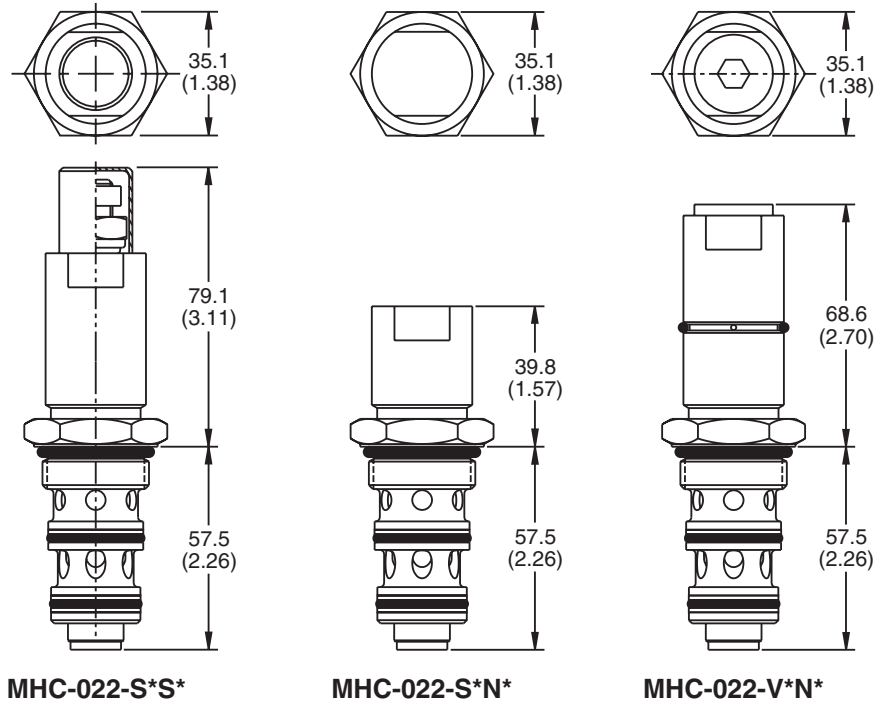

Torque Values
 8-9 Nm (6-7 lb. ft.)
Typical for all

Ordering Information

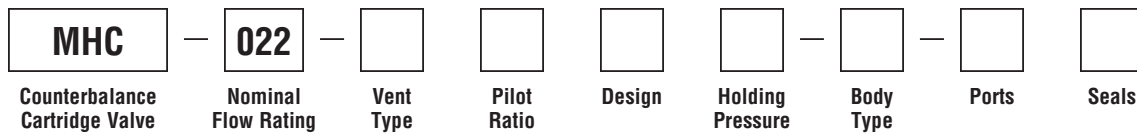

Code	Nominal Flow Rating
022	93.75 LPM (25 GPM)

Code	Pilot Ratio
A	Equal Area (1:1)
C	5:1 (Standard)
J	10:1

Code	Holding Pressure
C	Equal Area 34.5 Bar (500 PSI) Crack
E	103.4 Bar (1500 PSI) Shim adjustable version only
H	210 Bar (3000 PSI) Standard version
J	240 Bar (3500 PSI)
K	350 Bar (5000 PSI) 10:1 only

Code	Body Type	Part Number
Omit	No Body	
A	Single	MHC-022-A-53
D	Dual	MHC-022-D-53

Code	Vent Type
S	Standard (non-vented)
V	Vented

Code	Design
S	Standard with tamper resistant cap (adjustable)
N	Shimmed (non-adjustable)

Code	Ports
00	No Ports
53	SAE-10 through port

Code	Seals / Kits
B	Nitrile / 712226
F	Fluorocarbon / TBD

- CV** Check Valves
- SH** Shuttle Valves
- LM** Load/Motor Controls
- FC** Flow Controls
- PC** Pressure Controls
- LE** Logic Elements
- DC** Directional Controls
- MV** Manual Valves
- SV** Solenoid Valves
- PV** Proportional Valves
- CE** Coils & Electronics
- BC** Bodies & Cavities
- TD** Technical Data

General Description

Body Style Counterbalance Valve. For additional information see Technical Tips on pages LM1-LM4.

Features

- Conical Poppet design provides longer metering stroke for stable operation
- Hardened seat provides reliable load holding
- External vent option available for high back pressure applications
- Tamper resistant cap for added safety and security
- Various pilot ratios available for application flexibility

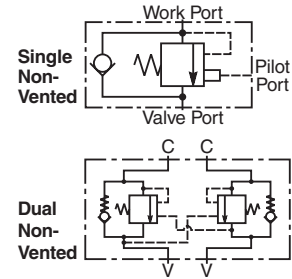
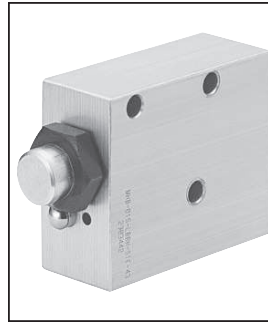

Specifications

Rated Flow	46.25 LPM (15 GPM)
Maximum Inlet Pressure	210 Bar (3000 PSI)
Leakage at 150 SSU (32 cSt)	5 drops/min. (.33 cc/min.) @ 80% of thermal crack pressure
Valve Material	All parts steel. All operating parts hardened steel.
Body Material	Aluminum
Operating Temp. Range/Seals	-31.7°C to +121.1°C (Fluorocarbon) (-25°F to +250°F)
Fluid Compatibility/Viscosity	Mineral-based or synthetic with lubricating properties at viscosities of 45 to 2000 SSU (6 to 420 cSt)
Filtration	ISO Code 16/13, SAE Class 4 or better
Approx. Weight	Single 0.68 kg (1.5 lbs.) Double 1.36 kg (3.0 lbs.)

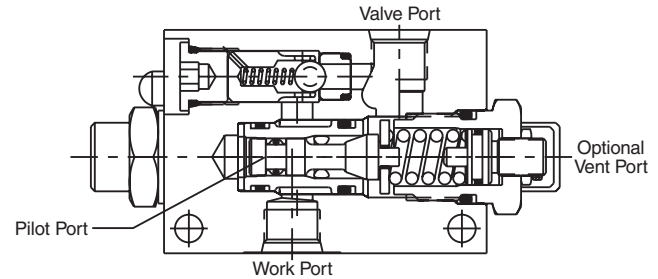

Performance Curve

Flow vs. Pressure Drop (Through cartridge only)

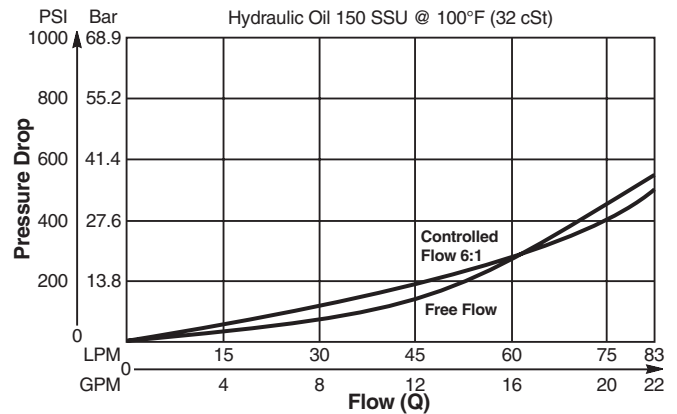

Ordering Information

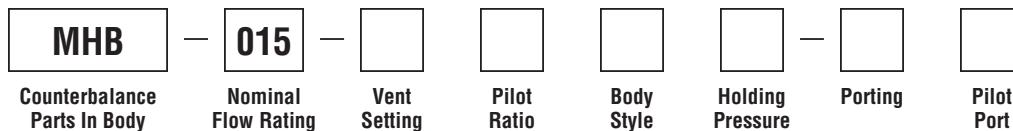

Code	Nominal Flow Rating
015	46.3 LPM (15 GPM)

Code	Pilot Ratio
*A	1:1 Equal Area
B	3:1
E	6:1
J	10:1

Code / Body Style	
A / Single Inline	D / Double Inline
B / Single Gasket	E / Double Gasket

Code	Porting
51	SAE-6
52	SAE-8 (Gasket mount only)

Code	Vent Setting
L	Non-Vented
W	Vent

**Equal Area does not have a thermal relief*

Code	Holding Pressure
*C	17.2 to 34.5 Bar (250 to 500 PSI) 1:1 Pilot Crack Pressure
E	34.5 to 103.4 Bar (500 to 1500 PSI)
H	105 to 210 Bar (1500 to 3000 PSI)

**Equal Area does not have a thermal relief*

Code	Pilot Port
N	Internal Pilot (Dual valve only)
E	SAE-6 (Code 51 & 52 bodies only)

Seal Kits:

Single 711708
Double 711709

Dimensions

*Inch equivalents for millimeter dimensions are shown in (**)

Series MHB-015-L*A* Single Counterbalance, Non-Vented, In-line Mount

Series MHB-015-W*A* Single Counterbalance, Vented, In-line Mount

MHB-015-L*A* Non-Vented

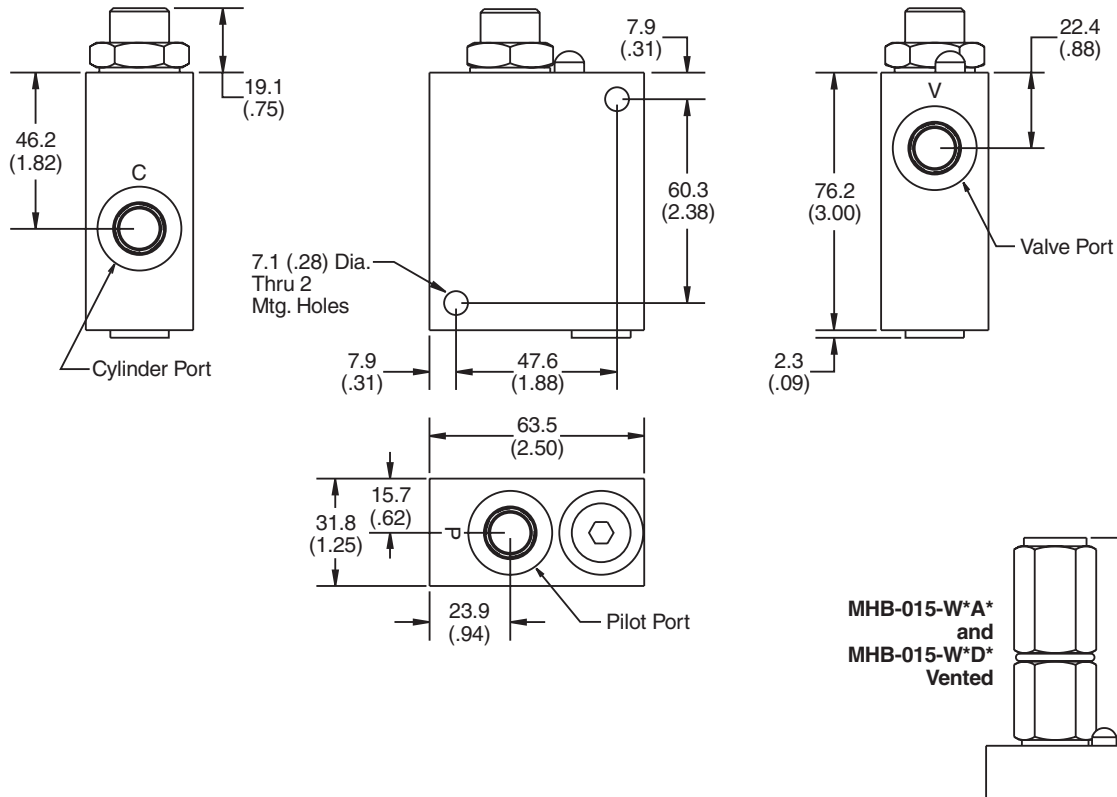

Series MHB-015-L*D* Dual Counterbalance, Non-Vented, In-line Mount

Series MHB-015-W*D* Dual Counterbalance, Vented, In-line Mount

MHB-015-L*D* Non-Vented

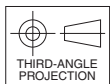
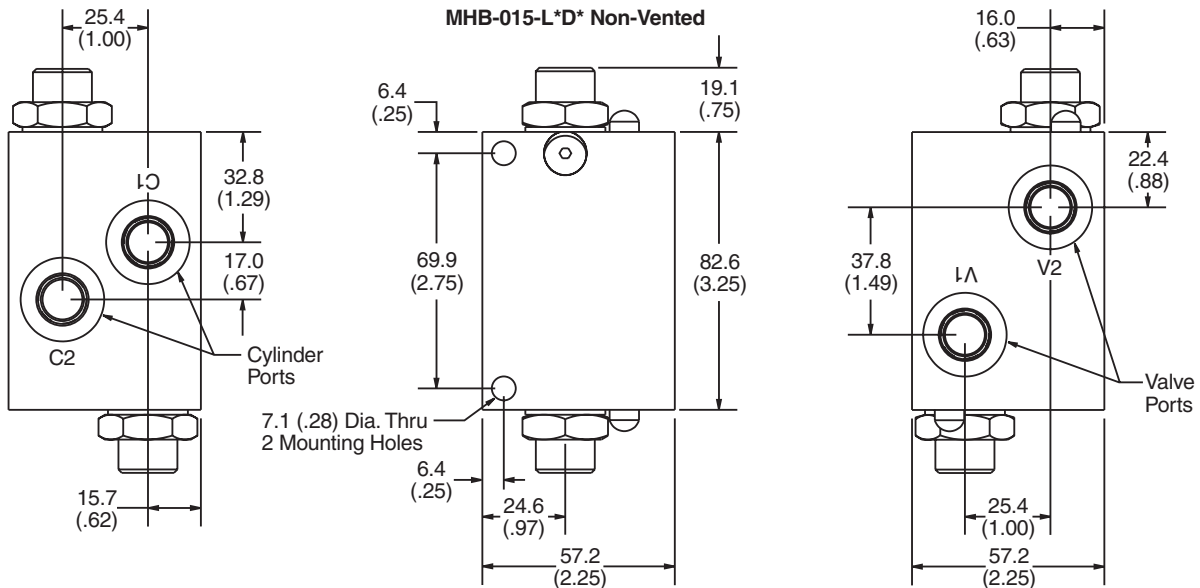

CV
Check Valves
SH
Shuttle Valves
LM
Load/Motor Controls
FC
Flow Controls
PC
Pressure Controls
LE
Logic Elements
DC
Directional Controls
MV
Manual Valves
SV
Solenoid Valves
PV
Proportional Valves
CE
Coils & Electronics
BC
Bodies & Cavities
TD
Technical Data

Dimensions

*Inch equivalents for millimeter dimensions are shown in (**)

Series MHB-015-L*B* Single Counterbalance, Non-Vented, Gasket Mount

Series MHB-015-W*B* Single Counterbalance, Vented, Gasket Mount

MHB-015-L*B* Non-Vented

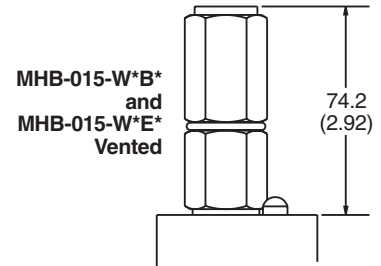
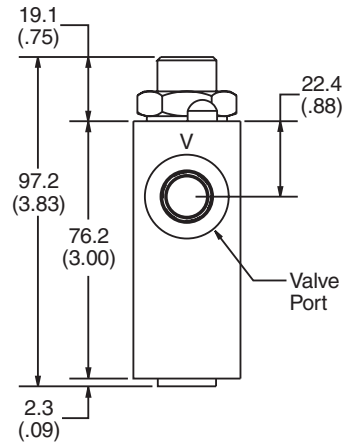
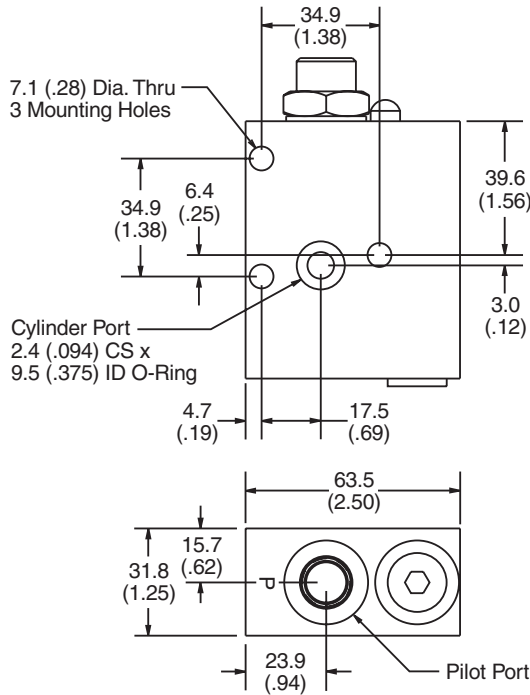

Series MHB-015-L*E* Dual Counterbalance, Non-Vented, Gasket Mount

Series MHB-015-W*E* Dual Counterbalance, Vented, Gasket Mount

MHB-015-L*E* Non-Vented

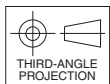
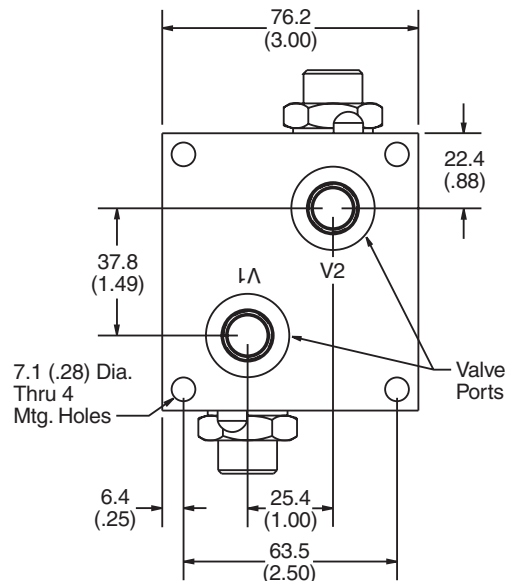
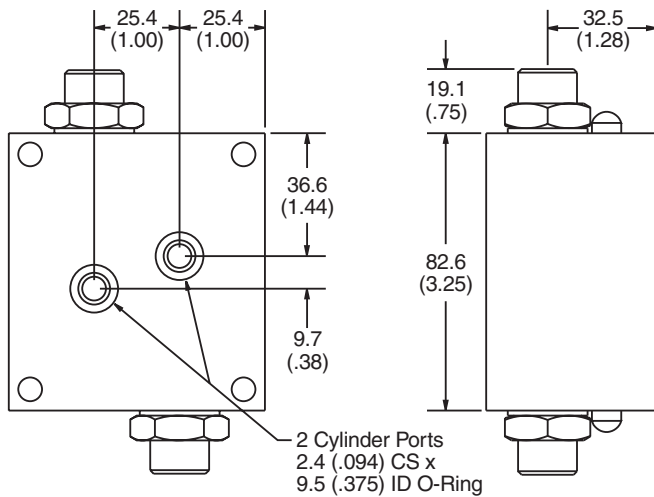

- CV** Check Valves
- SH** Shuttle Valves
- LM** Load/Motor Controls
- FC** Flow Controls
- PC** Pressure Controls
- LE** Logic Elements
- DC** Directional Controls
- MV** Manual Valves
- SV** Solenoid Valves
- PV** Proportional Valves
- CE** Coils & Electronics
- BC** Bodies & Cavities
- TD** Technical Data

General Description

Body Style Counterbalance Valve. For additional information see Technical Tips on pages LM1-LM4.

Features

- Conical Poppet design provides longer metering stroke for stable operation
- Hardened seat provides reliable load holding
- External vent option available for high back pressure applications
- Tamper resistant cap for added safety and security
- Various pilot ratios available for application flexibility

Specifications

Rated Flow	112.5 LPM (30 GPM)
Maximum Inlet Pressure	210 Bar (3000 PSI)
Leakage at 150 SSU (32 cSt)	5 drops/min. (.33 cc/min.) @ 80% of thermal crack pressure
Valve Material	All parts steel. All operating parts hardened steel.
Body Material	Aluminum
Operating Temp. Range/Seals	-31.7°C to +121.1°C (Fluorocarbon) (-25°F to +250°F)
Fluid Compatibility/Viscosity	Mineral-based or synthetic with lubricating properties at viscosities of 45 to 2000 SSU (6 to 420 cSt)
Filtration	ISO Code 16/13, SAE Class 4 or better
Approx. Weight	Single 1.13 kg (2.5 lbs.) Double 2.05 kg (4.5 lbs.)

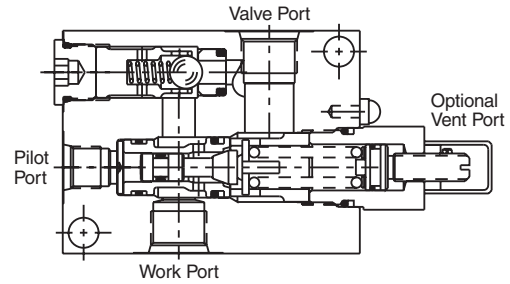
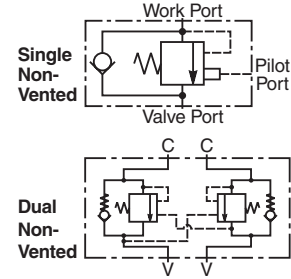
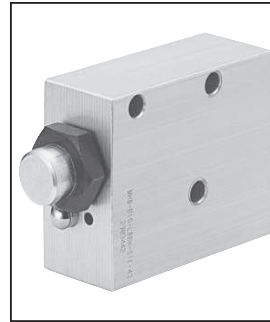

Performance Curve
Flow vs. Pressure Drop (Through cartridge only)

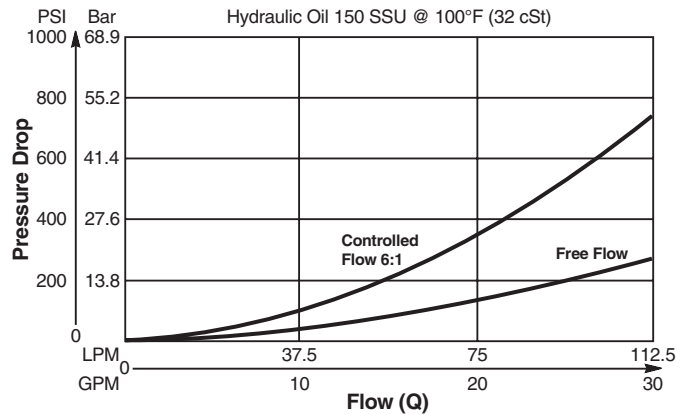

Ordering Information

MHB —
 030 —

Counterbalance Parts In Body **Nominal Flow Rating** **Vent Setting** **Pilot Ratio** **Body Style** **Holding Pressure** **Porting** **Pilot Port**

Code	Nominal Flow Rating
030	112.5 LPM (30 GPM)

Code	Pilot Ratio
*A	1:1 Equal Area
B	3:1
E	6:1
J	10:1

Code / Body Style
A / Single Inline
B / Single Gasket
D / Double Inline

Code	Porting
52	SAE-8

Code	Pilot Port
N	Internal Pilot (Dual valve only)
E	SAE-6 (Code 52 & 53 bodies only)

Code	Vent Setting
L	Non-Vented
W	Vent

Code	Holding Pressure
*C	17.2 to 34.5 Bar (250 to 500 PSI) 1:1 Pilot Crack Pressure
E	34.5 to 103.4 Bar (500 to 1500 PSI)
H	105 to 210 Bar (1500 to 3000 PSI)

**Equal Area does not have a thermal relief*

Seal Kits:
Single 711654
Double 711655

- CV** Check Valves
- SH** Shuttle Valves
- LM** Load/Motor Controls
- FC** Flow Controls
- PC** Pressure Controls
- LE** Logic Elements
- DC** Directional Controls
- MV** Manual Valves
- SV** Solenoid Valves
- PV** Proportional Valves
- CE** Coils & Electronics
- BC** Bodies & Cavities
- TD** Technical Data

Dimensions

*Inch equivalents for millimeter dimensions are shown in (**)

Series MHB-030-L*A* Single Counterbalance, Non-Vented, In-line Mount

Series MHB-030-W*A* Single Counterbalance, Vented, In-line Mount

MHB-030-L*A* Non-Vented

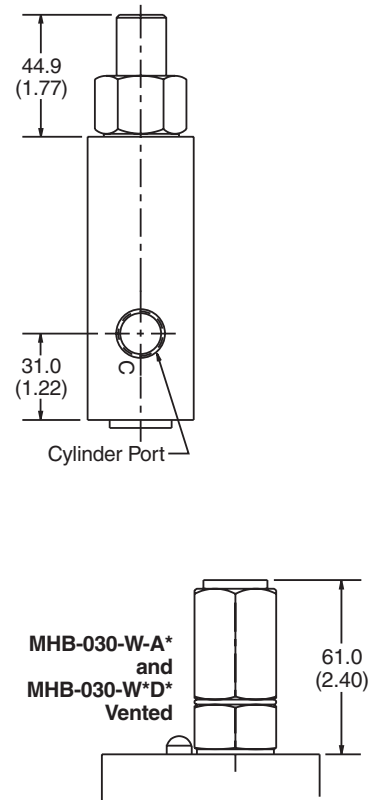
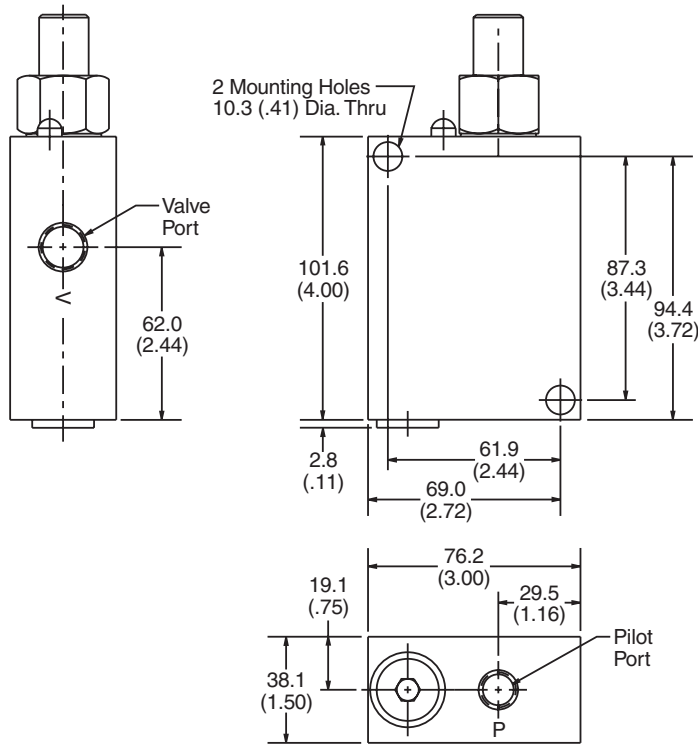

Series MHB-030-L*D* Dual Counterbalance, Non-Vented, In-line Mount

Series MHB-030-W*D* Dual Counterbalance, Vented, In-line Mount

MHB-030-L*D* Non-Vented

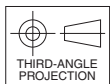
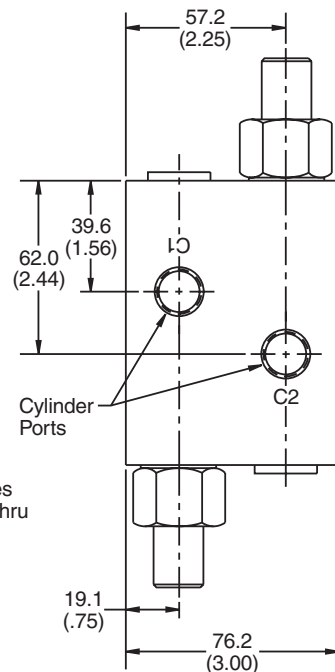
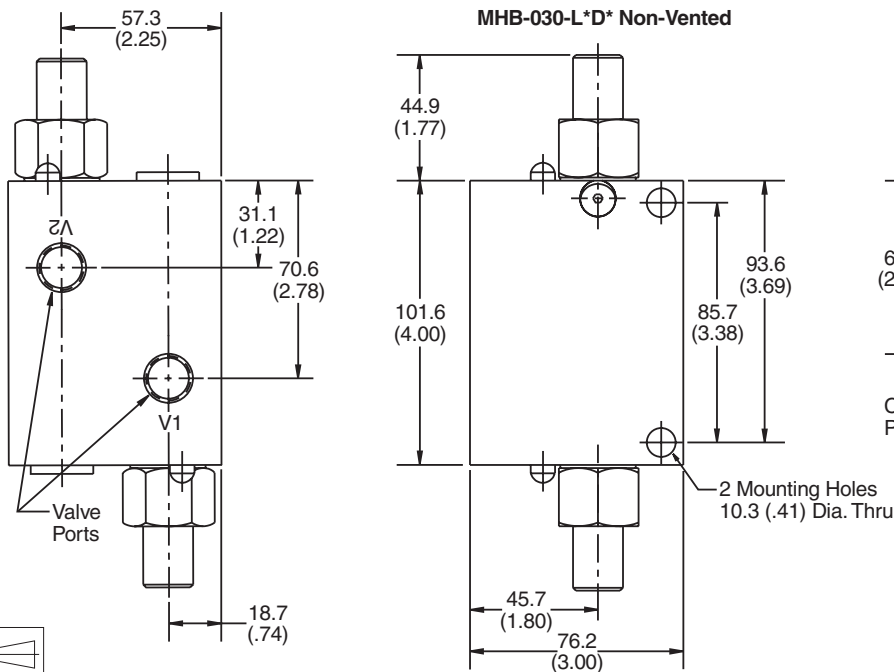

- CV Check Valves
- SH Shuttle Valves
- LM Load/Motor Controls
- FC Flow Controls
- PC Pressure Controls
- LE Logic Elements
- DC Directional Controls
- MV Manual Valves
- SV Solenoid Valves
- PV Proportional Valves
- CE Coils & Electronics
- BC Bodies & Cavities
- TD Technical Data

*Inch equivalents for millimeter dimensions are shown in (**)

Series MHB-030-L*B* Single Counterbalance, Non-Vented, Gasket Mount

Series MHB-030-W*B* Single Counterbalance, Vented, Gasket Mount

MHB-030-L*B* Non-Vented

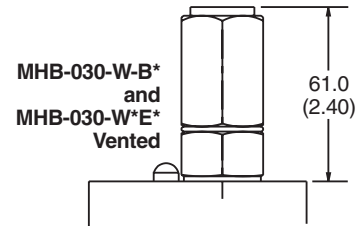
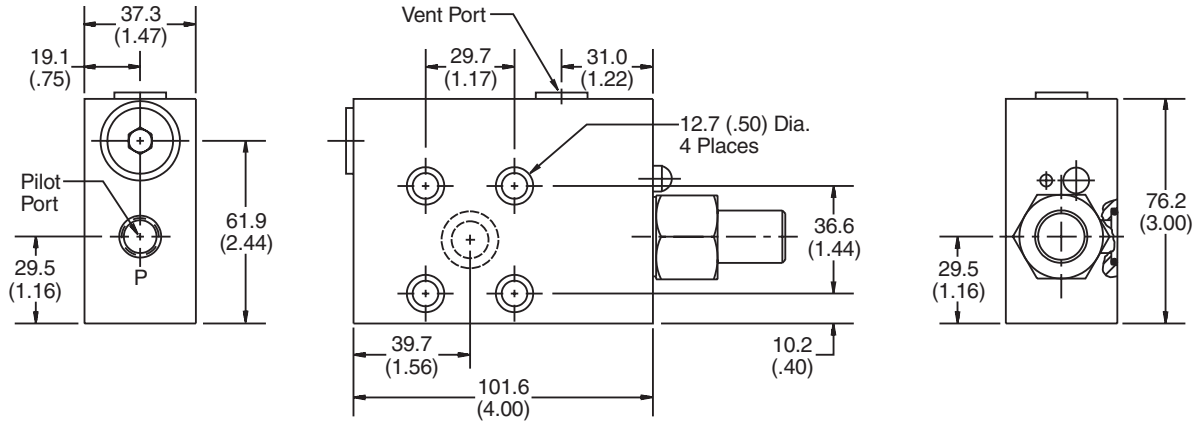

Series MHB-030-L*E* Dual Counterbalance, Non-Vented, Gasket Mount

Series MHB-030-W*E* Dual Counterbalance, Vented, Gasket Mount

MHB-030-L*E* Non-Vented

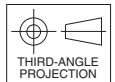
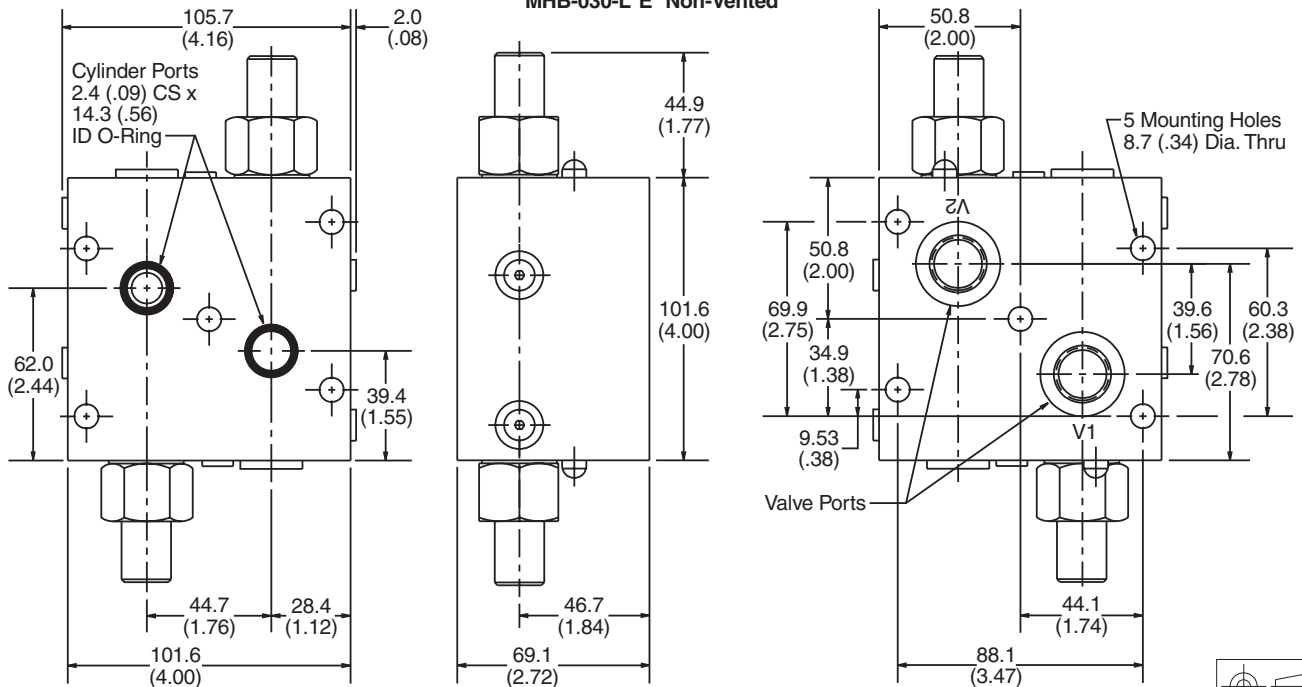

CV
Check Valves
SH
Shuttle Valves
LM
Load/Motor Controls
FC
Flow Controls
PC
Pressure Controls
LE
Logic Elements
DC
Directional Controls
MV
Manual Valves
SV
Solenoid Valves
PV
Proportional Valves
CE
Coils & Electronics
BC
Bodies & Cavities
TD
Technical Data

Technical Information

- CV Check Valves
- SH Shuttle Valves
- LM Load/Motor Controls
- FC Flow Controls
- PC Pressure Controls
- LE Logic Elements
- DC Directional Controls
- MV Manual Valves
- SV Solenoid Valves
- PV Proportional Valves
- CE Coils & Electronics
- BC Bodies & Cavities
- TD Technical Data

General Description

Threaded Cartridge Style Counterbalance Valve. Pilot assisted, designed for motion control applications. For additional information see Technical Tips on pages LM1-LM4.

Features

- Poppet construction for minimal leakage
- Incorporates direct acting relief valve for overload protection
- Includes reverse check valve within body, saving space and minimizing installation cost
- Can be directly mounted into cylinder eliminating requirement for manifold block
- Fully sealed pilot for high efficiency and accurate pilot ratio
- Two pilot ratios available, 4.5:1 for cylinders and 8:1 for motor control
- Adjustable and tamper resistant versions available
- Preset version is tamper resistant and compact
- All external parts zinc plated

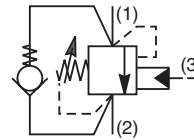
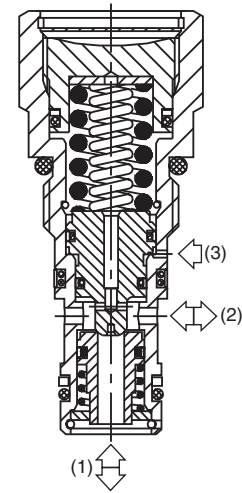

Specifications

Rated Flow	E2A020 14 LPM (3.7 GPM) E2B020 20 LPM (5.3 GPM)
Pressure	50 - 420 Bar (725 - 6000 PSI)
Sensitivity: Pressure/Turn	E2A020 113 Bar (1640 PSI) E2B020 84 Bar (1220 PSI)
Pilot Ratio	E2A020 - 8 : 1 E2B020 - 4.5 : 1
Cartridge Material	All parts steel. All operating parts hardened steel.
Operating Temp. Range/Seals	-40°C to +93.3°C (Nitrile) (-40°F to +200°F) -31.7°C to +121.1°C (Fluorocarbon) (-25°F to +250°F)
Fluid Compatibility/ Viscosity	Mineral-based or synthetic with lubricating properties at viscosities of 45 to 2000 SSU (6 to 420 cSt)
Filtration	ISO Code 16/13, SAE Class 4 or better
Approx. Weight	0.08 kg (0.17 lbs.)
Cavity	53-1 (See BC Section for more details)

Performance Curves

Relief & Pilot Performance 1 to 2

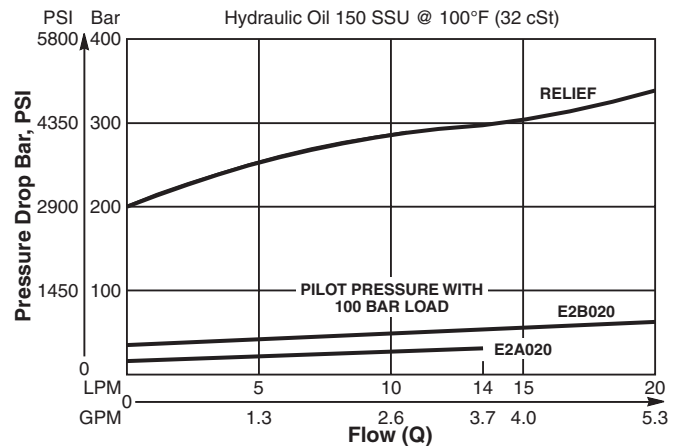

Pressure Drop vs Flow

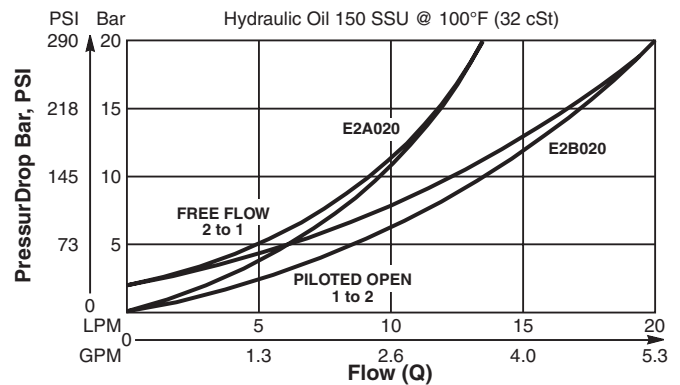

Dimensions Millimeters (Inches)

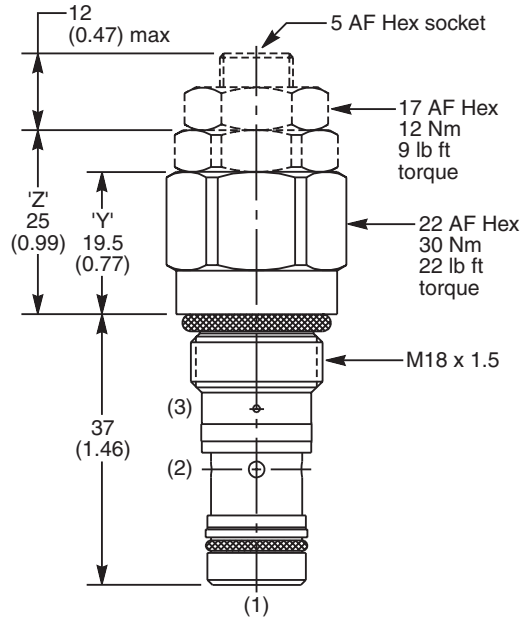

Ordering Information

E2		020			
Load Control Valve	Pilot Ratio	Adjustment Style	Cracking Pressure	Seals	

Code	Pilot Ratio
A	8 : 1
B	4.5 : 1

Code	Cracking Pressure
	Omit for no setting (Standard)* Specify setting if required

**Standard valve is set to crack at 215 Bar (3120 PSI). Valve to be set to 1.3 times maximum load induced pressure.*

Code	Adjustment Style / Kit No.
Z	Screw Adjust
T	Tamper Resistant (TC1125)
Y	Preset (Standard)

Code	Seals / Kit No.
N	Nitrile, Buna-N (Std.) / (SK30087N-1)
V	Fluorocarbon / (SK30087V-1)

Order Bodies Separately

LB10		
Line Body	Porting	Body Material

Code	Porting
310	3/8" BSP (main) 1/4" BSP (aux)
318	3/8" SAE (main) 1/4" SAE (aux)
312	3/8" BSP Dual Cavity
319	3/8" SAE Dual Cavity

Code	Body Material
A	Aluminum
S	Steel

- CV**
Check Valves
- SH**
Shuttle Valves
- LM**
Load/Motor Controls
- FC**
Flow Controls
- PC**
Pressure Controls
- LE**
Logic Elements
- DC**
Directional Controls
- MV**
Manual Valves
- SV**
Solenoid Valves
- PV**
Proportional Valves
- CE**
Coils & Electronics
- BC**
Bodies & Cavities
- TD**
Technical Data

Technical Information

- CV Check Valves
- SH Shuttle Valves
- LM Load/Motor Controls
- FC Flow Controls
- PC Pressure Controls
- LE Logic Elements
- DC Directional Controls
- MV Manual Valves
- SV Solenoid Valves
- PV Proportional Valves
- CE Coils & Electronics
- BC Bodies & Cavities
- TD Technical Data

General Description

Threaded Cartridge Style Counterbalance Valve. Pilot assisted, designed for motion control applications. For additional information see Technical Tips on pages LM1-LM4.

Features

- Poppet construction for minimal leakage
- Incorporates direct acting relief valve for overload protection
- Includes reverse check valve within body, saving space and minimizing installation cost
- Excellent control and very good stability
- Three pilot ratios available, 1.75:1 and 3:1 for cylinders and 8:1 for motor control
- Hardened working parts for maximum durability
- Adjustable, preset and tamper resistant versions available
- Preset version is tamper resistant and compact
- All external parts zinc plated

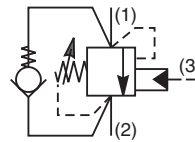
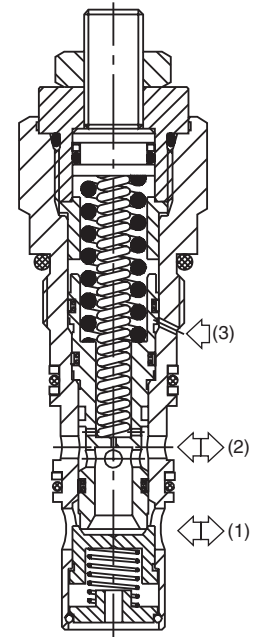
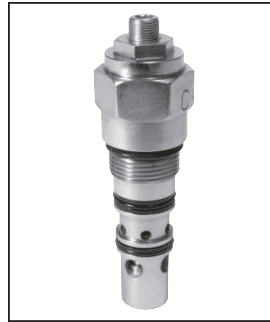

Specifications

Rated Flow	60 LPM (15.9 GPM)
Pressure	50 - 350 Bar (725 - 5000 PSI)
Sensitivity: Pressure/Turn	99 Bar (1435 PSI)
Pilot Ratio	E2A040 - 8 : 1 E2B040 - 3 : 1 E2H040 - 1.75 : 1
Cartridge Material	All parts steel. All operating parts hardened steel.
Operating Temp. Range/Seals	-40°C to +93.3°C (Nitrile) (-40°F to +200°F) -31.7°C to +121.1°C (Fluorocarbon) (-25°F to +250°F)
Fluid Compatibility/ Viscosity	Mineral-based or synthetic with lubricating properties at viscosities of 45 to 2000 SSU (6 to 420 cSt)
Filtration	ISO Code 16/13, SAE Class 4 or better
Approx. Weight	0.27 kg (0.60 lbs.)
Cavity	68-1 (See BC Section for more details)

Performance Curves

Relief & Pilot Performance 1 to 2

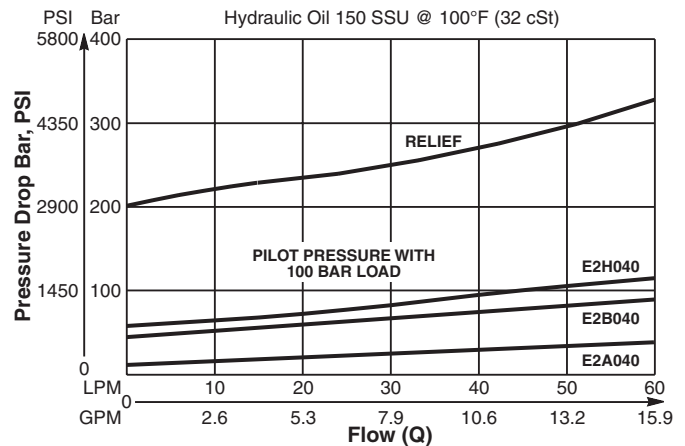

Pressure Drop vs Flow

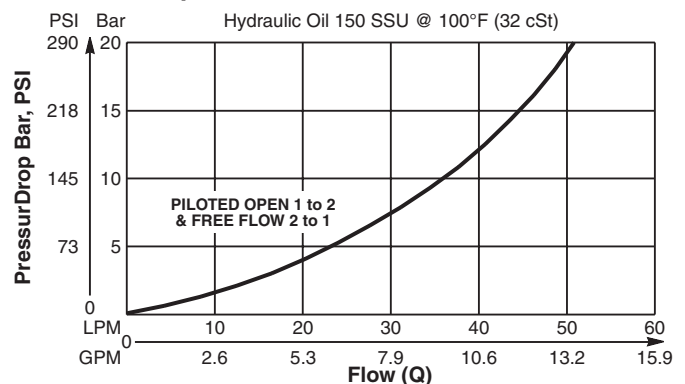

Dimensions Millimeters (Inches)

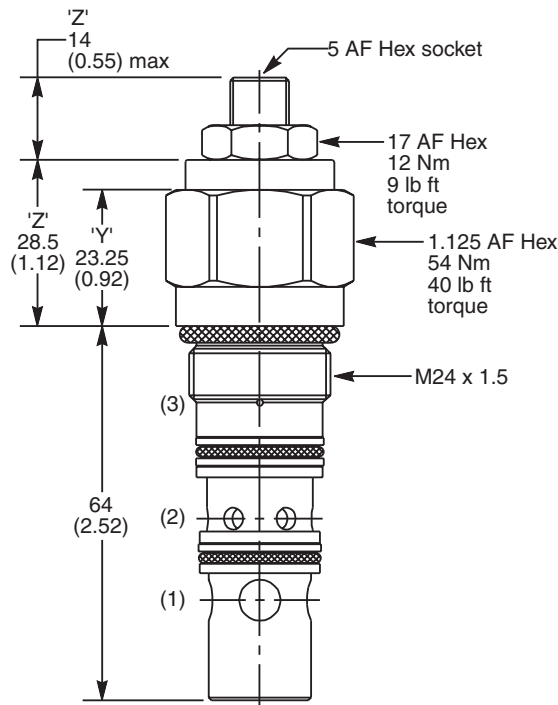

Ordering Information

E2		040				MK3
Load Control Valve	Pilot Ratio	Adjustment Style	Cracking Pressure	Seals		

Code	Pilot Ratio
A	8 : 1
B	3 : 1
H	1.75 : 1

Code	Cracking Pressure
	Omit for no setting (Standard)* Specify setting if required Y: Setting must be specified

**Standard valve is set to crack at 215 Bar (3120 PSI). Valve to be set to 1.3 times maximum load induced pressure.*

Code	Adjustment Style / Kit No.
Z	Screw Adjust (Standard)
T	Tamper Resistant (TC1125)
Y	Non Adjustable Preset

Code	Seals / Kit No.
N	Nitrile, Buna-N (Std.) / (SK30059N-1)
V	Fluorocarbon / (SK30059V-1)

Order Bodies Separately

LB10		
Line Body	Porting	Body Material

Code	Porting
251	1/2" BSP (main) 1/4" BSP (aux)
253	1/2" SAE (main) 1/4" SAE (aux)
259	1/2" BSP Dual Cavity
261	1/2" SAE Dual Cavity

Code	Body Material
A	Aluminum
S	Steel

- CV**
Check Valves
- SH**
Shuttle Valves
- LM**
Load/Motor Controls
- FC**
Flow Controls
- PC**
Pressure Controls
- LE**
Logic Elements
- DC**
Directional Controls
- MV**
Manual Valves
- SV**
Solenoid Valves
- PV**
Proportional Valves
- CE**
Coils & Electronics
- BC**
Bodies & Cavities
- TD**
Technical Data

- CV** Check Valves
- SH** Shuttle Valves
- LM** Load/Motor Controls
- FC** Flow Controls
- PC** Pressure Controls
- LE** Logic Elements
- DC** Directional Controls
- MV** Manual Valves
- SV** Solenoid Valves
- PV** Proportional Valves
- CE** Coils & Electronics
- BC** Bodies & Cavities
- TD** Technical Data

General Description

Threaded Cartridge Style Counterbalance Valve. Pilot assisted, designed for motion control applications. For additional information see Technical Tips on pages LM1-LM4.

Features

- Poppet construction for minimal leakage
- Incorporates direct acting relief valve for overload protection
- Includes reverse check valve within body, saving space and minimizing installation cost
- Fully sealed pilot for high efficiency and accurate pilot ratio
- Four pilot ratios available, 1.5:1, 2.3:1, 3:1 and 4.5:1
- Hardened working parts for maximum durability
- All external parts zinc plated

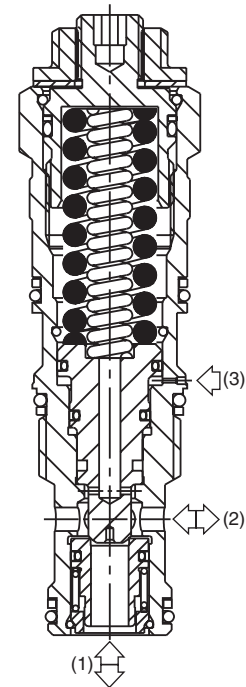
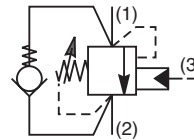
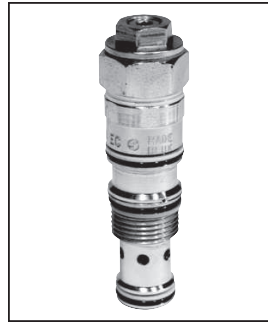

Specifications

Rated Flow	60 LPM (16 GPM)
Pressure	40 - 350 Bar (580 - 5000 PSI)
Sensitivity: Pressure/Turn	104 Bar (1508 PSI)
Pilot Ratio	E2E1 - 1.5 : 1 E2G1 - 2.3 : 1 E2K1 - 3 : 1 E2M1 - 4.5 : 1
Cartridge Material	All parts steel. All operating parts hardened steel.
Operating Temp. Range/Seals	-40°C to +93.3°C (Nitrile) (-40°F to +200°F) -31.7°C to +121.1°C (Fluorocarbon) (-25°F to +250°F)
Fluid Compatibility/ Viscosity	Mineral-based or synthetic with lubricating properties at viscosities of 45 to 2000 SSU (6 to 420 cSt)
Filtration	ISO Code 16/13, SAE Class 4 or better
Approx. Weight	0.17 kg (0.37 lbs.)
Cavity	CAVT11A (See BC Section for more details)

Performance Curves

Relief & Pilot Performance 1 to 2

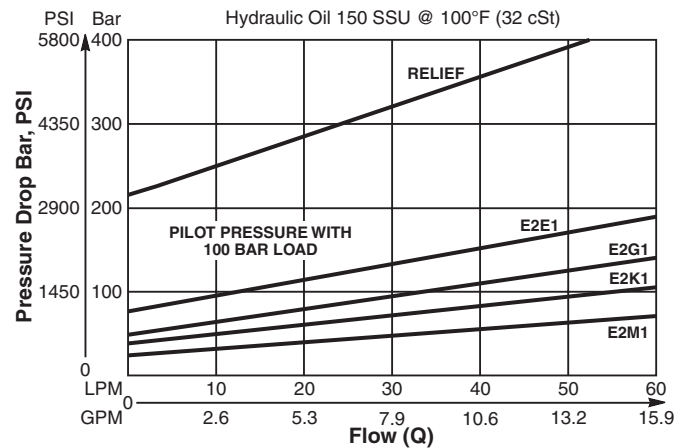

Pressure Drop vs Flow

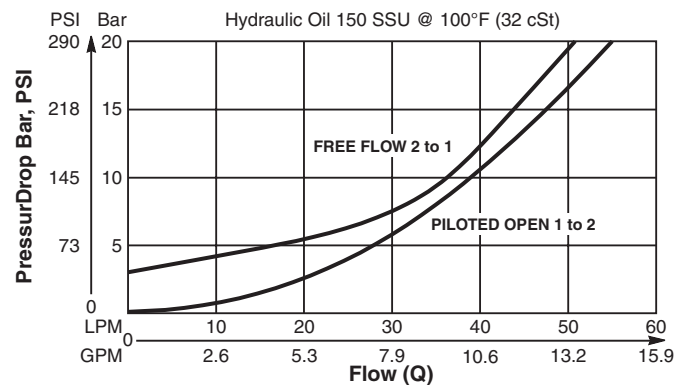

Dimensions Millimeters (Inches)

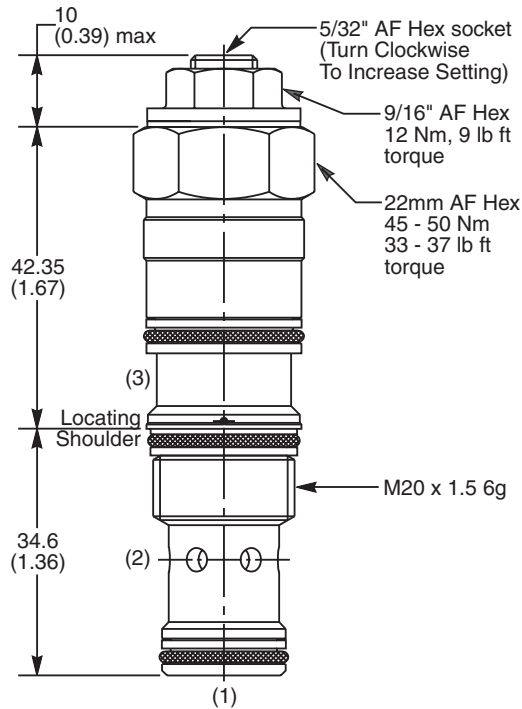

Ordering Information

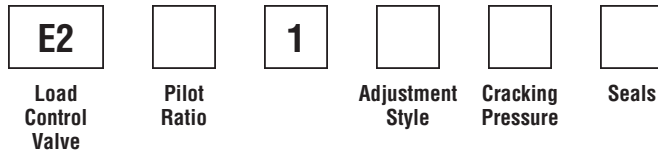

Code	Pilot Ratio
E	1.5 : 1
G	2.3 : 1
K	3 : 1
M	4.5 : 1

Code	Cracking Pressure
	Omit for no setting (Standard)* Specify setting if required

**Standard valve is set to crack at 215 Bar (3120 PSI). Valve to be set to 1.3 times maximum load induced pressure.*

Code	Adjustment Style / Kit No.
Z	Screw Adjust (Standard)
T	Tamper Resistant (TC1131)

Code	Seals / Kit No.
N	Nitrile, Buna-N (Std.) / (SK30700N-1)
V	Fluorocarbon / (SK30700V-1)

Order Bodies Separately



Code	Porting
826	1/2" BSP (main) 1/4" BSP (aux)
825	1/2" SAE (main) 1/4" SAE (aux)
828	1/2" BSP Dual Cavity
827	1/2" SAE Dual Cavity

Code	Body Material
A	Aluminum
S	Steel

- CV** Check Valves
- SH** Shuttle Valves
- LM** Load/Motor Controls
- FC** Flow Controls
- PC** Pressure Controls
- LE** Logic Elements
- DC** Directional Controls
- MV** Manual Valves
- SV** Solenoid Valves
- PV** Proportional Valves
- CE** Coils & Electronics
- BC** Bodies & Cavities
- TD** Technical Data

Technical Information

- CV** Check Valves
- SH** Shuttle Valves
- LM** Load/Motor Controls
- FC** Flow Controls
- PC** Pressure Controls
- LE** Logic Elements
- DC** Directional Controls
- MV** Manual Valves
- SV** Solenoid Valves
- PV** Proportional Valves
- CE** Coils & Electronics
- BC** Bodies & Cavities
- TD** Technical Data

General Description

Threaded Cartridge Style Counterbalance Valve. Semi-Restrictive Ports 2 to 3. Pilot assisted, designed for motion control applications. For additional information see Technical Tips on pages LM1-LM4.

Features

- Poppet construction for minimal leakage
- Incorporates direct acting relief valve for overload protection
- Includes reverse check valve within body, saving space and minimizing installation cost
- Fully sealed pilot for high efficiency and accurate pilot ratio
- Four pilot ratios available, 1.5:1, 2.3:1, 3:1 and 4.5:1
- Hardened working parts for maximum durability
- All external parts zinc plated

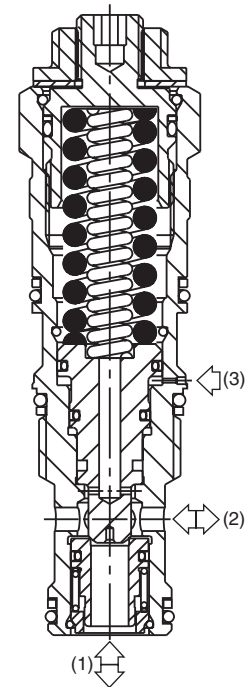
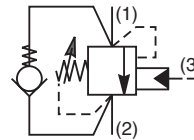
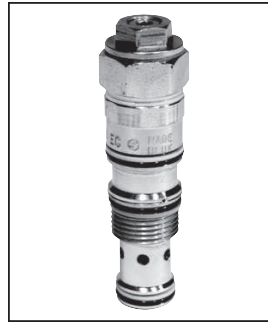

Specifications

Rated Flow	Free flow 60 LPM (16 GPM) Piloted open flow 45 LPM (12 GPM)
Pressure	40 - 350 Bar (580 - 5000 PSI)
Sensitivity: Pressure/Turn	104 Bar (1508 PSI)
Pilot Ratio	E2E1S - 1.5 : 1 E2G1S - 2.3 : 1 E2K1S - 3 : 1 E2M1S - 4.5 : 1
Cartridge Material	All parts steel. All operating parts hardened steel.
Operating Temp. Range/Seals	-40°C to +93.3°C (Nitrile) (-40°F to +200°F) -31.7°C to +121.1°C (Fluorocarbon) (-25°F to +250°F)
Fluid Compatibility/ Viscosity	Mineral-based or synthetic with lubricating properties at viscosities of 45 to 2000 SSU (6 to 420 cSt)
Filtration	ISO Code 16/13, SAE Class 4 or better
Approx. Weight	0.17 kg (0.37 lbs.)
Cavity	CAVT11A (See BC Section for more details)

Performance Curves

Relief & Pilot Performance 1 to 2

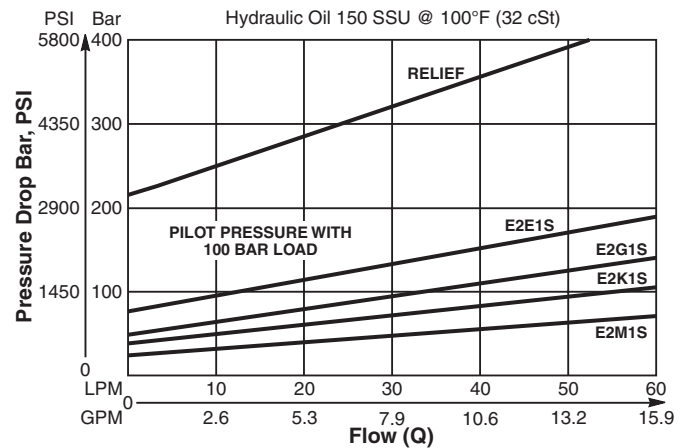

Pressure Drop vs Flow

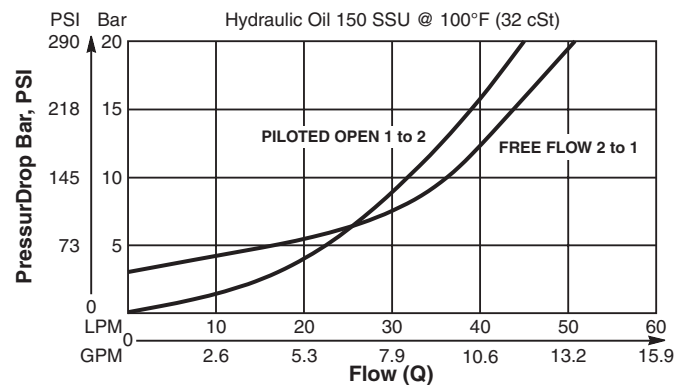

Dimensions Millimeters (Inches)

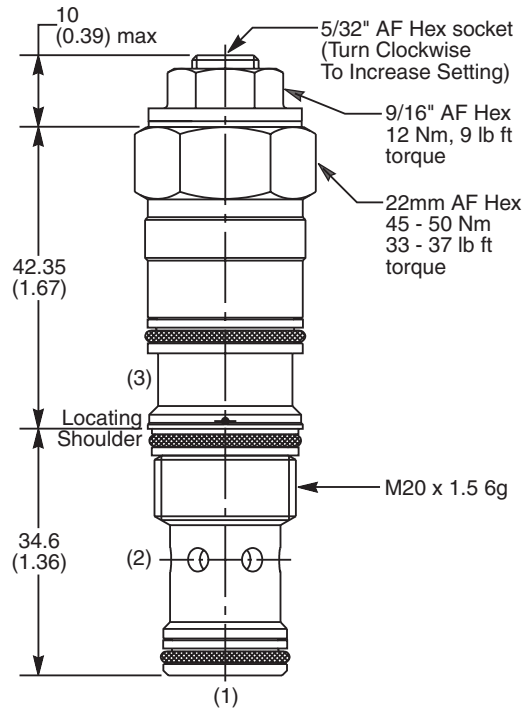

Ordering Information

E2		1S			
Load Control Valve	Pilot Ratio	Adjustment Style	Cracking Pressure	Seals	

Code	Pilot Ratio
E	1.5 : 1
G	2.3 : 1
K	3 : 1
M	4.5 : 1

Code	Cracking Pressure
	Omit for no setting (Standard)* Specify setting if required

**Standard valve is set to crack at 215 Bar (3120 PSI). Valve to be set to 1.3 times maximum load induced pressure.*

Code	Adjustment Style / Kit No.
Z	Screw Adjust (Standard)
T	Tamper Resistant (TC1131)

Code	Seals / Kit No.
N	Nitrile, Buna-N (Std.) / (SK30700N-1)
V	Fluorocarbon / (SK30700V-1)

Order Bodies Separately

LB10		
Line Body	Porting	Body Material

Code	Porting
826	1/2" BSP (main) 1/4" BSP (aux)
825	1/2" SAE (main) 1/4" SAE (aux)
828	1/2" BSP Dual Cavity
827	1/2" SAE Dual Cavity

Code	Body Material
A	Aluminum
S	Steel

Technical Information

- CV Check Valves
- SH Shuttle Valves
- LM Load/Motor Controls
- FC Flow Controls
- PC Pressure Controls
- LE Logic Elements
- DC Directional Controls
- MV Manual Valves
- SV Solenoid Valves
- PV Proportional Valves
- CE Coils & Electronics
- BC Bodies & Cavities
- TD Technical Data

General Description

Threaded Cartridge Style Counterbalance Valve. Restrictive Ports 2 to 3. Pilot assisted, designed for motion control applications. For additional information see Technical Tips on pages LM1-LM4.

Features

- Poppet construction for minimal leakage
- Incorporates direct acting relief valve for overload protection
- Includes reverse check valve within body, saving space and minimizing installation cost
- Fully sealed pilot for high efficiency and accurate pilot ratio
- Two pilot ratios available, 3:1 and 4.5:1
- Hardened working parts for maximum durability
- All external parts zinc plated

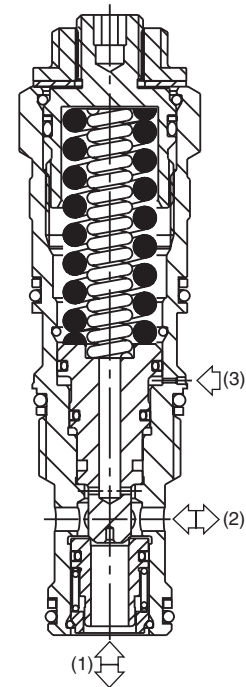
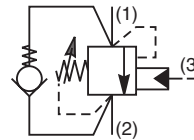
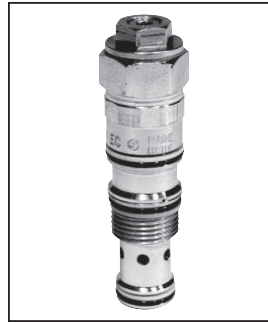

Specifications

Rated Flow	Free flow 60 LPM (16 GPM) Piloted open flow 38 LPM (10 GPM)
Pressure	90 - 350 Bar (1305 - 5000 PSI)
Sensitivity: Pressure/Turn	104 Bar (1508 PSI)
Pilot Ratio	E2K1R - 3 : 1 E2M1R - 4.5 : 1
Cartridge Material	All parts steel. All operating parts hardened steel.
Operating Temp. Range/Seals	-40°C to +93.3°C (Nitrile) (-40°F to +200°F) -31.7°C to +121.1°C (Fluorocarbon) (-25°F to +250°F)
Fluid Compatibility/ Viscosity	Mineral-based or synthetic with lubricating properties at viscosities of 45 to 2000 SSU (6 to 420 cSt)
Filtration	ISO Code 16/13, SAE Class 4 or better
Approx. Weight	0.17 kg (0.37 lbs.)
Cavity	CAVT11A (See BC Section for more details)

Performance Curves

Relief & Pilot Performance 1 to 2

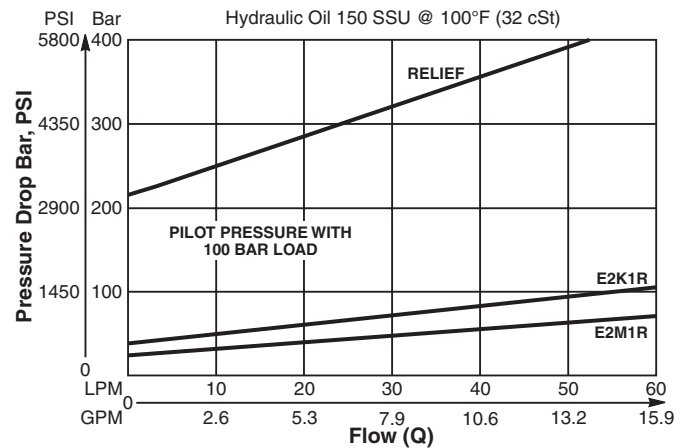

Pressure Drop vs Flow

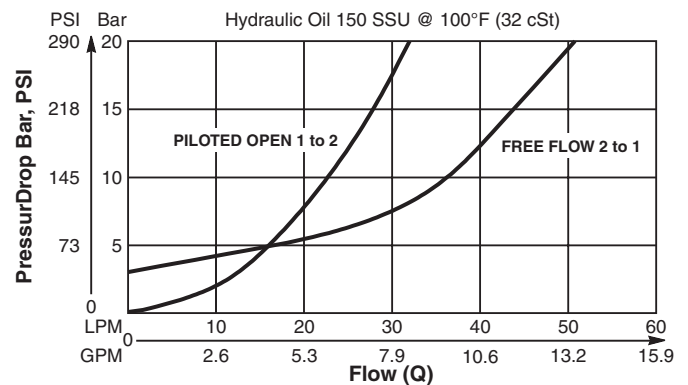

Dimensions Millimeters (Inches)

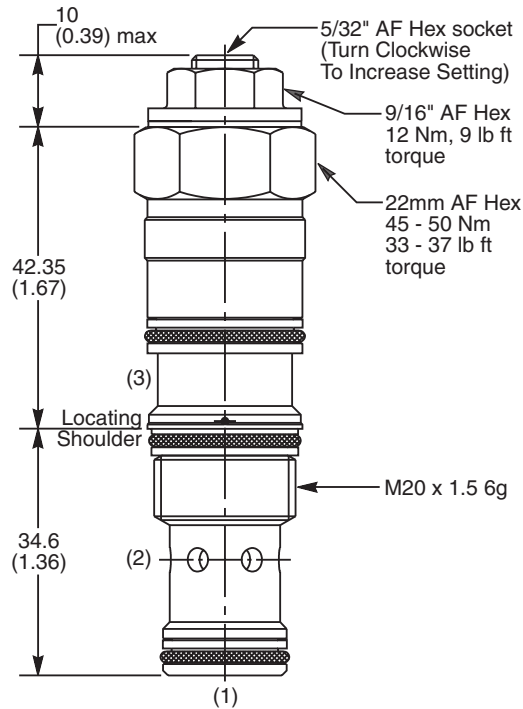

Ordering Information

E2		1R			
Load Control Valve	Pilot Ratio	Adjustment Style	Cracking Pressure	Seals	

Code	Pilot Ratio
K	3 : 1
M	4.5 : 1

Code	Adjustment Style / Kit No.
Z	Screw Adjust (Standard)
T	Tamper Resistant (TC1131)

Code	Cracking Pressure
	Omit for no setting (Standard)* Specify setting if required

**Standard valve is set to crack at 215 Bar (3120 PSI). Valve to be set to 1.3 times maximum load induced pressure.*

Code	Seals / Kit No.
N	Nitrile, Buna-N (Std.) / (SK30700N-1)
V	Fluorocarbon / (SK30700V-1)

Order Bodies Separately

LB10		
Line Body	Porting	Body Material

Code	Porting
826	1/2" BSP (main) 1/4" BSP (aux)
825	1/2" SAE (main) 1/4" SAE (aux)
828	1/2" BSP Dual Cavity
827	1/2" SAE Dual Cavity

Code	Body Material
A	Aluminum
S	Steel

- CV** Check Valves
- SH** Shuttle Valves
- LM** Load/Motor Controls
- FC** Flow Controls
- PC** Pressure Controls
- LE** Logic Elements
- DC** Directional Controls
- MV** Manual Valves
- SV** Solenoid Valves
- PV** Proportional Valves
- CE** Coils & Electronics
- BC** Bodies & Cavities
- TD** Technical Data

General Description

Threaded Cartridge Style Counterbalance Valve. Pilot assisted, designed for motion control applications. For additional information see Technical Tips on pages LM1-LM4.

Features

- Poppet construction for minimal leakage
- Incorporates direct acting relief valve for overload protection
- Includes reverse check valve within body, saving space and minimizing installation cost
- Excellent control and very good stability
- Four pilot ratios available, 1.75:1, 3:1, and 5:1 for cylinders and 8:1 for motor control
- Hardened working parts for maximum durability
- Adjustable and tamper resistant versions also available
- All external parts zinc plated

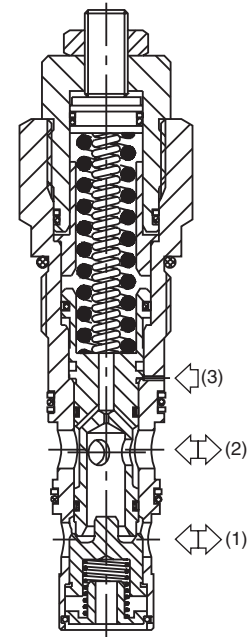
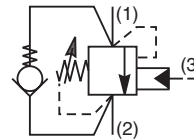

Specifications

Rated Flow	120 LPM (32 GPM)
Pressure	50 - 350 Bar (725 - 5000 PSI)
Sensitivity: Pressure/Turn	44 Bar (640 PSI)
Pilot Ratio	E2A060 - 8 : 1 E2B060 - 3 : 1 E2H060 - 1.75 : 1 E2J060 - 5 : 1
Cartridge Material	All parts steel. All operating parts hardened steel.
Operating Temp. Range/Seals	-40°C to +93.3°C (Nitrile) (-40°F to +200°F) -31.7°C to +121.1°C (Fluorocarbon) (-25°F to +250°F)
Fluid Compatibility/ Viscosity	Mineral-based or synthetic with lubricating properties at viscosities of 45 to 2000 SSU (6 to 420 cSt)
Filtration	ISO Code 16/13, SAE Class 4 or better
Approx. Weight	0.54 kg (1.19 lbs.)
Cavity	3C (See BC Section for more details)

Performance Curves

Relief & Pilot Performance 1 to 2

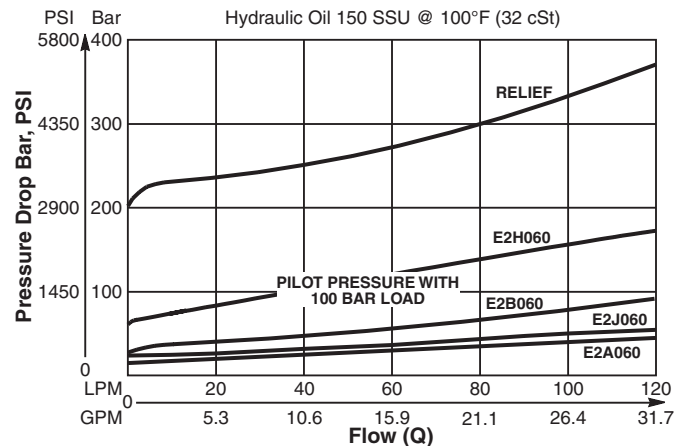

Pressure Drop vs Flow

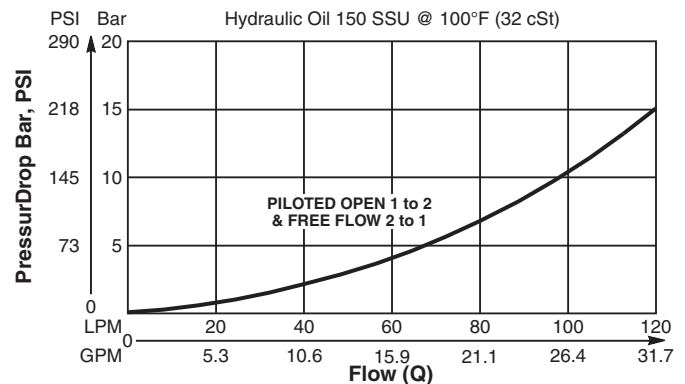

Dimensions Millimeters (Inches)

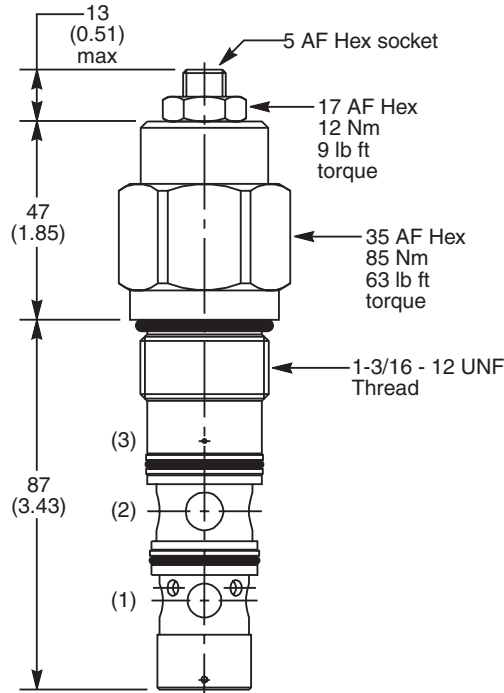

Ordering Information

E2		060				MK2
Load Control Valve	Pilot Ratio		Adjustment Style	Cracking Pressure	Seals	

Code	Pilot Ratio
A	8 : 1
B	3 : 1
H	1.75 : 1
J	5 : 1

Code	Cracking Pressure
	Omit for no setting (Standard)* Specify setting if required

**Standard valve is set to crack at 215 Bar (3120 PSI). Valve to be set to 1.3 times maximum load induced pressure.*

Code	Adjustment Style / Kit No.
Z	Screw Adjust (Standard)
T	Tamper Resistant (TC1125)

Code	Seals / Kit No.
N	Nitrile, Buna-N (Std.) / (SK30008N-1)
V	Fluorocarbon / (SK30008V-1)

Order Bodies Separately

LB10		
Line Body	Porting	Body Material

Code	Porting
039	3/4" BSP (main) 1/4" BSP (aux)
069	1" SAE (main) 1/4" SAE (aux)
034	3/4" BSP Dual Cavity
234	3/4" SAE Dual Cavity

Code	Body Material
A	Aluminum
S	Steel

Technical Information

- CV Check Valves
- SH Shuttle Valves
- LM Load/Motor Controls
- FC Flow Controls
- PC Pressure Controls
- LE Logic Elements
- DC Directional Controls
- MV Manual Valves
- SV Solenoid Valves
- PV Proportional Valves
- CE Coils & Electronics
- BC Bodies & Cavities
- TD Technical Data

General Description

Threaded Cartridge Style Counterbalance Valve. Pilot assisted, designed for motion control applications. For additional information see Technical Tips on pages LM1-LM4.

Features

- Poppet construction for minimal leakage
- Incorporates direct acting relief valve for overload protection, and reverse check valve, saving space and minimizing installation cost
- Two pilot ratios available, 3:1 for cylinders and 8:1 for motor control
- Hardened working parts for maximum durability
- Adjustable and tamper resistant versions also available
- All external parts zinc plated

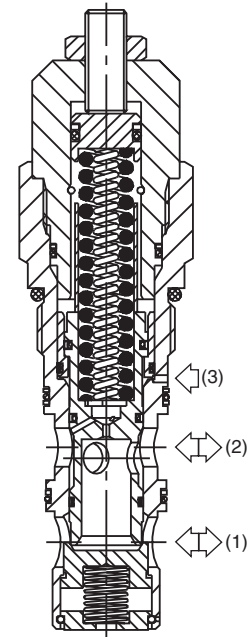
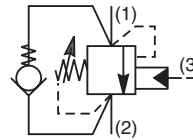

Specifications

Rated Flow	200 LPM (53 GPM)
Pressure	50 - 350 Bar (725 - 5000 PSI)
Sensitivity: Pressure/Turn	34 Bar (493 PSI)
Pilot Ratio	E2A125 - 8 : 1 E2E125 - 3 : 1
Cartridge Material	All parts steel. All operating parts hardened steel.
Operating Temp. Range/Seals	-40°C to +93.3°C (Nitrile) (-40°F to +200°F) -31.7°C to +121.1°C (Fluorocarbon) (-25°F to +250°F)
Fluid Compatibility/ Viscosity	Mineral-based or synthetic with lubricating properties at viscosities of 45 to 2000 SSU (6 to 420 cSt)
Filtration	ISO Code 16/13, SAE Class 4 or better
Approx. Weight	0.75 kg (1.65 lbs.)
Cavity	3M (See BC Section for more details)

Performance Curves

Relief & Pilot Performance 1 to 2

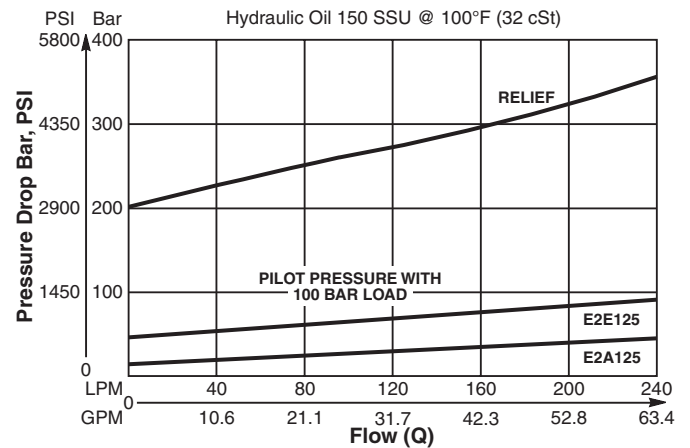

Pressure Drop vs Flow

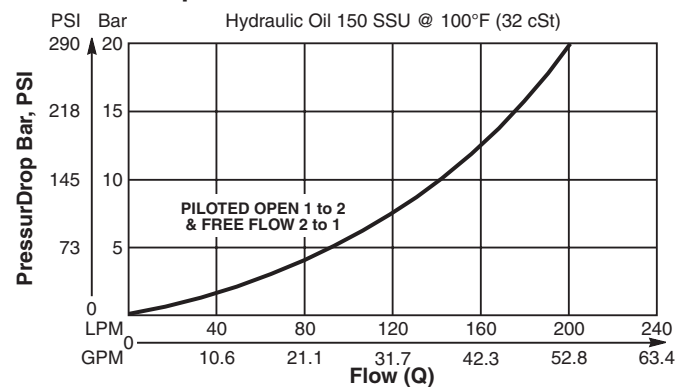

Dimensions Millimeters (Inches)

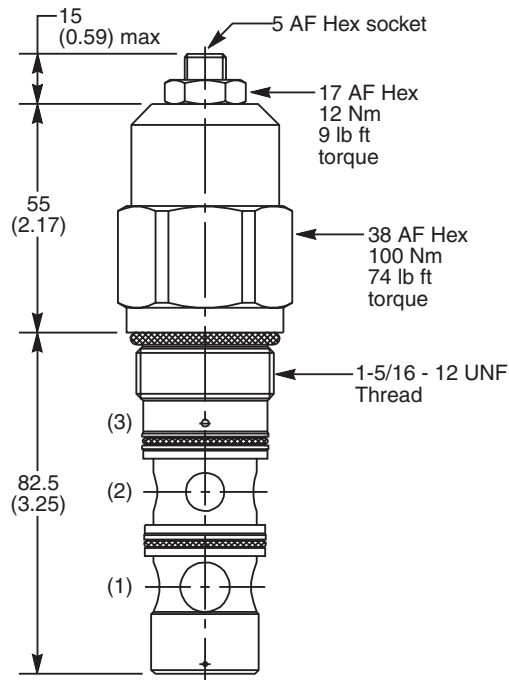

Ordering Information

E2		125				MK2
Load Control Valve	Pilot Ratio		Adjustment Style	Cracking Pressure	Seals	

Code	Pilot Ratio
A	8 : 1
E	3 : 1

Code	Adjustment Style / Kit No.
Z	Screw Adjust (Standard)
T	Tamper Resistant (TC1125)
Y	Non-Adjustable Preset

Code	Cracking Pressure
	Omit for no setting (Standard)* Specify setting if required

**Standard valve is set to crack at 215 Bar (3120 PSI). Valve to be set to 1.3 times maximum load induced pressure.*

Code	Seals / Kit No.
N	Nitrile, Buna-N (Std.) / (SK30035N-1)
V	Fluorocarbon / (SK30035V-1)

Order Bodies Separately

LB10		
Line Body	Porting	Body Material

Code	Porting
076	1" BSP (main) 1/4" BSP (aux)
078	1" SAE (main) 1/4" SAE (aux)
104	1" BSP Dual Cavity
105	1" SAE Dual Cavity

Code	Body Material
A	Aluminum
S	Steel

Technical Information

- CV Check Valves
- SH Shuttle Valves
- LM Load/Motor Controls
- FC Flow Controls
- PC Pressure Controls
- LE Logic Elements
- DC Directional Controls
- MV Manual Valves
- SV Solenoid Valves
- PV Proportional Valves
- CE Coils & Electronics
- BC Bodies & Cavities
- TD Technical Data

General Description

Threaded Cartridge Style Counterbalance Valve. Pilot assisted, designed for motion control applications. For additional information see Technical Tips on pages LM1-LM4.

Features

- Poppet construction for minimal leakage
- Incorporates direct acting relief valve for overload protection, and reverse check valve, saving space and minimizing installation cost
- Two pilot ratios available, 3:1 for cylinders and 8:1 for motor control
- Hardened working parts for maximum durability
- Adjustable and tamper resistant versions also available
- All external parts zinc plated

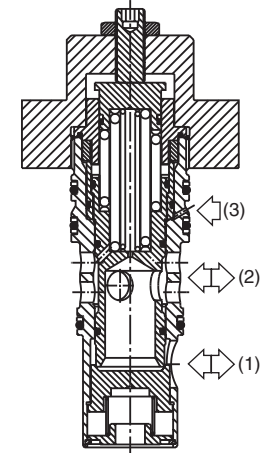
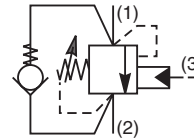
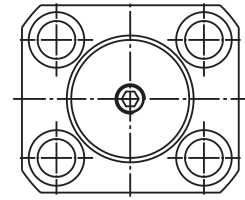

Specifications

Rated Flow	350 LPM (92 GPM)
Pressure	50 - 350 Bar (725 - 5000 PSI)
Sensitivity: Pressure/Turn	45 Bar (653 PSI)
Pilot Ratio	E2A300 - 8 : 1 E2C300 - 3 : 1
Cartridge Material	All parts steel. All operating parts hardened steel.
Operating Temp. Range/Seals	-40°C to +93.3°C (Nitrile) (-40°F to +200°F) -31.7°C to +121.1°C (Fluorocarbon) (-25°F to +250°F)
Fluid Compatibility/ Viscosity	Mineral-based or synthetic with lubricating properties at viscosities of 45 to 2000 SSU (6 to 420 cSt)
Filtration	ISO Code 16/13, SAE Class 4 or better
Approx. Weight	1.44 kg (3.17 lbs.)
Cavity	3K (See BC Section for more details)

Performance Curves

Relief & Pilot Performance 1 to 2

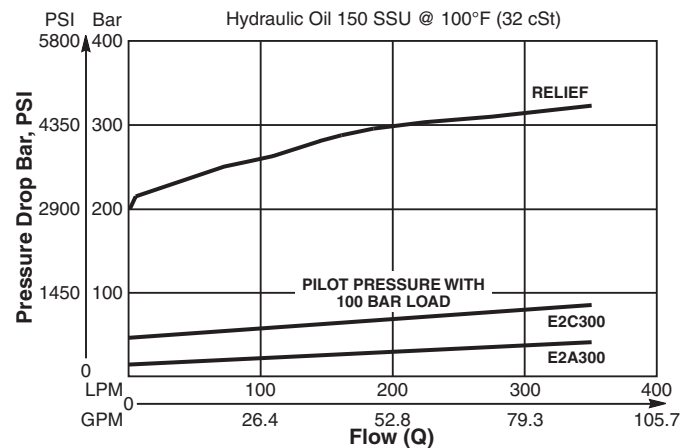

Pressure Drop vs Flow

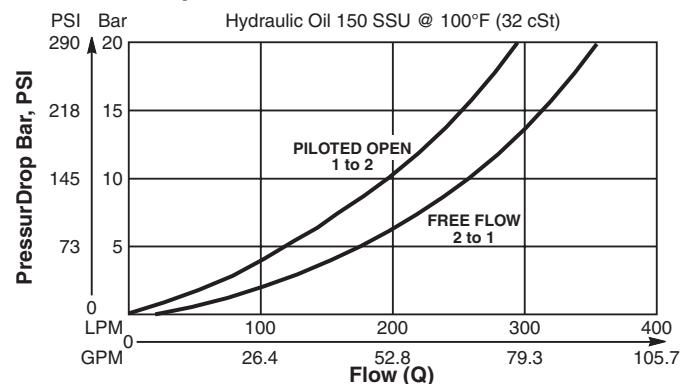

Dimensions Millimeters (Inches)

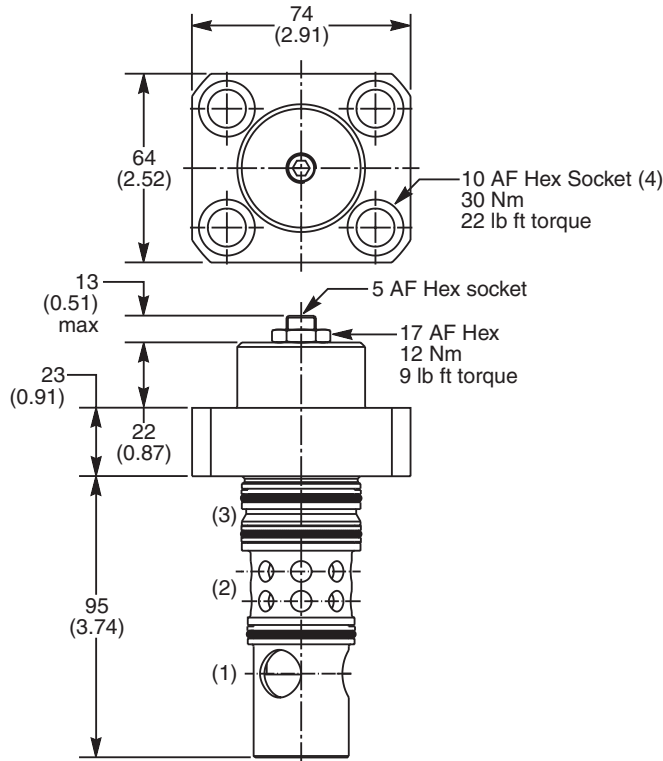

Ordering Information

E2		300				MK2
Load Control Valve	Pilot Ratio		Adjustment Style	Cracking Pressure	Seals	

Code	Pilot Ratio
A	8 : 1
C	3 : 1

Code	Adjustment Style / Kit No.
Z	Screw Adjust
T	Tamper Resistant (TC1125)

Code	Cracking Pressure
	Omit for no setting (Standard)* Specify setting if required

**Standard valve is set to crack at 215 Bar (3120 PSI). Valve to be set to 1.3 times maximum load induced pressure.*

Code	Seals / Kit No.
N	Nitrile, Buna-N (Std.) / (SK30022N-1)
V	Fluorocarbon / (SK30022V-1)

Order Bodies Separately

LB10		
Line Body	Porting	Body Material

Code	Porting
089	1-1/4" BSP (main) 1/4" BSP (aux)

Code	Body Material
A	Aluminum
S	Steel

Technical Information

- CV Check Valves
- SH Shuttle Valves
- LM Load/Motor Controls
- FC Flow Controls
- PC Pressure Controls
- LE Logic Elements
- DC Directional Controls
- MV Manual Valves
- SV Solenoid Valves
- PV Proportional Valves
- CE Coils & Electronics
- BC Bodies & Cavities
- TD Technical Data

General Description

Threaded Cartridge Style Counterbalance Valve. Pilot assisted, designed for motion control applications. For additional information see Technical Tips on pages LM1-LM4.

Features

- Spring chamber isolated from system backpressure by double seal, eliminating vent port leakage and need for separate drain line
- Poppet construction for minimal leakage
- Incorporates direct acting relief valve for overload protection
- Includes reverse check valve within body
- Small and compact, can be fitted directly into cylinder
- Adjustable and tamper resistant versions available
- All external parts zinc plated

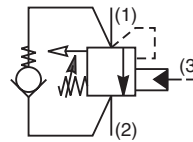
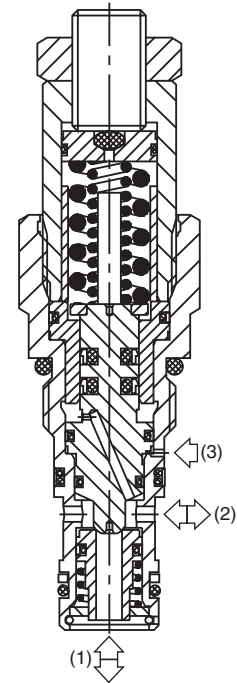

Specifications

Rated Flow	20 LPM (5.3 GPM)
Pressure	50 - 420 Bar (725 - 6000 PSI)
Sensitivity: Pressure/Turn	84 Bar (1220 PSI)
Pilot Ratio	4.5 : 1
Cartridge Material	All parts steel. All operating parts hardened steel.
Operating Temp. Range/Seals	-40°C to +93.3°C (Nitrile) (-40°F to +200°F) -31.7°C to +121.1°C (Fluorocarbon) (-25°F to +250°F)
Fluid Compatibility/ Viscosity	Mineral-based or synthetic with lubricating properties at viscosities of 45 to 2000 SSU (6 to 420 cSt)
Filtration	ISO Code 16/13, SAE Class 4 or better
Approx. Weight	0.08 kg (0.18 lbs.)
Cavity	53-1 (See BC Section for more details)

Performance Curves

Relief & Pilot Performance 1 to 2

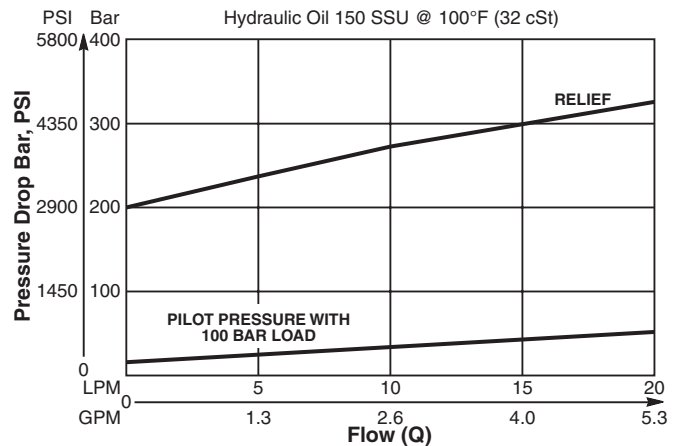

Pressure Drop vs Flow

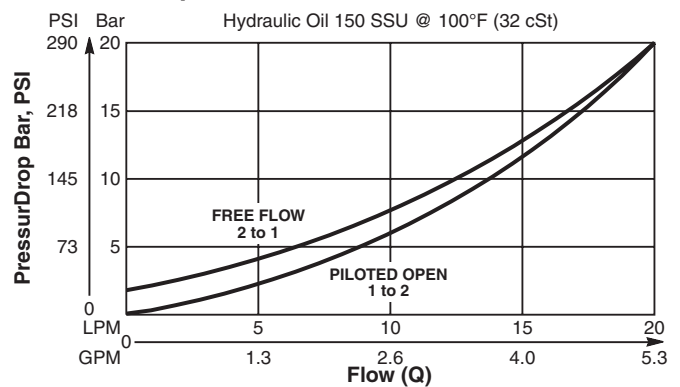

Dimensions Millimeters (Inches)

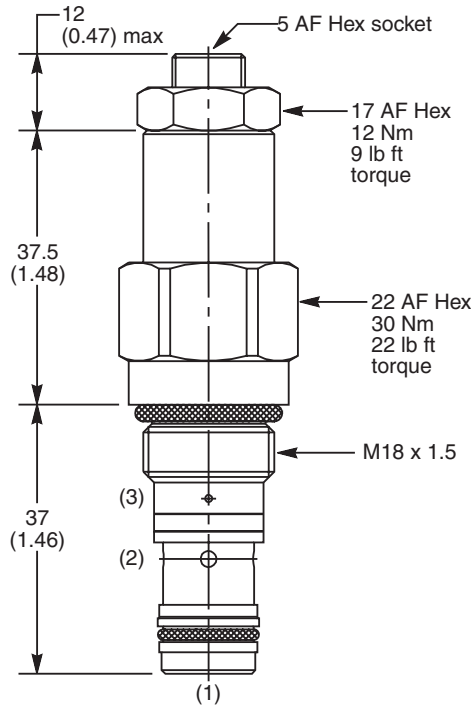

Ordering Information

E6	B	020	<input type="checkbox"/>	<input type="checkbox"/>	<input type="checkbox"/>
Load Control Valve	Pilot Ratio		Adjustment Style	Cracking Pressure	Seals

Code	Pilot Ratio
B	4.5 : 1

Code	Adjustment Style / Kit No.
Z	Screw Adjust (Standard)
T	Tamper Resistant (TC1125)

Code	Cracking Pressure
	Omit for no setting (Standard)* Specify setting if required

**Standard valve is set to crack at 215 Bar (3120 PSI). Valve to be set to 1.3 times maximum load induced pressure.*

Code	Seals / Kit No.
N	Nitrile, Buna-N (Std.) / (SK30087N-1)
V	Fluorocarbon / (SK30087V-1)

Order Bodies Separately

LB10	<input type="checkbox"/>	<input type="checkbox"/>
Line Body	Porting	Body Material

Code	Porting
310	3/8" BSP (main) 1/4" BSP (aux)
318	3/8" SAE (main) 1/4" SAE (aux)
312	3/8" BSP Dual Cavity
319	3/8" SAE Dual Cavity

Code	Body Material
A	Aluminum
S	Steel

- CV** Check Valves
- SH** Shuttle Valves
- LM** Load/Motor Controls
- FC** Flow Controls
- PC** Pressure Controls
- LE** Logic Elements
- DC** Directional Controls
- MV** Manual Valves
- SV** Solenoid Valves
- PV** Proportional Valves
- CE** Coils & Electronics
- BC** Bodies & Cavities
- TD** Technical Data

Technical Information

- CV Check Valves
- SH Shuttle Valves
- LM Load/Motor Controls
- FC Flow Controls
- PC Pressure Controls
- LE Logic Elements
- DC Directional Controls
- MV Manual Valves
- SV Solenoid Valves
- PV Proportional Valves
- CE Coils & Electronics
- BC Bodies & Cavities
- TD Technical Data

General Description

Threaded Cartridge Style Counterbalance Valve. Pilot assisted, designed for motion control applications. For additional information see Technical Tips on pages LM1-LM4.

Features

- Spring chamber isolated from system backpressure by double seal, eliminating vent port leakage and need for separate drain line
- Poppet construction for minimal leakage
- Suitable for remote pilot controlled boomlock applications as per ISO8463
- Incorporates direct acting relief valve for overload protection
- Includes reverse check valve within body
- Hardened working parts for maximum durability
- Adjustable and tamper resistant versions available
- All external parts zinc plated

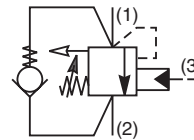
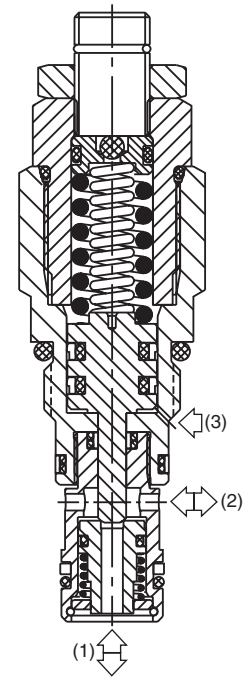
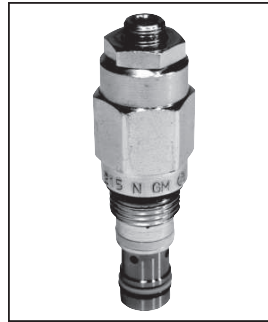

Specifications

Rated Flow	20 LPM (5.3 GPM)
Pressure	100 - 350 Bar (1450 - 5075 PSI)
Sensitivity: Pressure/Turn	114 Bar (1650 PSI)
Pilot Ratio	15 : 1
Cartridge Material	All parts steel. All operating parts hardened steel.
Operating Temp. Range/Seals	-40°C to +93.3°C (Nitrile) (-40°F to +200°F) -31.7°C to +121.1°C (Fluorocarbon) (-25°F to +250°F)
Fluid Compatibility/ Viscosity	Mineral-based or synthetic with lubricating properties at viscosities of 45 to 2000 SSU (6 to 420 cSt)
Filtration	ISO Code 16/13, SAE Class 4 or better
Approx. Weight	0.08 kg (0.18 lbs.)
Cavity	53-1 (See BC Section for more details)

Performance Curves

Relief & Pilot Performance 1 to 2

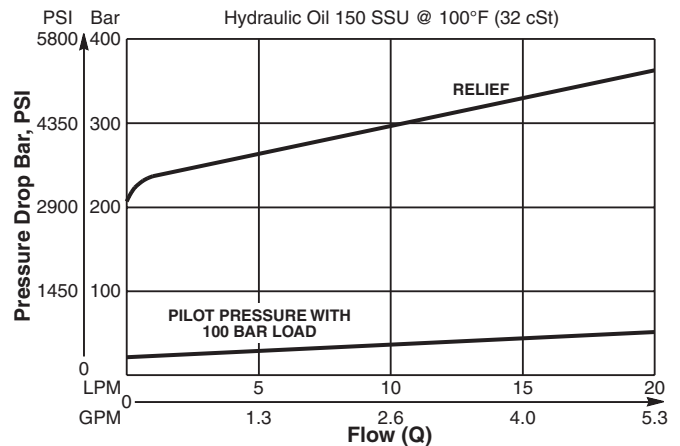

Pressure Drop vs Flow

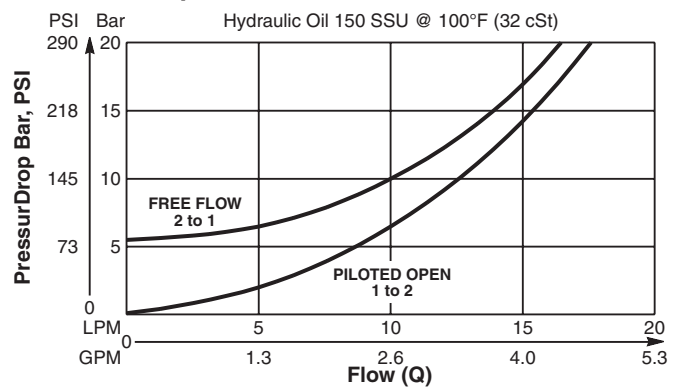

Dimensions Millimeters (Inches)

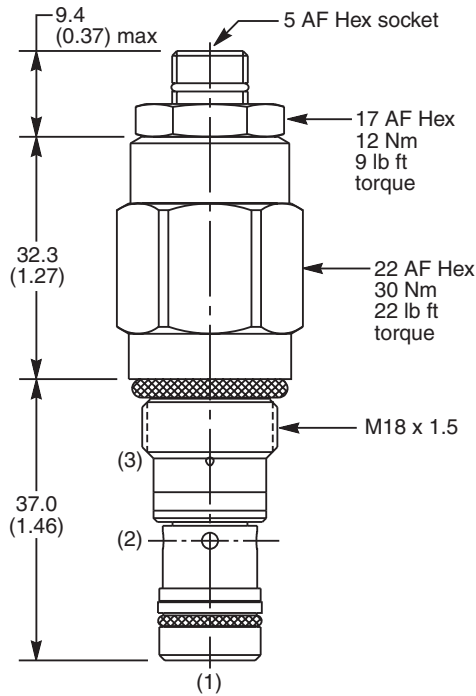

Ordering Information

E6	K	020	<input type="checkbox"/>	<input type="checkbox"/>	<input type="checkbox"/>
Load Control Valve	Pilot Ratio		Adjustment Style	Cracking Pressure	Seals

Code	Pilot Ratio
K	15 : 1

Code	Adjustment Style / Kit No.
Z	Screw Adjust (Standard)
T	Tamper Resistant (TC1125)

Code	Cracking Pressure
	Omit for no setting (Standard)* Specify setting if required

**Standard valve is set to crack at 215 Bar (3120 PSI). Valve to be set to 1.3 times maximum load induced pressure.*

Code	Seals / Kit No.
N	Nitrile, Buna-N (Std.) / (SK30087N-1)
V	Fluorocarbon / (SK30087V-1)

Order Bodies Separately

LB10	<input type="checkbox"/>	<input type="checkbox"/>
Line Body	Porting	Body Material

Code	Porting
310	3/8" BSP (main) 1/4" BSP (aux)
318	3/8" SAE (main) 1/4" SAE (aux)
312	3/8" BSP Dual Cavity
319	3/8" SAE Dual Cavity

Code	Body Material
A	Aluminum
S	Steel

- CV** Check Valves
- SH** Shuttle Valves
- LM** Load/Motor Controls
- FC** Flow Controls
- PC** Pressure Controls
- LE** Logic Elements
- DC** Directional Controls
- MV** Manual Valves
- SV** Solenoid Valves
- PV** Proportional Valves
- CE** Coils & Electronics
- BC** Bodies & Cavities
- TD** Technical Data

- CV** Check Valves
- SH** Shuttle Valves
- LM** Load/Motor Controls
- FC** Flow Controls
- PC** Pressure Controls
- LE** Logic Elements
- DC** Directional Controls
- MV** Manual Valves
- SV** Solenoid Valves
- PV** Proportional Valves
- CE** Coils & Electronics
- BC** Bodies & Cavities
- TD** Technical Data

General Description

Threaded Cartridge Style Counterbalance Valve. 3 Port, Independent of Back Pressure, Vented to Atmosphere. Pilot assisted, designed for motion control applications. For additional information see Technical Tips on pages LM1-LM4.

Features

- Spring chamber isolated from system back pressure by double seal, eliminating vent port leakage and need for separate drain line
- Poppet construction for minimal leakage
- Incorporates direct acting relief valve for overload protection
- Includes reverse check valve within body, saving space and minimizing installation cost
- Fully sealed pilot for high efficiency and accurate pilot ratio
- Three pilot ratios available, 1:1, 3:1 and 5:1
- Adjustable and tamper resistant versions available
- All external parts zinc plated

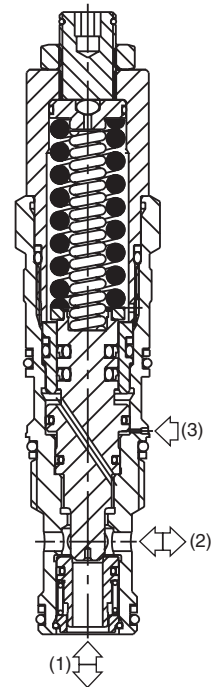
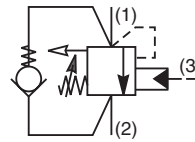
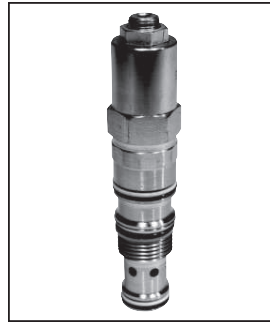

Specifications

Rated Flow	60 LPM (16 GPM)
Pressure	40 - 350 Bar (580 - 5000 PSI)
Sensitivity: Pressure/Turn	78 Bar (1131 PSI)
Pilot Ratio	E6C1 - 1 : 1 E6K1 - 3 : 1 E6P1 - 5 : 1
Cartridge Material	All parts steel. All operating parts hardened steel.
Operating Temp. Range/Seals	-40°C to +93.3°C (Nitrile) (-40°F to +200°F) -31.7°C to +121.1°C (Fluorocarbon) (-25°F to +250°F)
Fluid Compatibility/ Viscosity	Mineral-based or synthetic with lubricating properties at viscosities of 45 to 2000 SSU (6 to 420 cSt)
Filtration	ISO Code 16/13, SAE Class 4 or better
Approx. Weight	0.22 kg (0.48 lbs.)
Cavity	CAVT11A (See BC Section for more details)

Performance Curves

Relief & Pilot Performance 1 to 2

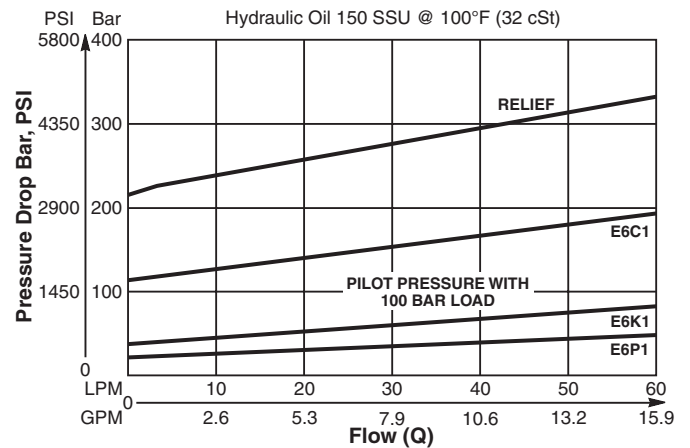

Pressure Drop vs Flow

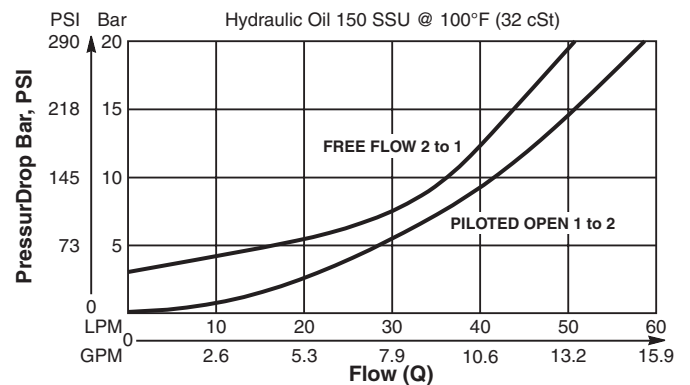

Dimensions Millimeters (Inches)

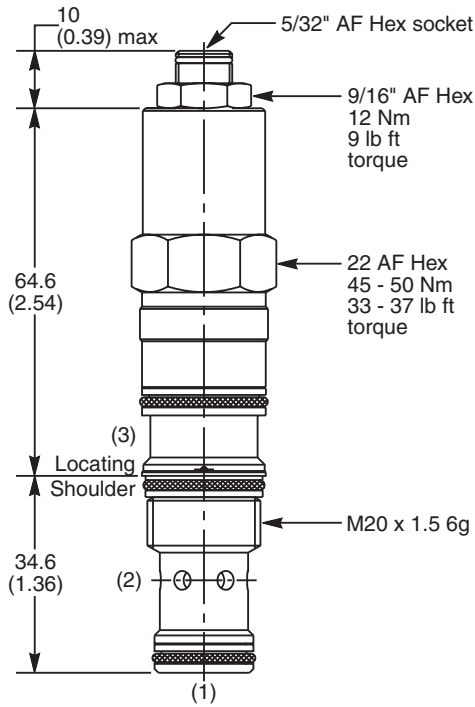

Ordering Information

E6		1			
Load Control Valve	Pilot Ratio	Adjustment Style	Cracking Pressure	Seals	

Code	Pilot Ratio
C	1 : 1
K	3 : 1
P	5 : 1

Code	Adjustment Style / Kit No.
Z	Screw Adjust (Standard)
T	Tamper Resistant (TC1130)

Code	Cracking Pressure
	Omit for no setting (Standard)* Specify setting if required

**Standard valve is set to crack at 215 Bar (3120 PSI). Valve to be set to 1.3 times maximum load induced pressure.*

Code	Seals / Kit No.
N	Nitrile, Buna-N (Std.) / (SK30700N-1)
V	Fluorocarbon / (SK30700V-1)

Order Bodies Separately

LB10		
Line Body	Porting	Body Material

Code	Porting
826	1/2" BSP (main) 1/4" BSP (aux)
825	1/2" SAE (main) 1/4" SAE (aux)
828	1/2" BSP Dual Cavity
827	1/2" SAE Dual Cavity

Code	Body Material
A	Aluminum
S	Steel

Technical Information

- CV Check Valves
- SH Shuttle Valves
- LM Load/Motor Controls
- FC Flow Controls
- PC Pressure Controls
- LE Logic Elements
- DC Directional Controls
- MV Manual Valves
- SV Solenoid Valves
- PV Proportional Valves
- CE Coils & Electronics
- BC Bodies & Cavities
- TD Technical Data

General Description

Threaded Cartridge Style Counterbalance Valve. Pilot assisted, designed for motion control applications. For additional information see Technical Tips on pages LM1-LM4.

Features

- Spring chamber isolated from system backpressure by double seal, eliminating vent port leakage and need for separate drain line
- Poppet construction for minimal leakage
- Incorporates direct acting relief valve for overload protection
- Includes reverse check valve within body, saving space and minimizing installation cost
- Hardened working parts for maximum durability
- Adjustable and tamper resistant versions available
- All external parts zinc plated

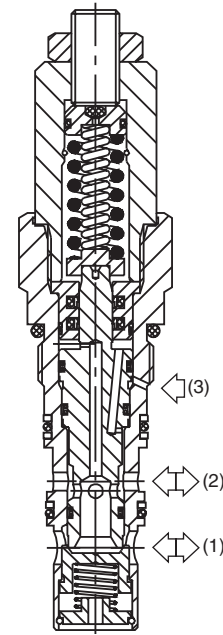
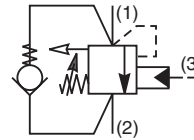
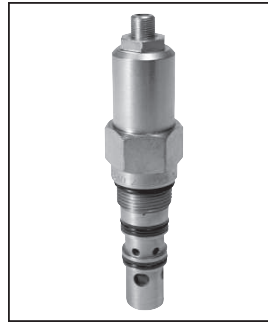

Specifications

Rated Flow	60 LPM (15.9 GPM)
Pressure	50 - 350 Bar (725 - 5000 PSI)
Sensitivity: Pressure/Turn	92 Bar (1335 PSI)
Pilot Ratio	3 : 1
Cartridge Material	All parts steel. All operating parts hardened steel.
Operating Temp. Range/Seals	-40°C to +93.3°C (Nitrile) (-40°F to +200°F) -31.7°C to +121.1°C (Fluorocarbon) (-25°F to +250°F)
Fluid Compatibility/ Viscosity	Mineral-based or synthetic with lubricating properties at viscosities of 45 to 2000 SSU (6 to 420 cSt)
Filtration	ISO Code 16/13, SAE Class 4 or better
Approx. Weight	0.33 kg (0.73 lbs.)
Cavity	68-1 (See BC Section for more details)

Performance Curves

Relief & Pilot Performance 1 to 2

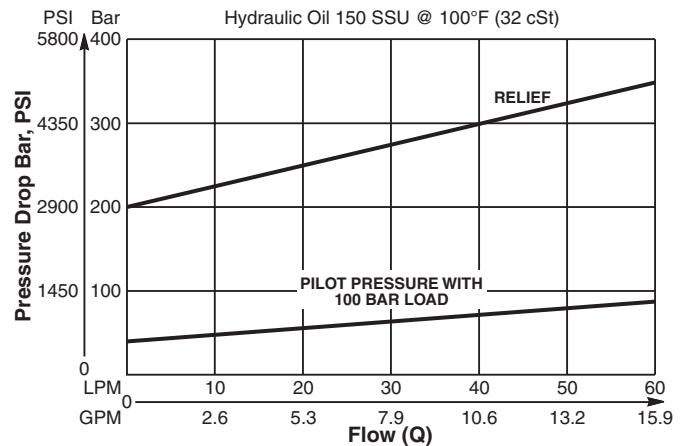

Pressure Drop vs Flow

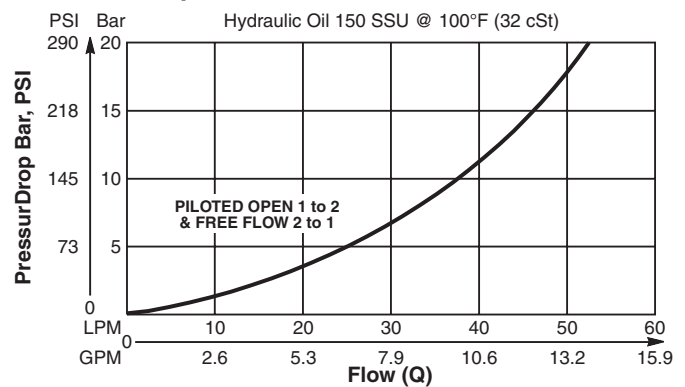

Dimensions Millimeters (Inches)

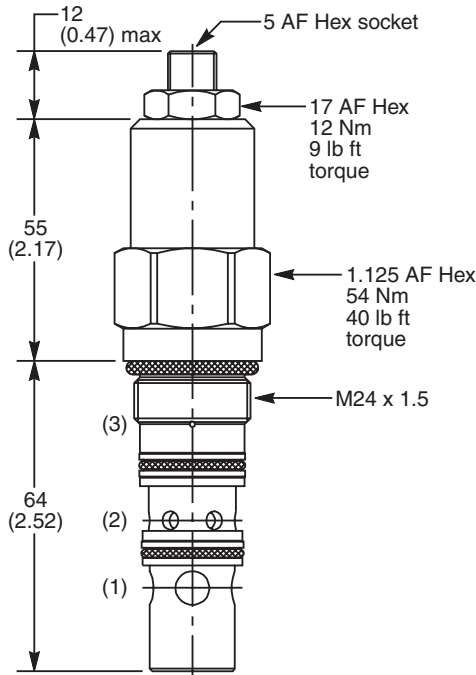

Ordering Information

E6	B	040	<input type="checkbox"/>	<input type="checkbox"/>	<input type="checkbox"/>	MK3
Load Control Valve	Pilot Ratio		Adjustment Style	Cracking Pressure	Seals	

Code	Pilot Ratio
B	3 : 1

Code	Adjustment Style / Kit No.
Z	Screw Adjust (Standard)
T	Tamper Resistant (TC1125)

Code	Cracking Pressure
	Omit for no setting (Standard)* Specify setting if required

**Standard valve is set to crack at 215 Bar (3120 PSI). Valve to be set to 1.3 times maximum load induced pressure.*

Code	Seals / Kit No.
N	Nitrile, Buna-N (Std.) / (SK30059N-1)
V	Fluorocarbon / (SK30059V-1)

Order Bodies Separately

LB10	<input type="checkbox"/>	<input type="checkbox"/>
Line Body	Porting	Body Material

Code	Porting
251	1/2" BSP (main) 1/4" BSP (aux)
253	1/2" SAE (main) 1/4" SAE (aux)
259	1/2" BSP Dual Cavity
261	1/2" SAE Dual Cavity

Code	Body Material
A	Aluminum
S	Steel

- CV** Check Valves
- SH** Shuttle Valves
- LM** Load/Motor Controls
- FC** Flow Controls
- PC** Pressure Controls
- LE** Logic Elements
- DC** Directional Controls
- MV** Manual Valves
- SV** Solenoid Valves
- PV** Proportional Valves
- CE** Coils & Electronics
- BC** Bodies & Cavities
- TD** Technical Data

- CV** Check Valves
- SH** Shuttle Valves
- LM** Load/Motor Controls
- FC** Flow Controls
- PC** Pressure Controls
- LE** Logic Elements
- DC** Directional Controls
- MV** Manual Valves
- SV** Solenoid Valves
- PV** Proportional Valves
- CE** Coils & Electronics
- BC** Bodies & Cavities
- TD** Technical Data

General Description

Threaded Cartridge Style Counterbalance Valve. Pilot assisted, designed for motion control applications. For additional information see Technical Tips on pages LM1-LM4.

Features

- High flow design with extra dampening
- Spring chamber isolated from system backpressure by double seal, eliminating vent port leakage and need for separate drain line
- Poppet construction for minimal leakage
- Incorporates direct acting relief valve for overload protection
- Includes reverse check valve within body, saving space and minimizing installation cost
- Hardened working parts for maximum durability
- Adjustable and tamper resistant versions available
- All external parts zinc plated

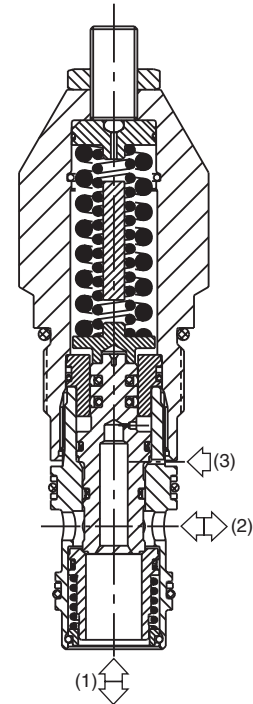
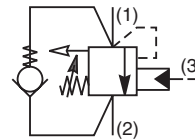
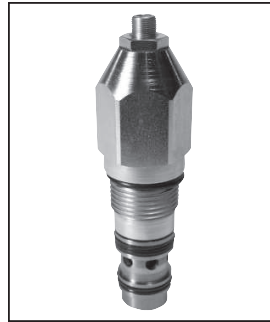

Specifications

Rated Flow	180 LPM (48 GPM)
Pressure	50 - 350 Bar (725 - 5000 PSI)
Sensitivity: Pressure/Turn	50 Bar (725 PSI)
Pilot Ratio	E6A060*409 - 8 : 1 E6B060*409 - 3 : 1
Cartridge Material	All parts steel. All operating parts hardened steel.
Operating Temp. Range/Seals	-40°C to +93.3°C (Nitrile) (-40°F to +200°F) -31.7°C to +121.1°C (Fluorocarbon) (-25°F to +250°F)
Fluid Compatibility/ Viscosity	Mineral-based or synthetic with lubricating properties at viscosities of 45 to 2000 SSU (6 to 420 cSt)
Filtration	ISO Code 16/13, SAE Class 4 or better
Approx. Weight	0.53 kg (1.17 lbs.)
Cavity	3C (See BC Section for more details)

Performance Curves

Relief & Pilot Performance 1 to 2

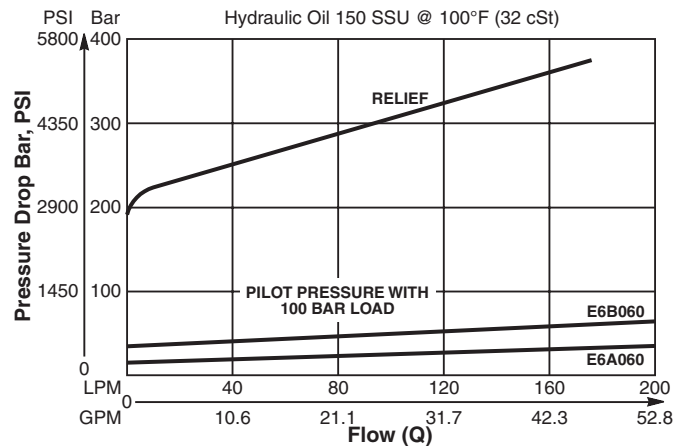

Pressure Drop vs Flow

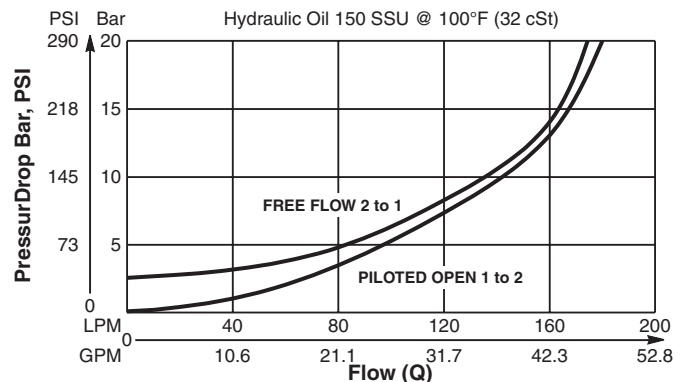

Dimensions Millimeters (Inches)

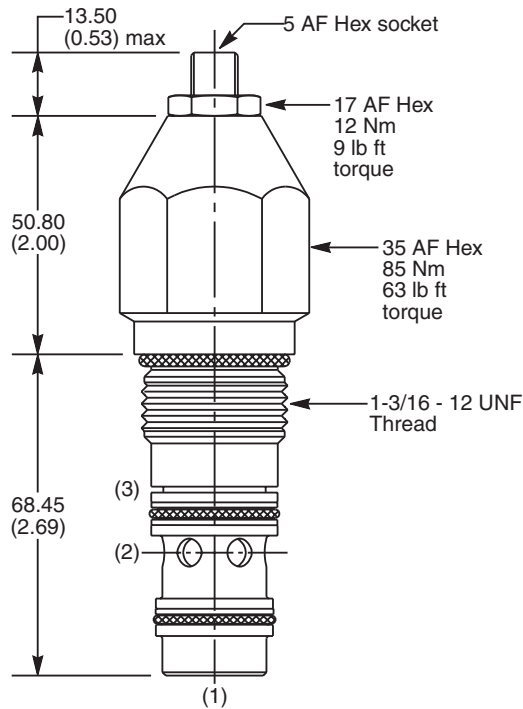

Ordering Information

E6		060				409
Load Control Valve	Pilot Ratio	Adjustment Style	Cracking Pressure	Seals	Suffix Number	

Code	Pilot Ratio
A	8 : 1
B	3 : 1

Code	Adjustment Style / Kit No.
Z	Screw Adjust (Standard)
T	Tamper Resistant (TC1125)

Code	Cracking Pressure
	Omit for no setting (Standard)* Specify setting if required

**Standard valve is set to crack at 215 Bar (3120 PSI). Valve to be set to 1.4 times maximum load induced pressure.*

Code	Seals / Kit No.
N	Nitrile, Buna-N (Std.) / (SK30008N-1)
V	Fluorocarbon / (SK30008V-1)

Code	Suffix Number
409	High flow design with extra dampening

Order Bodies Separately

LB10		
Line Body	Porting	Body Material

Code	Porting
039	3/4" BSP (main) 1/4" BSP (aux)
069	1" SAE (main) 1/4" SAE (aux)
034	3/4" BSP Dual Cavity
234	3/4" SAE Dual Cavity

Code	Body Material
A	Aluminum
S	Steel

- CV** Check Valves
- SH** Shuttle Valves
- LM** Load/Motor Controls
- FC** Flow Controls
- PC** Pressure Controls
- LE** Logic Elements
- DC** Directional Controls
- MV** Manual Valves
- SV** Solenoid Valves
- PV** Proportional Valves
- CE** Coils & Electronics
- BC** Bodies & Cavities
- TD** Technical Data

CV Check Valves
SH Shuttle Valves
LM Load/Motor Controls
FC Flow Controls
PC Pressure Controls
LE Logic Elements
DC Directional Controls
MV Manual Valves
SV Solenoid Valves
PV Proportional Valves
CE Coils & Electronics
BC Bodies & Cavities
TD Technical Data

General Description

Manifold Mounted Motor Control Valve to fit the TB, TE, TF and TG series Parker motors. For additional information see Technical Tips on pages LM1-LM4.

Features

- Hardened and precision ground parts for long life
- Compact size for reduced space requirements
- Low leakage design
- Fluorocarbon seals standard

Specifications

Maximum Flow	56.25 LPM (15 GPM)
Maximum Operating Press.	210 Bar (3000 PSI)
Minimum Pilot Pressure	20.7 Bar (300 PSI)
Leakage at 150 SSU (32 cSt)	5 drops/min. (.33 cc/min.) @ 80% of holding pressure
Valve Material	All parts steel. All operating parts hardened steel.
Body Material	Aluminum
Operating Temp. Range/Seals	-31.7°C to +121.1°C (Fluorocarbon) (-25°F to +250°F)
Fluid Compatibility/ Viscosity	Mineral-based or synthetic with lubricating properties at viscosities of 45 to 2000 SSU (6 to 420 cSt)
Filtration	ISO Code 16/13, SAE Class 4 or better
Approx. Weight	Single 0.68 kg (1.5 lbs.) Double 1.36 kg (3.0 lbs.)
Cavity	CDD-1010 for MHC-010

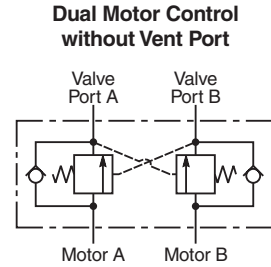

Dual Counterbalance without Brake Shuttle

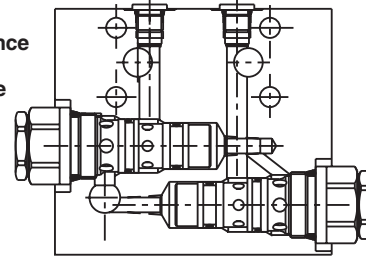

Performance Curve
Flow vs. Inlet Pressure

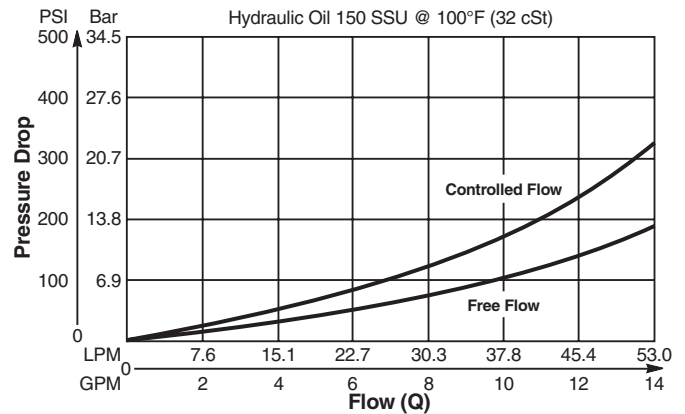

Ordering Information

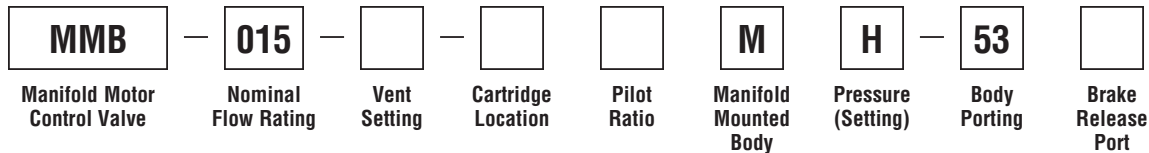

Code	Nominal Flow Rating
015	56.3 LPM (15 GPM)

Code	Cartridge Location
A	Motor Control on A Port
B	Motor Control on B Port
D	Dual Motor Control

Code	Pilot Ratio
A	1:1 Equal Area
J	10:1

Code	Body Porting
53	SAE-10 V1 and V2 Ports

Code	Vent Setting
Omit	No Vent
V	Vent

Code	Pressure (Setting)
H	Hold Pressure 210 Bar (3000 PSI) Brake Release Pressure 24.1 Bar (350 PSI)

Code	Brake Release Port
N	No Port (Dual Motor Control Only)
B	SAE-6

MMB-015-A*MH-53B

A Port Motor Control with Brake Release Shuttle, Non-Vented Cartridge

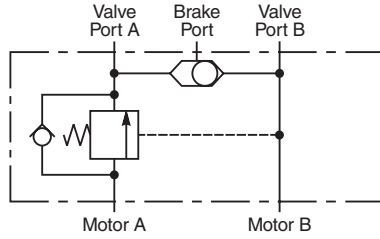

MMB-015-V-A*MH-53B

A Port Motor Control with Brake Release Shuttle, Vented Cartridge

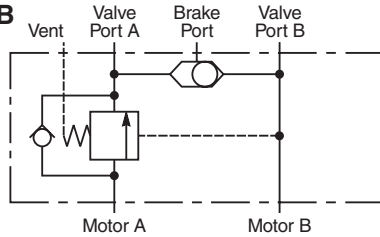

MMB-015-B*MH-53B

B Port Motor Control with Brake Release Shuttle, Non-Vented Cartridge

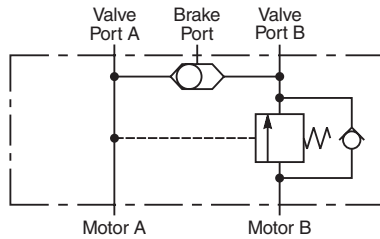

MMB-015-V-B*MH-53B

B Port Motor Control with Brake Release Shuttle, Vented Cartridge

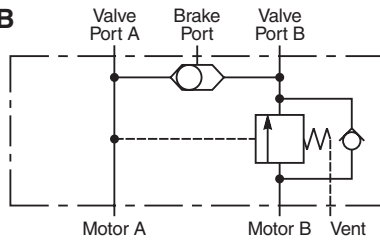

MMB-015-D*MH-53B

Dual Motor Control with Brake Release Shuttle, Non-Vented Cartridges

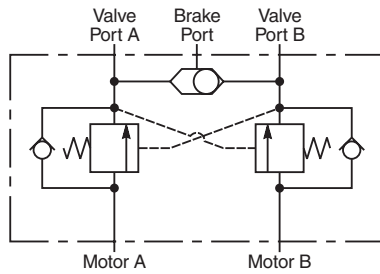

MMB-015-V-D*MH-53B

Dual Motor Control with Brake Release Shuttle, Vented Cartridges

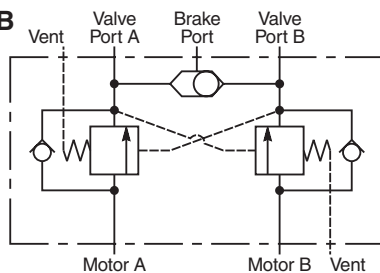

MMB-015-A*MH-53B

(Non-Vented)

MMB-015-V-A*MH-53B

(Vented)

A Port Motor Control Manifold Mount with Brake Shuttle

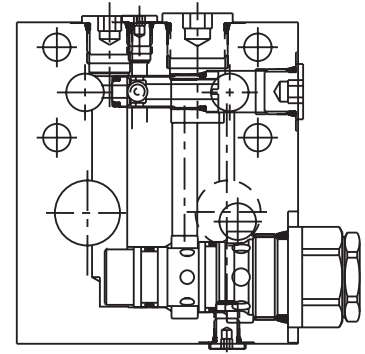

MMB-015-B*MH-53B

(Non-Vented)

MMB-015-V-B*MH-53B

(Vented)

B Port Motor Control Manifold Mount with Brake Shuttle

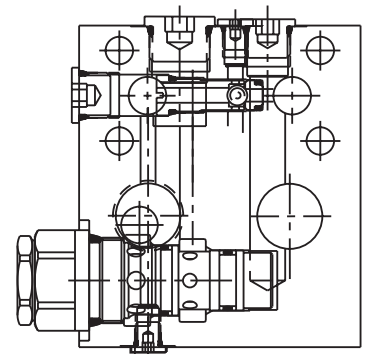

MMB-015-D*MH-53B (Non-Vented)

MMB-015-V-D*MH-53B (Vented)

Dual Counterbalance with Brake Shuttle

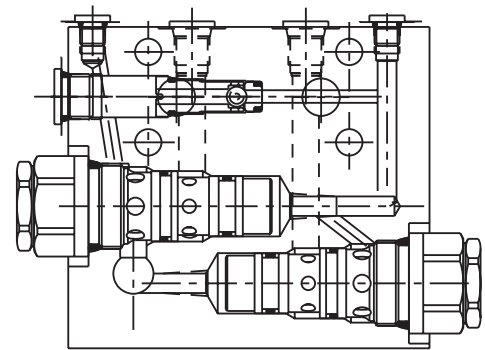

CV

Check Valves

SH

Shuttle Valves

LM

Load/Motor Controls

FC

Flow Controls

PC

Pressure Controls

LE

Logic Elements

DC

Directional Controls

MV

Manual Valves

SV

Solenoid Valves

PV

Proportional Valves

CE

Coils & Electronics

BC

Bodies & Cavities

TD

Technical Data

Dimensions

*Inch equivalents for millimeter dimensions are shown in (**)

Series MMB-015-A*MH-53B
A Port Motor Control Non-Vented Cartridge

A & B Ports are #10 SAE (7/8-14 UNF-2B Thread)
Brake Shuttle Port is #6 SAE (9/16-18 UNF-2B Thread)
.343 Dia. Thru (4) Mounting Holes

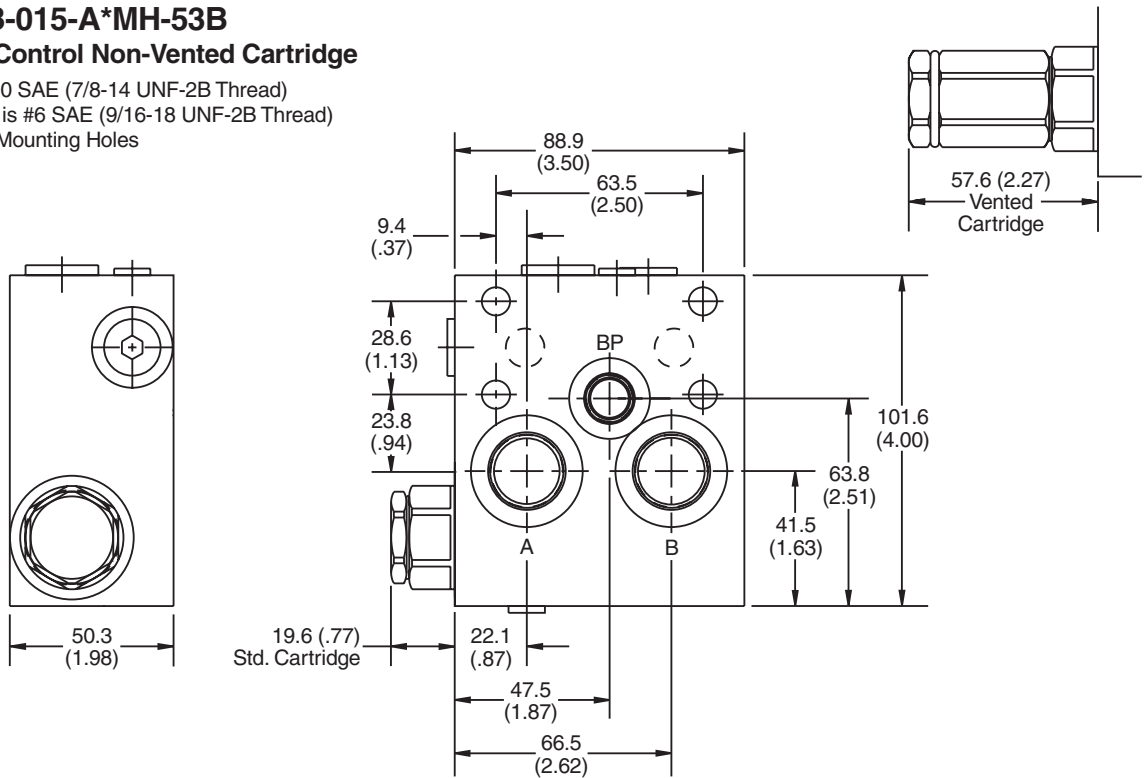

Series MMB-015-D*MH-53B
Dual Motor Control Valve Non-Vented Cartridges
SAE-10 Porting with SAE-6 Brake Port

A & B Ports are #10 SAE (7/8-14 UNC-2B Thread)
Brake Shuttle Port is #6 SAE (9/16-18 UN-2B Thread)
.343 Dia. Thru (4) Mounting Holes

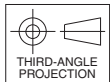
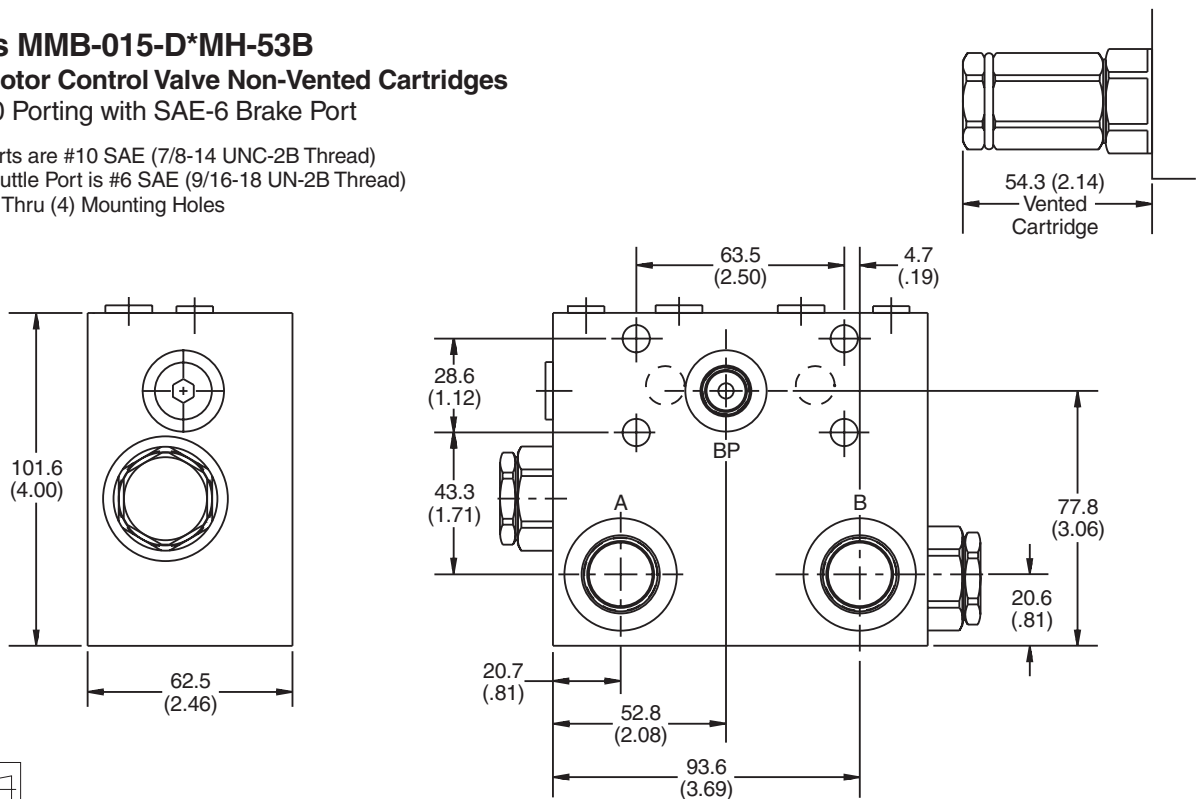

- CV** Check Valves
- SH** Shuttle Valves
- LM** Load/Motor Controls
- FC** Flow Controls
- PC** Pressure Controls
- LE** Logic Elements
- DC** Directional Controls
- MV** Manual Valves
- SV** Solenoid Valves
- PV** Proportional Valves
- CE** Coils & Electronics
- BC** Bodies & Cavities
- TD** Technical Data

General Description

Manifold Mounted Motor Control Valve to fit the TB, TE, TF and TG series Parker motors. For additional information see Technical Tips on pages LM1-LM4.

Features

- Hardened and precision ground parts for long life
- Compact size for reduced space requirements
- Low leakage design
- Fluorocarbon seals standard

Specifications

Maximum Flow	93.75 LPM (25 GPM)
Maximum Operating Press.	210 Bar (3000 PSI)
Minimum Pilot Pressure	20.7 Bar (300 PSI)
Leakage at 150 SSU (32 cSt)	5 drops/min. (.33 cc/min.) @ 80% of holding pressure
Valve Material	All parts steel. All operating parts hardened steel.
Body Material	Aluminum
Operating Temp. Range/Seals	-31.7°C to +121.1°C (Fluorocarbon) (-25°F to +250°F)
Fluid Compatibility/ Viscosity	Mineral-based or synthetic with lubricating properties at viscosities of 45 to 2000 SSU (6 to 420 cSt)
Filtration	ISO Code 16/13, SAE Class 4 or better
Approx. Weight	Single 1.54 kg (3.4 lbs.) Double 3.10 kg (6.8 lbs.)
Cavity	CDD-1036 for MHC-022

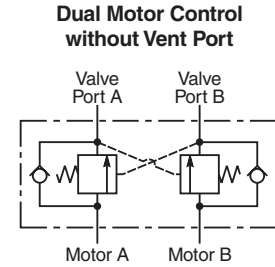

Dual Counterbalance without Brake Shuttle

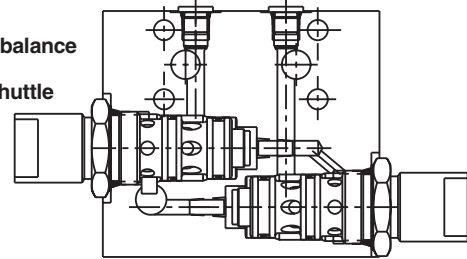

Performance Curve
Flow vs. Inlet Pressure

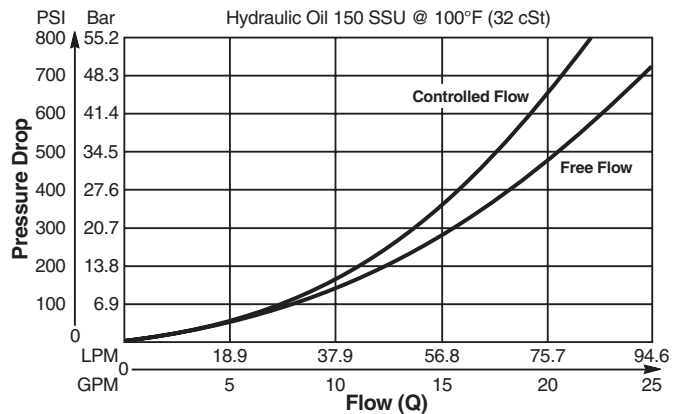

Ordering Information

MMB — **025** — — — — **M** — **H** — **54** —

Manifold Motor Control Valve Nominal Flow Rating Vent Setting Cartridge Location Pilot Ratio Manifold Mounted Body Pressure (Setting) Body Porting Brake Release Port

Code	Nominal Flow Rating
025	93.8 LPM (25 GPM)

Code	Cartridge Location
A	Motor Control on A Port
B	Motor Control on B Port
D	Dual Motor Control

Code	Pilot Ratio
A	1:1 Equal Area
J	10:1

Code	Body Porting
54	SAE-12 V1 and V2 Ports

Code	Vent Setting
Omit	No Vent
V	Vent

Code	Pressure (Setting)
H	Hold Pressure 210 Bar (3000 PSI) Brake Release Pressure 24.1 Bar (350 PSI)

Code	Brake Release Port
N	No Port
B	SAE-6

CV	Check Valves
SH	Shuttle Valves
LM	Load/Motor Controls
FC	Flow Controls
PC	Pressure Controls
LE	Logic Elements
DC	Directional Controls
MV	Manual Valves
SV	Solenoid Valves
PV	Proportional Valves
CE	Coils & Electronics
BC	Bodies & Cavities
TD	Technical Data

MMB-025-A*MH-54B

A Port Motor Control with Brake Release Shuttle, Non-Vented Cartridge

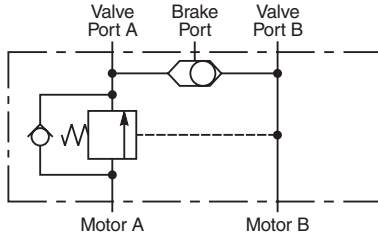

MMB-025-A*MH-54B (Non-Vented)

MMB-025-V-A*MH-54B (Vented)
A Port Motor Control with Brake Release Shuttle

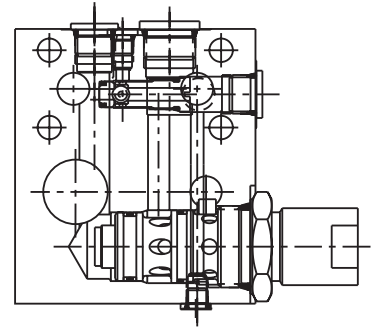

MMB-025-V-A*MH-54B

A Port Motor Control with Brake Release Shuttle, Vented Cartridge

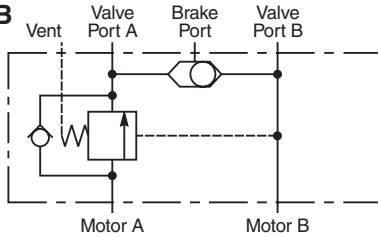

MMB-025-B*MH-54B (Non-Vented)

MMB-025-V-B*MH-54B (Vented)
B Port Motor Control with Brake Release Shuttle

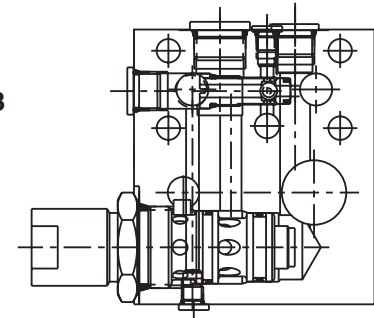

MMB-025-B*MH-54B

B Port Motor Control with Brake Release Shuttle, Non-Vented Cartridge

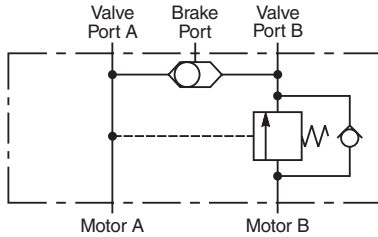

MMB-025-V-B*MH-54B

B Port Motor Control with Brake Release Shuttle, Vented Cartridge

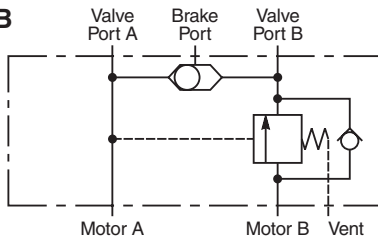

MMB-025-D*MH-54B (Non-Vented)

MMB-025-V-D*MH-54B (Vented)
Dual Motor Control with Brake Release Shuttle

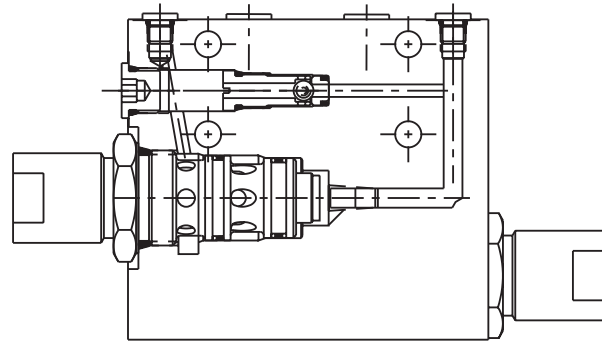

MMB-025-D*MH-54B

Dual Motor Control with Brake Release Shuttle, Non-Vented Cartridges

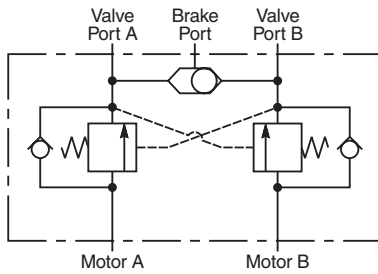

MMB-025-V-D*MH-54B

Dual Motor Control with Brake Release Shuttle, Vented Cartridges

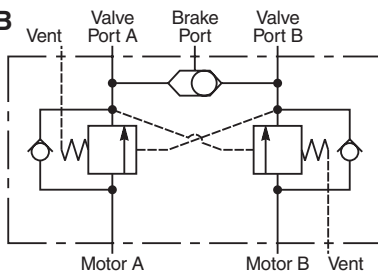

*Inch equivalents for millimeter dimensions are shown in (**)

**Series MMB-025-B*MH-54B
 B Port Motor Control Non-Vented Cartridge**

A & B Ports are #12 SAE (1/16-12 UN-2B Thread)
 Brake Shuttle Port is #6 SAE (9/16-18 UNF-2B Thread)
 .344 Dia. Thru (4) Mounting Holes
 C'Bored .50 Dia. x .31 DP

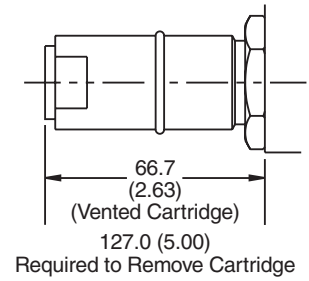
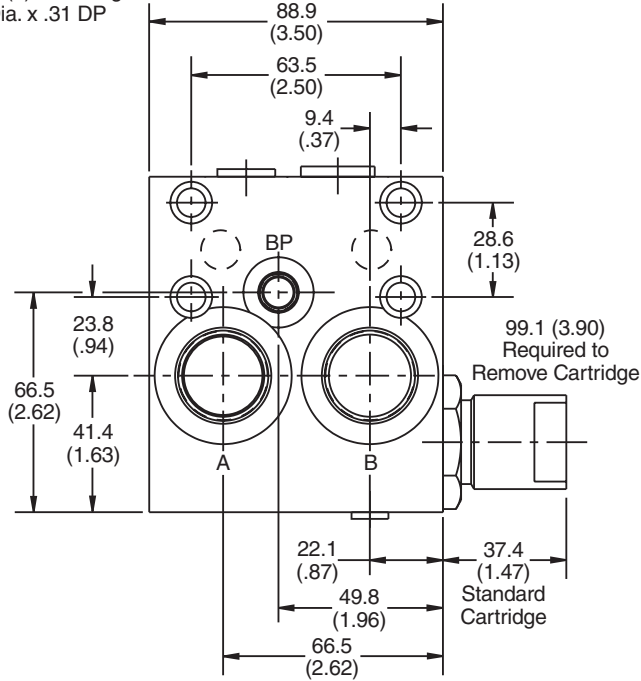

**Series MMB-025-D*MH-54B
 Dual Motor Control Valve Non-Vented Cartridges**

A & B Ports are #12 SAE (1/16-12 UN-2B Thread)
 Brake Shuttle Port is #6 SAE (9/16-18 UNF-2B Thread)
 .344 Dia. Thru (4) Mounting Holes

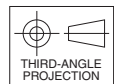
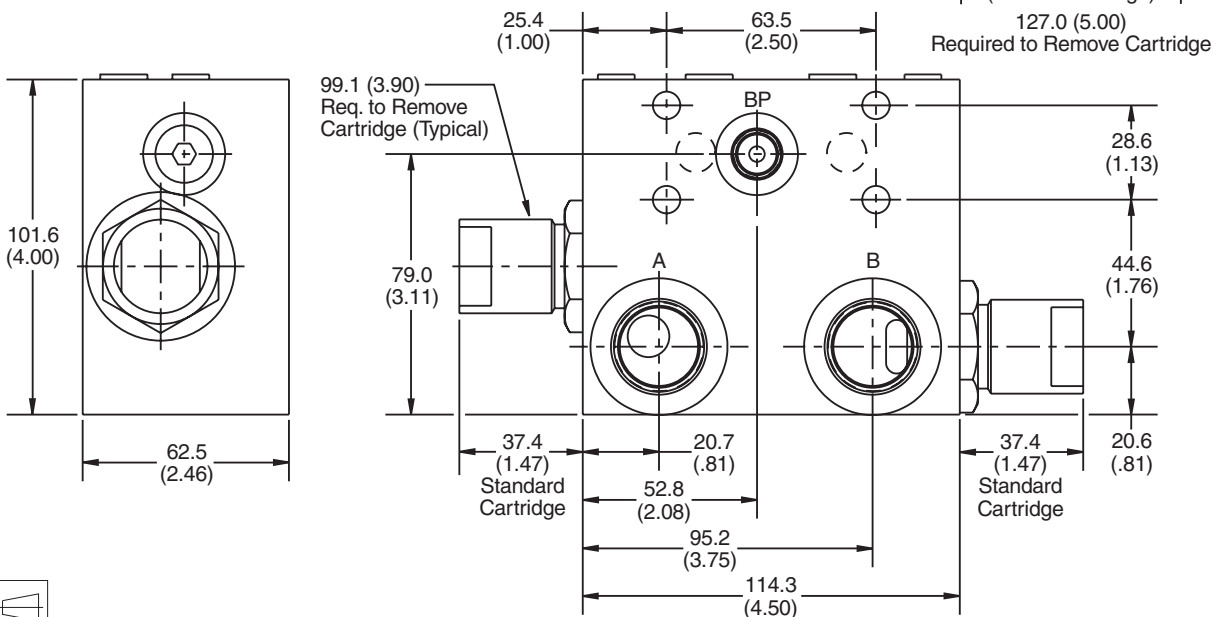

CV
Check Valves
SH
Shuttle Valves
LM
Load/Motor Controls
FC
Flow Controls
PC
Pressure Controls
LE
Logic Elements
DC
Directional Controls
MV
Manual Valves
SV
Solenoid Valves
PV
Proportional Valves
CE
Coils & Electronics
BC
Bodies & Cavities
TD
Technical Data

- CV** Check Valves
- SH** Shuttle Valves
- LM** Load/Motor Controls
- FC** Flow Controls
- PC** Pressure Controls
- LE** Logic Elements
- DC** Directional Controls
- MV** Manual Valves
- SV** Solenoid Valves
- PV** Proportional Valves
- CE** Coils & Electronics
- BC** Bodies & Cavities
- TD** Technical Data

General Description

Threaded Cartridge Style Counterbalance Valve. 4 Port, Independent of Back Pressure, Vented to Drain Line. Pilot assisted, designed for motion control applications. For additional information see Technical Tips on pages LM1-LM4.

Features

- Spring chamber isolated from system back pressure by vent port and use of separate drain line
- Poppet construction for minimal leakage
- Incorporates direct acting relief valve for overload protection
- Includes reverse check valve, saving space and minimizing installation cost
- Fully sealed pilot for high efficiency and accurate pilot ratio
- Three pilot ratios available, 1:1, 3:1 and 5:1
- Adjustable and tamper resistant versions available
- All external parts zinc plated

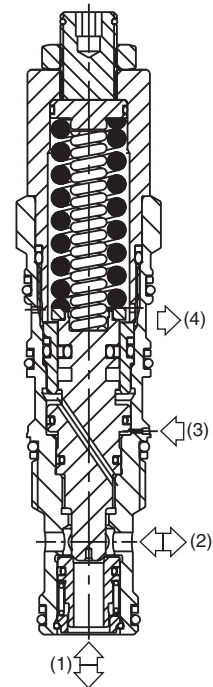
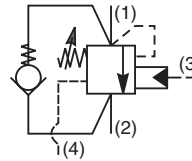
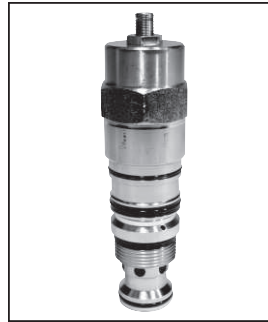

Specifications

Rated Flow	60 LPM (16 GPM)
Pressure	40 - 350 Bar (580 - 5000 PSI)
Sensitivity: Pressure/Turn	78 Bar (1131 PSI)
Pilot Ratio	E9C1 - 1 : 1 E9K1 - 3 : 1 E9P1 - 5 : 1
Cartridge Material	All parts steel. All operating parts hardened steel.
Operating Temp. Range/Seals	-40°C to +93.3°C (Nitrile) (-40°F to +200°F) -31.7°C to +121.1°C (Fluorocarbon) (-25°F to +250°F)
Fluid Compatibility/ Viscosity	Mineral-based or synthetic with lubricating properties at viscosities of 45 to 2000 SSU (6 to 420 cSt)
Filtration	ISO Code 16/13, SAE Class 4 or better
Approx. Weight	0.22 kg (0.48 lbs.)
Cavity	CAVT21A (See BC Section for more details)

Performance Curves

Relief & Pilot Performance 2 to 3

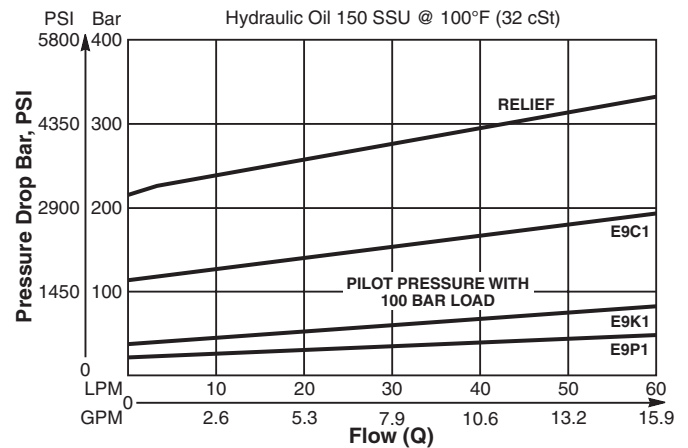

Pressure Drop vs Flow

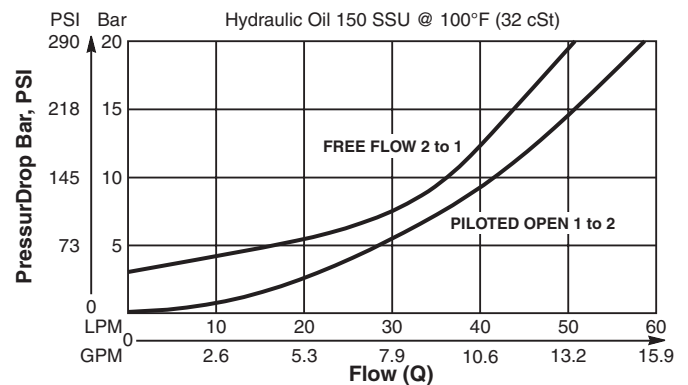

Dimensions Millimeters (Inches)

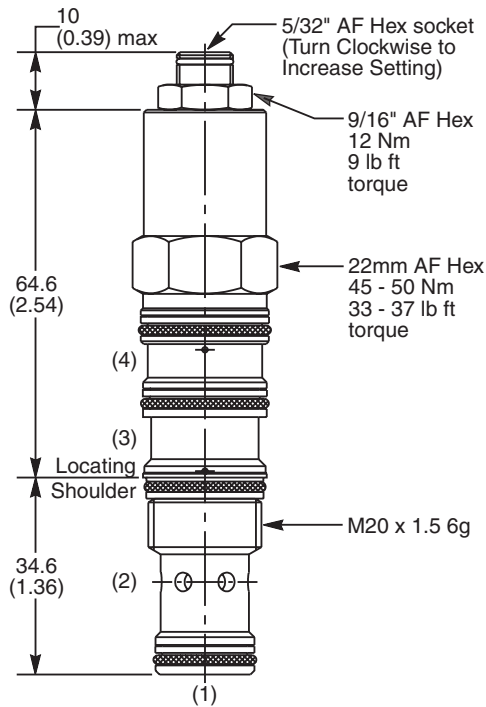

Ordering Information

E9		1			
Load Control Valve	Pilot Ratio	Adjustment Style	Cracking Pressure	Seals	

Code	Pilot Ratio
C	1 : 1
K	3 : 1
P	5 : 1

Code	Cracking Pressure
	Omit for no setting (Standard)* Specify setting if required

**Standard valve is set to crack at 215 Bar (3120 PSI). Valve to be set to 1.3 times maximum load induced pressure.*

Code	Adjustment Style / Kit No.
Z	Screw Adjust (Standard)
T	Tamper Resistant (TC1130)

Code	Seals / Kit No.
N	Nitrile, Buna-N (Std.) / (SK30701N-1)
V	Fluorocarbon / (SK30701V-1)

Order Bodies Separately

LB10		
Line Body	Porting	Body Material

Code	Porting
831	1/2" BSP (main) 3/8" BSP (pilot) 1/4" BSP (drain)
830	1/2" SAE (main) 3/8" SAE (pilot) 1/4" SAE (drain)

Code	Body Material
A	Aluminum
S	Steel

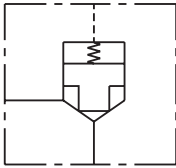
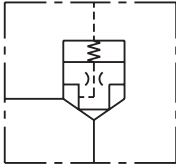
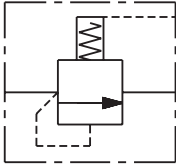
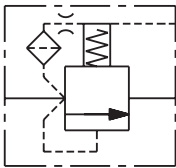
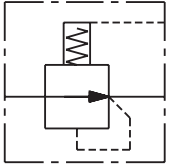
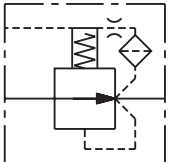
	SERIES	CAVITY	DESCRIPTION	FLOW LPM/GPM	PRESSURE BAR/PSI	PAGE NO.
	POPPET TYPE					
	10SLC1-A	C10-3S	Normally Closed, Pilot to Close	57/15	240/3500	LE7
	16SLC1-A	C16-3S	Normally Closed, Pilot to Close	189/50	240/3500	LE8
	20SLC1-A	C20-3S	Normally Closed, Pilot to Close	303/80	240/3500	LE9
	16SLC1-C	C16-3S	Normally Closed, Vent to Open	189/50	240/3500	LE10
	SPOOL TYPE					
	10SLC2-A	C10-3S	Normally Closed, Pilot to Close	57/15	240/3500	LE11
	16SLC2-A	C16-3S	Normally Closed, Pilot to Close	189/50	240/3500	LE12
	20SLC2-A	C20-3S	Normally Closed, Pilot to Close	303/80	240/3500	LE13
	R04E3	C10-3S	Normally Closed, Pilot to Close	170/45	420/6000	LE14
	R06E3	C16-3S	Normally Closed, Pilot to Close	400/106	420/6000	LE15
	R08E3	C20-3S	Normally Closed, Pilot to Close	500/132	420/6000	LE16
	10SLC2-B	C10-3S	Normally Closed, Vent to Open	57/15	240/3500	LE17
	16SLC2-B	C16-3S	Normally Closed, Vent to Open	189/50	240/3500	LE18
	20SLC2-B	C20-3S	Normally Closed, Vent to Open	303/80	240/3500	LE19
	R04F3	C10-3S	Normally Closed, Vent to Open	170/45	420/6000	LE20
	R06F3	C16-3S	Normally Closed, Vent to Open	400/106	420/6000	LE21
	R08F3	C20-3S	Normally Closed, Vent to Open	500/132	420/6000	LE22
	10SLC3-A	C10-3S	Normally Open, Vent to Close	57/15	240/3500	LE23
	16SLC3-A	C16-3S	Normally Open, Vent to Close	189/50	240/3500	LE24
	R04H3	C10-3S	Normally Open, Vent to Close	57/15	420/6000	LE25
	R06H3	C16-3S	Normally Open, Vent to Close	160/42	420/6000	LE26
	10SLC3-B	C10-3S	Normally Open, Vent to Close	57/15	240/3500	LE27
	16SLC3-B	C16-3S	Normally Open, Vent to Close	189/50	240/3500	LE28
	R04G3	C10-3S	Normally Open, Vent to Close	57/15	420/6000	LE29
	R06G3	C16-3S	Normally Open, Vent to Close	160/42	420/6000	LE30

- CV**
Check Valves
- SH**
Shuttle Valves
- LM**
Load/Motor Controls
- FC**
Flow Controls
- PC**
Pressure Controls
- LE**
Logic Elements
- DC**
Directional Controls
- MV**
Manual Valves
- SV**
Solenoid Valves
- PV**
Proportional Valves
- CE**
Coils & Electronics
- BC**
Bodies & Cavities
- TD**
Technical Data

- CV Check Valves
- SH Shuttle Valves
- LM Load/Motor Controls
- FC Flow Controls
- PC Pressure Controls
- LE Logic Elements
- DC Directional Controls
- MV Manual Valves
- SV Solenoid Valves
- PV Proportional Valves
- CE Coils & Electronics
- BC Bodies & Cavities
- TD Technical Data

INTRODUCTION:

Parker's logic valves offer system designers a versatile range of screw-in elements that, when used in the proper combinations, can provide flexible design solutions for many common cartridge valve applications. They offer system designers the advantage of applying cartridge valve technology in applications where the flow and pressure conditions may exceed the limits of typical cartridge valves. Logic valves are essentially high flow poppet or spool elements that are controlled by small pilot devices. They can be used to control flow, pressure, or direction, and when applied in the proper arrangements, can perform multi-task control functions. Parker's logic valves offer system designers alternative products that can help reduce the size, cost, and complexity of integrated manifold systems.

NEW PRODUCTS:

Parker Logic Valves are offered in two basic categories: Poppet and Spool.

**Now Available in
6000 PSI**

Poppet Type - Used for flow switching directional control applications.

Spool Type - Used for pressure sensing in modulating applications to regulate flow and pressure.

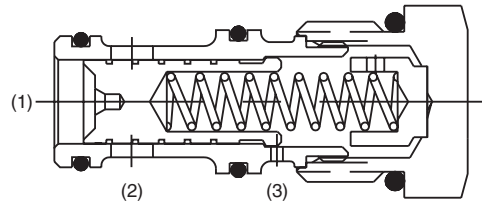
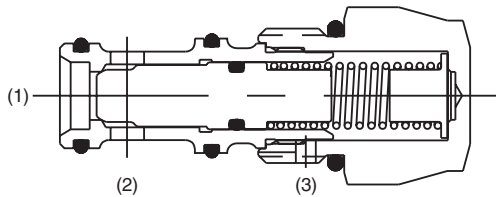

**PRODUCT TYPES / APPLICATIONS
POPPET TYPE**

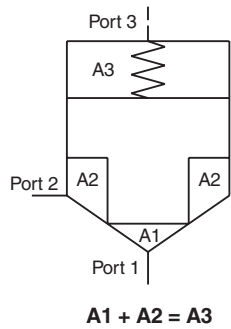

Poppet type logic valves are 3 ported, 2-way on/off valves that switch flow between port 1 and port 2. The poppet's on/off action is operated by controlling pilot oil at port 3 of the valve. A small low flow solenoid or pilot valve is an ideal control for this purpose. Parker offers vent-to-open and pilot-to-close style poppet logic valves.

Note: Poppet logic valves are an unbalanced 2:1 ratio poppet design. The opening and closing of the poppet is dependent on the force balances on the areas of the poppet at port 1, port 2, and port 3.

Vent-to-open logic valves:

Vent-to-open logic valves are primarily used for uni-directional flow switching applications. The poppet in the vent-to-open logic valve is spring biased to the closed condition. The pilot oil source that operates the logic element is generated internally by direct pressure from either work port 1 or 2, depending on the option chosen. Venting the pilot oil at port 3 allows the valve to open and pass flow between port 1 and port 2 at the bias spring setting. Blocking the pilot at port 3 causes the valve to close. When closed, the 2:1 ratio poppet design provides a positive low leak seal. Because the pilot source is generated internally within the valve, vent-to-open logic valves are best suited for uni-directional applications.

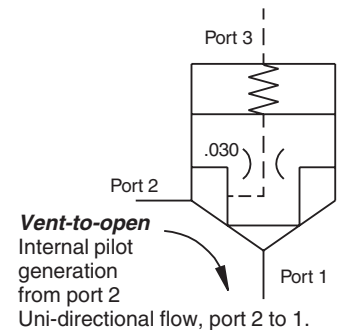
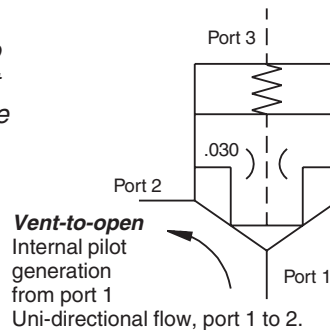

POPPET TYPE *Continued*

Pilot-to-close logic valve:

Pilot-to-close logic elements are primarily used for bi-directional flow switching applications. The poppet in the pilot-to-close logic valve is spring biased to the closed condition. With no pilot signal at port 3, the valve will open allowing flow in either direction between work ports 1 and 2 once pressure at one of the work ports reaches the biased spring setting. Applying a sufficient externally generated pilot force to port 3 of the valve closes the poppet creating a low leak seal between port 1 and port 2.

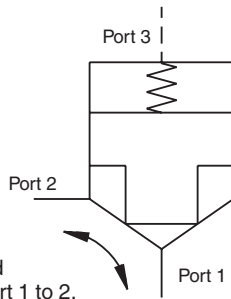

Pilot-to-close
External pilot required
Bi-directional flow, port 1 to 2.

2-way, 3-way, and 4-way Directional Control:

Poppet logic valves are typically used to perform high flow directional switching operations using small low power pilot valves to control the sequence of the directional operation.

- A single logic valve can be used to control 2-way, on/off switching.
- Multiple elements in a bridge arrangement can control 3-way or 4-way directional switching.
- Since each logic valve is individually controlled, the timing, sequence, and overlap of directional functions can be controlled very precisely.
- Uni-directional or bi-directional flow can be achieved, depending on the valve selected.
- Flows in excess of 80 gpm can be controlled through a single logic element, and more than one logic valve can be used in parallel to control flow in excess of the rated flow of a single element.
- Poppet construction provides a low leak directional control.

(See circuit examples on pages LE4-LE5)

SPOOL TYPE

Spool type logic valves can also be used for directional switching, however, they are typically used in modulating applications to control flow or regulate pressure. Virtually any pressure or flow control function can be achieved with a spool type logic valve including; restrictive or priority flow control, pressure relief, pressure reducing, sequencing, and unloading.

The spools in this category of logic valves are balanced designs; the spool area at the work port (port 1) and the pilot port (port 3) are equal (1:1). The spool is held in a biased condition by a spring. Venting the pilot at port 3 creates an unbalanced condition causing the valve spool to modulate open or close, depending on the valve chosen. This spool design makes the valve vary stable because the forces acting to open and close the valve are in balance.

Flow Control / Compensators:

Parker offers two types of logic valves for flow control functions.

- 1) Normally open spools function as a restrictive type compensator.
- 2) Normally closed spools function as a priority or by-pass compensator.

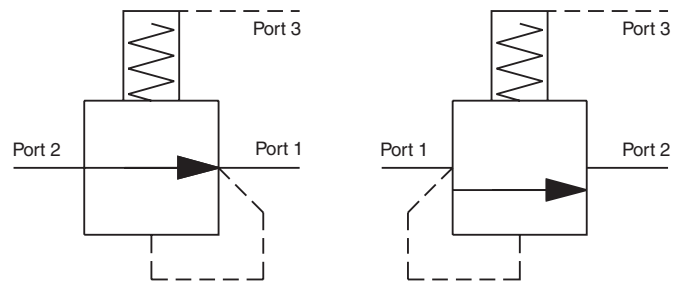

Normally open spool

Normally closed spool

- CV Check Valves
- SH Shuttle Valves
- LM Load/Motor Controls
- FC Flow Controls
- PC Pressure Controls
- LE Logic Elements
- DC Directional Controls
- MV Manual Valves
- SV Solenoid Valves
- PV Proportional Valves
- CE Coils & Electronics
- BC Bodies & Cavities
- TD Technical Data

Restrictive Flow Regulator:

Normally open spool type logic elements can be used with an external orifice or valve as a compensator to regulate flow. Used as restrictive compensator, a normally open spool senses the upstream and downstream pressure across an orifice or valve. The spool modulates closed to maintain a constant pressure drop across the controlled device equal to the bias spring in the logic valve, thus maintaining a constant flow rate regardless of changes in upstream or downstream pressure.

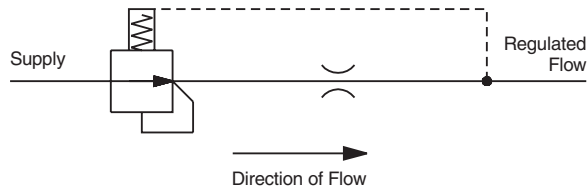

Priority / Bypass Flow Regulator:

A logic valve with a normally closed spool can be used as a priority or by-pass compensator. In this case, the spool modulates open to maintain a constant pressure drop across the controlled orifice or valve, thereby maintaining a constant priority flow regardless of upstream or downstream pressure changes. In a priority arrangement, any oil that doesn't saturate the controlled device is by-passed at load pressure plus the value of the bias spring in the logic valve.

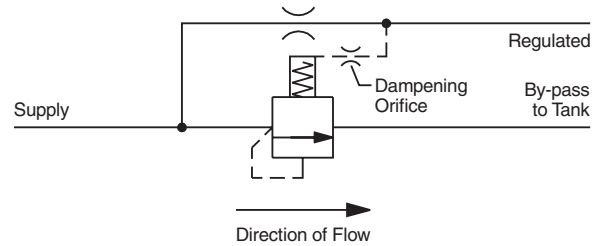

Pressure Control:

Spool type logic valves can be used as the main stage spool in high flow pressure control applications with the logic valve handling the high flow, and a small pilot valve controlling the action of the logic valve spool. Normally open, and normally closed spool options are available enabling virtually all pressure control functions to be achieved. When used in pressure control applications, the logic valve spool modulates open or closed to maintain the pressure setting of the pilot valve communicated to port 3. Pressure control applications require a pilot connection between the control port (port 1 or 2), and the pilot port (port 3). In order to simplify the design, Parker offers spool type logic valves with internal piloting options that can help minimize the number of connections needed. When used in manifold systems, the internal piloting options help to simplify the manifold design by reducing the number of construction drillings in the block. Multiple functions such as relief, pump unloading, and pressure compensation can be performed with one logic valve by communicating multiple pilot devices to the same logic element.

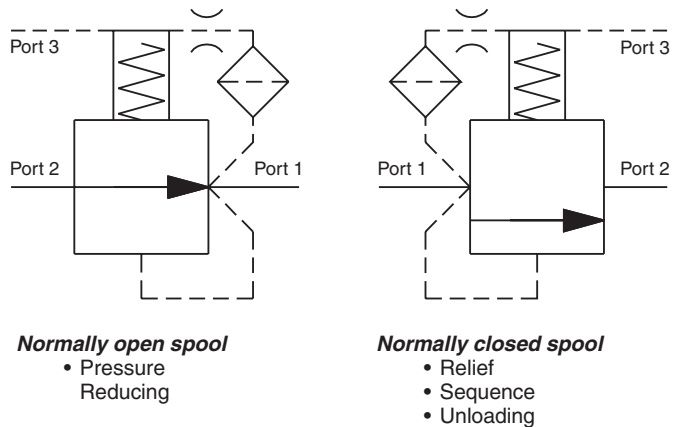

(See circuit examples on page LE6)

Application Note:

This section is as an application guide, and it is intended to illustrate the various ways that logic elements can be used to create a variety of hydraulic control functions. For additional help applying logic valves, contact your Parker Sales Engineer.

DIRECTIONAL CONTROL EXAMPLES

2-position, 2-way normally open example.

Switched by 2-position, 3-way pilot valve and external pilot pressure.

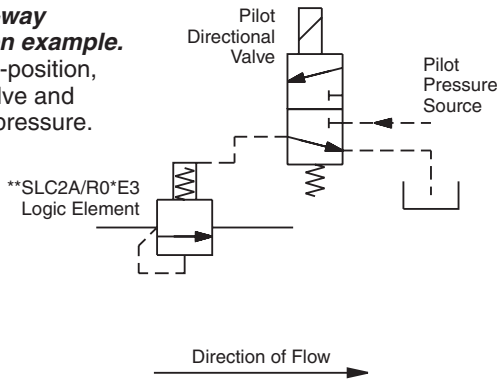

2-position, 2-way normally open example.

Switched by external pilot pressure and vented through 2-position, 2-way pilot valve.

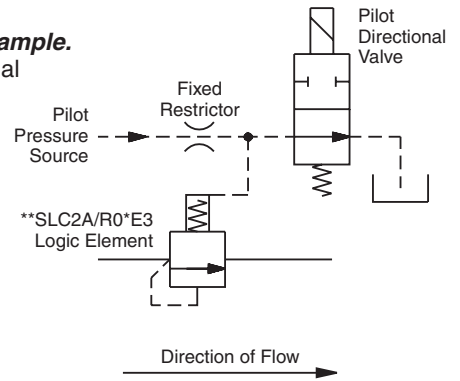

2-position, 2-way normally open example.

Internal pilot generation.

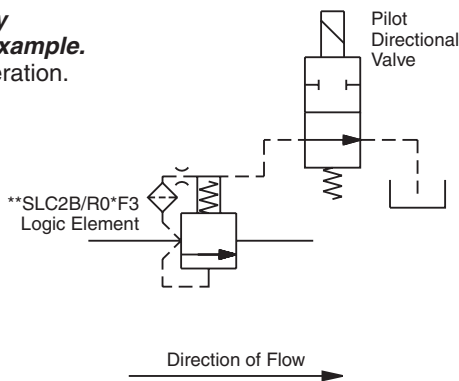

2-position, 2-way normally open example.

Internal pilot generation.

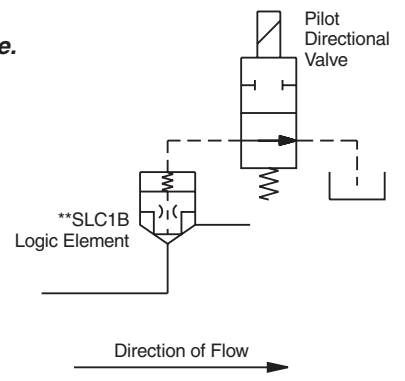

2-position, 2-way normally open example.

Internal pilot generation.

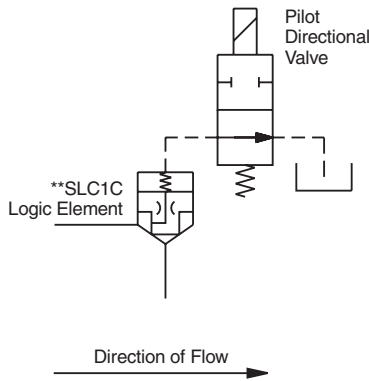

2-position, 2-way normally open example.

Switched by 2-position, 3-way pilot valve and external pilot.

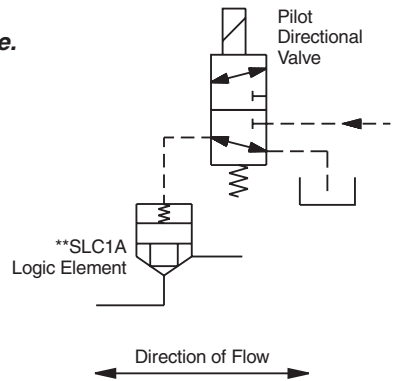

****SLC1A logic element.**

With shuttle-selected pilot supply.

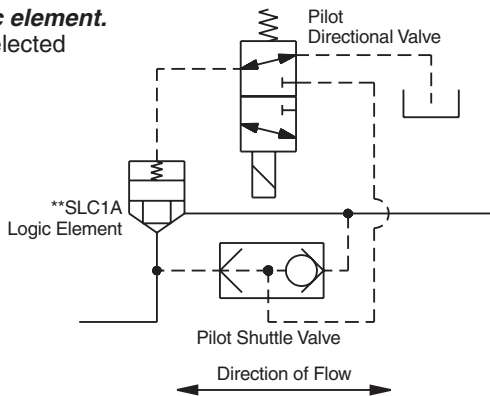

****SLC1A logic element.**

External pilot supply and 2-position, 2-way pilot directional valve.

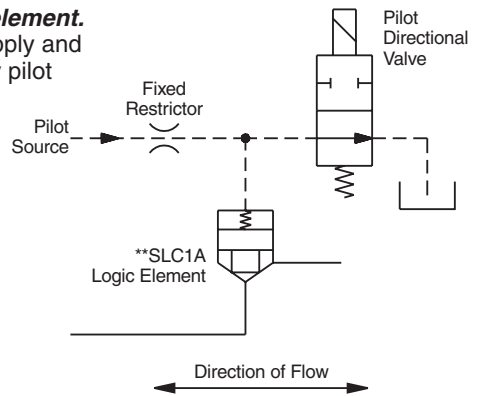

CV
Check Valves
SH
Shuttle Valves
LM
Load/Motor Controls
FC
Flow Controls
PC
Pressure Controls
LE
Logic Elements
DC
Directional Controls
MV
Manual Valves
SV
Solenoid Valves
PV
Proportional Valves
CE
Coils & Electronics
BC
Bodies & Cavities
TD
Technical Data

DIRECTIONAL CONTROL EXAMPLES

THREE-WAY BRIDGE CIRCUITS

*Circuit 1, with **SLC1A poppet logic element.*

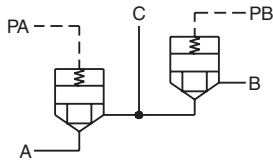

*Circuit 2, with **SLC2A/R0*E3 spool logic element.*

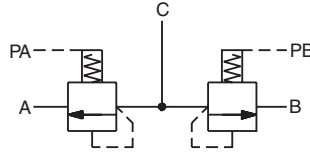

*Circuit 3, with **SLC2A/R0*E3 spool logic element.*

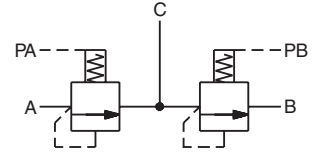

Required Flow Path	Pilot Pressure Applied To		Available From Circuit			Required Flow Path	Pilot Pressure Applied To		Available From Circuit		
	PA	PB	1	2	3		PA	PB	1	2	3
	NO	NO	X	X			NO	YES	X	X	
	YES	NO	X	X	X		NO	YES	X		X

NOTE: Pilot pressure must exceed load pressure in order for valve to close.

FOUR-WAY BRIDGE CIRCUITS

*Circuit 1, with **SLC1A poppet logic elements.*

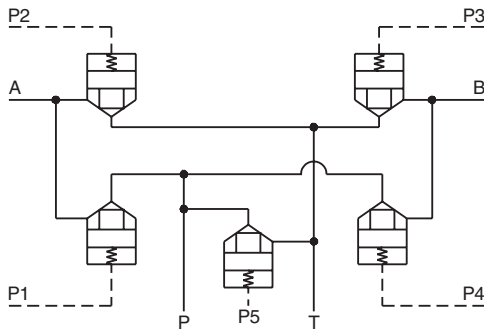

*Circuit 2, with **SLC2A/R0*E3 spool logic elements.*

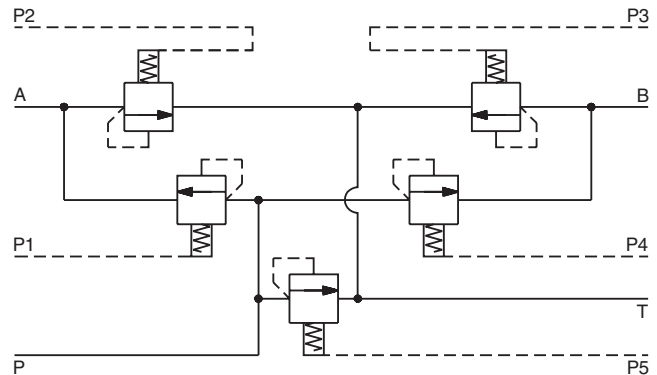

Required Flow Path	Pilot Pressure Applied To					Required Flow Path	Pilot Pressure Applied To					Required Flow Path	Pilot Pressure Applied To				
	P1	P2	P3	P4	P5		P1	P2	P3	P4	P5		P1	P2	P3	P4	P5
	YES	YES	YES	YES	YES		YES	NO	NO	YES	YES		YES	NO	YES	NO	YES
	NO	NO	NO	NO	NO		NO	YES	YES	NO	YES		YES	YES	YES	NO	YES
	YES	YES	NO	NO	NO		YES	YES	NO	YES	YES		YES	NO	YES	YES	YES
	NO	NO	YES	YES	NO		NO	YES	YES	YES	YES						
	YES	YES	YES	YES	NO		NO	YES	NO	YES	YES						

NOTE: Pilot pressure must exceed load pressure in order for valve to close.

- CV** Check Valves
- SH** Shuttle Valves
- LM** Load/Motor Controls
- FC** Flow Controls
- PC** Pressure Controls
- LE** Logic Elements
- DC** Directional Controls
- MV** Manual Valves
- SV** Solenoid Valves
- PV** Proportional Valves
- CE** Coils & Electronics
- BC** Bodies & Cavities
- TD** Technical Data

FLOW CONTROL EXAMPLES

Pressure compensated priority flow control example.

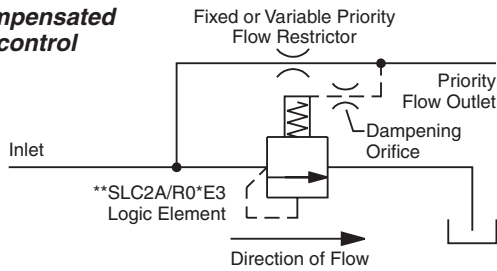

Pressure compensated restrictive flow control example.

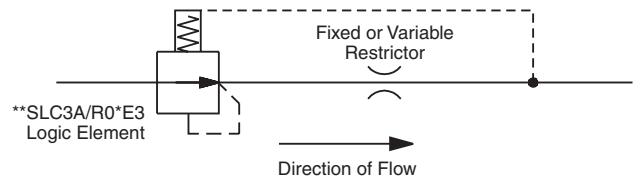

Load sensing priority flow control example with pressure limiting and unloading.

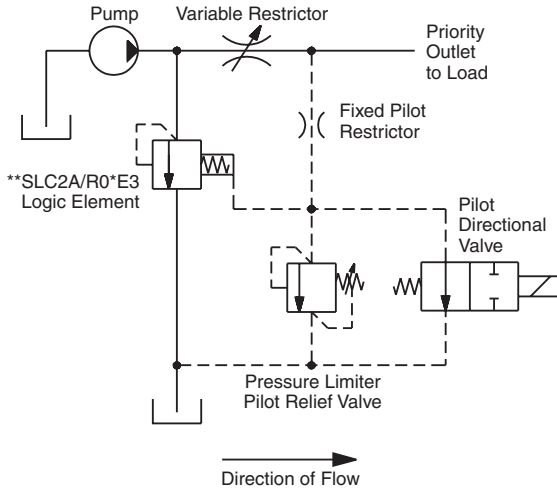

Load sensing priority flow control example with pressure limiter.

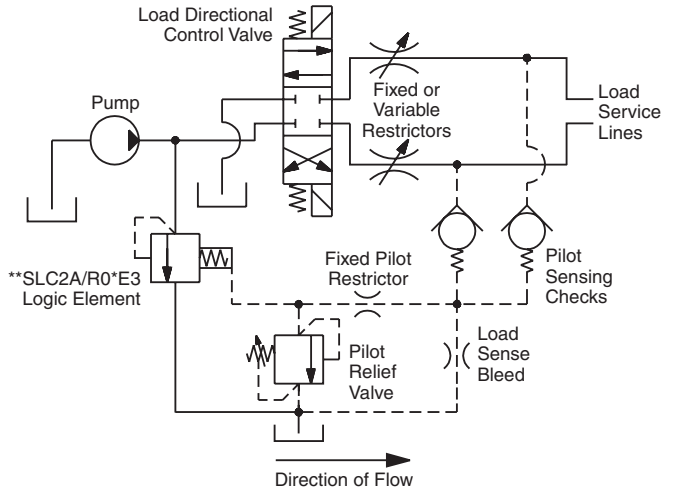

PRESSURE CONTROL EXAMPLES

Pressure relief or sequence example with external pilot supply and pilot relief.

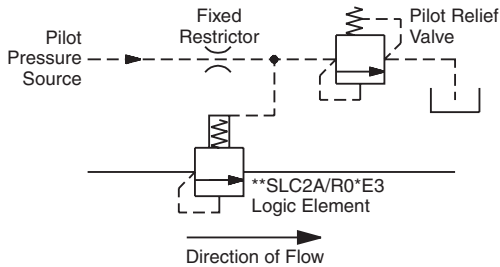

Pressure relief or sequence example with internal pilot supply and pilot relief.

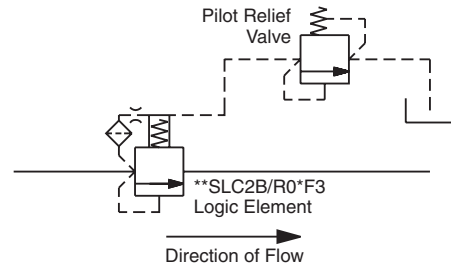

Pressure reducing example, non-relieving type.

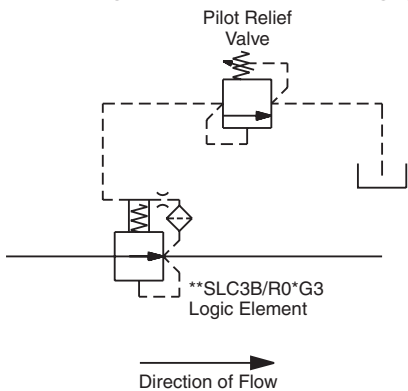

Pressure reducing-relieving example.

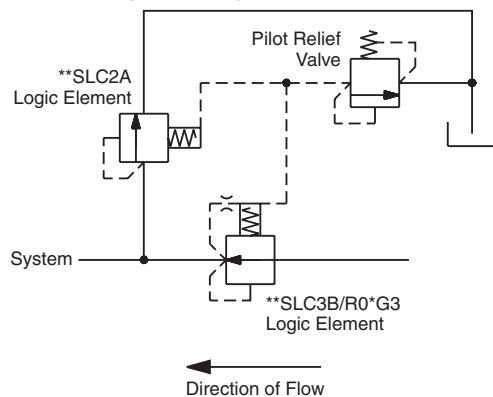

CV
Check Valves
SH
Shuttle Valves
LM
Load/Motor Controls
FC
Flow Controls
PC
Pressure Controls
LE
Logic Elements
DC
Directional Controls
MV
Manual Valves
SV
Solenoid Valves
PV
Proportional Valves
CE
Coils & Electronics
BC
Bodies & Cavities
TD
Technical Data

Technical Information

- CV** Check Valves
- SH** Shuttle Valves
- LM** Load/Motor Controls
- FC** Flow Controls
- PC** Pressure Controls
- LE** Logic Elements
- DC** Directional Controls
- MV** Manual Valves
- SV** Solenoid Valves
- PV** Proportional Valves
- CE** Coils & Electronics
- BC** Bodies & Cavities
- TD** Technical Data

General Description

Poppet Type, Bi-Directional, Normally Closed, Pilot to Close Logic Element. For additional information see Technical Tips on pages LE1-LE6.

Features

- Hardened, precision ground parts for durability
- Polyurethane seals only
- No backup rings
- Low leakage design
- All external parts zinc plated

Performance Curve

Pressure Drop vs. Flow (Through cartridge only)

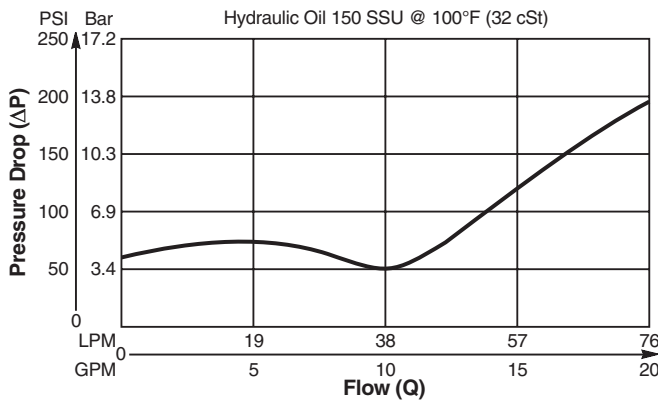

Specifications

Rated Flow	57 LPM (15 GPM)
Maximum Inlet Pressure	240 Bar (3500 PSI)
Leakage @ 150 SSU (32 cst)	Port 1 to 2 5 drops/min. (.33 cc/min.) @ 240 Bar (3500 PSI)
Cartridge Material	All parts steel. All operating parts hardened steel.
Operating Temp. Range/Seals	-45°C to +93.3°C (Polyurethane) (-50°F to +200°F)
Fluid Compatibility/Viscosity	Mineral-based or synthetic with lubricating properties at viscosities of 45 to 2000 SSU (6 to 420 cSt)
Filtration	ISO Code 16/13, SAE Class 4 or better
Approx. Weight	.14 kg (.30 lbs.)
Cavity	C10-3S (See BC Section for more details)
Form Tool	Rougher NFT10-3SR Finisher NFT10-3SF

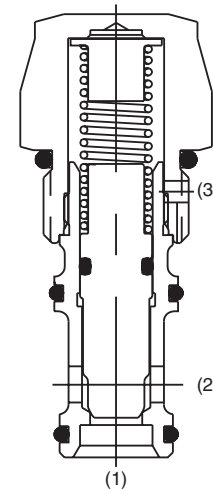
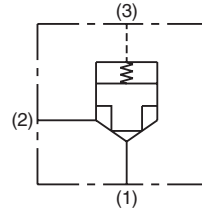

Dimensions Millimeters (Inches)

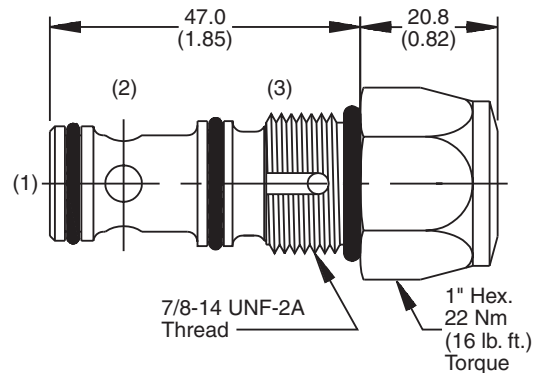

Ordering Information

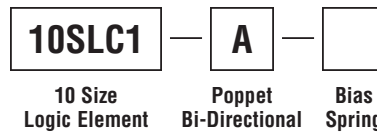

Code	Bias Spring
50	3.5 Bar (50 PSI)
75	5.2 Bar (75 PSI)
100	6.9 Bar (100 PSI)
150	10.3 Bar (150 PSI)

Seal Kit
WRK-10-3S

General Description

Poppet Type, Bi-Directional, Normally Closed, Pilot to Close Logic Element. For additional information see Technical Tips on pages LE1-LE6.

Features

- Hardened, precision ground parts for durability
- Polyurethane seals only
- No backup rings
- Low leakage design
- All external parts zinc plated

Performance Curve

Pressure Drop vs. Flow (Through cartridge only)

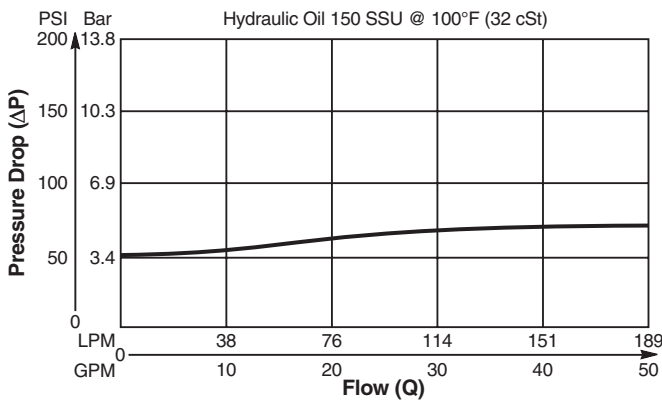

Specifications

Rated Flow	189 LPM (50 GPM)
Maximum Inlet Pressure	240 Bar (3500 PSI)
Leakage @ 150 SSU (32 cst)	Port 1 to 2 5 drops/min. (.33 cc/min.) @ 240 Bar (3500 PSI)
Cartridge Material	All parts steel. All operating parts hardened steel.
Operating Temp. Range/Seals	-45°C to +93.3°C (Polyurethane) (-50°F to +200°F)
Fluid Compatibility/ Viscosity	Mineral-based or synthetic with lubricating properties at viscosities of 45 to 2000 SSU (6 to 420 cSt)
Filtration	ISO Code 16/13, SAE Class 4 or better
Approx. Weight	.33 kg (.78 lbs.)
Cavity	C16-3S (See BC Section for more details)
Form Tool	Rougher NFT16-3SR Finisher NFT16-3SF

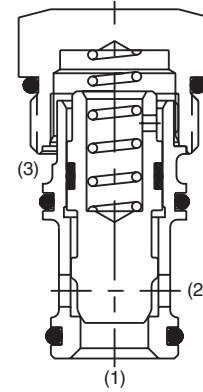
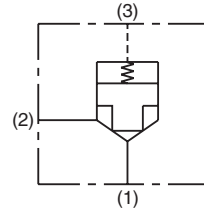

Dimensions Millimeters (Inches)

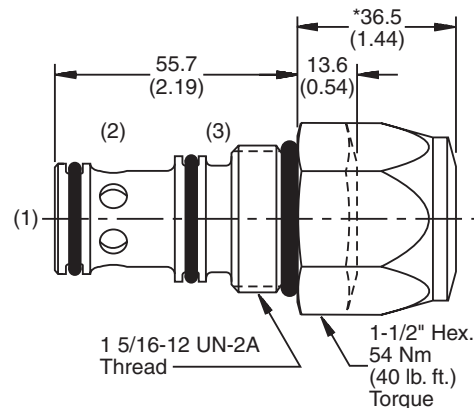

Ordering Information

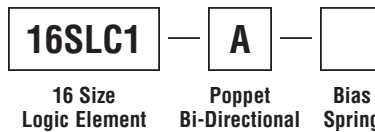

Code	Bias Spring
50	3.5 Bar (50 PSI)
75	5.2 Bar (75 PSI)
*100	6.9 Bar (100 PSI)
*150	10.3 Bar (150 PSI)

*Indicates larger cap height, see drawing.

Seal Kit
WRK-16-3S

- CV** Check Valves
- SH** Shuttle Valves
- LM** Load/Motor Controls
- FC** Flow Controls
- PC** Pressure Controls
- LE** Logic Elements
- DC** Directional Controls
- MV** Manual Valves
- SV** Solenoid Valves
- PV** Proportional Valves
- CE** Coils & Electronics
- BC** Bodies & Cavities
- TD** Technical Data

Technical Information

- CV** Check Valves
- SH** Shuttle Valves
- LM** Load/Motor Controls
- FC** Flow Controls
- PC** Pressure Controls
- LE** Logic Elements
- DC** Directional Controls
- MV** Manual Valves
- SV** Solenoid Valves
- PV** Proportional Valves
- CE** Coils & Electronics
- BC** Bodies & Cavities
- TD** Technical Data

General Description

Poppet Type, Bi-Directional, Normally Closed, Pilot to Close Logic Element. For additional information see Technical Tips on pages LE1-LE6.

Features

- Hardened, precision ground parts for durability
- Polyurethane seals only
- No backup rings
- Low leakage design
- All external parts zinc plated

Performance Curve

Pressure Drop vs. Flow (Through cartridge only)

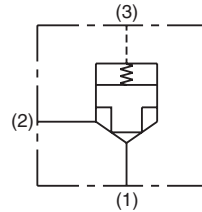
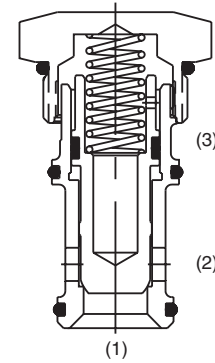
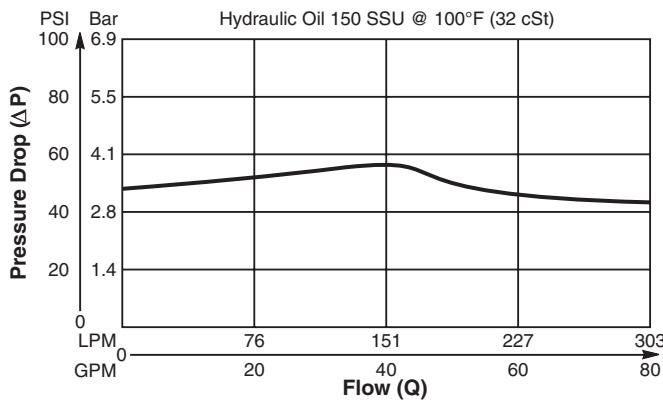

Dimensions Millimeters (Inches)

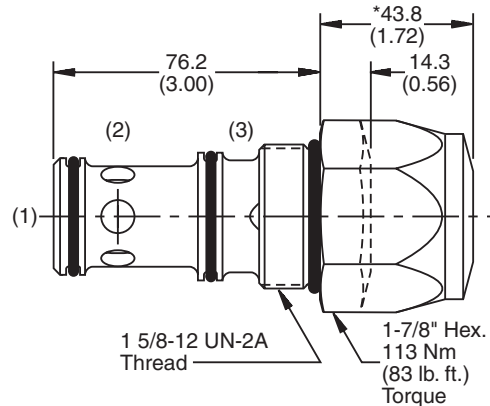

Specifications

Rated Flow	303 LPM (80 GPM)
Maximum Inlet Pressure	240 Bar (3500 PSI)
Leakage @ 150 SSU (32 cst)	Port 1 to 2 5 drops/min. (.33 cc/min.) @ 240 Bar (3500 PSI)
Cartridge Material	All parts steel. All operating parts hardened steel.
Operating Temp. Range/Seals	-45°C to +93.3°C (Polyurethane) (-50°F to +200°F)
Fluid Compatibility/Viscosity	Mineral-based or synthetic with lubricating properties at viscosities of 45 to 2000 SSU (6 to 420 cSt)
Filtration	ISO Code 16/13, SAE Class 4 or better
Approx. Weight	.81 kg (1.78 lbs.)
Cavity	C20-3S (See BC Section for more details)
Form Tool	Rougher NFT20-3SR Finisher NFT20-3SF

Ordering Information

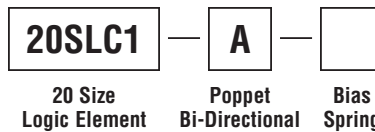

Code	Bias Spring
50	3.5 Bar (50 PSI)
*75	5.2 Bar (75 PSI)
*100	6.9 Bar (100 PSI)
*150	10.3 Bar (150 PSI)

*Indicates larger cap height, see drawing.

Seal Kit
WRK-20-3S

General Description

Poppet Type , Normally Closed, Vent to Open Logic Element. Generation port is from 2 to 3. For additional information see Technical Tips on pages LE1-LE6.

Features

- Hardened, precision ground parts for durability
- Polyurethane seals only
- No backup rings
- Low leakage design
- All external parts zinc plated

Performance Curve

Pressure Drop vs. Flow (Through cartridge only)

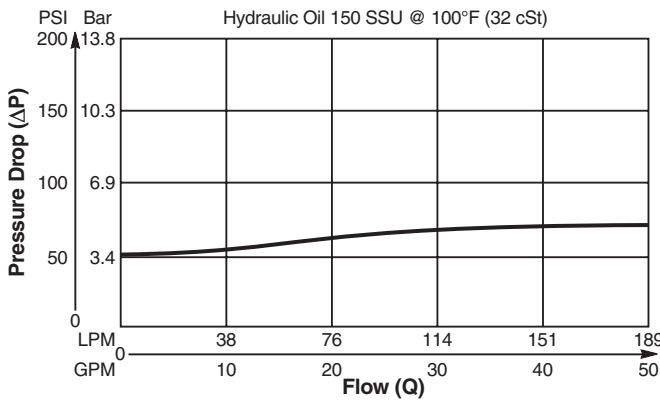

Specifications

Rated Flow	189 LPM (50 GPM)
Maximum Inlet Pressure	240 Bar (3500 PSI)
Leakage @ 150 SSU (32 cst)	Port 1 to 2 5 drops/min. (.33 cc/min.) @ 240 Bar (3500 PSI)
Cartridge Material	All parts steel. All operating parts hardened steel.
Operating Temp. Range/Seals	-45°C to +93.3°C (Polyurethane) (-50°F to +200°F)
Fluid Compatibility/ Viscosity	Mineral-based or synthetic with lubricating properties at viscosities of 45 to 2000 SSU (6 to 420 cSt)
Filtration	ISO Code 16/13, SAE Class 4 or better
Approx. Weight	.33 kg (.78 lbs.)
Cavity	C16-3S (See BC Section for more details)
Form Tool	Rougher NFT16-3SR Finisher NFT16-3SF

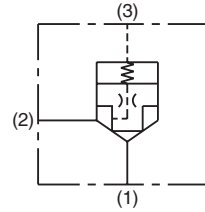
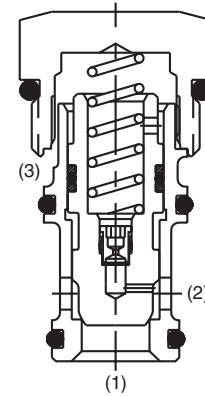

Dimensions Millimeters (Inches)

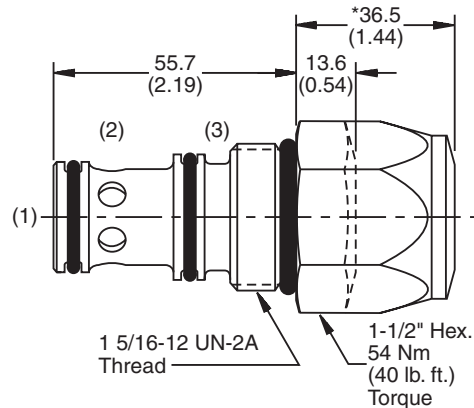

Ordering Information

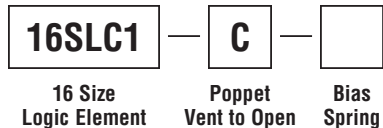

Code	Bias Spring
50	3.5 Bar (50 PSI)
75	5.2 Bar (75 PSI)
*100	6.9 Bar (100 PSI)
*150	10.3 Bar (150 PSI)

*Indicates larger cap height, see drawing.

Seal Kit
WRK-16-3S

- CV**
- Check Valves
- SH**
- Shuttle Valves
- LM**
- Load/Motor Controls
- FC**
- Flow Controls
- PC**
- Pressure Controls
- LE**
- Logic Elements
- DC**
- Directional Controls
- MV**
- Manual Valves
- SV**
- Solenoid Valves
- PV**
- Proportional Valves
- CE**
- Coils & Electronics
- BC**
- Bodies & Cavities
- TD**
- Technical Data

Technical Information

- CV** Check Valves
- SH** Shuttle Valves
- LM** Load/Motor Controls
- FC** Flow Controls
- PC** Pressure Controls
- LE** Logic Elements
- DC** Directional Controls
- MV** Manual Valves
- SV** Solenoid Valves
- PV** Proportional Valves
- CE** Coils & Electronics
- BC** Bodies & Cavities
- TD** Technical Data

General Description

Spool Type, Normally Closed, Pilot to Close Logic Element. For additional information see Technical Tips on pages LE1-LE6.

Features

- Hardened, precision ground parts for durability
- Polyurethane seals only
- No backup rings
- All external parts zinc plated

Performance Curve

Pressure Drop vs. Flow (Through cartridge only)

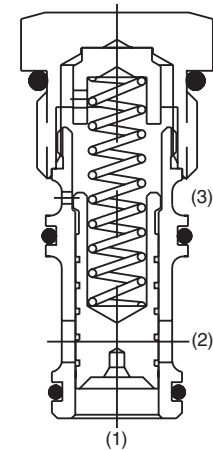
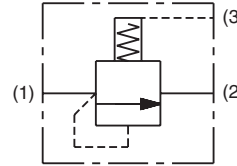
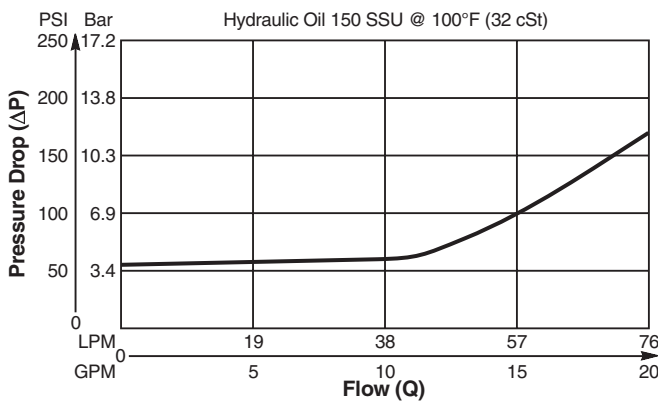

Dimensions Millimeters (Inches)

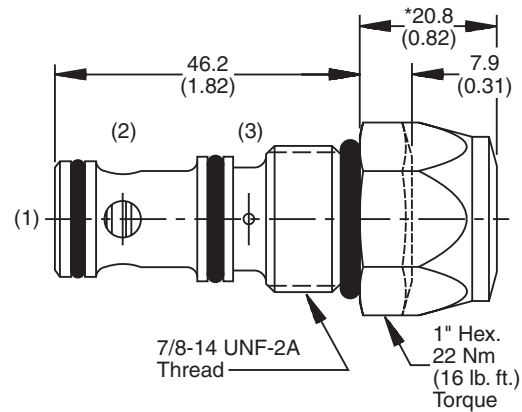

Specifications

Rated Flow	57 LPM (15 GPM)
Maximum Inlet Pressure	240 Bar (3500 PSI)
Leakage @ 150 SSU (32 cst)	Port 1 to 2 82 cc/min. (5 in ³ /min.) @ 240 Bar (3500 PSI)
Cartridge Material	All parts steel. All operating parts hardened steel.
Operating Temp. Range/Seals	-45°C to +93.3°C (Polyurethane) (-50°F to +200°F)
Fluid Compatibility/Viscosity	Mineral-based or synthetic with lubricating properties at viscosities of 45 to 2000 SSU (6 to 420 cSt)
Filtration	ISO Code 16/13, SAE Class 4 or better
Approx. Weight	.14 kg (.30 lbs.)
Cavity	C10-3S (See BC Section for more details)
Form Tool	Rougher NFT10-3SR Finisher NFT10-3SF

Ordering Information

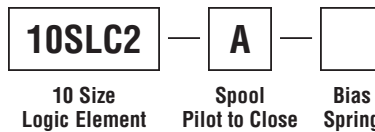

Code	Bias Spring
25	1.7 Bar (25 PSI)
50	3.5 Bar (50 PSI)
75	5.2 Bar (75 PSI)
*100	6.9 Bar (100 PSI)
*150	10.3 Bar (150 PSI)

*Indicates larger cap height, see drawing.

Seal Kit
WRK-10-3S

General Description

Spool Type , Normally Closed, Pilot to Close Logic Element. For additional information see Technical Tips on pages LE1-LE6.

Features

- Hardened, precision ground parts for durability
- Polyurethane seals only
- No backup rings
- All external parts zinc plated

Performance Curve

Pressure Drop vs. Flow (Through cartridge only)

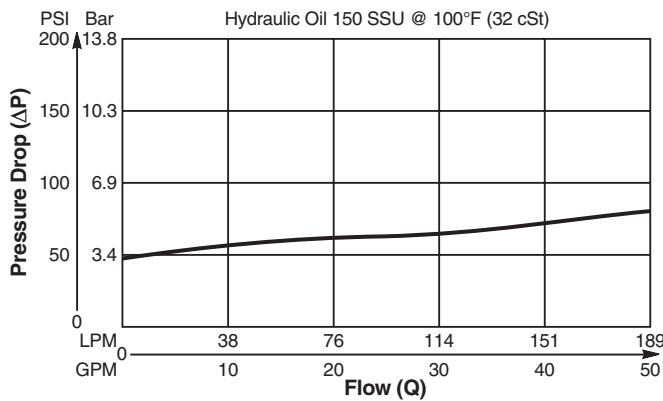

Specifications

Rated Flow	189 LPM (50 GPM)
Maximum Inlet Pressure	240 Bar (3500 PSI)
Leakage @ 150 SSU (32 cst)	Port 1 to 2 82 cc/min. (5 in ³ /min.) @ 240 Bar (3500 PSI)
Cartridge Material	All parts steel. All operating parts hardened steel.
Operating Temp. Range/Seals	-45°C to +93.3°C (Polyurethane) (-50°F to +200°F)
Fluid Compatibility/ Viscosity	Mineral-based or synthetic with lubricating properties at viscosities of 45 to 2000 SSU (6 to 420 cSt)
Filtration	ISO Code 16/13, SAE Class 4 or better
Approx. Weight	.33 kg (.78 lbs.)
Cavity	C16-3S (See BC Section for more details)
Form Tool	Rougher NFT16-3SR Finisher NFT16-3SF

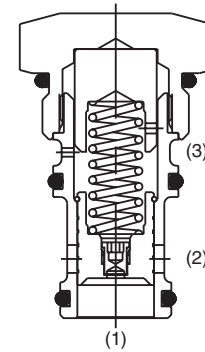
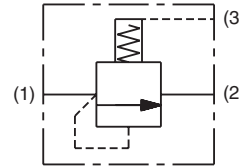

Dimensions Millimeters (Inches)

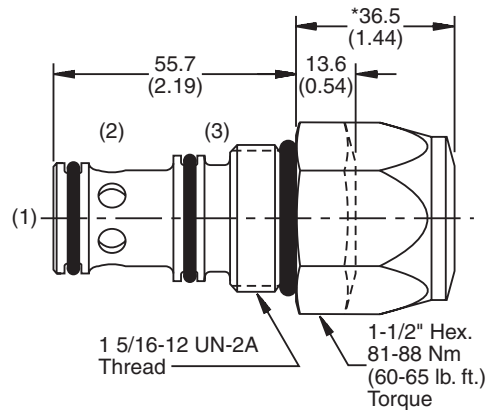

Ordering Information

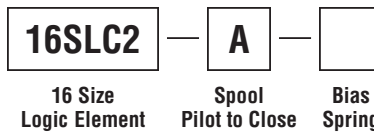

Code	Bias Spring
25	1.7 Bar (25 PSI)
50	3.5 Bar (50 PSI)
75	5.2 Bar (75 PSI)
*100	6.9 Bar (100 PSI)
*150	10.3 Bar (150 PSI)

*Indicates larger cap height, see drawing.

Seal Kit
WRK-16-3S

- CV** Check Valves
- SH** Shuttle Valves
- LM** Load/Motor Controls
- FC** Flow Controls
- PC** Pressure Controls
- LE** Logic Elements
- DC** Directional Controls
- MV** Manual Valves
- SV** Solenoid Valves
- PV** Proportional Valves
- CE** Coils & Electronics
- BC** Bodies & Cavities
- TD** Technical Data

Technical Information

- CV** Check Valves
- SH** Shuttle Valves
- LM** Load/Motor Controls
- FC** Flow Controls
- PC** Pressure Controls
- LE** Logic Elements
- DC** Directional Controls
- MV** Manual Valves
- SV** Solenoid Valves
- PV** Proportional Valves
- CE** Coils & Electronics
- BC** Bodies & Cavities
- TD** Technical Data

General Description

Spool Type, Normally Closed, Pilot to Close Logic Element. For additional information see Technical Tips on pages LE1-LE6.

Features

- Hardened, precision ground parts for durability
- Polyurethane seals only
- No backup rings
- All external parts zinc plated

Performance Curve

Pressure Drop vs. Flow (Through cartridge only)

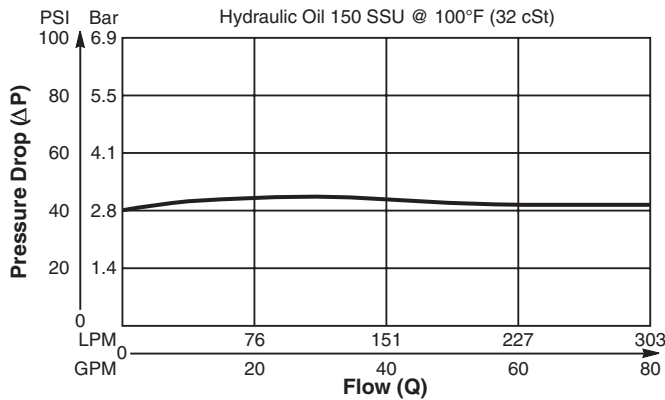

Specifications

Rated Flow	303 LPM (80 GPM)
Maximum Inlet Pressure	240 Bar (3500 PSI)
Leakage @ 150 SSU (32 cst)	Port 1 to 2 82 cc/min. (5 in ³ /min.) @ 240 Bar (3500 PSI)
Cartridge Material	All parts steel. All operating parts hardened steel.
Operating Temp. Range/Seals	-45°C to +93.3°C (Polyurethane) (-50°F to +200°F)
Fluid Compatibility/Viscosity	Mineral-based or synthetic with lubricating properties at viscosities of 45 to 2000 SSU (6 to 420 cSt)
Filtration	ISO Code 16/13, SAE Class 4 or better
Approx. Weight	.81 kg (1.78 lbs.)
Cavity	C20-3S (See BC Section for more details)
Form Tool	Rougher NFT20-3SR Finisher NFT20-3SF

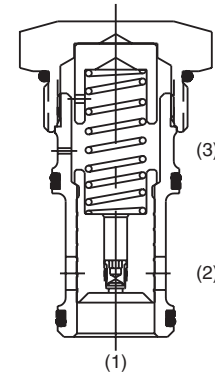
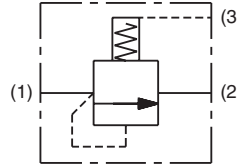

Dimensions Millimeters (Inches)

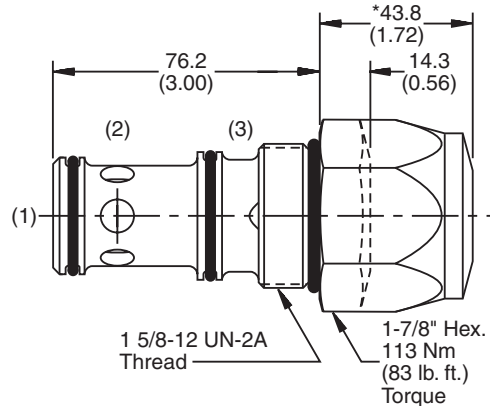

Ordering Information

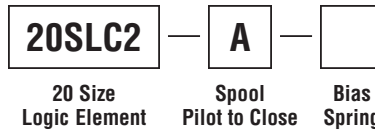

Code	Bias Spring
25	1.7 Bar (25 PSI)
50	3.5 Bar (50 PSI)
*75	5.2 Bar (75 PSI)
*100	6.9 Bar (100 PSI)
*150	10.3 Bar (150 PSI)

*Indicates larger cap height, see drawing.

Seal Kit
WRK-20-3S

General Description

Spool Type , Normally Closed, Pilot to Close Logic Element. For additional information see Technical Tips on pages LE1-LE6.

Features

- High flow capacity
- Used as high flow switching or metering element
- Can be used as bleed off style pressure compensated flow regulator when used with restrictor
- More stable than poppet type
- Various switching pressures available
- 1:1 pilot pressure ratio
- Hardened working parts for maximum durability
- All external parts zinc plated

Performance Curve (Through cartridge only)

Vented Open Pressure Drop vs. Flow 1 to 2

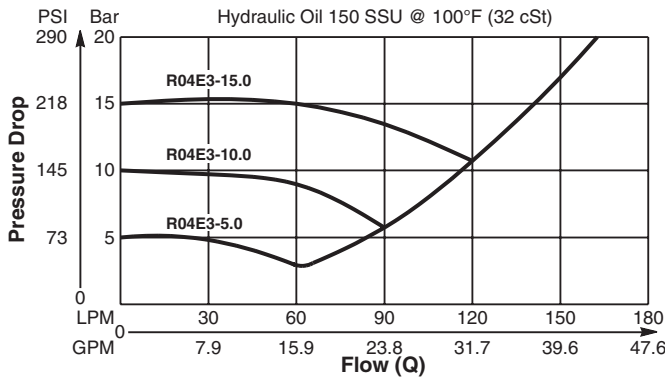

Specifications

Rated Flow	170 LPM (45 GPM)
Nominal Flow @ 7 Bar (100 PSI)	100 LPM (26 GPM)
Maximum Inlet Pressure	420 Bar (6000 PSI)
Leakage @ 150 SSU (32 cst)	50 ml/min. @ 100 Bar (1450 PSI)
Switching Press.	See ordering information
Cartridge Material	All parts steel. All operating parts hardened steel.
Operating Temp. Range/Seals	-40°C to +93.3°C (Nitrile) (-40°F to +200°F) -31.7°C to +121.1°C (Fluorocarbon) (-25°F to +250°F)
Fluid Compatibility/Viscosity	Mineral-based or synthetic with lubricating properties at viscosities of 45 to 2000 SSU (6 to 420 cSt)
Filtration	ISO Code 16/13, SAE Class 4 or better
Approx. Weight	.14 kg (.31 lbs.)
Cavity	C10-3S (See BC Section for more details)
Form Tool	Rougher NFT10-3SR Finisher NFT10-3SF

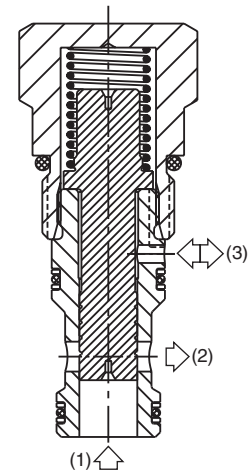
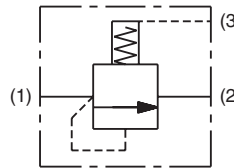

Dimensions Millimeters (Inches)

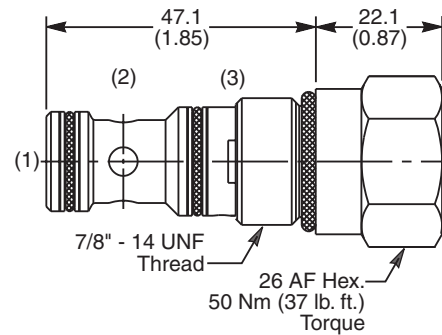

Ordering Information

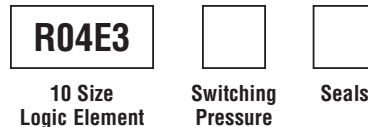

Code	Switching Pressure Non Adjustable Preset
1.0	1.0 Bar (14.5 PSI)
5.0	5.0 Bar (73 PSI) Std.
10.0	10.0 Bar (145 PSI)
15.0	15.0 Bar (218 PSI)
20.0	20.0 Bar (290 PSI)

Code	Seals / Kit. No.
N	Nitrile, Buna-N (Std.) / (SK30504N-1)
V	Fluorocarbon / (SK30504V-1)

If no switching pressure is specified, valve will be supplied as R04E3-5.0N

- CV Check Valves
- SH Shuttle Valves
- LM Load/Motor Controls
- FC Flow Controls
- PC Pressure Controls
- LE Logic Elements
- DC Directional Controls
- MV Manual Valves
- SV Solenoid Valves
- PV Proportional Valves
- CE Coils & Electronics
- BC Bodies & Cavities
- TD Technical Data

Technical Information

- CV** Check Valves
- SH** Shuttle Valves
- LM** Load/Motor Controls
- FC** Flow Controls
- PC** Pressure Controls
- LE** Logic Elements
- DC** Directional Controls
- MV** Manual Valves
- SV** Solenoid Valves
- PV** Proportional Valves
- CE** Coils & Electronics
- BC** Bodies & Cavities
- TD** Technical Data

General Description

Spool Type , Normally Closed, Pilot to Close Logic Element. For additional information see Technical Tips on pages LE1-LE6.

Features

- High flow capacity
- Used as high flow switching or metering element
- Can be used as bleed off style pressure compensated flow regulator when used with restrictor
- More stable than poppet type
- Various switching pressures available
- 1:1 pilot pressure ratio
- Hardened working parts for maximum durability
- All external parts zinc plated

Performance Curve (Through cartridge only)

Vented Open Pressure Drop vs. Flow 1 to 2

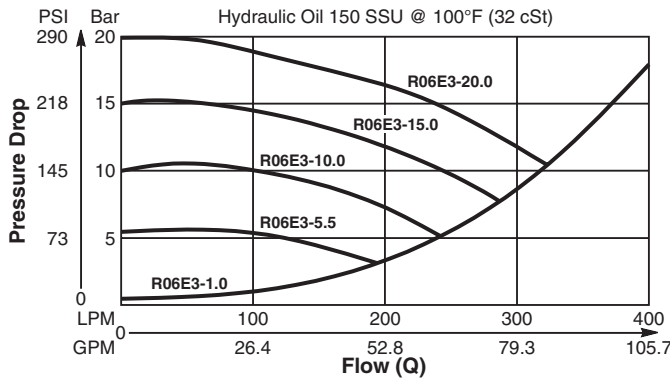

Specifications

Rated Flow	400 LPM (106 GPM)
Nominal Flow @ 7 Bar (100 PSI)	270 LPM (71 GPM)
Maximum Inlet Pressure	420 Bar (6000 PSI)
Leakage @ 150 SSU (32 cst)	90 ml/min. @ 100 Bar (1450 PSI)
Switching Press.	See ordering information
Cartridge Material	All parts steel. All operating parts hardened steel.
Operating Temp. Range/Seals	-40°C to +93.3°C (Nitrile) (-40°F to +200°F) -31.7°C to +121.1°C (Fluorocarbon) (-25°F to +250°F)
Fluid Compatibility/Viscosity	Mineral-based or synthetic with lubricating properties at viscosities of 45 to 2000 SSU (6 to 420 cSt)
Filtration	ISO Code 16/13, SAE Class 4 or better
Approx. Weight	.38 kg (.84 lbs.)
Cavity	C16-3S (See BC Section for more details)
Form Tool	Rougher NFT16-3SR Finisher NFT16-3SF

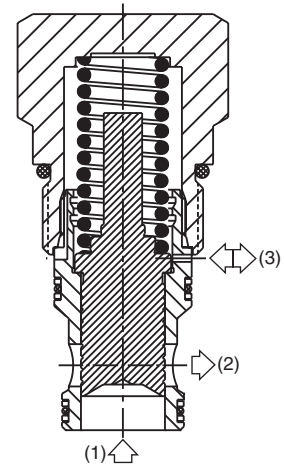
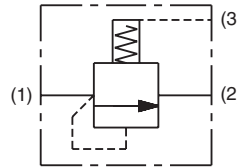
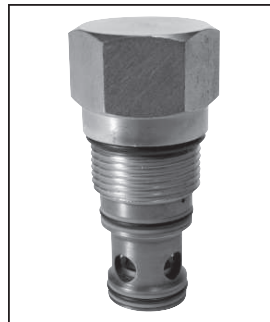

Dimensions Millimeters (Inches)

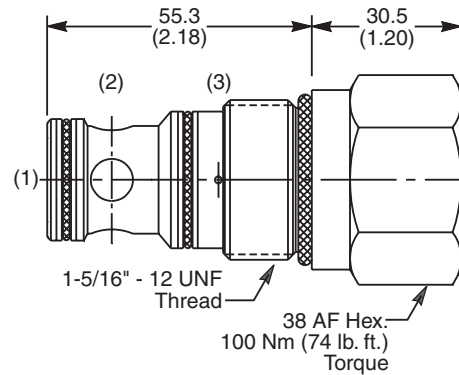

Ordering Information

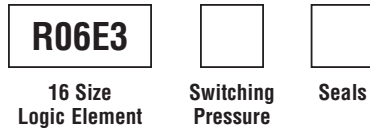

Code	Switching Pressure Non Adjustable Preset
1.0	1.0 Bar (14.5 PSI)
5.5	5.5 Bar (80 PSI) Std.
10.0	10.0 Bar (145 PSI)
15.0	15.0 Bar (218 PSI)
20.0	20.0 Bar (290 PSI)

Code	Seals / Kit. No.
N	Nitrile, Buna-N (Std.) / (SK30508N-1)
V	Fluorocarbon / (SK30508V-1)

If no switching pressure is specified, valve will be supplied as R06E3-5.5N

General Description

Spool Type , Normally Closed, Pilot to Close Logic Element. For additional information see Technical Tips on pages LE1-LE6.

Features

- High flow capacity
- Can be used as high flow switching or metering element
- Can be used as bleed off style pressure compensated flow regulator when used with restrictor
- Various switching pressures available
- 1:1 pilot pressure ratio
- Hardened working parts for maximum durability
- All external parts zinc plated

Performance Curve (Through cartridge only)
Vented Open Pressure Drop vs. Flow 1 to 2

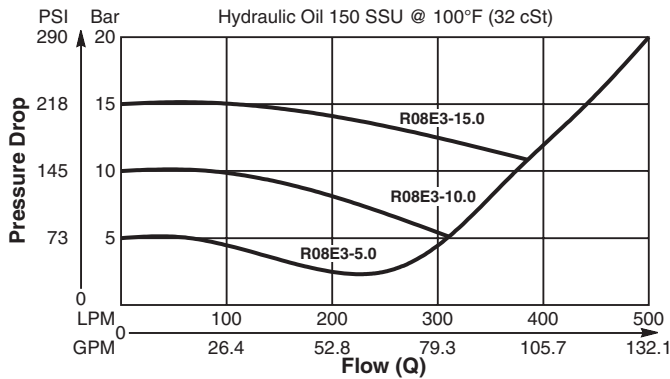

Specifications

Rated Flow	500 LPM (132 GPM)
Nominal Flow @ 7 Bar (100 PSI)	340 LPM (90 GPM)
Maximum Inlet Pressure	420 Bar (6000 PSI)
Leakage @ 150 SSU (32 cst)	90 ml/min. @ 100 Bar (1450 PSI)
Switching Press.	See ordering information
Cartridge Material	All parts steel. All operating parts hardened steel.
Operating Temp. Range/Seals	-40°C to +93.3°C (Nitrile) (-40°F to +200°F) -31.7°C to +121.1°C (Fluorocarbon) (-25°F to +250°F)
Fluid Compatibility/ Viscosity	Mineral-based or synthetic with lubricating properties at viscosities of 45 to 2000 SSU (6 to 420 cSt)
Filtration	ISO Code 16/13, SAE Class 4 or better
Approx. Weight	.69 kg (1.52 lbs.)
Cavity	C20-3S (See BC Section for more details)
Form Tool	Rougher NFT20-3SR Finisher NFT20-3SF

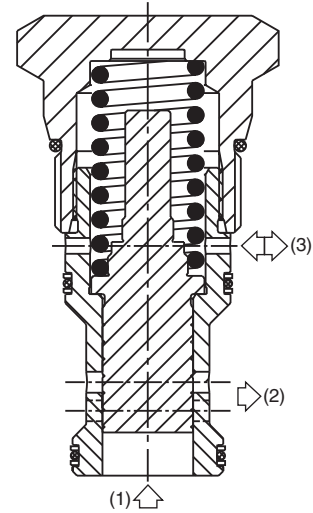
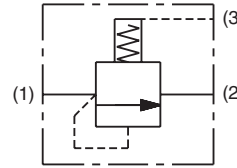
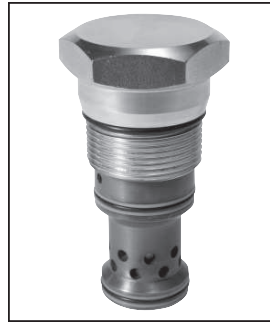

Dimensions Millimeters (Inches)

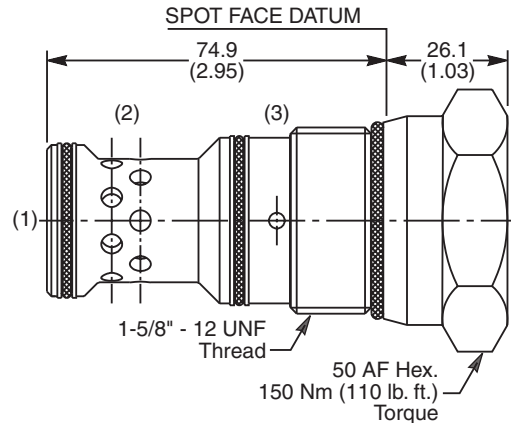

Ordering Information

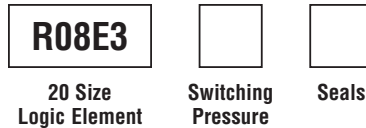

Code	Switching Pressure Non Adjustable Preset
5.5	5.5 Bar (80 PSI) Std.
10.0	10.0 Bar (145 PSI)
15.0	15.0 Bar (218 PSI)
20.0	20.0 Bar (290 PSI)

Code	Seals / Kit. No.
N	Nitrile, Buna-N (Std.) / (SK30512N-1)
V	Fluorocarbon / (SK30512V-1)

If no switching pressure is specified, valve will be supplied as R06E3-5.5N

- CV** Check Valves
- SH** Shuttle Valves
- LM** Load/Motor Controls
- FC** Flow Controls
- PC** Pressure Controls
- LE** Logic Elements
- DC** Directional Controls
- MV** Manual Valves
- SV** Solenoid Valves
- PV** Proportional Valves
- CE** Coils & Electronics
- BC** Bodies & Cavities
- TD** Technical Data

Technical Information

- CV** Check Valves
- SH** Shuttle Valves
- LM** Load/Motor Controls
- FC** Flow Controls
- PC** Pressure Controls
- LE** Logic Elements
- DC** Directional Controls
- MV** Manual Valves
- SV** Solenoid Valves
- PV** Proportional Valves
- CE** Coils & Electronics
- BC** Bodies & Cavities
- TD** Technical Data

General Description

Spool Type, Normally Closed, Vent to Open Logic Element. For additional information see Technical Tips on pages LE1-LE6.

Features

- Hardened, precision ground parts for durability
- Polyurethane seals only
- No backup rings
- All external parts zinc plated

Performance Curve

Pressure Drop vs. Flow (Through cartridge only)

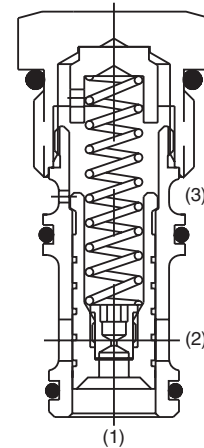
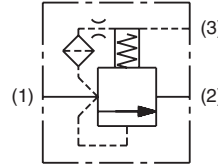
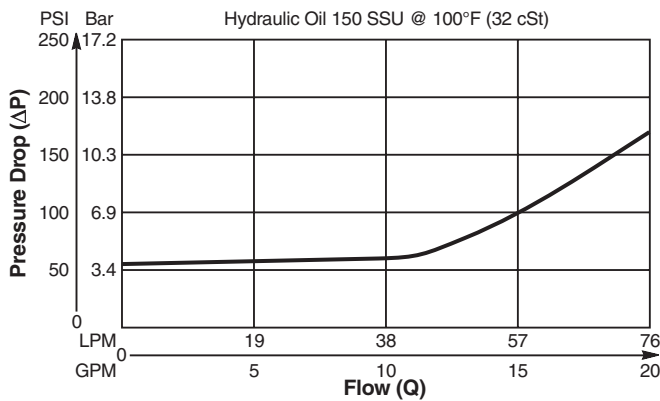

Dimensions Millimeters (Inches)

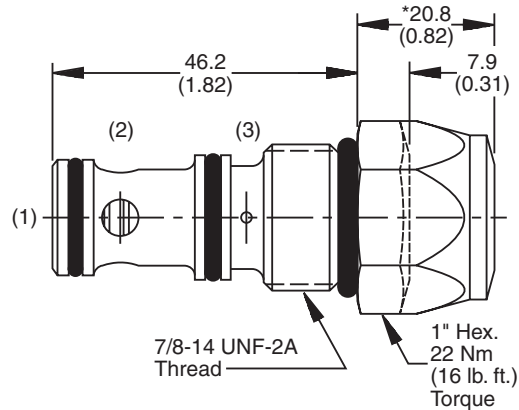

Specifications

Rated Flow	57 LPM (15 GPM)
Maximum Inlet Pressure	240 Bar (3500 PSI)
Leakage @ 150 SSu (32 cst)	Port 1 to 2 82 cc/min. (5 in ³ /min.) @ 240 Bar (3500 PSI)
Cartridge Material	All parts steel. All operating parts hardened steel.
Operating Temp. Range/Seals	-45°C to +93.3°C (Polyurethane) (-50°F to +200°F)
Fluid Compatibility/Viscosity	Mineral-based or synthetic with lubricating properties at viscosities of 45 to 2000 SSU (6 to 420 cSt)
Filtration	ISO Code 16/13, SAE Class 4 or better
Approx. Weight	.14 kg (.30 lbs.)
Cavity	C10-3S (See BC Section for more details)
Form Tool	Rougher NFT10-3SR Finisher NFT10-3SF

Ordering Information

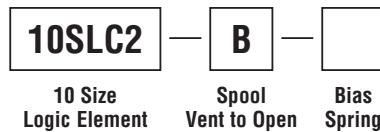

Code	Bias Spring
25	1.7 Bar (25 PSI)
50	3.5 Bar (50 PSI)
75	5.2 Bar (75 PSI)
*100	6.9 Bar (100 PSI)
*150	10.3 Bar (150 PSI)

*Indicates larger cap height, see drawing.

Seal Kit
WRK-10-3S

Technical Information

General Description

Spool Type , Normally Closed, Vent to Open Logic Element. For additional information see Technical Tips on pages LE1-LE6.

Features

- Hardened, precision ground parts for durability
- Polyurethane seals only
- No backup rings
- All external parts zinc plated

Performance Curve

Pressure Drop vs. Flow (Through cartridge only)

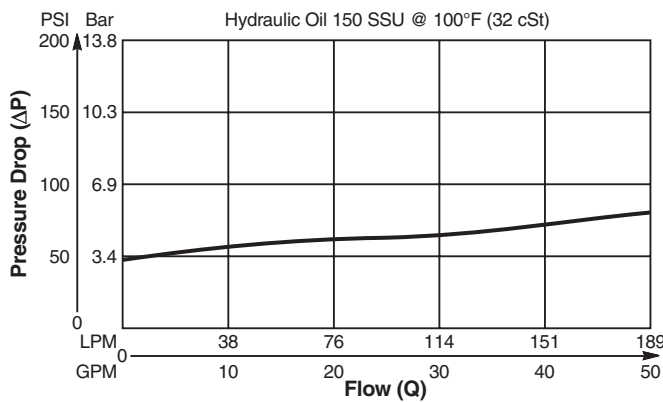

Specifications

Rated Flow	189 LPM (50 GPM)
Maximum Inlet Pressure	240 Bar (3500 PSI)
Leakage @ 150 SSU (32 cst)	Port 1 to 2 82 cc/min. (5 in ³ /min.) @ 240 Bar (3500 PSI)
Cartridge Material	All parts steel. All operating parts hardened steel.
Operating Temp. Range/Seals	-45°C to +93.3°C (Polyurethane) (-50°F to +200°F)
Fluid Compatibility/ Viscosity	Mineral-based or synthetic with lubricating properties at viscosities of 45 to 2000 SSU (6 to 420 cSt)
Filtration	ISO Code 16/13, SAE Class 4 or better
Approx. Weight	.33 kg (.78 lbs.)
Cavity	C16-3S (See BC Section for more details)
Form Tool	Rougher NFT16-3SR Finisher NFT16-3SF

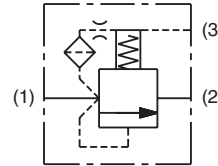
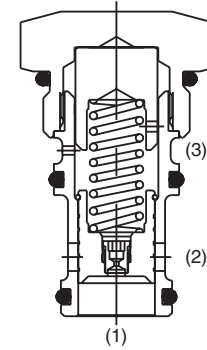

Dimensions Millimeters (Inches)

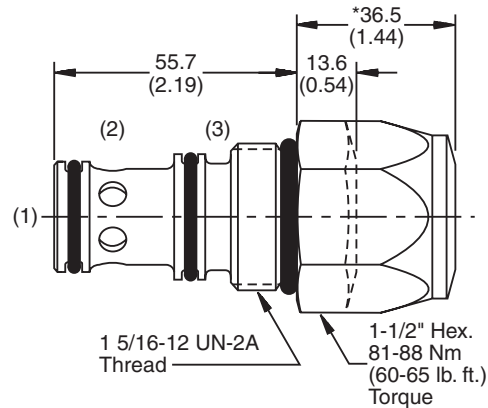

Ordering Information

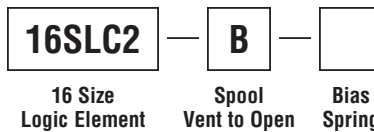

Code	Bias Spring
25	1.7 Bar (25 PSI)
50	3.5 Bar (50 PSI)
75	5.2 Bar (75 PSI)
*100	6.9 Bar (100 PSI)
*150	10.3 Bar (150 PSI)

*Indicates larger cap height, see drawing.

Seal Kit
WRK-16-3S

CV

Check Valves

SH

Shuttle Valves

LM

Load/Motor Controls

FC

Flow Controls

PC

Pressure Controls

LE

Logic Elements

DC

Directional Controls

MV

Manual Valves

SV

Solenoid Valves

PV

Proportional Valves

CE

Coils & Electronics

BC

Bodies & Cavities

TD

Technical Data

Technical Information

- CV** Check Valves
- SH** Shuttle Valves
- LM** Load/Motor Controls
- FC** Flow Controls
- PC** Pressure Controls
- LE** Logic Elements
- DC** Directional Controls
- MV** Manual Valves
- SV** Solenoid Valves
- PV** Proportional Valves
- CE** Coils & Electronics
- BC** Bodies & Cavities
- TD** Technical Data

General Description

Spool Type, Normally Closed, Vent to Open Logic Element. For additional information see Technical Tips on pages LE1-LE6.

Features

- Hardened, precision ground parts for durability
- Polyurethane seals only
- No backup rings
- All external parts zinc plated

Performance Curve

Pressure Drop vs. Flow (Through cartridge only)

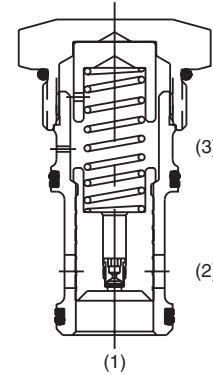
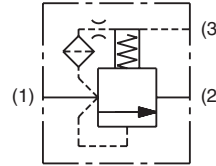
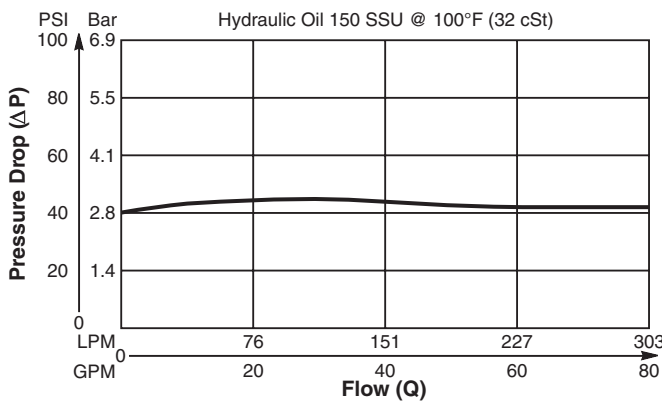

Dimensions Millimeters (Inches)

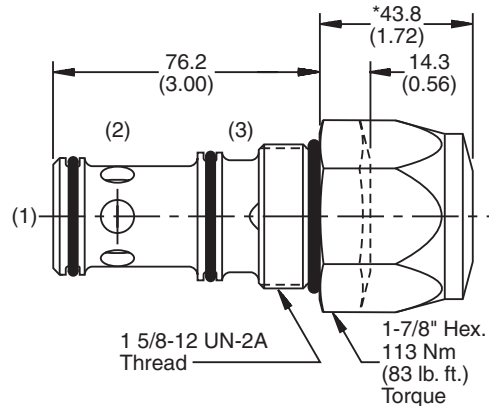

Specifications

Rated Flow	303 LPM (80 GPM)
Maximum Inlet Pressure	240 Bar (3500 PSI)
Leakage @ 150 SSU (32 cst)	Port 1 to 2 82 cc/min. (5 in ³ /min.) @ 240 Bar (3500 PSI)
Cartridge Material	All parts steel. All operating parts hardened steel.
Operating Temp. Range/Seals	-45°C to +93.3°C (Polyurethane) (-50°F to +200°F)
Fluid Compatibility/Viscosity	Mineral-based or synthetic with lubricating properties at viscosities of 45 to 2000 SSU (6 to 420 cSt)
Filtration	ISO Code 16/13, SAE Class 4 or better
Approx. Weight	.81 kg (1.78 lbs.)
Cavity	C20-3S (See BC Section for more details)
Form Tool	Rougher NFT20-3SR Finisher NFT20-3SF

Ordering Information

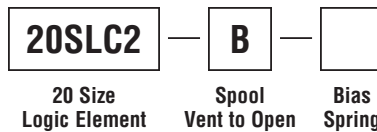

Code	Bias Spring
25	1.7 Bar (25 PSI)
50	3.5 Bar (50 PSI)
*75	5.2 Bar (75 PSI)
*100	6.9 Bar (100 PSI)
*150	10.3 Bar (150 PSI)

*Indicates larger cap height, see drawing.

Seal Kit
WRK-20-3S

General Description

Spool Type , Normally Closed, Vent to Open Logic Element. For additional information see Technical Tips on pages LE1-LE6.

Features

- High flow capacity
- Used as high flow switching or metering element
- Can be used as main stage for a pilot operated relief or sequence valve
- Integral 250 micron pilot flow filter
- Various switching pressures available
- 1:1 pilot pressure ratio
- Hardened working parts for maximum durability
- All external parts zinc plated

Performance Curve (Through cartridge only)

Vented Open Pressure Drop vs. Flow 1 to 2

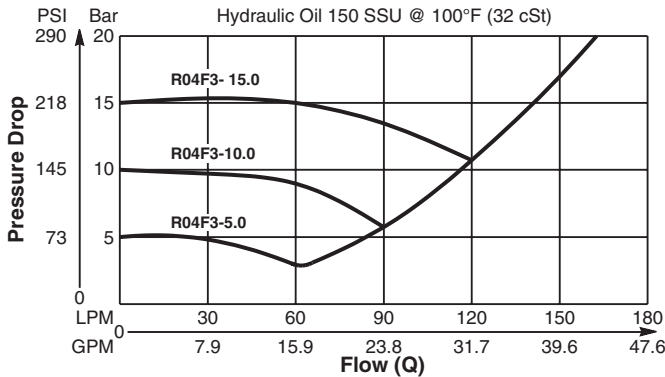

Specifications

Rated Flow	170 LPM (45 GPM)
Nominal Flow @ 7 Bar (100 PSI)	100 LPM (26 GPM)
Maximum Inlet Pressure	420 Bar (6000 PSI)
Leakage @ 150 SSU (32 cst)	50 ml/min. @ 100 Bar (1450 PSI)
Switching Press.	See ordering information
Cartridge Material	All parts steel. All operating parts hardened steel.
Operating Temp. Range/Seals	-40°C to +93.3°C (Nitrile) (-40°F to +200°F) -31.7°C to +121.1°C (Fluorocarbon) (-25°F to +250°F)
Fluid Compatibility/Viscosity	Mineral-based or synthetic with lubricating properties at viscosities of 45 to 2000 SSU (6 to 420 cSt)
Filtration	ISO Code 16/13, SAE Class 4 or better
Approx. Weight	.13 kg (.29 lbs.)
Cavity	C10-3S (See BC Section for more details)
Form Tool	Rougher NFT10-3SR Finisher NFT10-3SF

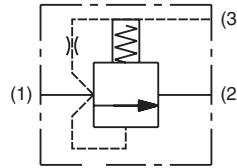
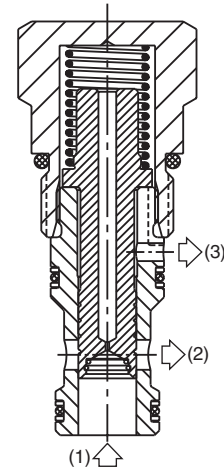

Dimensions Millimeters (Inches)

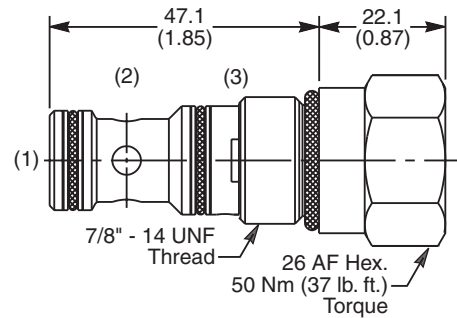

Ordering Information

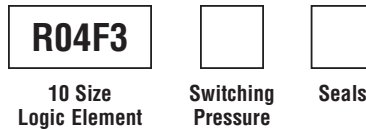

Code	Switching Pressure Non Adjustable Preset
1.0	1.0 Bar (14.5 PSI)
5.0	5.0 Bar (73 PSI) Std.
10.0	10.0 Bar (145 PSI)
15.0	15.0 Bar (218 PSI)
20.0	20.0 Bar (290 PSI)

Code	Seals / Kit. No.
N	Nitrile, Buna-N (Std.) / (SK30504N-1)
V	Fluorocarbon / (SK30504V-1)

If no switching pressure is specified, valve will be supplied as R04F3-5.0N

- CV** Check Valves
- SH** Shuttle Valves
- LM** Load/Motor Controls
- FC** Flow Controls
- PC** Pressure Controls
- LE** Logic Elements
- DC** Directional Controls
- MV** Manual Valves
- SV** Solenoid Valves
- PV** Proportional Valves
- CE** Coils & Electronics
- BC** Bodies & Cavities
- TD** Technical Data

Technical Information

- CV** Check Valves
- SH** Shuttle Valves
- LM** Load/Motor Controls
- FC** Flow Controls
- PC** Pressure Controls
- LE** Logic Elements
- DC** Directional Controls
- MV** Manual Valves
- SV** Solenoid Valves
- PV** Proportional Valves
- CE** Coils & Electronics
- BC** Bodies & Cavities
- TD** Technical Data

General Description

Spool Type , Normally Closed, Vent to Open Logic Element. For additional information see Technical Tips on pages LE1-LE6.

Features

- High flow capacity
- Used as high flow switching or metering element
- Can be used as main stage for a pilot operated relief or sequence valve
- Integral 250 micron pilot flow filter
- Various switching pressures available
- 1:1 pilot pressure ratio
- Hardened working parts for maximum durability
- All external parts zinc plated

Performance Curve (Through cartridge only)
Vented Open Pressure Drop vs. Flow 1 to 2

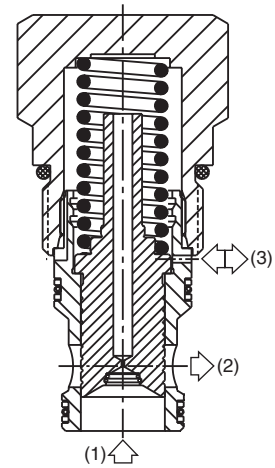
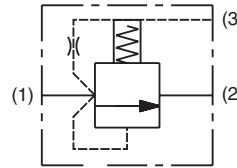
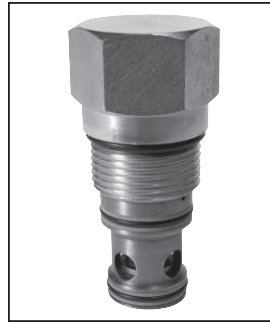
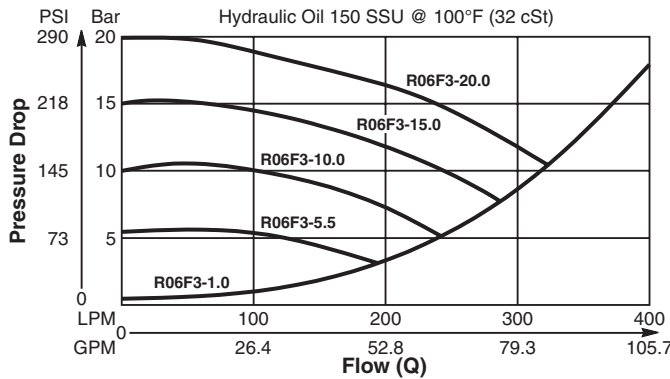

Dimensions Millimeters (Inches)

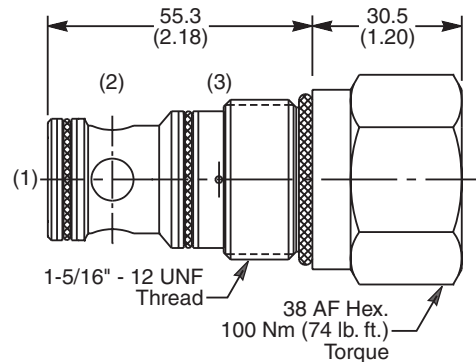

Specifications

Rated Flow	400 LPM (106 GPM)
Nominal Flow @ 7 Bar (100 PSI)	270 LPM (71 GPM)
Maximum Inlet Pressure	420 Bar (6000 PSI)
Leakage @ 150 SSU (32 cst)	90 ml/min. @ 100 Bar (1450 PSI)
Switching Press.	See ordering information
Cartridge Material	All parts steel. All operating parts hardened steel.
Operating Temp. Range/Seals	-40°C to +93.3°C (Nitrile) (-40°F to +200°F) -31.7°C to +121.1°C (Fluorocarbon) (-25°F to +250°F)
Fluid Compatibility/Viscosity	Mineral-based or synthetic with lubricating properties at viscosities of 45 to 2000 SSU (6 to 420 cSt)
Filtration	ISO Code 16/13, SAE Class 4 or better
Approx. Weight	.38 kg (.84 lbs.)
Cavity	C16-3S (See BC Section for more details)
Form Tool	Rougher NFT16-3SR Finisher NFT16-3SF

Ordering Information

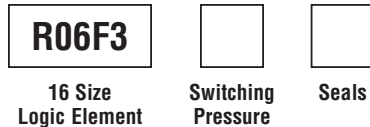

Code	Switching Pressure Non Adjustable Preset
1.0	1.0 Bar (14.5 PSI)
5.5	5.5 Bar (80 PSI) Std.
10.0	10.0 Bar (145 PSI)
15.0	15.0 Bar (218 PSI)
20.0	20.0 Bar (290 PSI)

Code	Seals / Kit. No.
N	Nitrile, Buna-N (Std.) / (SK30508N-1)
V	Fluorocarbon / (SK30508V-1)

If no switching pressure is specified, valve will be supplied as R06F3-5.5N

General Description

Spool Type , Normally Closed, Vent to Open Logic Element. For additional information see Technical Tips on pages LE1-LE6.

Features

- High flow capacity
- Can be used as high flow switching or metering element
- Can be used as main stage for a pilot operated relief or sequence valve
- Integral 250 micron pilot flow filter
- Various switching pressures available
- 1:1 pilot pressure ratio
- Hardened working parts for maximum durability
- All external parts zinc plated

Performance Curve (Through cartridge only)
Vented Open Pressure Drop vs. Flow 1 to 2

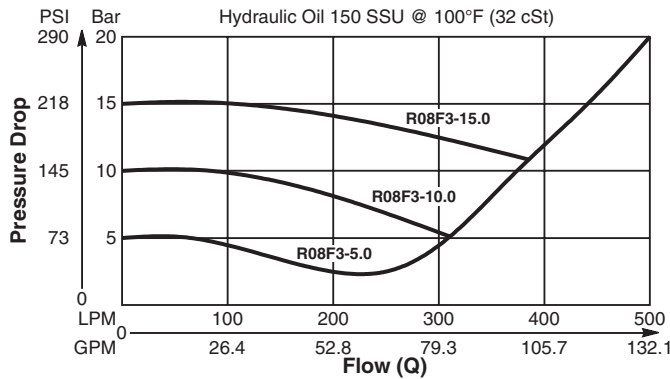

Specifications

Rated Flow	500 LPM (132 GPM)
Nominal Flow @ 7 Bar (100 PSI)	340 LPM (90 GPM)
Maximum Inlet Pressure	420 Bar (6000 PSI)
Leakage @ 150 SSU (32 cst)	90 ml/min. @ 100 Bar (1450 PSI)
Switching Press.	See ordering information
Cartridge Material	All parts steel. All operating parts hardened steel.
Operating Temp. Range/Seals	-40°C to +93.3°C (Nitrile) (-40°F to +200°F) -31.7°C to +121.1°C (Fluorocarbon) (-25°F to +250°F)
Fluid Compatibility/Viscosity	Mineral-based or synthetic with lubricating properties at viscosities of 45 to 2000 SSU (6 to 420 cSt)
Filtration	ISO Code 16/13, SAE Class 4 or better
Approx. Weight	.69 kg (1.52 lbs.)
Cavity	C20-3S (See BC Section for more details)
Form Tool	Rougher NFT20-3SR Finisher NFT20-3SF

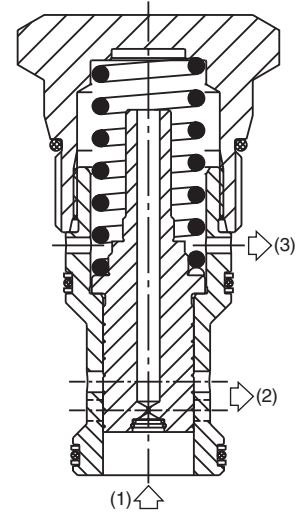
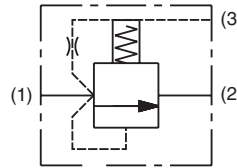
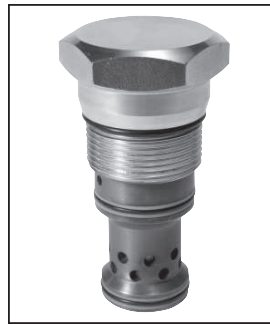

Dimensions Millimeters (Inches)

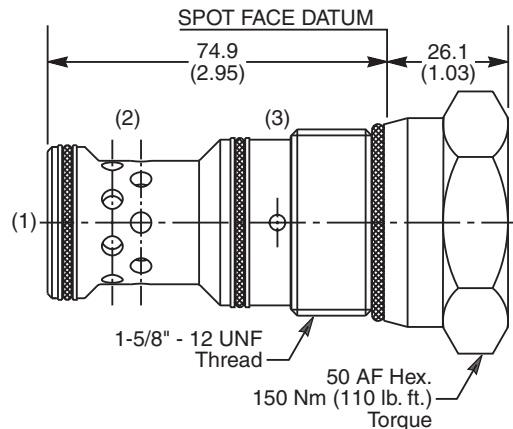

Ordering Information

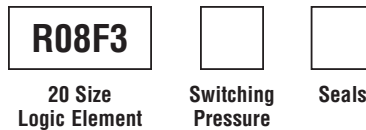

Code	Switching Pressure Non Adjustable Preset
5.5	5.5 Bar (80 PSI) Std.
10.0	10.0 Bar (145 PSI)
15.0	15.0 Bar (218 PSI)
20.0	20.0 Bar (290 PSI)

Code	Seals / Kit. No.
N	Nitrile, Buna-N (Std.) / (SK30512N-1)
V	Fluorocarbon / (SK30512V-1)

If no switching pressure is specified, valve will be supplied as R08E3-5.5N

- CV** Check Valves
- SH** Shuttle Valves
- LM** Load/Motor Controls
- FC** Flow Controls
- PC** Pressure Controls
- LE** Logic Elements
- DC** Directional Controls
- MV** Manual Valves
- SV** Solenoid Valves
- PV** Proportional Valves
- CE** Coils & Electronics
- BC** Bodies & Cavities
- TD** Technical Data

Technical Information

- CV** Check Valves
- SH** Shuttle Valves
- LM** Load/Motor Controls
- FC** Flow Controls
- PC** Pressure Controls
- LE** Logic Elements
- DC** Directional Controls
- MV** Manual Valves
- SV** Solenoid Valves
- PV** Proportional Valves
- CE** Coils & Electronics
- BC** Bodies & Cavities
- TD** Technical Data

General Description

Spool Type, Normally Open, Logic Element. This type is ideal for flow control functions. For additional information see Technical Tips on pages LE1-LE6.

Features

- Hardened, precision ground parts for durability
- Polyurethane seals only
- No backup rings
- All external parts zinc plated

Performance Curve

Pressure Drop vs. Flow (Through cartridge only)

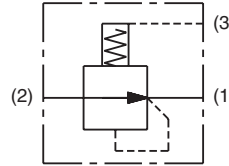
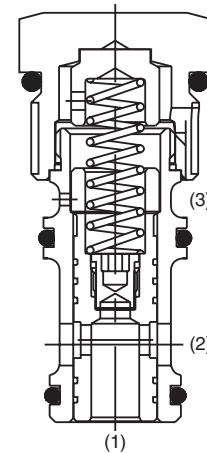
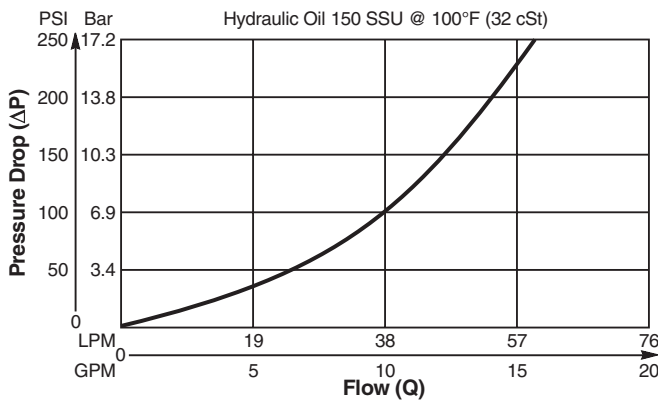

Dimensions Millimeters (Inches)

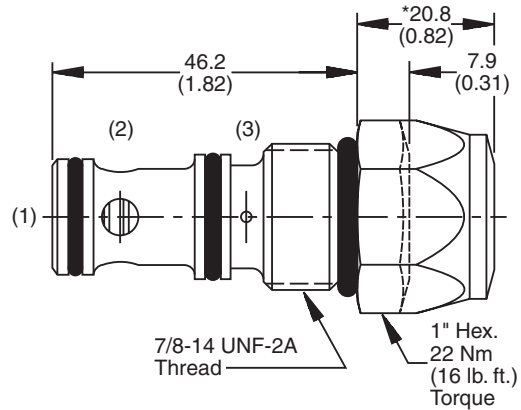

Specifications

Rated Flow	57 LPM (15 GPM)
Maximum Inlet Pressure	240 Bar (3500 PSI)
Leakage @ 150 SSU (32 cst)	Port 1 to 2 82 cc/min. (5 in ³ /min.) @ 240 Bar (3500 PSI)
Cartridge Material	All parts steel. All operating parts hardened steel.
Operating Temp. Range/Seals	-45°C to +93.3°C (Polyurethane) (-50°F to +200°F)
Fluid Compatibility/Viscosity	Mineral-based or synthetic with lubricating properties at viscosities of 45 to 2000 SSU (6 to 420 cSt)
Filtration	ISO Code 16/13, SAE Class 4 or better
Approx. Weight	.14 kg (.30 lbs.)
Cavity	C10-3S (See BC Section for more details)
Form Tool	Rougher NFT10-3SR Finisher NFT10-3SF

Ordering Information

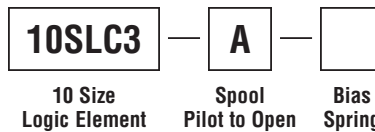

Code	Bias Spring
25	1.7 Bar (25 PSI)
50	3.5 Bar (50 PSI)
75	5.2 Bar (75 PSI)
*100	6.9 Bar (100 PSI)
*150	10.3 Bar (150 PSI)

*Indicates larger cap height, see drawing.

Seal Kit
WRK-10-3S

General Description

Spool Type , Normally Open, Logic Element. This type is ideal for flow control functions. For additional information see Technical Tips on pages LE1-LE6.

Features

- Hardened, precision ground parts for durability
- Polyurethane seals only
- No backup rings
- All external parts zinc plated

Performance Curve

Pressure Drop vs. Flow (Through cartridge only)

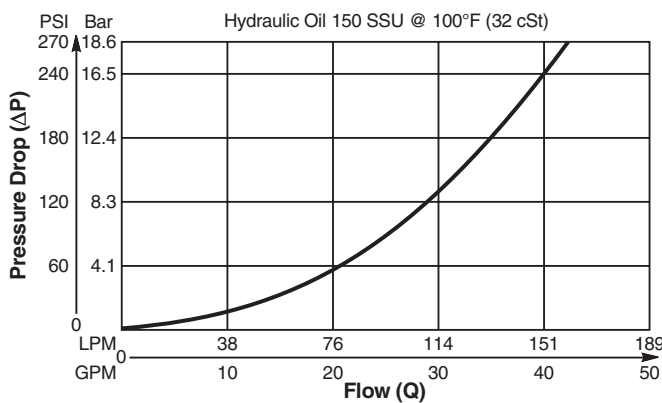

Specifications

Rated Flow	189 LPM (50 GPM)
Maximum Inlet Pressure	240 Bar (3500 PSI)
Leakage @ 150 SSU (32 cst)	Port 1 to 2 82 cc/min. (5 in ³ /min.) @ 240 Bar (3500 PSI)
Cartridge Material	All parts steel. All operating parts hardened steel.
Operating Temp. Range/Seals	-45°C to +93.3°C (Polyurethane) (-50°F to +200°F)
Fluid Compatibility/ Viscosity	Mineral-based or synthetic with lubricating properties at viscosities of 45 to 2000 SSU (6 to 420 cSt)
Filtration	ISO Code 16/13, SAE Class 4 or better
Approx. Weight	.33 kg (.78 lbs.)
Cavity	C16-3S (See BC Section for more details)
Form Tool	Rougher NFT16-3SR Finisher NFT16-3SF

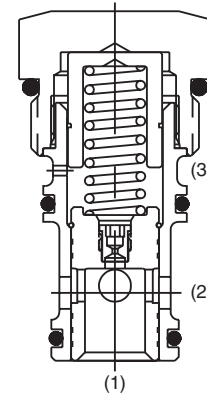
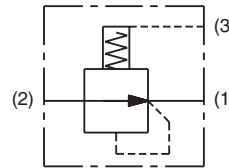

Dimensions Millimeters (Inches)

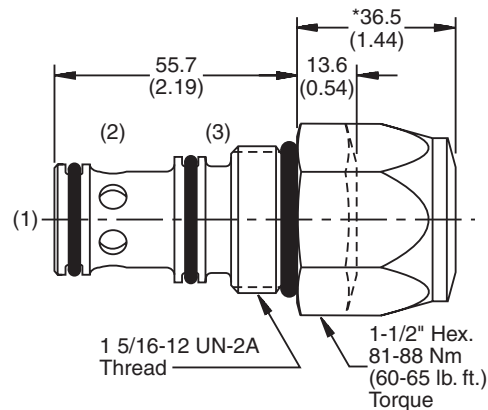

Ordering Information

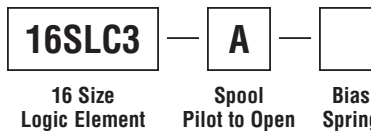

Code	Bias Spring
25	1.7 Bar (25 PSI)
50	3.5 Bar (50 PSI)
75	5.2 Bar (75 PSI)
*100	6.9 Bar (100 PSI)
*150	10.3 Bar (150 PSI)

*Indicates larger cap height, see drawing.

Seal Kit
WRK-16-3S

- CV**
- Check Valves
- SH**
- Shuttle Valves
- LM**
- Load/Motor Controls
- FC**
- Flow Controls
- PC**
- Pressure Controls
- LE**
- Logic Elements
- DC**
- Directional Controls
- MV**
- Manual Valves
- SV**
- Solenoid Valves
- PV**
- Proportional Valves
- CE**
- Coils & Electronics
- BC**
- Bodies & Cavities
- TD**
- Technical Data

Technical Information

- CV** Check Valves
- SH** Shuttle Valves
- LM** Load/Motor Controls
- FC** Flow Controls
- PC** Pressure Controls
- LE** Logic Elements
- DC** Directional Controls
- MV** Manual Valves
- SV** Solenoid Valves
- PV** Proportional Valves
- CE** Coils & Electronics
- BC** Bodies & Cavities
- TD** Technical Data

General Description

Spool Type , Normally Open, Vent to Close Logic Element. For additional information see Technical Tips on pages LE1-LE6.

Features

- High flow capacity
- Used as high flow switching or metering element
- Can be used for inline pressure compensated flow control when used with restrictor (refer to application)
- More stable than poppet type
- Various switching pressures available
- 1:1 pilot ratio
- Hardened working parts for maximum durability
- All external parts zinc plated

Performance Curve

Pressure Drop vs. Flow (Through cartridge only)

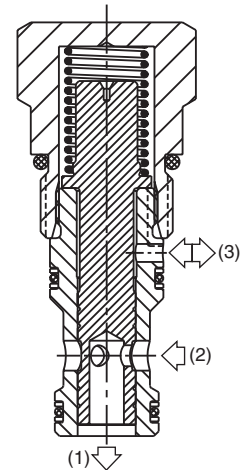
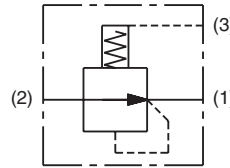
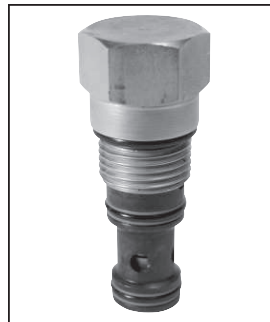
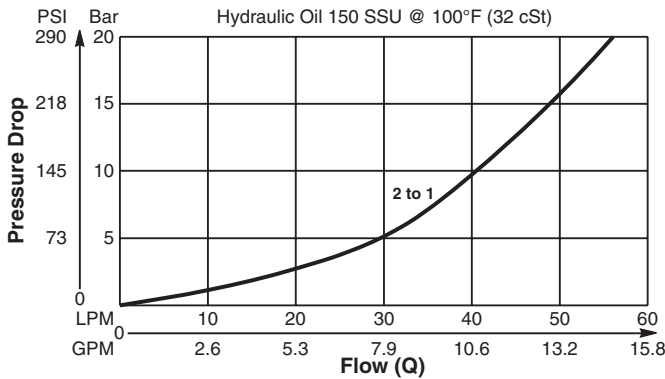

Dimensions Millimeters (Inches)

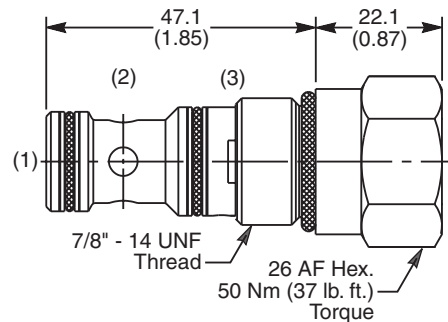

Specifications

Rated Flow	58 LPM (15 GPM)
Nominal Flow @ 7 Bar (100 PSI)	35 LPM (9.2 GPM)
Maximum Inlet Pressure	420 Bar (6000 PSI)
Leakage @ 150 SSU (32 cst)	50 ml/min. @ 100 Bar (1450 PSI)
Switching Press.	See ordering information
Cartridge Material	All parts steel. All operating parts hardened steel.
Operating Temp. Range/Seals	-40°C to +93.3°C (Nitrile) (-40°F to +200°F) -31.7°C to +121.1°C (Fluorocarbon) (-25°F to +250°F)
Fluid Compatibility/Viscosity	Mineral-based or synthetic with lubricating properties at viscosities of 45 to 2000 SSU (6 to 420 cSt)
Filtration	ISO Code 16/13, SAE Class 4 or better
Approx. Weight	.14 kg (.31 lbs.)
Cavity	C10-3S (See BC Section for more details)
Form Tool	Rougher NFT10-3SR Finisher NFT10-3SF

Ordering Information

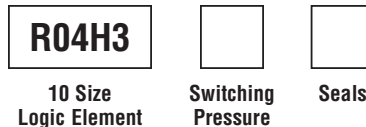

Code	Switching Pressure Non Adjustable Preset
1.0	1.0 Bar (14.5 PSI)
5.0	5.0 Bar (73 PSI) Std.
10.0	10.0 Bar (145 PSI)
15.0	15.0 Bar (218 PSI)
20.0	20.0 Bar (290 PSI)

Code	Seals / Kit. No.
N	Nitrile, Buna-N (Std.) / (SK30504N-1)
V	Fluorocarbon / (SK30504V-1)

If no switching pressure is specified, valve will be supplied as R04H3-5.0N

General Description

Spool Type , Normally Open, Vent to Close Logic Element. For additional information see Technical Tips on pages LE1-LE6.

Features

- High flow capacity
- Used as high flow switching or metering element
- Can be used for inline pressure compensated flow control when used with restrictor (refer to application)
- More stable than poppet type
- Range of spring ratings available
- Integral 250 micron pilot flow filter
- 1:1 pilot ratio
- Hardened working parts for maximum durability
- All external parts zinc plated

Performance Curve

Pressure Drop vs. Flow (Through cartridge only)

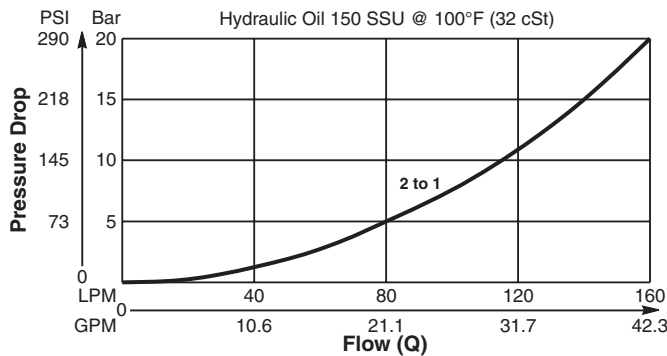

Specifications

Rated Flow	160 LPM (42 GPM)
Nominal Flow @ 7 Bar (100 PSI)	90 LPM (24 GPM)
Maximum Inlet Pressure	420 Bar (6000 PSI)
Leakage @ 150 SSU (32 cst)	125 ml/min. @ 100 Bar (1450 PSI)
Switching Press.	See ordering information
Cartridge Material	All parts steel. All operating parts hardened steel.
Operating Temp. Range/Seals	-40°C to +93.3°C (Nitrile) (-40°F to +200°F) -31.7°C to +121.1°C (Fluorocarbon) (-25°F to +250°F)
Fluid Compatibility/Viscosity	Mineral-based or synthetic with lubricating properties at viscosities of 45 to 2000 SSU (6 to 420 cSt)
Filtration	ISO Code 16/13, SAE Class 4 or better
Approx. Weight	.37 kg (.82 lbs.)
Cavity	C16-3S (See BC Section for more details)
Form Tool	Rougher NFT16-3SR Finisher NFT16-3SF

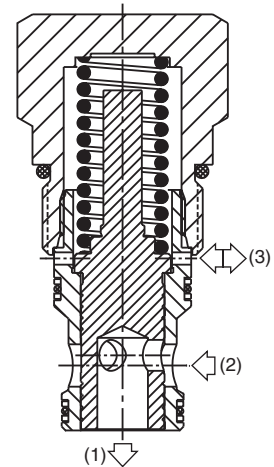
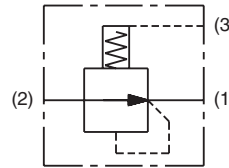
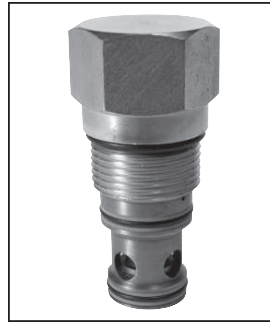

Dimensions Millimeters (Inches)

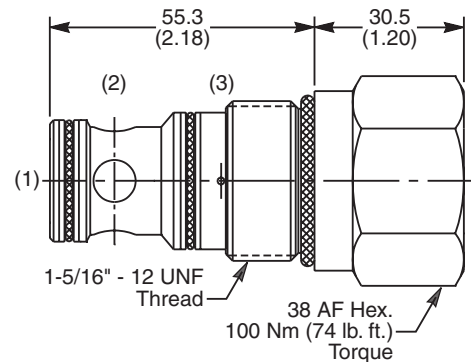

Ordering Information

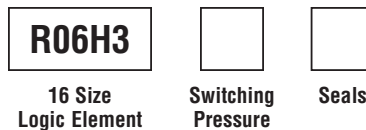

Code	Switching Pressure Non Adjustable Preset
1.0	1.0 Bar (14.5 PSI)
5.5	5.5 Bar (80 PSI) Std.
10.0	10.0 Bar (145 PSI)
15.0	15.0 Bar (218 PSI)
20.0	20.0 Bar (290 PSI)

Code	Seals / Kit. No.
N	Nitrile, Buna-N (Std.) / (SK30508N-1)
V	Fluorocarbon / (SK30508V-1)

If no switching pressure is specified, valve will be supplied as R06H3-5.5N

- CV**
- Check Valves
- SH**
- Shuttle Valves
- LM**
- Load/Motor Controls
- FC**
- Flow Controls
- PC**
- Pressure Controls
- LE**
- Logic Elements
- DC**
- Directional Controls
- MV**
- Manual Valves
- SV**
- Solenoid Valves
- PV**
- Proportional Valves
- CE**
- Coils & Electronics
- BC**
- Bodies & Cavities
- TD**
- Technical Data

Technical Information

- CV** Check Valves
- SH** Shuttle Valves
- LM** Load/Motor Controls
- FC** Flow Controls
- PC** Pressure Controls
- LE** Logic Elements
- DC** Directional Controls
- MV** Manual Valves
- SV** Solenoid Valves
- PV** Proportional Valves
- CE** Coils & Electronics
- BC** Bodies & Cavities
- TD** Technical Data

General Description

Spool Type, Normally Open, Vent to Close Logic Element. This type is ideal for pressure reducing functions. For additional information see Technical Tips on pages LE1-LE6.

Features

- Hardened, precision ground parts for durability
- Polyurethane seals only
- No backup rings
- All external parts zinc plated

Performance Curve

Pressure Drop vs. Flow (Through cartridge only)

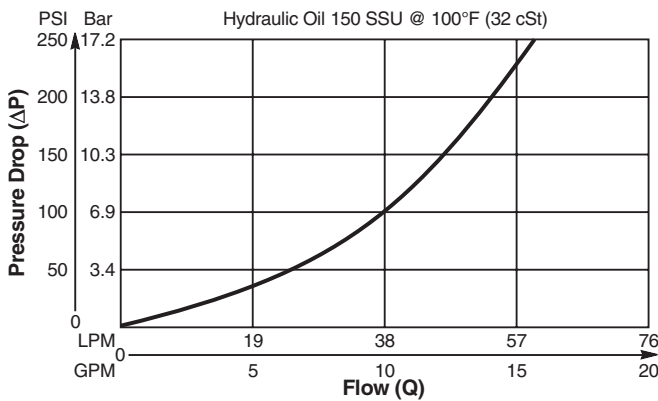

Specifications

Rated Flow	57 LPM (15 GPM)
Maximum Inlet Pressure	240 Bar (3500 PSI)
Leakage @ 150 SSU (32 cst)	Port 1 to 2 82 cc/min. (5 in ³ /min.) @ 240 Bar (3500 PSI)
Cartridge Material	All parts steel. All operating parts hardened steel.
Operating Temp. Range/Seals	-45°C to +93.3°C (Polyurethane) (-50°F to +200°F)
Fluid Compatibility/Viscosity	Mineral-based or synthetic with lubricating properties at viscosities of 45 to 2000 SSU (6 to 420 cSt)
Filtration	ISO Code 16/13, SAE Class 4 or better
Approx. Weight	.14 kg (.30 lbs.)
Cavity	C10-3S (See BC Section for more details)
Form Tool	Rougher NFT10-3SR Finisher NFT10-3SF

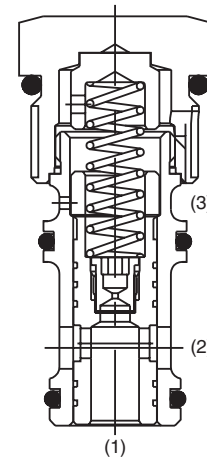
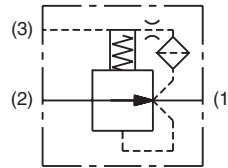
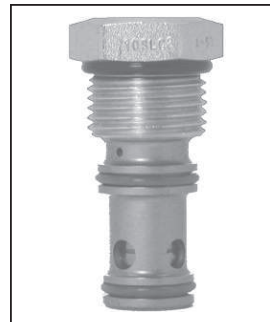

Dimensions Millimeters (Inches)

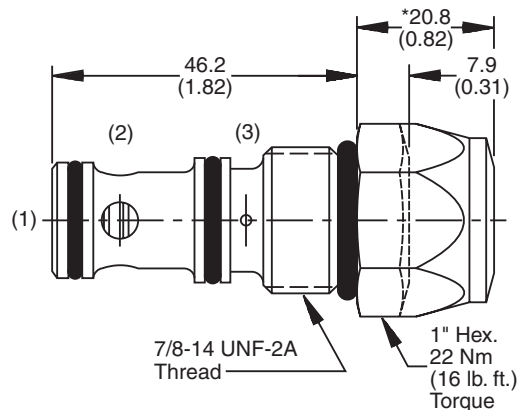

Ordering Information

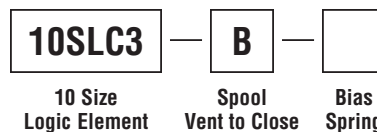

Code	Bias Spring
25	1.7 Bar (25 PSI)
50	3.5 Bar (50 PSI)
75	5.2 Bar (75 PSI)
*100	6.9 Bar (100 PSI)
*150	10.3 Bar (150 PSI)

*Indicates larger cap height, see drawing.

Seal Kit
WRK-10-3S

General Description

Spool Type , Normally Open, Vent to Close Logic Element. This type is ideal for pressure reducing functions. For additional information see Technical Tips on pages LE1-LE6.

Features

- Hardened, precision ground parts for durability
- Polyurethane seals only
- No backup rings
- All external parts zinc plated

Performance Curve

Pressure Drop vs. Flow (Through cartridge only)

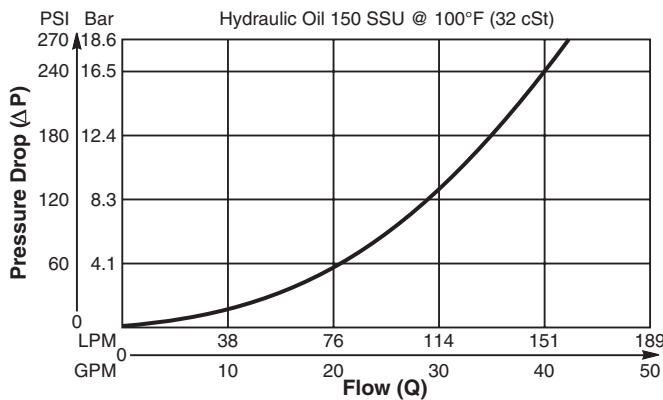

Specifications

Rated Flow	189 LPM (50 GPM)
Maximum Inlet Pressure	240 Bar (3500 PSI)
Leakage @ 150 SSU (32 cst)	Port 1 to 2 82 cc/min. (5 in ³ /min) @ 240 Bar (3500 PSI)
Cartridge Material	All parts steel. All operating parts hardened steel.
Operating Temp. Range/Seals	-45°C to +93.3°C (Polyurethane) (-50°F to +200°F)
Fluid Compatibility/Viscosity	Mineral-based or synthetic with lubricating properties at viscosities of 45 to 2000 SSU (6 to 420 cSt)
Filtration	ISO Code 16/13, SAE Class 4 or better
Approx. Weight	.33 kg (.78 lbs.)
Cavity	C16-3S (See BC Section for more details)
Form Tool	Rougher NFT16-3SR Finisher NFT16-3SF

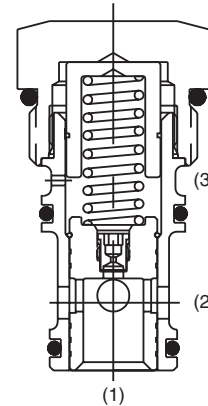
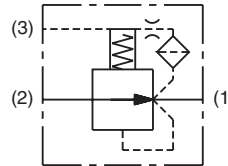

Dimensions Millimeters (Inches)

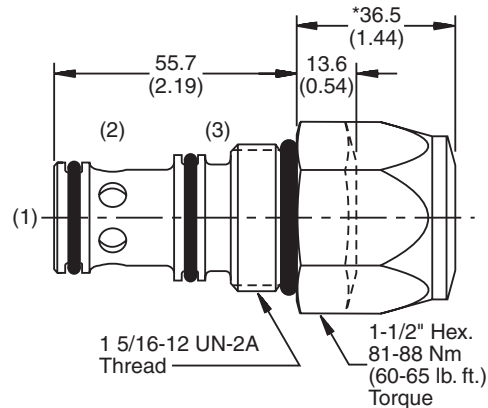

Ordering Information

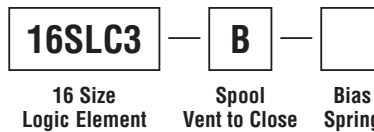

Code	Bias Spring
25	1.7 Bar (25 PSI)
50	3.5 Bar (50 PSI)
75	5.2 Bar (75 PSI)
*100	6.9 Bar (100 PSI)
*150	10.3 Bar (150 PSI)

*Indicates larger cap height, see drawing.

Seal Kit
WRK-16-3S

CV

Check Valves

SH

Shuttle Valves

LM

Load/Motor Controls

FC

Flow Controls

PC

Pressure Controls

LE

Logic Elements

DC

Directional Controls

MV

Manual Valves

SV

Solenoid Valves

PV

Proportional Valves

CE

Coils & Electronics

BC

Bodies & Cavities

TD

Technical Data

Technical Information

- CV** Check Valves
- SH** Shuttle Valves
- LM** Load/Motor Controls
- FC** Flow Controls
- PC** Pressure Controls
- LE** Logic Elements
- DC** Directional Controls
- MV** Manual Valves
- SV** Solenoid Valves
- PV** Proportional Valves
- CE** Coils & Electronics
- BC** Bodies & Cavities
- TD** Technical Data

General Description

Spool Type , Normally Open, Vent to Close Logic Element. For additional information see Technical Tips on pages LE1-LE6.

Features

- High flow capacity
- Used as high flow switching or metering element
- Can be used as pressure regulator with mainstage controlled remotely by a pilot relief valve or a proportional valve
- Various switching pressures available
- 1:1 pilot ratio
- Hardened working parts for maximum durability
- All external parts zinc plated

Performance Curve

Pressure Drop vs. Flow (Through cartridge only)

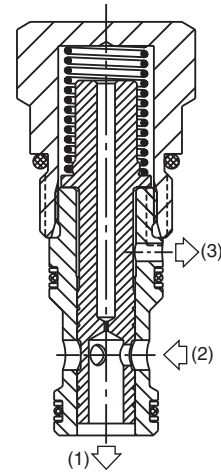
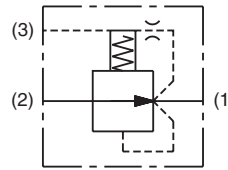
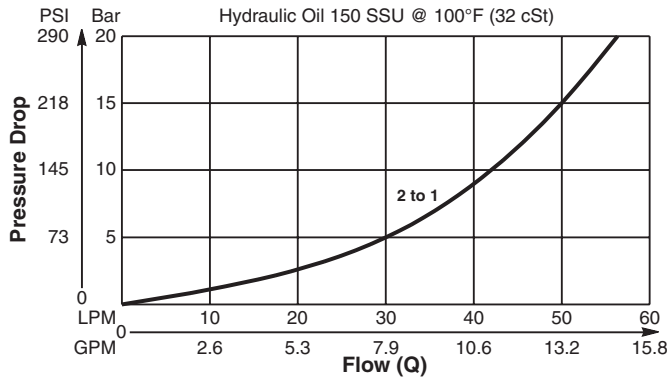

Dimensions Millimeters (Inches)

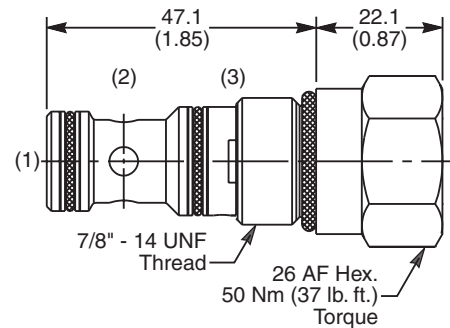

Specifications

Rated Flow	58 LPM (15 GPM)
Nominal Flow @ 7 Bar (100 PSI)	35 LPM (9.2 GPM)
Maximum Inlet Pressure	420 Bar (6000 PSI)
Leakage @ 150 SSU (32 cst)	50 ml/min. @ 100 Bar (1450 PSI)
Switching Press.	See ordering information
Cartridge Material	All parts steel. All operating parts hardened steel.
Operating Temp. Range/Seals	-40°C to +93.3°C (Nitrile) (-40°F to +200°F) -31.7°C to +121.1°C (Fluorocarbon) (-25°F to +250°F)
Fluid Compatibility/Viscosity	Mineral-based or synthetic with lubricating properties at viscosities of 45 to 2000 SSU (6 to 420 cSt)
Filtration	ISO Code 16/13, SAE Class 4 or better
Approx. Weight	.14 kg (.31 lbs.)
Cavity	C10-3S (See BC Section for more details)
Form Tool	Rougher NFT10-3SR Finisher NFT10-3SF

Ordering Information

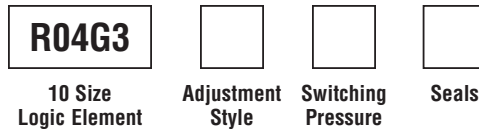

Code	Switching Pressure Non Adjustable Preset
1.0	1.0 Bar (14.5 PSI)
5.0	5.0 Bar (73 PSI) Std.
10.0	10.0 Bar (145 PSI)
15.0	15.0 Bar (218 PSI)
20.0	20.0 Bar (290 PSI)

Code	Seals / Kit. No.
N	Nitrile, Buna-N (Std.) / (SK30504N-1)
V	Fluorocarbon / (SK30504V-1)

If no switching pressure is specified, valve will be supplied as R04G3-5.0N



Technical Information

General Description

Spool Type , Normally Open, Vent to Close Logic Element. For additional information see Technical Tips on pages LE1-LE6.

Features

- High flow capacity
- Used as high flow switching or metering element
- Can be used as pressure regulator with mainstage controlled remotely by a pilot relief valve or a proportional valve
- Various switching pressures available
- Integral 250 micron pilot flow filter
- Hardened working parts for maximum durability
- All external parts zinc plated

Performance Curve

Pressure Drop vs. Flow (Through cartridge only)

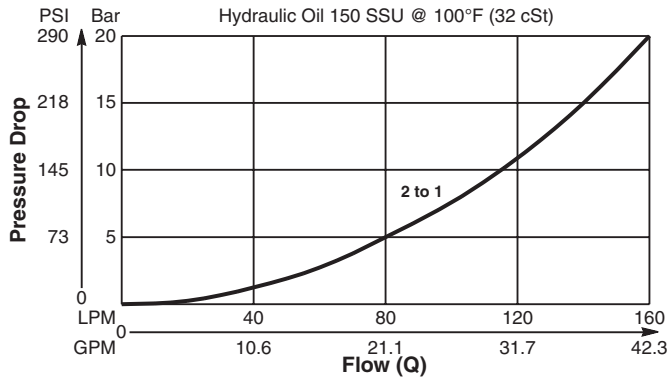

Specifications

Rated Flow	160 LPM (42 GPM)
Nominal Flow @ 7 Bar (100 PSI)	90 LPM (24 GPM)
Maximum Inlet Pressure	420 Bar (6000 PSI)
Leakage @ 150 SSU (32 cst)	125 ml/min. @ 100 Bar (1450 PSI)
Switching Press.	See ordering information
Cartridge Material	All parts steel. All operating parts hardened steel.
Operating Temp. Range/Seals	-40°C to +93.3°C (Nitrile) (-40°F to +200°F) -31.7°C to +121.1°C (Fluorocarbon) (-25°F to +250°F)
Fluid Compatibility/Viscosity	Mineral-based or synthetic with lubricating properties at viscosities of 45 to 2000 SSU (6 to 420 cSt)
Filtration	ISO Code 16/13, SAE Class 4 or better
Approx. Weight	.38 kg (.84 lbs.)
Cavity	C16-3S (See BC Section for more details)
Form Tool	Rougher NFT16-3SR Finisher NFT16-3SF

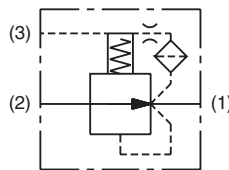
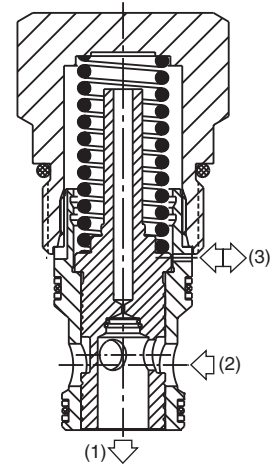
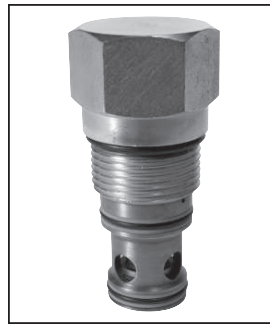

Dimensions Millimeters (Inches)

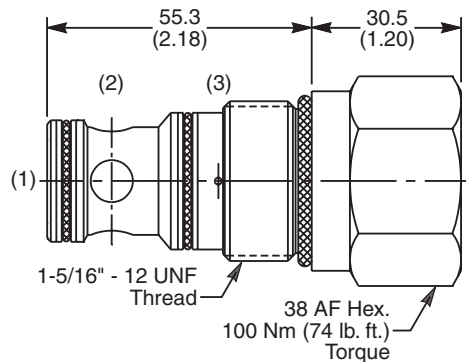

Ordering Information

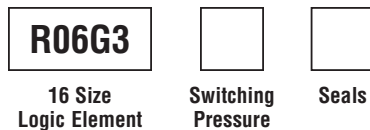

Code	Switching Pressure Non Adjustable Preset
1.0	1.0 Bar (14.5 PSI)
5.5	5.5 Bar (80 PSI) Std.
10.0	10.0 Bar (145 PSI)
15.0	15.0 Bar (218 PSI)
20.0	20.0 Bar (290 PSI)







Code	Seals / Kit. No.
N	Nitrile, Buna-N (Std.) / (SK30508N-1)
V	Fluorocarbon / (SK30508V-1)

If no switching pressure is specified, valve will be supplied as R06G3-5.5N

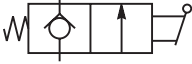
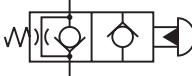
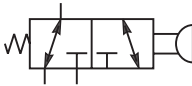
- CV Check Valves
- SH Shuttle Valves
- LM Load/Motor Controls
- FC Flow Controls
- PC Pressure Controls
- LE Logic Elements
- DC Directional Controls
- MV Manual Valves
- SV Solenoid Valves
- PV Proportional Valves
- CE Coils & Electronics
- BC Bodies & Cavities
- TD Technical Data

Contents

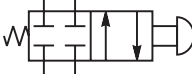
Manual Valves

	SERIES	CAVITY	DESCRIPTION	FLOW LPM/GPM	PRESSURE BAR/PSI	PAGE NO.
	DL081	C08-2	2 Position, 2 Way, N.C. Poppet, Pull to Open	30/8	210/3000	MV1
	DL101	C10-2	2 Position, 2 Way, N.C. Poppet, Pull to Open	49/13	210/3000	MV2
	GM0212	C08-2	2 Position, 2 Way, N.O. Poppet, Push to Close	45/12	350/5000	MV3
	GM0233	C08-3	2 Position, 3 Way, Spool Type, Pull to Shift	19/5	350/5000	MV4
	DM103	C10-3	3 Way, Rotary Spool	22/6	240/3500	MV5-MV6
	DM104	C10-4	4 Way, Rotary Spool	7/2	240/3500	MV7-MV8
						
	GM0240XS	C08-4	2 Position, 4 Way, Push to Shift	15/4	350/5000	MV9
	GM0240CS	C08-4	2 Position, 4 Way, Push to Shift	15/4	350/5000	MV10
						
	DMH085C1	C08-4	3 Position, 4 Way, Closed Center, Pull to Shift and Push to Shift	17/5	350/5000	MV11-MV12
	DMH085C4	C08-4	3 Position, 4 Way, Float Center, Pull to Shift and Push to Shift	17/5	350/5000	MV11-MV12
	DMH085C9	C08-4	3 Position, 4 Way, Tandem Center, Pull to Shift and Push to Shift	15/4	350/5000	MV11-MV12
	DMH085C2	C08-4	3 Position, 4 Way, Open Center, Pull to Shift and Push to Shift	15/4	350/5000	MV11-MV12

*DMH085** Series will be available January 1, 2011.*

- CV**
Check Valves
- SH**
Shuttle Valves
- LM**
Load/Motor Controls
- FC**
Flow Controls
- PC**
Pressure Controls
- LE**
Logic Elements
- DC**
Directional Controls
- MV**
Manual Valves
- SV**
Solenoid Valves
- PV**
Proportional Valves
- CE**
Coils & Electronics
- BC**
Bodies & Cavities
- TD**
Technical Data

Technical Information

- CV** Check Valves
- SH** Shuttle Valves
- LM** Load/Motor Controls
- FC** Flow Controls
- PC** Pressure Controls
- LE** Logic Elements
- DC** Directional Controls
- MV** Manual Valves
- SV** Solenoid Valves
- PV** Proportional Valves
- CE** Coils & Electronics
- BC** Bodies & Cavities
- TD** Technical Data

General Description

2-Way Manual Poppet Valve. The DL081 Series Valves are suited for emergency lowering applications and on-off flow applications.

Operation

The DL081 Series Valves are mechanically operated check valves. Hydraulic force on the poppet is balanced by having equal area between the poppet seat and the valve stem, allowing the poppet to be manually pulled off the seat. When released, the bias spring will return the valve poppet to its closed position. Back pressure of more than 5.5 Bar (80 PSI) will prevent the bias spring from closing the poppet and must be avoided.

Features

- Low leakage design
- Flip lever, pull handle, or detented pin design
- All external parts zinc plated

Performance Curve

Flow vs. Pressure Drop (Through cartridge only)

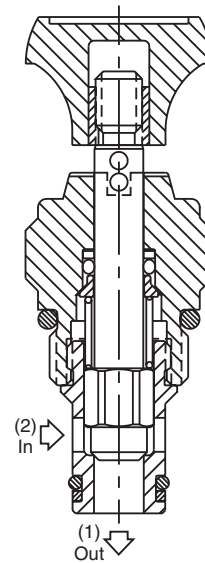
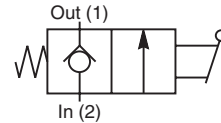
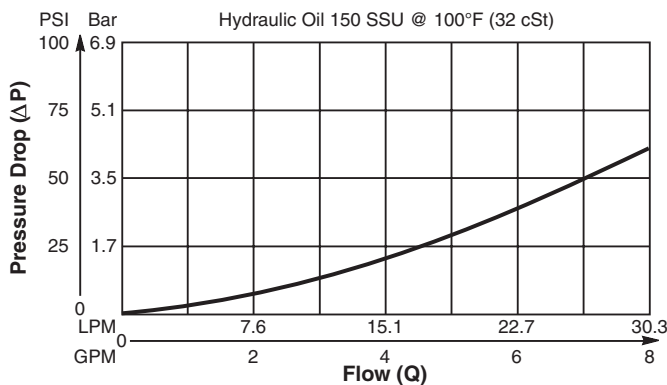

Dimensions Millimeters (Inches)

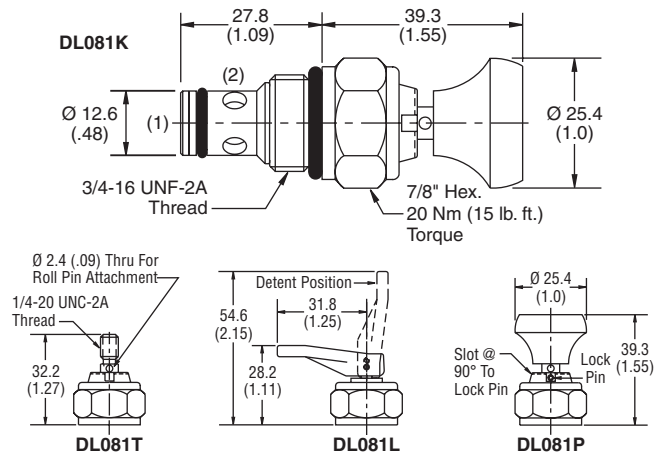

Specifications

Nominal Flow	30 LPM (8 GPM)
Max. Inlet Pressure	210 Bar (3000 PSI)
Leakage at 150 SSU (32 cSt)	5 drops/min. (.33 cc/min.) at 210 Bar (3000 PSI)
Max. Allowable Tankline Pressure	5.5 Bar (80 PSI)
Operating Temp. Range (Ambient)	-40°C to +93.3°C (Nitrile) (-40°F to +200°F) -31.7°C to +121.1°C (Fluorocarbon) (-25°F to +250°F)
Cartridge Material	Stem, stainless steel. All other parts hardened steel.
Filtration	ISO code 16/13, SAE Class 4 or better
Approx. Weight	0.08 kg (0.17 lbs.)
Cavity	C08-2
Form Tool	Rougher None Finisher NFT08-2F

Ordering Information

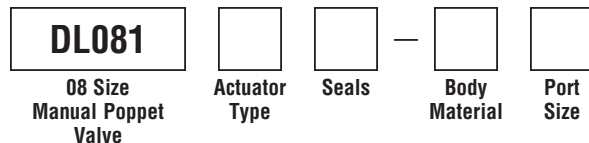

Code	Actuator Type
K	Knob (852525)
T	Stem
L	Lever
P	Lock Pin

Code	Body Material
Omit	Steel
A	Aluminum

Code	Seals / Kit No.
Omit	Nitrile / (SK08-2N)
V	Fluorocarbon / (SK08-2V)

Code	Port Size	Body Part No.
Omit		Cartridge Only
4P	1/4" NPTF	(B08-2-*4P)
6P	3/8" NPTF	(B08-2-*6P)
4T	SAE-4	(B08-2-*4T)
6T	SAE-6	(B08-2-*6T)
6B	3/8" BSPG	(B08-2-*6B)

* Add "A" for aluminum, omit for steel.



General Description

2-Way Manual Poppet Valve. The DL101 Series Valves are suited for emergency lowering applications and on-off flow applications.

Operation

The DL101 Series Valves are mechanically operated check valves. Hydraulic force on the poppet is balanced by having equal area between the poppet seat and the valve stem, allowing the poppet to be manually pulled off the seat. When released, the bias spring will return the valve poppet to its closed position. Back pressure of more than 17.3 Bar (250 PSI) will prevent the bias spring from closing the poppet and must be avoided.

Features

- Low shut-off leakage
- Cartridge design
- Pull-to-Open design
- All external parts zinc plated

Performance Curve

Pressure Drop vs. Flow (Through cartridge only)

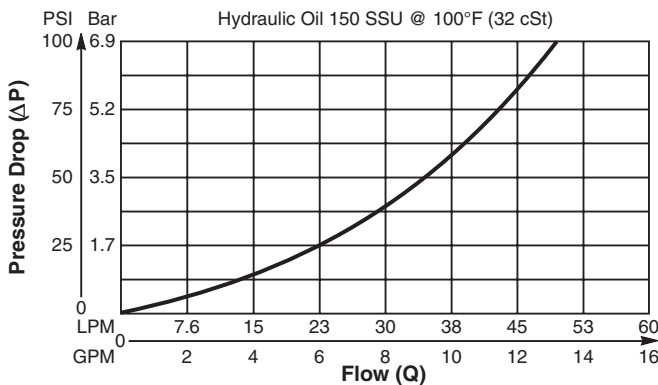

Specifications

Nominal Flow	48.8 LPM (13 GPM)
Max. Inlet Pressure	240 Bar (3500 PSI)
Leakage at 150 SSU (32 cSt)	5 drops/min. (.33 cc/min.) at 240 Bar (3500 PSI)
Max. Allowable Tankline Pressure	17.3 Bar (250 PSI)
Operating Temp. Range (Ambient)	-40°C to +93.3°C (Nitrile) (-40°F to +200°F) -31.7°C to +121.1°C (Fluorocarbon) (-25°F to +250°F)
Cartridge Material	Stem, stainless steel. All other parts hardened steel.
Filtration	ISO code 16/13, SAE Class 4 or better
Approx. Weight	0.09 kg (0.21 lbs.)
Cavity	C10-2
Form Tool	Rougher None Finisher NFT10-2F

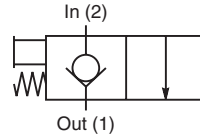
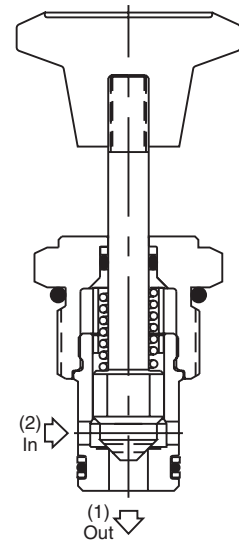

Dimensions Millimeters (Inches)

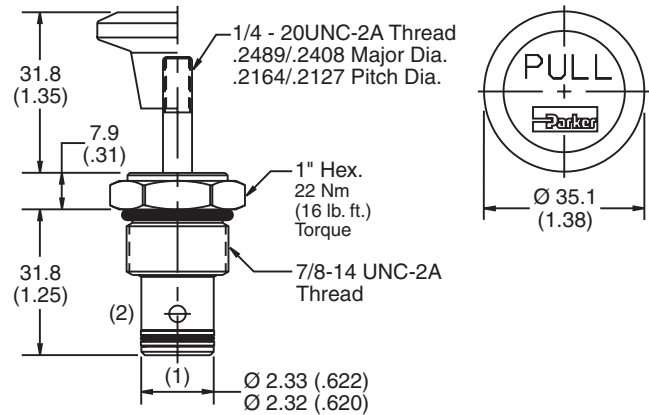

Ordering Information

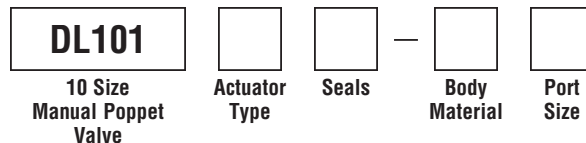

Code	Actuator Type
K	Knob (850020K)
T	Stem

Code	Body Material
Omit	Steel
A	Aluminum

Code	Seals / Kit No.
Omit	Nitrile / (SK10-2N)
V	Fluorocarbon / (SK10-2V)

Code	Port Size	Body Part No.
Omit	Cartridge Only	
4P	1/4" NPTF	(B10-2-*4P)
6P	3/8" NPTF	(B10-2-*6P)
8P	1/2" NPTF	(B10-2-*8P)
6T	SAE-6	(B10-2-*6T)
8T	SAE-8	(B10-2-*8T)
T8T	SAE-8	(B10-2-T8T)†

* Add "A" for aluminum, omit for steel.
† Steel body only.

- CV** Check Valves
- SH** Shuttle Valves
- LM** Load/Motor Controls
- FC** Flow Controls
- PC** Pressure Controls
- LE** Logic Elements
- DC** Directional Controls
- MV** Manual Valves
- SV** Solenoid Valves
- PV** Proportional Valves
- CE** Coils & Electronics
- BC** Bodies & Cavities
- TD** Technical Data

Technical Information

- CV** Check Valves
- SH** Shuttle Valves
- LM** Load/Motor Controls
- FC** Flow Controls
- PC** Pressure Controls
- LE** Logic Elements
- DC** Directional Controls
- MV** Manual Valves
- SV** Solenoid Valves
- PV** Proportional Valves
- CE** Coils & Electronics
- BC** Bodies & Cavities
- TD** Technical Data

General Description

2-Way, 2 Position, Normally Open Manual Poppet Valve.

Features

- Hardened poppet for minimal wear and greater durability
- Poppet type construction for minimal internal leakage
- Internal pilot operation provides “power leverage”
- Cavity common with solenoid operated valves
- Screw-on detent is optional
- All external parts zinc plated

Operation

In neutral position, pressure applied to port 2 creates pilot flow across the pilot seat causing poppet to lift. Flow passes from port 2 to port 1 until manual operator is pushed forcing pilot into its seat preventing pilot flow to firmly close the poppet. In neutral position, flow is restricted from port 1 to port 2.

Performance Curve

Pressure Drop vs. Flow (Through cartridge only)

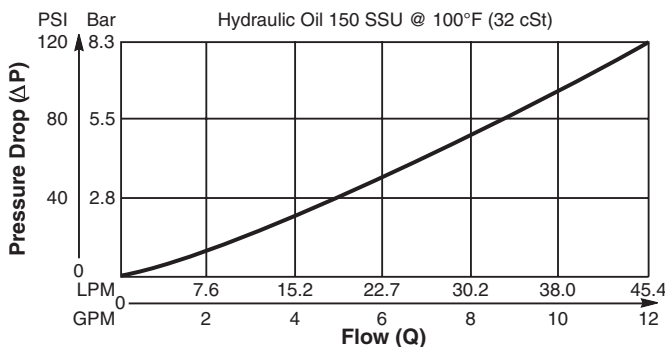

Specifications

Rated Flow	45 LPM (12 GPM)
Maximum Input Pressure @ Port 2	350 Bar (5000 PSI)
Leakage at 150 SSU (32 cSt)	0.33 ml/min. (5 drops/min.) @ 210 Bar (3000 PSI)
Cartridge Material	All parts steel. All operating parts hardened steel.
Operating Temp. Range/Seals	-40°C to +93.3°C (Nitrile, Buna-N) (-40°F to +200°F) -31.7°C to +121.1°C (Fluorocarbon) (-25°F to +250°F)
Fluid Compatibility/Viscosity	Mineral-based or synthetic with lubricating properties at viscosities of 45 to 2000 SSU (6 to 420 cSt)
Filtration	ISO code 16/13, SAE Class 4 or better
Approx. Weight	.13 kg (.31 lbs.)
Cavity	C08-2 (See BC Section for more details)

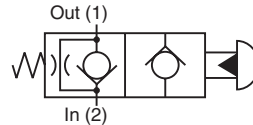
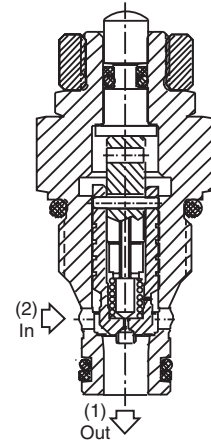

Dimensions Millimeters (Inches)

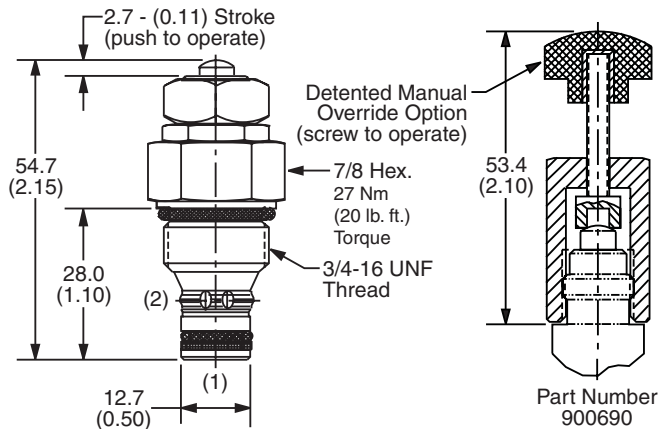

Ordering Information

GM02 12

08 Size Manual Valve	Manual Button	Filter Screen	Seals	Body Material	Port Size
Poppet Type					
Normally Open					

Code	Manual Button
0	Non-Detented (Std.)
1	Detented (With use of part #900690)

Code	Body Material
Omit	Steel
A	Aluminum

Code	Filter Screen
0	Not required
1	60 mesh screen

Code	Port Size	Body Part No.
Omit	Cartridge Only	
4P	1/4" NPTF	(B08-2-*4P)
6P	3/8" NPTF	(B08-2-*6P)
4T	SAE-4	(B08-2-*4T)
6T	SAE-6	(B08-2-*6T)
6B	3/8" BSPG	(B08-2-*6B)

Code	Seals / Kit No.
N	Nitrile, Buna-N / (SK30065N-1)
V	Fluorocarbon / (SK30065V-1)

* Add "A" for aluminum, omit for steel.



Technical Information

General Description

3-Way, 2 Position Manual Spool Valve. Designed to operate single acting cylinders, pilot circuits and uni-directional motors.

Features

- High flow capacity with reduced space requirements
- One piece cartridge housing ensures internal concentricity
- Low mechanical operating force required
- Detented option available
- All external parts zinc plated

Operation

Neutral flow is 2 to 1. Pull to shift for flow from 3 to 2.

Performance Curve

Pressure Drop vs. Flow (Through cartridge only)

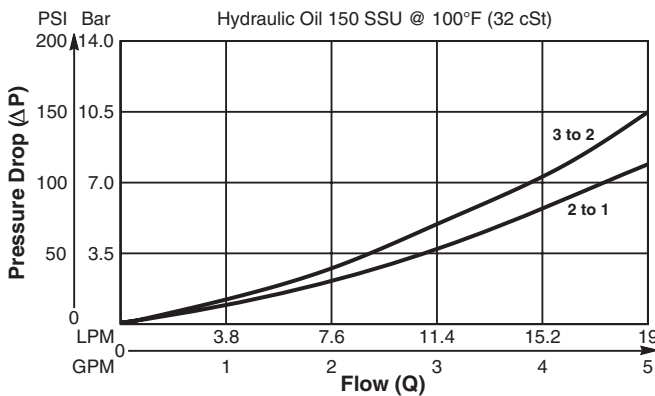

Specifications

Rated Flow	19 LPM (5 GPM)
Operating Pressure	Side Ports - 350 Bar (5000 PSI) Bottom Port - 35 Bar (500 PSI)
Max. Operating Pushing or Pulling Force Required	5 kg (11 lbs.)
Cartridge Material	All parts steel. All operating parts hardened steel.
Operating Temp. Range/Seals	-40°C to +93.3°C (Nitrile, Buna-N) (-40°F to +200°F) -31.7°C to +121.1°C (Fluorocarbon) (-25°F to +250°F)
Fluid Compatibility/Viscosity	Mineral-based or synthetic with lubricating properties at viscosities of 45 to 2000 SSU (6 to 420 cSt)
Filtration	ISO code 16/13, SAE Class 4 or better
Approx. Weight	.10 kg (.20 lbs.)
Cavity	C08-3 (See BC Section for more details)

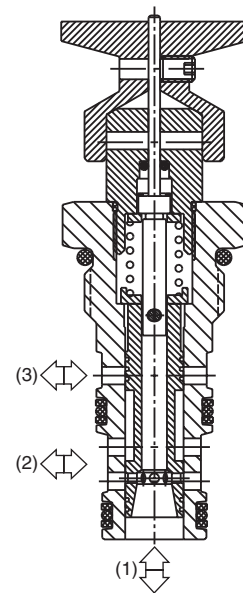
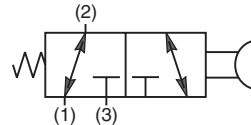
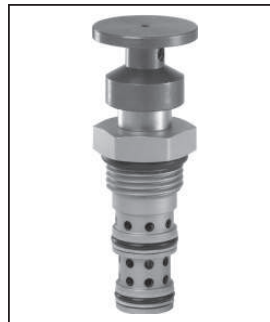

Dimensions Millimeters (Inches)

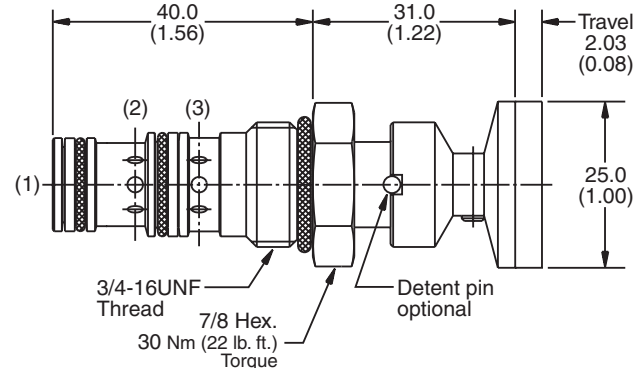

Ordering Information

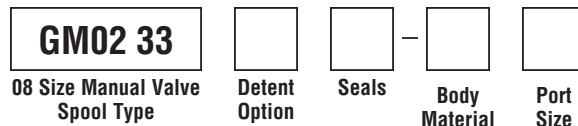

Code	Detent Option
Omit	Non-Detented (Std.)
1	Detented

Code	Body Material
Omit	Steel
A	Aluminum

Code	Seals / Kit No.
N	Nitrile, Buna-N / (SK30077N-1)
V	Fluorocarbon / (SK30077V-1)

Code	Port Size	Body Part No.
Omit	Cartridge Only	
4P	1/4" NPTF	(B08-3-*4P)
4T	SAE-4	(B08-3-*4T)
6T	SAE-6	(B08-3-*6T)
6B	3/8" BSPG	(B08-3-*6B)

* Add "A" for aluminum, omit for steel.

- CV** Check Valves
- SH** Shuttle Valves
- LM** Load/Motor Controls
- FC** Flow Controls
- PC** Pressure Controls
- LE** Logic Elements
- DC** Directional Controls
- MV** Manual Valves
- SV** Solenoid Valves
- PV** Proportional Valves
- CE** Coils & Electronics
- BC** Bodies & Cavities
- TD** Technical Data

Technical Information

- CV** Check Valves
- SH** Shuttle Valves
- LM** Load/Motor Controls
- FC** Flow Controls
- PC** Pressure Controls
- LE** Logic Elements
- DC** Directional Controls
- MV** Manual Valves
- SV** Solenoid Valves
- PV** Proportional Valves
- CE** Coils & Electronics
- BC** Bodies & Cavities
- TD** Technical Data

General Description

3-Way Rotary Spool Valve. The DM103 Series Valves are suited for any 3-way application (such as a selector function) where manual operation is desired. For additional information see Technical Tips pages MV1-MV2.

Features

- Several lever and knob options available
- Detented versions available
- Serviceable cartridge design
- All external parts zinc plated

Operation

The K, LD, and FKD options require a full 90° rotation to shift the spool from one offset position to the other. The LN and FKN options require a full 45° rotation from center to either offset position. The knob (or lever) position indicator can be positioned anywhere within the 360° circle.

Specifications

Nominal Flow	22.5 LPM (6 GPM)
Maximum Inlet Pressure	240 Bar (3500 PSI)
Degrees of Rotation	K, LD, and FKD Styles: 90° from Offset to Offset (2 positions) LN, FKN Style: 45° from center to either Offset (3 positions)
Leakage at 150 SSU (32 cSt)	164 cc/min. at 240 Bar (3500 PSI)
Cartridge Material	Stem, stainless steel. All other parts hardened steel.
Operating Temp. Range/Seals	-40°C to +93.3°C (Nitrile) (-40°F to +200°F) -31.7°C to +121.1°C (Fluorocarbon) (-25°F to +250°F)
Fluid Compatibility/Viscosity	Mineral-based or synthetic with lubricating properties at viscosities of 45 to 2000 SSU (6 to 420 cSt)
Filtration	ISO code 16/13, SAE Class 4 or better
Approx. Weight	0.11 kg (.30 lbs.)
Cavity	C10-3 (See BC Section for more details)
Form Tool	Rougher NFT10-3R Finisher NFT10-3F



DM103LD

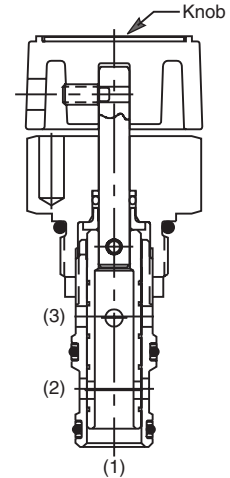
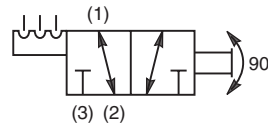

Performance Curve
Flow vs. Pressure Drop
(Through cartridge only)

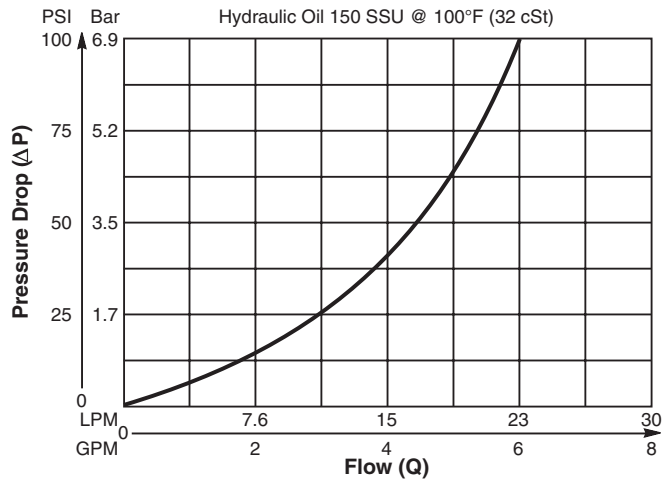

Dimensions Millimeters (Inches)

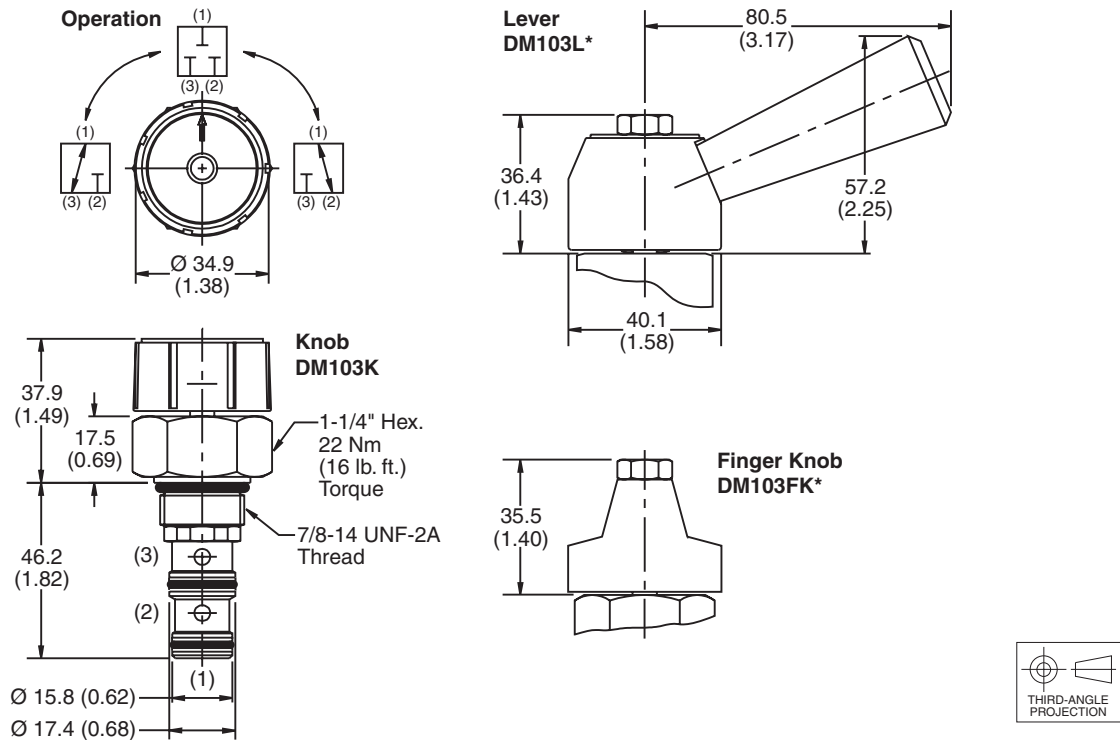

Ordering Information

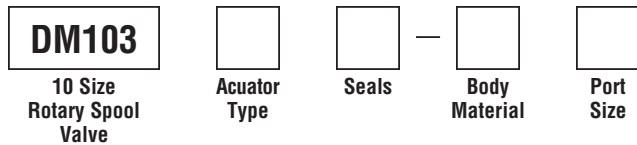

Code / Actuator Type	Diagram
K Knob	
LD Lever with 2 position detent	
LN Lever with 3 position detent	
FKD Finger Knob with 2 position detent	
FKN Finger Knob with 3 position detent	

Code	Seals / Kit. No.
Omit	Nitrile / (SK10-3N)
V	Fluorocarbon / (SK10-3V)

Code	Body Material
Omit	Steel
A	Aluminum

Code	Port Size	Body Part No.
Omit	Cartridge Only	
4P	1/4" NPTF	(B10-3-*4P)
6P	3/8" NPTF	(B10-3-*6P)
8P	1/2" NPTF	(B10-3-*8P)
4T	SAE - 4	(B10-3-*4T)
6T	SAE - 6	(B10-3-*6T)
6B	3/8" BSPG	(B10-3-6B)†
8B	1/2" BSPG	(B10-3-*8B)

* Add "A" for aluminum, omit for steel.
 † Steel body only.

Technical Information

- CV** Check Valves
- SH** Shuttle Valves
- LM** Load/Motor Controls
- FC** Flow Controls
- PC** Pressure Controls
- LE** Logic Elements
- DC** Directional Controls
- MV** Manual Valves
- SV** Solenoid Valves
- PV** Proportional Valves
- CE** Coils & Electronics
- BC** Bodies & Cavities
- TD** Technical Data

General Description

4-Way Rotary Spool Valve. The DM104 Series Valves are suited for all 4-way directional control applications where manual operation is desired.

Features

- Several lever and knob options available
- Detented versions available
- Serviceable cartridge design
- All external parts zinc plated

Operation

The K, LD, and FKD options require a full 90° rotation to shift the spool from one offset position to the other. The LN and FKN options require a full 45° rotation from center to either offset position. The knob (or lever) position indicator can be positioned anywhere within the 360° circle.

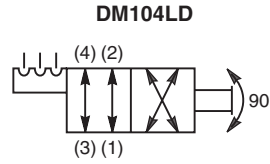
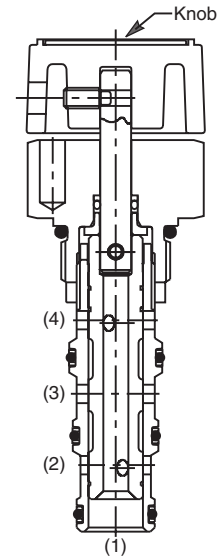
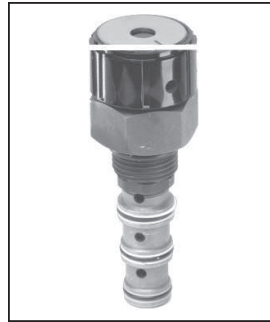

Specifications

Nominal Flow	7.5 LPM (2 GPM)
Maximum Inlet Pressure	240 Bar (3500 PSI)
Degrees of Rotation	K, LD, and FKD Styles: 90° from Offset to Offset (2 positions) LN and FKN Styles: 45° from center to either Offset (3 positions)
Leakage at 150 SSU (32 cSt)	164 cc/min. at 240 Bar (3500 PSI)
Cartridge Material	All parts steel. All operating parts hardened steel.
Operating Temp. Range/Seals	-40°C to +93.3°C (Nitrile) (-40°F to +200°F) -31.7°C to +121.1°C (Fluorocarbon) (-25°F to +250°F)
Fluid Compatibility/Viscosity	Mineral-based or synthetic with lubricating properties at viscosities of 45 to 2000 SSU (6 to 420 cSt)
Filtration	ISO code 16/13, SAE Class 4 or better
Approx. Weight	0.11 kg (.30 lbs.)
Cavity	C10-4 (See BC Section for more details)
Form Tool	Rougher NFT10-4R Finisher NFT10-4F

Performance Curve
Flow vs. Pressure Drop
(Through cartridge only)

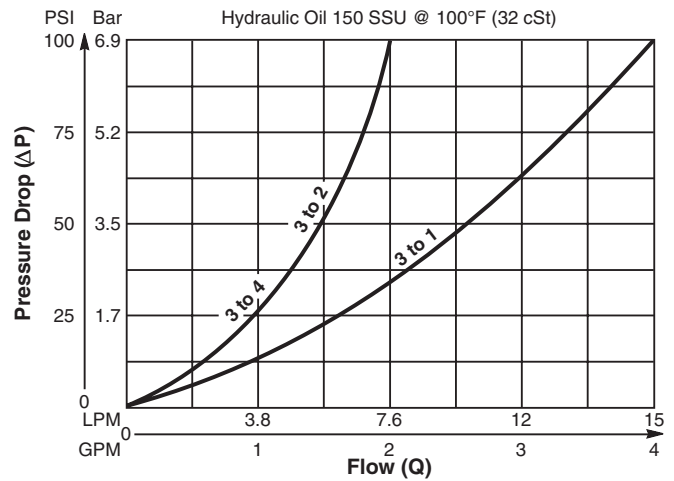

Dimensions Millimeters (Inches)

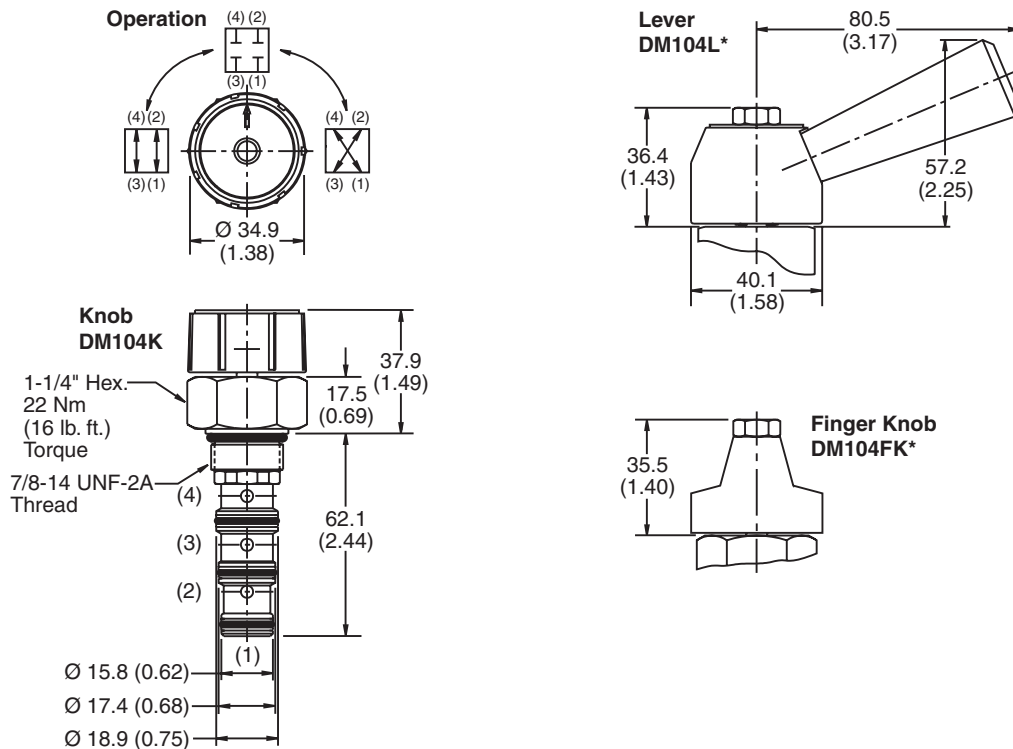

Ordering Information

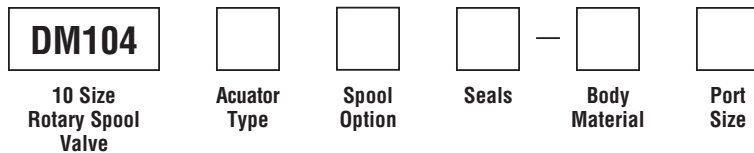

Code / Actuator Type	Diagram
K Knob	
LD Lever with 2 position detent	
LN Lever with 3 position detent	
FKD Finger Knob with 2 position detent	
FKN Finger Knob with 3 position detent	

Code / Spool Option	Diagram
1 Closed Center	
8 Tandem Center	

Code	Seals / Kit. No.
Omit	Nitrile / (SK10-4N)
V	Fluorocarbon / (SK10-4V)

Code	Body Material
Omit	Steel
A	Aluminum

Code	Port Size	Body Part No.
Omit	Cartridge Only	
6P	3/8" NPTF	(B10-4-*6P)
6T	SAE - 6	(B10-4-*6T)
8T	SAE - 8	(B10-4-*8T)
6B	3/8" BSPG	(B10-4-6B)†

* Add "A" for aluminum, omit for steel.
 † Steel body only.

Technical Information

- CV Check Valves
- SH Shuttle Valves
- LM Load/Motor Controls
- FC Flow Controls
- PC Pressure Controls
- LE Logic Elements
- DC Directional Controls
- MV Manual Valves
- SV Solenoid Valves
- PV Proportional Valves
- CE Coils & Electronics
- BC Bodies & Cavities
- TD Technical Data

General Description

4-Way, 2 Position, Reversing Manual Spool Valve. Designed to operate double acting cylinders, pilot circuits and bi-directional motors.

Features

- High flow capacity with reduced space requirements
- One piece cartridge housing ensures internal concentricity
- Low mechanical operating force required
- Detented option available
- All external parts zinc plated

Operation

Neutral, flow is 3 to 4 and 2 to 1. Push to shift for flow 3 to 2 and 4 to 1

Performance Curve

Pressure Drop vs. Flow (Through cartridge only)

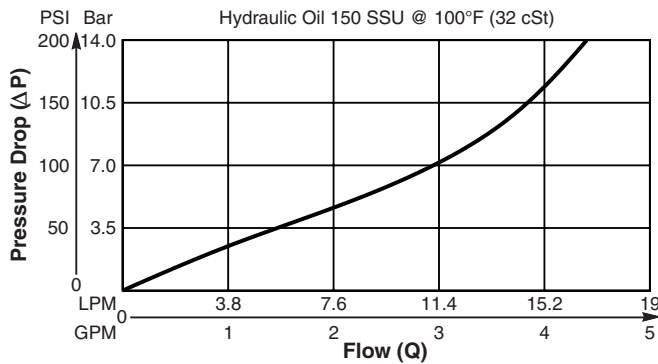

Specifications

Rated Flow	15 LPM (4 GPM)
Operating Pressure	Side Ports - 350 Bar (5000 PSI) Bottom Port - 35 Bar (500 PSI)
Max. Operating Pushing or Pulling Force Required	5 kg (11 lbs.)
Cartridge Material	All parts steel. All operating parts hardened steel.
Operating Temp. Range/Seals	-40°C to +93.3°C (Nitrile, Buna-N) (-40°F to +200°F) -31.7°C to +121.1°C (Fluorocarbon) (-25°F to +250°F)
Fluid Compatibility/Viscosity	Mineral-based or synthetic with lubricating properties at viscosities of 45 to 2000 SSU (6 to 420 cSt)
Filtration	ISO code 16/13, SAE Class 4 or better
Approx. Weight	.10 kg (.20 lbs.)
Cavity	C08-4 (See BC Section for more details)

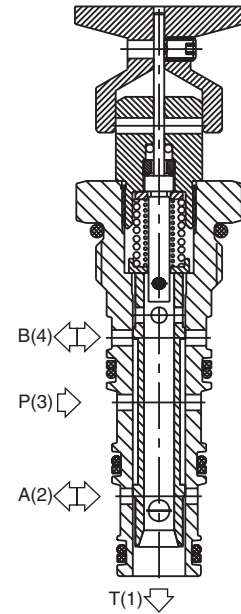
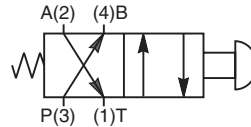

Dimensions Millimeters (Inches)

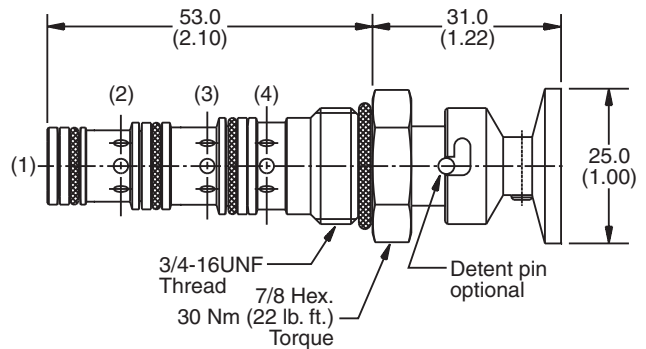

Ordering Information

GM02 40XS

08 Size Manual Valve Detent Option Seals Body Material Port Size
Spool Type Reversing

Code	Detent Option
Omit	Non-Detented (Std.)
1	Detented

Code	Body Material
Omit	Steel
A	Aluminum

Code	Seals / Kit No.
N	Nitrile, Buna-N / (SK30078N-1)
V	Fluorocarbon / (SK30078V-1)

Code	Port Size	Body Part No.
Omit	Cartridge Only	
4T	SAE-4	(B08-4-*4T)
6T	SAE-6	(B08-4-*6T)
6B	3/8" BSPG	(B08-4-*6B)

* Add "A" for aluminum, omit for steel.

Technical Information

General Description

4-Way, 2 Position, Normally Closed Manual Spool Valve. Designed to operate double acting cylinders, pilot circuits and bi-directional motors.

Features

- High flow capacity with reduced space requirements
- One piece cartridge housing ensures internal concentricity
- Low mechanical operating force required
- Detented option available
- All external parts zinc plated

Operation

Neutral, all ports blocked. Push to shift for flow 3 to 2 and 4 to 1.

Performance Curve

Pressure Drop vs. Flow (Through cartridge only)

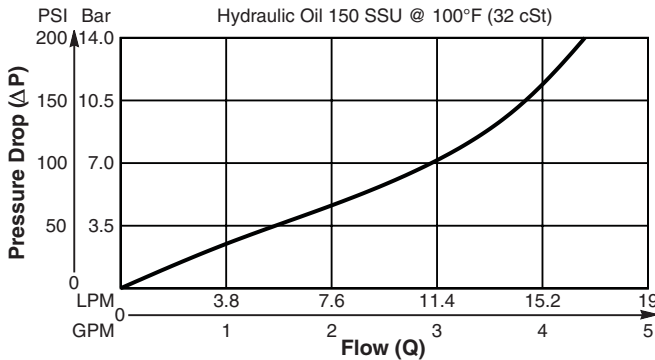

Specifications

Rated Flow	15 LPM (4 GPM)
Operating Pressure	Side Ports - 350 Bar (5000 PSI) Bottom Port - 35 Bar (500 PSI)
Max. Operating Pushing or Pulling Force Required	5 kg (11 lbs.)
Cartridge Material	All parts steel. All operating parts hardened steel.
Operating Temp. Range/Seals	-40°C to +93.3°C (Nitrile, Buna-N) (-40°F to +200°F) -31.7°C to +121.1°C (Fluorocarbon) (-25°F to +250°F)
Fluid Compatibility/Viscosity	Mineral-based or synthetic with lubricating properties at viscosities of 45 to 2000 SSU (6 to 420 cSt)
Filtration	ISO code 16/13, SAE Class 4 or better
Approx. Weight	.12 kg (.25 lbs.)
Cavity	C08-4 (See BC Section for more details)

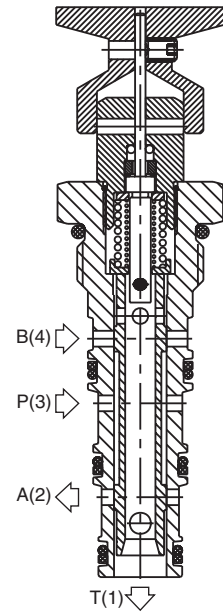
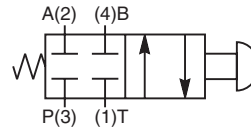

Dimensions Millimeters (Inches)

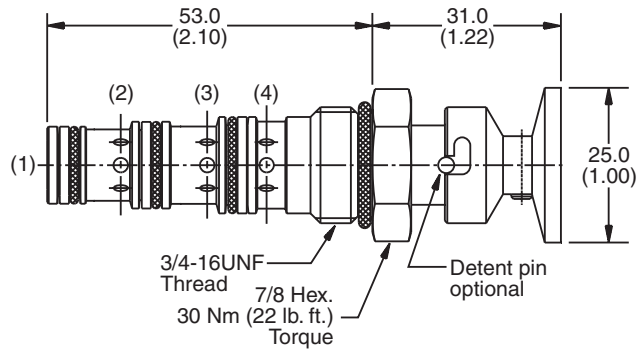

Ordering Information

GM02 40CS

08 Size Manual Valve Detent Option Seals Body Material Port Size
Spool Type Normally Closed

Code	Detent Option
Omit	Non-Detented (Std.)
1	Detented

Code	Body Material
Omit	Steel
A	Aluminum

Code	Seals / Kit No.
N	Nitrile, Buna-N / (SK30078N-1)
V	Fluorocarbon / (SK30078V-1)

Code	Port Size	Body Part No.
Omit	Cartridge Only	
4T	SAE-4	(B08-4-*4T)
6T	SAE-6	(B08-4-*6T)
6B	3/8" BSPG	(B08-4-*6B)

* Add "A" for aluminum, omit for steel.

- CV** Check Valves
- SH** Shuttle Valves
- LM** Load/Motor Controls
- FC** Flow Controls
- PC** Pressure Controls
- LE** Logic Elements
- DC** Directional Controls
- MV** Manual Valves
- SV** Solenoid Valves
- PV** Proportional Valves
- CE** Coils & Electronics
- BC** Bodies & Cavities
- TD** Technical Data

Technical Information

- CV Check Valves
- SH Shuttle Valves
- LM Load/Motor Controls
- FC Flow Controls
- PC Pressure Controls
- LE Logic Elements
- DC Directional Controls
- MV Manual Valves
- SV Solenoid Valves
- PV Proportional Valves
- CE Coils & Electronics
- BC Bodies & Cavities
- TD Technical Data

General Description

4-Way, 3 Position, Closed Center Manual Spool Valve. Designed to operate double acting cylinders, pilot circuits and bi-directional motors.

Features

- High flow capacity with reduced space requirements
- One piece cartridge housing ensures internal concentricity
- Low mechanical operating force required
- Detented option available
- All external parts zinc plated

Operation

Push to shift for flow 3 to 2 and 4 to 1. Pull to shift for flow 3 to 4 and 2 to 1.

NOTE:

This series will be available January 1, 2011.

Specifications

Rated Flow	C1 17 LPM (4.5 GPM) C2 15 LPM (4.0 GPM) C4 19 LPM (5.0 GPM) C9 15 LPM (4.0 GPM)
Operating Pressure	Side Ports - 350 Bar (5000 PSI) Bottom Port - 35 Bar (500 PSI)
Max. Operating Pushing or Pulling Force Required	5 kg (11 lbs.)
Cartridge Material	All parts steel. All operating parts hardened steel.
Operating Temp. Range/Seals	-45°C to +93.3°C ("D"-Ring) (-50°F to +200°F) -31.7°C to +121.1°C (Fluorocarbon) (-25°F to +250°F)
Fluid Compatibility/Viscosity	Mineral-based or synthetic with lubricating properties at viscosities of 45 to 2000 SSU (6 to 420 cSt)
Filtration	ISO code 16/13, SAE Class 4 or better
Approx. Weight	.12 kg (.25 lbs.)
Cavity	C08-4 (See BC Section for more details)

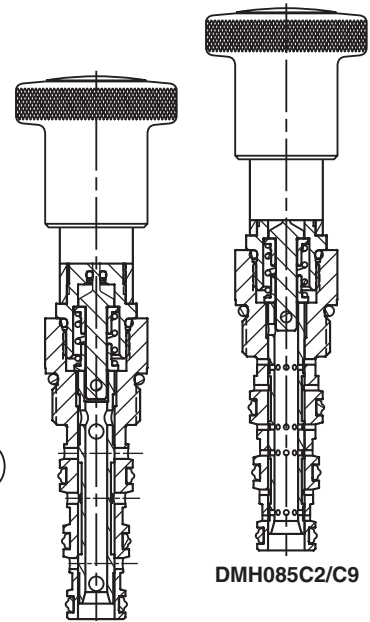
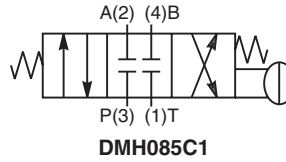

Dimensions Millimeters (Inches)

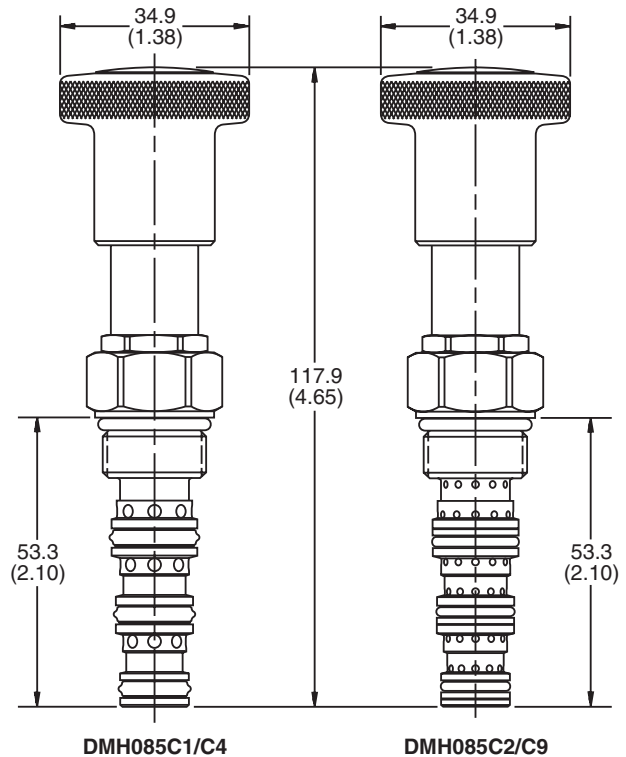

Note: "D"-Rings are standard on all spool configurations, but optional Buna/Fluorocarbon configurations as shown on the C2/C9 drawing are also available.

Performance Curves

Pressure Drop vs. Flow (Through cartridge only)

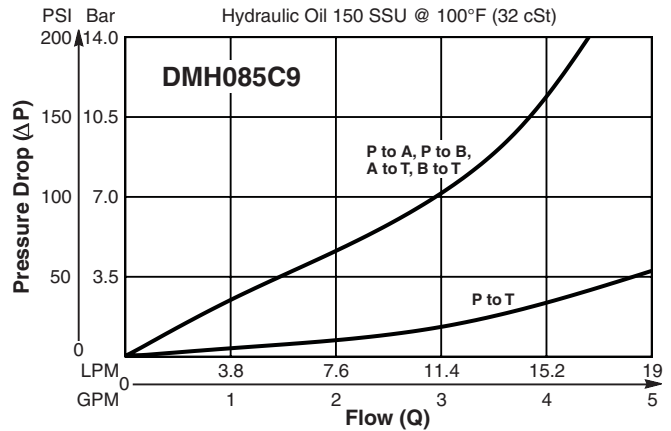
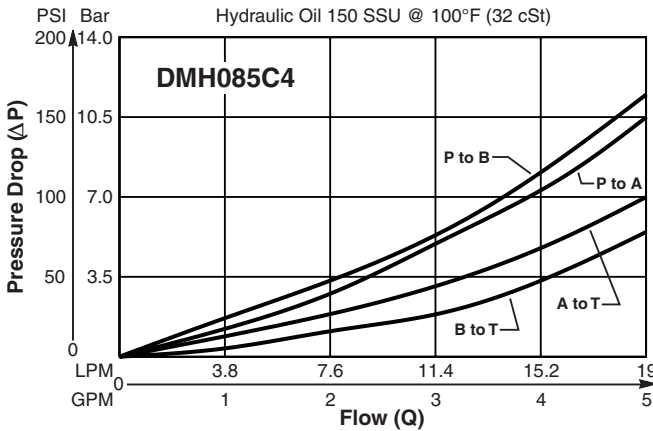
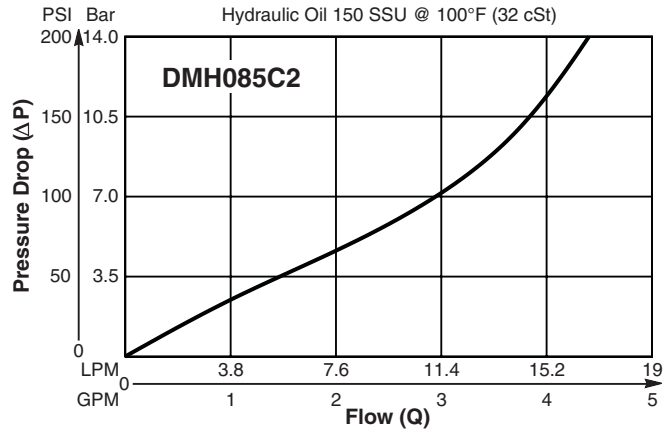
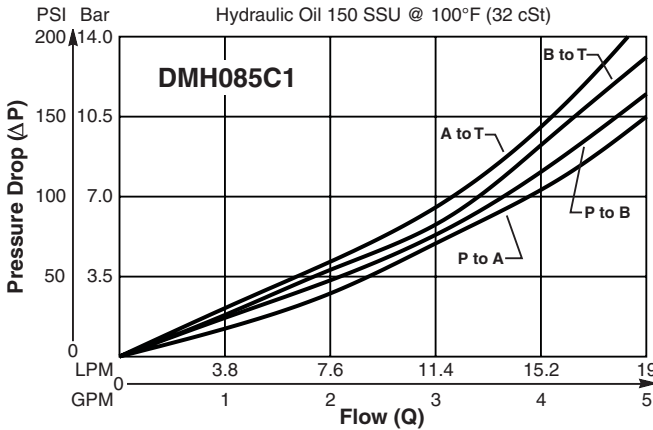

Ordering Information

DMH085

08 Size, 4-Way Spool Type Manual Valve Style Detent Option Seals Body Material Port Size

NOTE:
 This series will be available
 January 1, 2011.

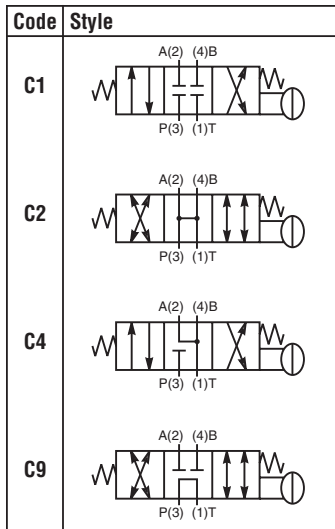

Code	Detent Option
Omit	Non-Detented (Std.)
D	Detented

Code	Body Material
Omit	Steel
A	Aluminum

Code	Seals / Kit No.
Omit	"D"-Ring / (SK08-2)
N	Nitrile / (SK08-2N)
V	Fluorocarbon / (SK08-2V)

Code	Port Size	Body Part No.
Omit	Cartridge Only	
4T	SAE-4	(B08-4-*4T)
6T	SAE-6	(B08-4-*6T)
6B	3/8" BSPG	(B08-4-*6B)

* Add "A" for aluminum, omit for steel.



- CV**
Check Valves
- SH**
Shuttle Valves
- LM**
Load/Motor Controls
- FC**
Flow Controls
- PC**
Pressure Controls
- LE**
Logic Elements
- DC**
Directional Controls
- MV**
Manual Valves
- SV**
Solenoid Valves
- PV**
Proportional Valves
- CE**
Coils & Electronics
- BC**
Bodies & Cavities
- TD**
Technical Data

Contents

Pressure Control Valves

CV	Check Valves
SH	Shuttle Valves
LM	Load/Motor Controls
FC	Flow Controls
PC	Pressure Controls
LE	Logic Elements
DC	Directional Controls
MV	Manual Valves
SV	Solenoid Valves
PV	Proportional Valves
CE	Coils & Electronics
BC	Bodies & Cavities
TD	Technical Data

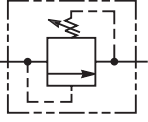
SERIES	CAVITY	DESCRIPTION	FLOW LPM/GPM	PRESSURE BAR/PSI	PAGE NO.
RELIEF VALVES					
DIRECT ACTING					
					
RDH042	C04-2	Direct Acting Relief, Poppet Type	3.8/1	350/5000	PC7-PC8
★ RDH081	C08-2	Direct Acting Relief, Ball Type	1.9/5	380/5500	PC9-PC10
RDH082	C08-2	Direct Acting Relief, Poppet Type	30/8	380/5500	PC11-PC12
★ RDH101	C10-2	Direct Acting Relief, Ball Type	1.9/5	380/5500	PC13-PC14
A02A2	C08-2	Direct Acting Relief, Ball Type	6/1.6	420/6000	PC15-PC16
A02B2	C08-2	Direct Acting Relief, Poppet Type	8/30	420/6000	PC17-PC18
★ RD102	C10-2	Direct Acting Relief, Poppet Type	38/10	250/3600	PC19-PC20
A04B2	C10-2	Direct Acting Relief, Poppet Type	100/26	420/6000	PC21-PC22
A04B2*CE	C10-2	Direct Acting Relief, Poppet Type*			PC23-PC24
A04C2	C10-2	Direct Acting Relief, Spool Type	200/53	100/1450	PC25-PC26
<i>*CE marked, PED Compliant</i>					
DIFFERENTIAL AREA					
RDH083	C08-2	Direct Acting Differential Area Relief	45/12	350/5000	PC27-PC28
★ RDH103	C10-2	Direct Acting Differential Area Relief	75/20	350/5000	PC29-PC30
★ RDCH103	C10-2	Direct Acting Differential Relief Assembly with Reverse Check	60/16	380/5500	PC31-PC32
RD163	C16-2	Direct Acting Differential Area Relief	151/40	210/3000	PC33-PC34
PILOT OPERATED					
★ RAH081	C08-2	Pilot Operated Spool Type	75.8/20	350/5000	PC35-PC36
★ RAH101	C10-2	Pilot Operated Spool Type	113/30	350/5000	PC37-PC38
RAH121	C12-2	Pilot Operated Spool Type	190/50	350/5000	PC39-PC40
RAH161	C16-2	Pilot Operated Spool Type	303/80	380/5500	PC41-PC42
A06G2	C16-2	Pilot Operated Spool Type	400/106	420/6000	PC43-PC44
RAH201	C20-2	Pilot Operated Spool Type	379/100	350/5000	PC45-PC46
A04K2	C10-2	Pilot Operated Spool Type Kick Down	160/42	420/6000	PC47-PC48
SOLENOID OPERATED					
AS04G2	C10-2	Solenoid Operated Unloading Relief	90/24	220/3200	PC49-PC50
<i>*See page PC49 for symbol</i>					
VENTABLE					
★ RAH101V	C10-3	Pilot Operated Vented Relief	68/18	380/5500	PC51-PC52
A04H3	C10-3S	Pilot Operated Vented Relief	190/50	420/6000	PC53-PC54
A06H3	C16-3S	Pilot Operated Vented Relief	400/106	420/6000	PC55-PC56
CROSS-OVER					
XR101	C10-2	Direct Acting Cross-over Relief	61/16	245/3500	PC57-PC58
A04J2	C10-2	Direct Acting Cross-over Relief	120/32	350/5000	PC59-PC60
A04J2*CE	C10-2	Direct Acting Cross-over Relief*	120/32	350/5000	PC61-PC62
★ XRDH101		Direct Acting Cross-over Relief	75/20	380/5500	PC63-PC64
★ XRDH102		Direct Acting Cross-over Relief with Anti-Cav Check	60/16	380/5500	PC65-PC66
★ XRDH103		Direct Acting Cross-over Relief, Motor Mount	75/20	380/5500	PC67-PC68
<i>*CE marked, PED Compliant</i>					
UNLOADING					
RU101	C10-3	Direct Acting Unloading	3.75/1	210/3000	PC69-PC70
*M04A4J	C10-4	Direct Acting Piloting Unloading	2/0.53	420/6000	PC71-PC72
<i>*See page PC71 for symbol</i>					
PILOT OPERATED WITH REVERSE CHECK					
A06P2	C16-2	Pilot Operated Poppet Type	400/106	420/6000	PC73-PC74
SEQUENCE VALVES					
PILOT OPERATED					
★ SVH081	C08-3	Pilot Operated, Int. Pilot, Ext. Drain	45/12	350/5000	PC75-PC76
★ SVH101	C10-3	Pilot Operated, Int. Pilot, Ext. Drain	56.3/15	350/5000	PC77-PC78
SVH161	C16-3	Pilot Operated, Int. Pilot, Ext. Drain	151.6/40	350/5000	PC79-PC80
★ SVH102	C10-3	Pilot Operated, Ext. Pilot, Int. Drain	56.3/15	350/5000	PC81-PC82
SVH162	C16-3	Pilot Operated, Ext. Pilot, Int. Drain	151.6/40	350/5000	PC83-PC84
★ SVCH101		Pilot Operated with Reverse Check Assy	56/15	380/5500	PC85-PC86

★ Denotes New Winner's Circle Product Line.

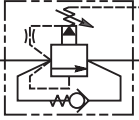
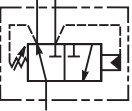
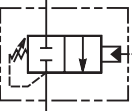
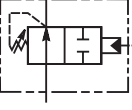
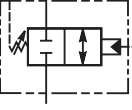
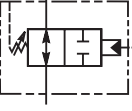
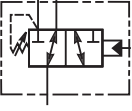
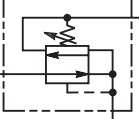
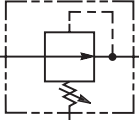
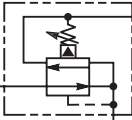

	SERIES	CAVITY	DESCRIPTION	FLOW LPM/GPM	PRESSURE BAR/PSI	PAGE NO.	
SEQUENCE VALVES							
	Pilot Operated (Continued)						
	B04D3	C10-3S	Pilot Operated, Reverse Check, Ext. Drain	120/32	420/6000	PC87-PC88	
	B04C3	C10-3S	Pilot Operated, Kick Down	160/42	420/6000	PC89-PC90	
<hr/>							
	DIRECT ACTING						
	B02E3F	C08-3	Direct Acting, 2P-3W, Int. Pilot, Int. Drain	30/8	420/6000	PC91-PC92	
	B04E3	C10-3	Direct Acting, 2P-3W, Int. Pilot, Int. Drain	50/13	420/6000	PC93-PC94	
☆	SV103	C10-3	Direct Acting, 2P-3W, Int. Pilot, Ext. Drain	56/15	250/3600	PC95-PC96	
<hr/>							
	☆	SV105	C10-3	Direct Acting, 2P-2W, NC, Ext. Pilot, Int. Drain	38/10	250/3600	PC97-PC98
	B04F3	C10-3	Direct Acting, 2P-2W, NC, Ext. Pilot, Int. Drain	34/9	420/6000	PC99-PC100	
	B04G3	C10-3	Direct Acting, 2P-2W, NO, Ext. Pilot, Int. Drain	40/10.6	420/6000	PC101-PC102	
	<hr/>						
	B04H4	C10-4	Direct Acting, 2P-2W, NC, Ext. Pilot, Ext. Drain	47/12	420/6000	PC103-PC104	
	☆	SV104	C10-4	Direct Acting, 2P-2W, NO, Ext. Pilot, Ext. Drain	30/8	250/3600	PC105-PC106
	B04J4	C10-4	Direct Acting, 2P-2W, NO, Ext. Pilot, Ext. Drain	47/12	420/6000	PC107-PC108	
	<hr/>						
	B04K4	C10-4	Direct Acting, 2P-3W, NO, Ext. Pilot, Int. Drain	42/11	420/6000	PC109-PC110	
	<hr/>						
REDUCING VALVES							
	DIRECT ACTING						
	C02A3	C08-3	Direct Acting Reducing/Relieving	20/5	420/6000	PC111-PC112	
☆	PR103	C10-3	Direct Acting Reducing/Relieving	56/13	210/3000	PC113-PC114	
<hr/>							
	PILOT OPERATED						
	☆	PRH082	C08-3	Pilot Operated Reducing	30/8	350/5000	PC115-PC116
	☆	PRH102	C10-3	Pilot Operated Reducing	56.3/15	350/5000	PC117-PC118
	PRH122	C12-3	Pilot Operated Reducing	113.7/30	350/5000	PC119-PC120	
	PRH162	C16-3	Pilot Operated Reducing	150/40	350/5000	PC121-PC122	
<hr/>							
	☆	PRH081	C08-3	Pilot Operated Reducing/Relieving	30/8	350/5000	PC123-PC124
	☆	PRH101	C10-3	Pilot Operated Reducing/Relieving	56.3/15	350/5000	PC125-PC126
	PRH121	C12-3	Pilot Operated Reducing/Relieving	113.7/30	350/5000	PC127-PC128	
	PRH161	C16-3	Pilot Operated Reducing/Relieving	150/40	350/5000	PC129-PC130	
☆	PRCH101		Pilot Operated Reducing/Relieving with Reverse Check	56/15	380/5500	PC131-PC132	

☆ Denotes New Winner's Circle Product Line.



CV
Check Valves

SH
Shuttle Valves

LM
Load/Motor Controls

FC
Flow Controls

PC
Pressure Controls

LE
Logic Elements

DC
Directional Controls

MV
Manual Valves

SV
Solenoid Valves

PV
Proportional Valves

CE
Coils & Electronics

BC
Bodies & Cavities

TD
Technical Data

CV

Check Valves

SH

Shuttle Valves

LM

Load/Motor Controls

FC

Flow Controls

PC

Pressure Controls

LE

Logic Elements

DC

Directional Controls

MV

Manual Valves

SV

Solenoid Valves

PV

Proportional Valves

CE

Coils & Electronics

BC

Bodies & Cavities

TD

Technical Data

INTRODUCTION

This technical tips section is designed to help familiarize you with the Parker line of Pressure Controls. In this section we highlight new products to this catalog as well as some design features of our pressure control line. In addition we present common options available to help you in selecting products for your application. Finally we give a brief synopsis of the operation and applications of the various product offered in this section.

NEW PRODUCTS

There are several new additions and product improvements to our Pressure Controls product line.

Here are just some of the design features and advantages to the "Winner's Circle" product line.

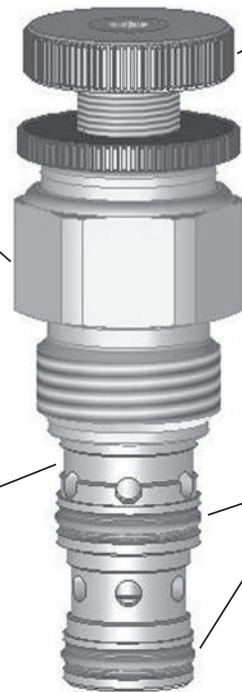

Yellow Zinc Coating
Steel adapters are coated with yellow zinc di-chromate for protection from salt spray.

Variety of Adjustments
Pressure controls are offered in screw adjust, knob adjust, fixed and tamper resistant configurations.

High Pressure Design
Pilot operated valves are rated to 350 Bar (5000 PSI) for use at elevated pressure.

"D"-Ring
Standard 4301 Polyurethane Seal eliminates the need for backup rings providing easier manifold installation. (For more information on "D"-Ring see Technical Data Section)

Crimp Design
Fold over crimp provides secure holding and eliminates the need for adhesive.

Guided Pilot
Pilot is fully guided providing a more consistent reseat.

Internal Screen
A small internal screen protects the pilot orifice and spring chamber from debris.

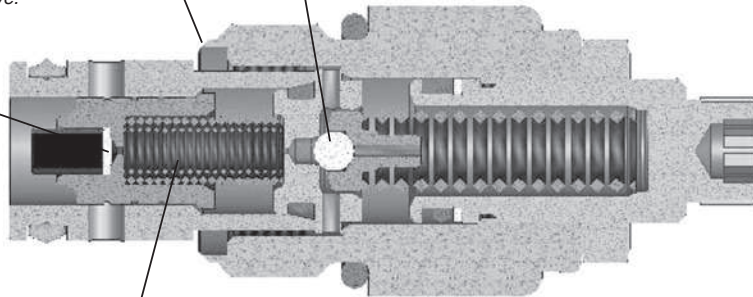

High Rate Bias Spring
Pilot operated reducing and sequence valves are designed with a high rate bias spring pressure, enhancing stability.

Low Profile Adapter
The low profile shape of the pilot operated pressure controls reduces the manifold clearance required.

COMMON OPTIONS

As you will see, Parker offers a variety of Pressure Control products. As such, some of the options mentioned below may not be available on all valves. Consult the model coding and dimensions for each valve for specifics. Here are some of the common options available.

Adjustment Types: Parker offers four primary types of adjustments for most of the pressure control products. Samples of these types are shown below. Please note all options may not be available for all valves. Consult the individual catalog pages for more details.

Screw Adjustment - Valve can be adjusted with an allen wrench. Lock nut included to maintain desired setting after adjustment. This is the most common adjustment option available on most Parker products.

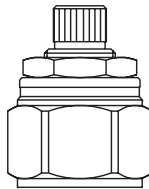

Knob Adjustment - An aluminum knob is added to the standard screw adjustment. A lock knob is provided to help maintain the desired setting after adjustment. Parker offers knob conversion kits for most pressure control valves. For kit numbers consult individual valve pages.

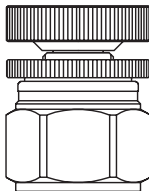

Fixed Style - In most cases, the Fixed Style product is a screw adjustable product with a steel collet threaded over the screw adjustment. These valves are preset at the factory.

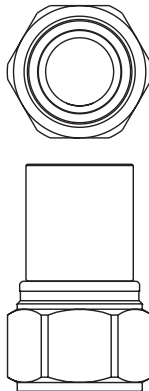

Tamper Resistant - The tamper resistant option is a screw adjustable valve with a steel cap installed to conceal the adjustment. The cap is designed so that the internal edges clamp into the groove of the valve adapter. Once the cap is installed, it cannot be removed without damaging the cap and the valve. When a valve is ordered with the tamper resistant option, it will be preset at the factory, and the cap will be included in a separate plastic bag to allow for fine tuning at the customer site. Parker offers tamper resistant cap conversion kits for most pressure control valves. For kit numbers consult individual valve pages.

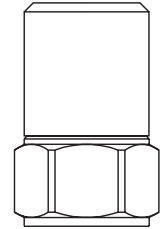

Seals: The Winner's Circle products feature a standard 4301 Polyurethane "D"-Ring. The "D"-Ring eliminates the need for backup rings. The majority of the products are available in Nitrile or Fluorocarbon Seals. You should match the seal compatibility to the temperature and fluid being used in your application.

Pressure Range: Parker offers a range of spring settings for the Pressure Control product line. You want to choose the setting that best meets the operating range. The model callout is equivalent to the maximum setting (in psi) of the spring divided by 100 (i.e. 50 = 5000 psi).

CV

Check Valves

SH

Shuttle Valves

LM

Load/Motor Controls

FC

Flow Controls

PC

Pressure Controls

LE

Logic Elements

DC

Directional Controls

MV

Manual Valves

SV

Solenoid Valves

PV

Proportional Valves

CE

Coils & Electronics

BC

Bodies & Cavities

TD

Technical Data

CV

Check Valves

SH

Shuttle Valves

LM

Load/Motor Controls

FC

Flow Controls

PC

Pressure Controls

LE

Logic Elements

DC

Directional Controls

MV

Manual Valves

SV

Solenoid Valves

PV

Proportional Valves

CE

Coils & Electronics

BC

Bodies & Cavities

TD

Technical Data

PRODUCT TYPES / APPLICATIONS

Direct Acting Relief Valves

Direct acting relief valves are designed for fast response in intermittent duty applications. They are often used as an economical solution to clip pressure spikes. The poppet design allows for low leakage.

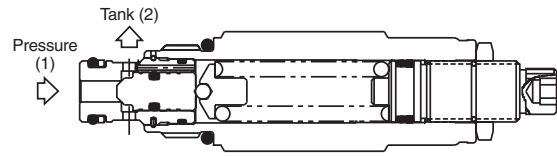
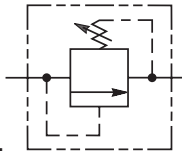

OPERATION - The valve poppet is held against the seat by the spring force. Inlet pressure on the nose (port 1) of the poppet acts against the spring force to unseat the poppet at the valve setting and allow flow to pass to tank. Since the pressure is working directly on the spring, this valve is very fast responding. It is not the best choice for system pressure regulation as it is slightly noisier than pilot operated relief valves and has higher pressure rise. *Note:* Any backpressure on port 2 would be additive to the spring setting.

Differential Area Relief Valves

Differential area relief valves also are also best suited for intermittent applications where fast response is critical. These valves are often used as cross-over relief valves to chop pressure spikes. Due to their design, they generally can handle a larger flow rate and have a lower pressure rise than the standard directing acting relief. The poppet design allows for low leakage.

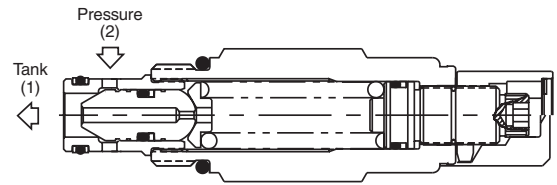
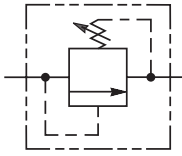

OPERATION - Pressure on the inlet (port 2) of the valve acts on the differential area of the poppet (difference between the O.D. of the poppet and the seat diameter) to produce a force which is opposed by the spring force. When pressure reaches the valve setting, the poppet is pushed off its seat, permitting flow to tank. *Note:* Any backpressure on port 1 would be additive to the spring setting.

Pilot Operated Relief

Pilot operated relief valves are designed for continuous duty applications. Due to their stability and low pressure rise, the pilot operated relief is the best option for setting the pressure of a hydraulic system.

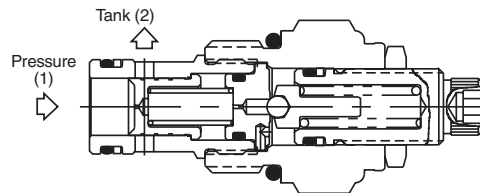
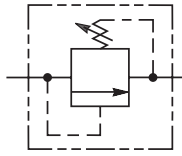

OPERATION - When inlet pressure at the nose (port 1) exceeds the valve setting, the pilot ball unseats. The pilot flow creates a pressure imbalance across the main spool causing the spool to move and allowing flow from inlet (port 1) to tank (port 2.) *Note:* Any backpressure on port 2 would be additive to the spring setting.

Ventable Pilot Operated Relief

Ventable relief valves are a unique type of pilot operated relief. With this valve, you can control the pressure setting with the internal adjustment as well as via remote circuit. These valves are ideal in circuits where multiple pressures are needed.

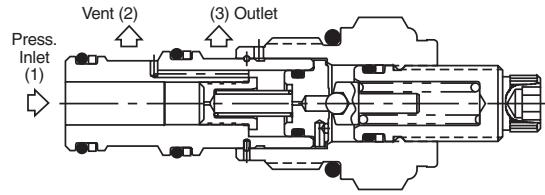
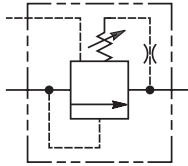

OPERATION - This valve can be controlled by the adjustment setting on the valve, or a remote circuit via the vent line. When the vent line is used, the smaller of the two pressure settings will determine the valve setting. In other words, if the pressure setting of the remote circuit is less than the adjusted setting, then the valve will relieve at the remote setting. If the pressure setting of the remote circuit is greater than the adjusted setting, then the valve will relieve at the adjusted setting. With the vent port (port 2) blocked, the valve operates like a standard pilot operated relief valve. Thus, a solenoid valve could be used on the vent port to select control between this valve another remote valve.

Dual Crossover Relief Valves

Dual crossover relief valves provide pressure surge protection for double acting hydraulic actuators. For best results, you always want to install the valve as close to the actuator as possible. The dual crossover feature can be achieved in two different methods. One way is to manifold two Differential Area Relief Valves into a single body. Parker offers three versions of this two cartridge arrangement. The advantage gained is higher flows can be pushed through this arrangement. The second method is to combine this dual function into a single cartridge. The single cartridge arrangement reduces cost considerably of the total package. In addition, a standard common cavity line body can be used instead of a special two body arrangement. The operation for the single cartridge style is shown below.

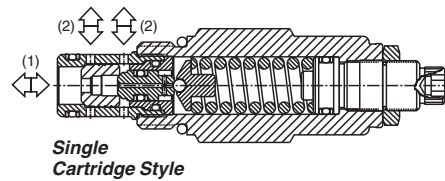
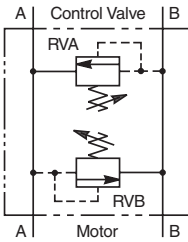

Single Cartridge Style

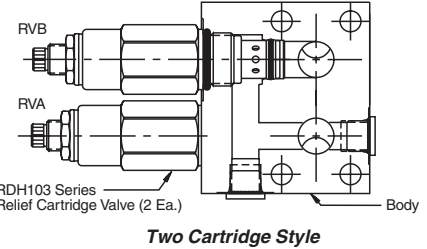

Two Cartridge Style

OPERATION - Pressure at port 1 acts on the spool to produce a force which is opposed by the spring setting. When pressure reaches the valve setting, the spool and poppet move relieving flow from port 1 to port 2. When port 2 is pressurized, the pressure acts on the differential area poppet to produce a force which is opposed by the spring force. When the pressure reaches the valve setting, the poppet is pushed off of its seat, relieving flow from port 2 to port 1. *Note:* Due to the construction and flow paths through the valve, the relief pressure settings may vary by approximately 300 psi from one direction to the other.

Differential Area Unloading Relief Valve

Unloading valves are differential area relief valves that can also be fully dumped or unloaded via a remote signal. They are best suited for low flow accumulator unloading circuits. They provide a fixed percentage between load and unload pressures. This pilot valve would generally be used in conjunction with a logic element.

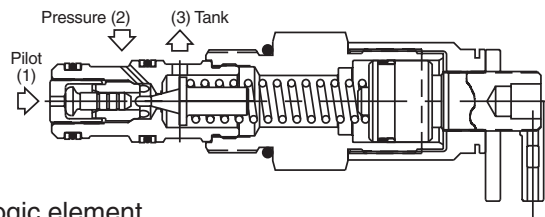
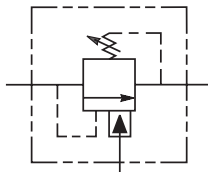

OPERATION - The fixed differential is provided by the pilot piston which has greater area than the dart seat. With its greater area, the piston is able to hold the dart off its seat, permitting flow from pressure to tank, until pressure on the pilot piston falls below the fixed percentage of the valve settings.

- CV
- Check Valves
- SH
- Shuttle Valves
- LM
- Load/Motor Controls
- FC
- Flow Controls
- PC
- Pressure Controls
- LE
- Logic Elements
- DC
- Directional Controls
- MV
- Manual Valves
- SV
- Solenoid Valves
- PV
- Proportional Valves
- CE
- Coils & Electronics
- BC
- Bodies & Cavities
- TD
- Technical Data

- CV Check Valves
- SH Shuttle Valves
- LM Load/Motor Controls
- FC Flow Controls
- PC Pressure Controls
- LE Logic Elements
- DC Directional Controls
- MV Manual Valves
- SV Solenoid Valves
- PV Proportional Valves
- CE Coils & Electronics
- BC Bodies & Cavities
- TD Technical Data

Pilot Operated Reducing Valve

Pilot operated pressure reducing valves can be used to reduce the pressure in a leg of the circuit lower than system pressure. Thus, they can be used to provide protection to downstream components from higher pressures.

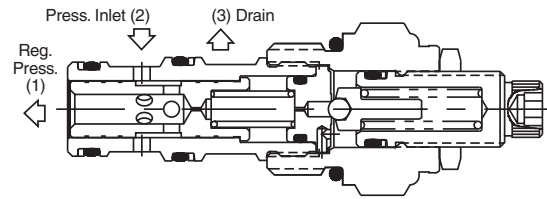
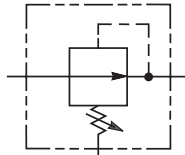

OPERATION - The pilot section controls the valve setting when reducing. As pressure at the regulated port exceeds the valve setting, the pilot ball is unseated. The pilot flow creates a pressure imbalance across the main spool causing the spool to throttle in order to maintain constant downstream pressure. The normally open design will allow flow to pass from inlet to reduced port with the only restriction being the pressure drop.

Pressure Reducing / Relieving Valves

Pressure reducing / relieving valves can be used to reduce the pressure in a leg of the circuit lower than system pressure. The valve also acts as a relief valve, relieving any shocks or surges that occur between the regulated port and the actuator. When the valve is in the relieving mode, the inlet port is blocked. Parker offers pressure reducing/relieving valves in both pilot operated and directing acting styles. The direct acting version is generally used in static applications where response is critical, or leakage is a concern.

Pilot Operated

OPERATION - The pilot section controls the valve setting when reducing. As pressure at the regulated port exceeds the valve setting, the pilot ball is unseated. The pilot flow creates a pressure imbalance across the main spool causing the spool to throttle in order to maintain constant downstream pressure. A shock or surge at the regulated port shifts the spool, relieving flow to tank.

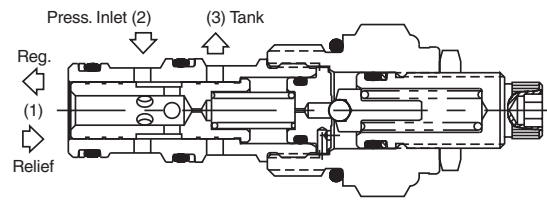
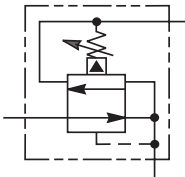

Direct Acting

OPERATION - As pressure at the regulated port exceeds the valve setting, the valve throttles or closes in order to maintain constant downstream pressure. A shock or surge at the regulated port further shifts the spool, relieving flow to tank. This valve is not intended for rapidly changing flows which could lead to instability.

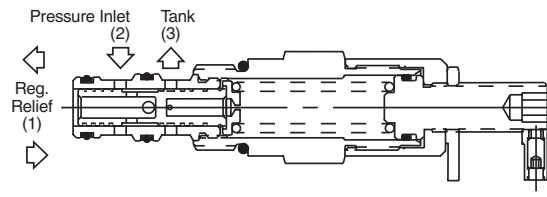

Pilot Operated Sequence Valves

Sequence valves are used to control the sequence of operation of two or more hydraulic actuators. The sequence valve pressure is set higher than the first actuator operation pressure. Once the first actuator has completed its cycle, the sequence valve opens allowing the second actuator to move. Parker's line of pilot operated sequence valves include a series of internally piloted, externally drained valves and a series of externally piloted, internally vented valves. Parker also offers a line of direct acting sequence valves which are ideal for piloting logic elements in steady state applications.

P.O. Sequence (Internally Piloted, Externally Drained)

OPERATION - For this valve, the pilot pressure is sensed from the inlet of the valve (port 1). When the pilot pressure exceeds the valve setting, the pilot section opens creating a pressure imbalance across the main spool. This causes the spool to move allowing the flow to pass from the nose of the cartridge (port 1) to the actuator port (port 2). By externally draining the pilot flow directly to tank (port 3), the valve is insensitive to back pressure at the sequence port.

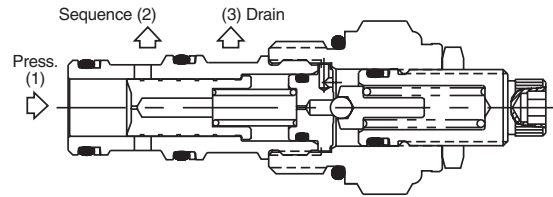

P.O. Sequence (Externally Piloted, Internally Vented)

OPERATION - For this valve, the pilot pressure is obtained from an external source and not from the pressure port. When the external pilot pressure (port 1) exceeds the valve setting, the pilot section opens creating a pressure imbalance across the main spool. This causes the spool to move allowing the flow to pass from the side of the cartridge (port 2) to the actuator port (port 3). Any pressure at port 3 is additive to the pressure setting. It is most common for port 3 to be connected to tank.

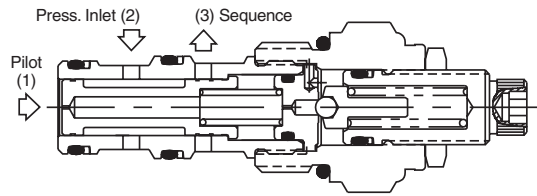

D.A. Sequence (Internally Piloted, Externally Drained)

OPERATION - In the steady state condition, all three ports are blocked with the spring chamber drained to port 3. When the pressure at port 1 exceeds the valve setting, the spool moves allowing flow from the nose of the cartridge (port 1) to the actuator port (port 2). By externally draining the spring chamber directly to tank (port 3), the valve is insensitive to back pressure at the sequence port.

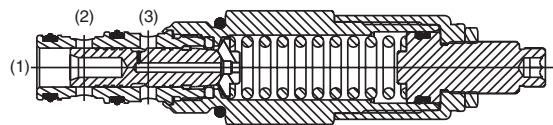
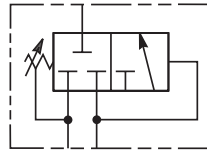

D.A. Sequence, N.O. (Externally Piloted, Externally Drained)

OPERATION - With no pressure at the pilot port (port 1), bi-directional flow is allowed between port 3 and port 2. When the pilot pressure at port 1 exceeds the valve setting the spool moves blocking both port 3 and port 2. By externally draining the spring chamber to tank (port 4), the valve is insensitive to back pressure at the sequencing ports.

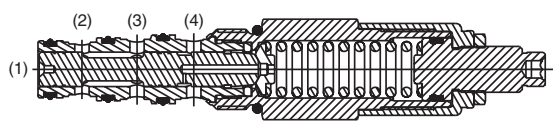
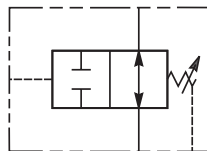

D.A. Sequence, N.C. (Externally Piloted)

OPERATION - With no pressure at the pilot port (port 1), both port 3 and port 2 are blocked. When the pilot pressure at port 1 exceeds the valve setting, the spool moves opening a path and allowing flow from port 3 to port 2. This valve internally drains the spring chamber to tank via the sequencing port, thus any backpressure on port 2 would be additive to the spring setting.

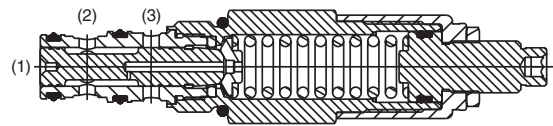
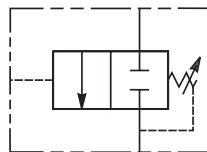

CV
Check Valves
SH
Shuttle Valves
LM
Load/Motor Controls
FC
Flow Controls
PC
Pressure Controls
LE
Logic Elements
DC
Directional Controls
MV
Manual Valves
SV
Solenoid Valves
PV
Proportional Valves
CE
Coils & Electronics
BC
Bodies & Cavities
TD
Technical Data

Technical Information

- CV** Check Valves
- SH** Shuttle Valves
- LM** Load/Motor Controls
- FC** Flow Controls
- PC** Pressure Controls
- LE** Logic Elements
- DC** Directional Controls
- MV** Manual Valves
- SV** Solenoid Valves
- PV** Proportional Valves
- CE** Coils & Electronics
- BC** Bodies & Cavities
- TD** Technical Data

General Description

Direct Acting Ball-Type Relief Valve. For additional information see Technical Tips on pages PC1-PC6.

Features

- Hardened, precision ground parts for durability
- Compact size for reduced space requirements
- Low leakage design
- Fast response
- All external parts zinc plated

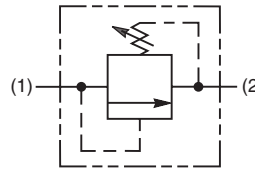
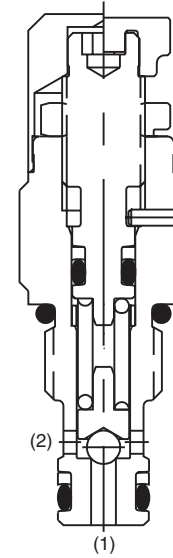

Specifications

Rated Flow	3.8 LPM (1 GPM)
Maximum Inlet Pressure	380 Bar (5500 PSI)
Maximum Pressure Setting	350 Bar (5000 PSI)
Maximum Tank Pressure	350 Bar (5000 PSI)
Reseat Pressure	80% of crack pressure
Leakage at 150 SSU (32 cSt)	10 drops/min. (.66 cc/min.) @75% of crack pressure
Cartridge Material	All parts steel. All operating parts hardened steel.
Operating Temp. Range/Seals	-40°C to +93.3°C (Nitrile) (-40°F to +200°F) -31.7°C to +121.1°C (Fluorocarbon) (-25°F to +250°F)
Fluid Compatibility/Viscosity	Mineral-based or synthetic with lubricating properties at viscosities of 45 to 2000 SSU (6 to 420 cSt)
Filtration	ISO Code 16/13, SAE Class 4 or better
Approx. Weight	.03 kg (.07 lbs.)
Cavity	C04-2 (See BC Section for more details)
Form Tool	Rougher None Finisher NFT04-2F

Performance Curve

Flow vs. Inlet Pressure

(Pressure rise through cartridge only)

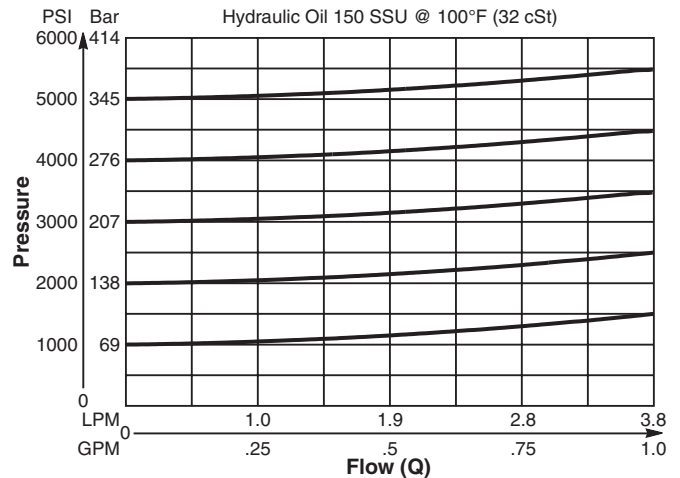

Dimensions Millimeters (Inches)

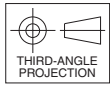
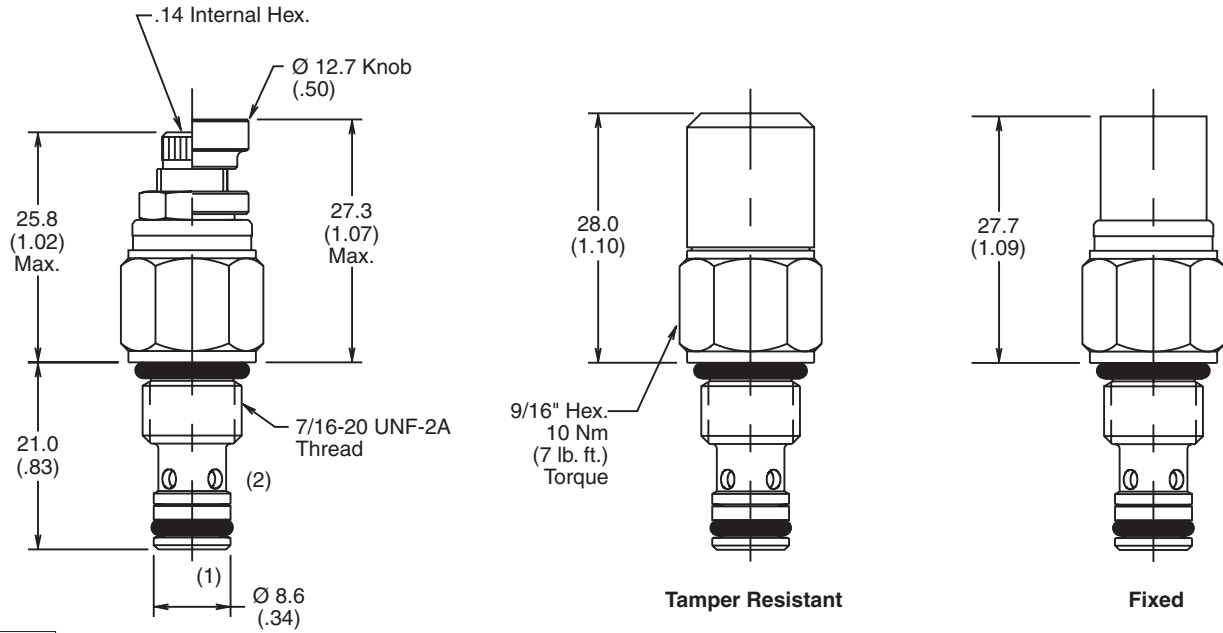

Ordering Information

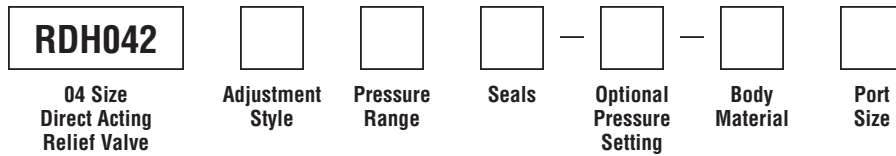

Code	Adjustment Style / Kit No.
F	Fixed style, preset at factory.
K	Knob Adjust (852544)
S	Screw Adjust
T	Tamper Resistant Cap (852519)

Code	Pressure Range
30	6.9 - 207 Bar (100 - 3000 PSI) Standard Setting: 103 Bar (1500 PSI) @ 1.9 LPM (.5 GPM)
50	103 - 345 Bar (1500 - 5000 PSI) Standard Setting: 172 Bar (2500 PSI) @ 1.9 LPM (.5 GPM)

Code	Seals / Kit No.
Omit	Nitrile / (SK04-2)
V	Fluorocarbon / (SK04-2V)

Optional Pressure Setting
Pressure \pm 10 i.e. 235 = 2350 PSI (Omit if standard setting is used) Setting Range: 100 to 5000 PSI All settings at 1.9 LPM (.5 GPM)

Code	Body Material
Omit	Steel
A	Aluminum

Code	Port Size	Body Part No.
Omit	Cartridge Only	
4T	SAE-4	(B04-2-*4T)

* Add "A" for aluminum, omit for steel.

Technical Information

- CV** Check Valves
- SH** Shuttle Valves
- LM** Load/Motor Controls
- FC** Flow Controls
- PC** Pressure Controls
- LE** Logic Elements
- DC** Directional Controls
- MV** Manual Valves
- SV** Solenoid Valves
- PV** Proportional Valves
- CE** Coils & Electronics
- BC** Bodies & Cavities
- TD** Technical Data

General Description

Direct Acting Relief Valve. This valve is designed for pilot flow circuits. For additional information see Technical Tips on pages PC1-PC6.



Features

- Hardened, precision ground parts for durability
- Low profile adapter for minimal space requirements
- Fully guided pilot for more consistent reseal
- Steel adapters are coated with yellow zinc dichromate for protection from salt spray
- Polyurethane "D"-Ring eliminates backup rings and prevents hydrolysis

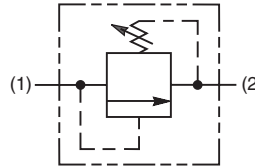
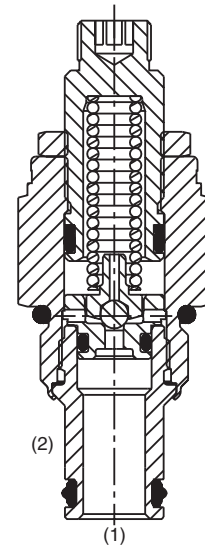
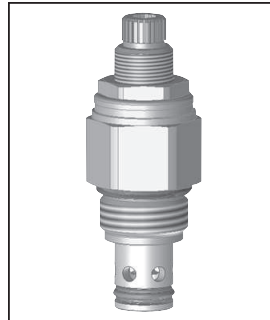

Specifications

Rated Flow	1.9 LPM (.5 GPM)
Maximum Inlet Pressure	380 Bar (5500 PSI)
Maximum Pressure Setting	350 Bar (5000 PSI)
Reseat Pressure	90% of crack pressure
Leakage at 150 SSU (32 cSt)	5 drops/min. (.33 cc/min.) @75% of crack pressure
Cartridge Material	All parts steel. All operating parts hardened steel.
Operating Temp. Range/Seals	-45°C to +93.3°C ("D"-Ring) (-50°F to +200°F) -31.7°C to +121.1°C (Fluorocarbon) (-25°F to +250°F)
Fluid Compatibility/ Viscosity	Mineral-based or synthetic with lubricating properties at viscosities of 45 to 2000 SSU (6 to 420 cSt)
Filtration	ISO Code 16/13, SAE Class 4 or better
Approx. Weight	.09 kg (.20 lbs.)
Cavity	C08-2 (See BC Section for more details)
Form Tool	Rougher None Finisher NFT08-2F

Performance Curve

Flow vs. Inlet Pressure

(Pressure rise through cartridge only)

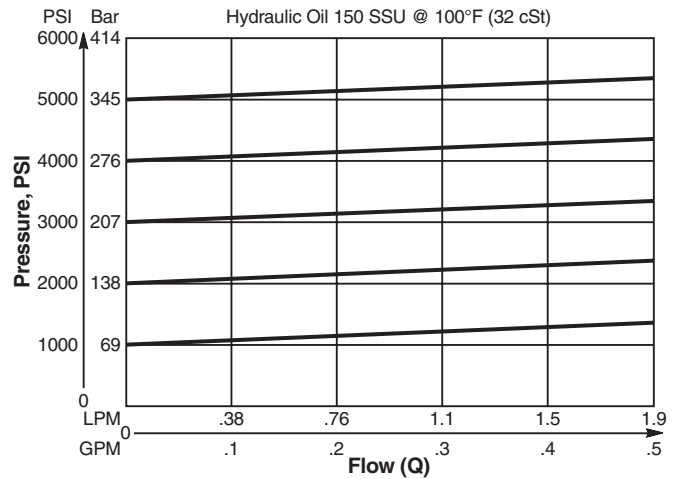

Dimensions Millimeters (Inches)

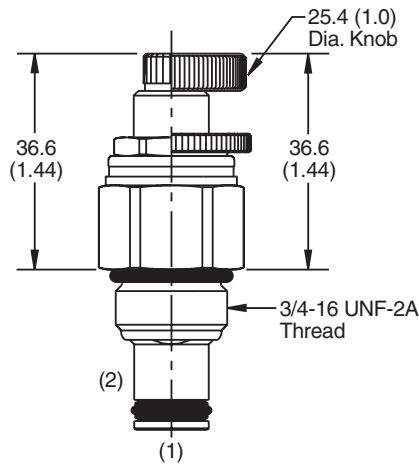

Screw/Knob Version

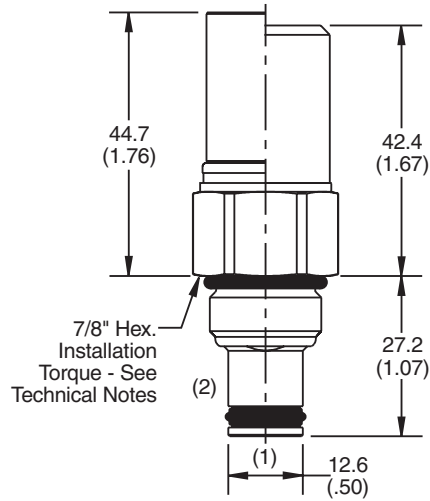

Fixed Cap/Tamper Resistant Version

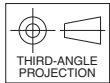

Ordering Information

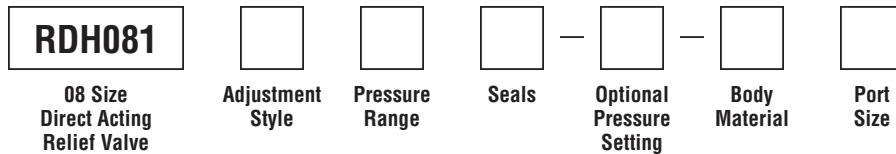

Code	Adjustment Style / Kit No.
F	Fixed style, preset at factory.
K	Knob Adjust (717784-10)
S	Screw Adjust
T	Tamper Resistant Cap (717943)

Code	Seals / Kit No.
Omit	"D"-Ring / (SK08-2)
N	Nitrile / (SK08-2N)
V	Fluorocarbon / (SK08-2V)

Code	Body Material
Omit	Steel
A	Aluminum

Code	Pressure Range
10	6.9 - 69 Bar (100 - 1000 PSI) Standard Setting: 34.5 Bar (500 PSI) @ crack pressure, approximately 100 cc/min (6.1 in ³ /min)
20	6.9 - 138 Bar (100 - 2000 PSI) Standard Setting: 69 Bar (1000 PSI) @ crack pressure, approximately 100 cc/min (6.1 in ³ /min)
30	13.8 - 207 Bar (200 - 3000 PSI) Standard Setting: 103.5 Bar (1500 PSI) @ crack pressure, approximately 100 cc/min (6.1 in ³ /min)
50	13.8 - 345 Bar (200 - 5000 PSI) Standard Setting: 172.4 Bar (2500 PSI) @ crack pressure, approximately 100 cc/min (6.1 in ³ /min)

Optional Pressure Setting
Pressure \pm 10 i.e. 235 = 2350 PSI (Omit if standard setting is used)
Setting Range: 100 to 5000 PSI All settings at crack pressure, approximately 100 cc/min (6.1 in ³ /min)

Code	Port Size	Body Part No.
Omit	Cartridge Only	
6P	3/8" NPTF	(B08-2-*6P)
4T	SAE-4	(B08-2-*4T)
6T	SAE-6	(B08-2-*6T)
6B	3/8" BSPG	(B08-2-*6B)

* Add "A" for aluminum, omit for steel.

Technical Information

- CV** Check Valves
- SH** Shuttle Valves
- LM** Load/Motor Controls
- FC** Flow Controls
- PC** Pressure Controls
- LE** Logic Elements
- DC** Directional Controls
- MV** Manual Valves
- SV** Solenoid Valves
- PV** Proportional Valves
- CE** Coils & Electronics
- BC** Bodies & Cavities
- TD** Technical Data

General Description

Direct Acting Poppet-Type Relief Valve. For additional information see Technical Tips on pages PC1-PC6.

Features

- Hardened, precision ground parts for durability
- Fast response
- Spherical poppets for low leakage
- Internal mechanical stop limits poppet travel eliminating spring solidification
- All external parts have yellow zinc dichromate. This coating is ideal for salt spray applications.
- Polyurethane "D"-Ring eliminates backup rings and prevents hydrolysis

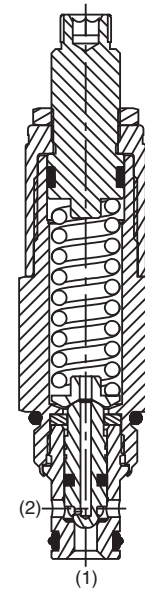
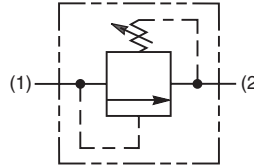
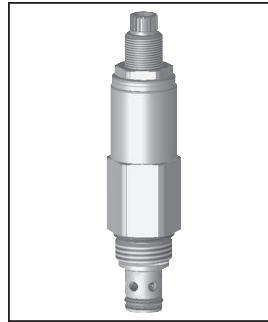

Specifications

Rated Flow	30 LPM (8 GPM)
Maximum Inlet Pressure	380 Bar (5500 PSI)
Maximum Pressure Setting	350 Bar (5000 PSI)
Reseat Pressure	85% of crack pressure
Leakage at 150 SSU (32 cSt)	5 drops/min. (.33 cc/min.) @75% of crack pressure
Cartridge Material	All parts steel. All operating parts hardened steel.
Operating Temp. Range/Seals	-45°C to +93.3°C ("D"-Ring) (-50°F to +200°F) -31.7°C to +121.1°C (Fluorocarbon) (-25°F to +250°F)
Fluid Compatibility/ Viscosity	Mineral-based or synthetic with lubricating properties at viscosities of 45 to 2000 SSU (6 to 420 cSt)
Filtration	ISO Code 16/13, SAE Class 4 or better
Approx. Weight	.18 kg (.40 lbs.)
Cavity	C08-2 (See BC Section for more details)
Form Tool	Rougher None Finisher NFT08-2F

Performance Curve

Flow vs. Inlet Pressure

(Pressure rise through cartridge only)

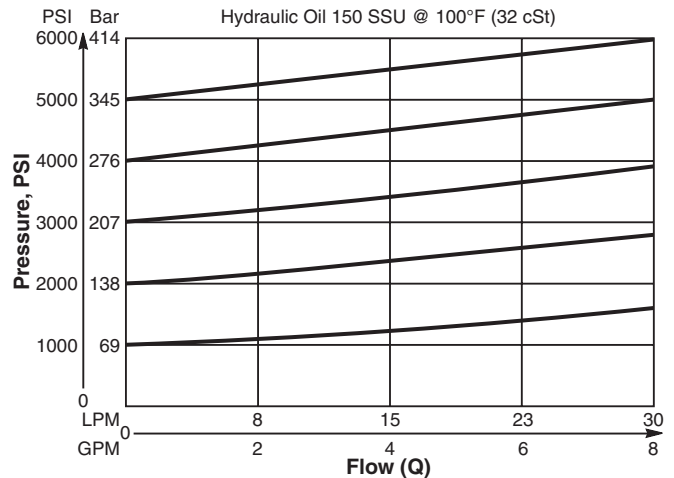

Dimensions Millimeters (Inches)

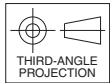
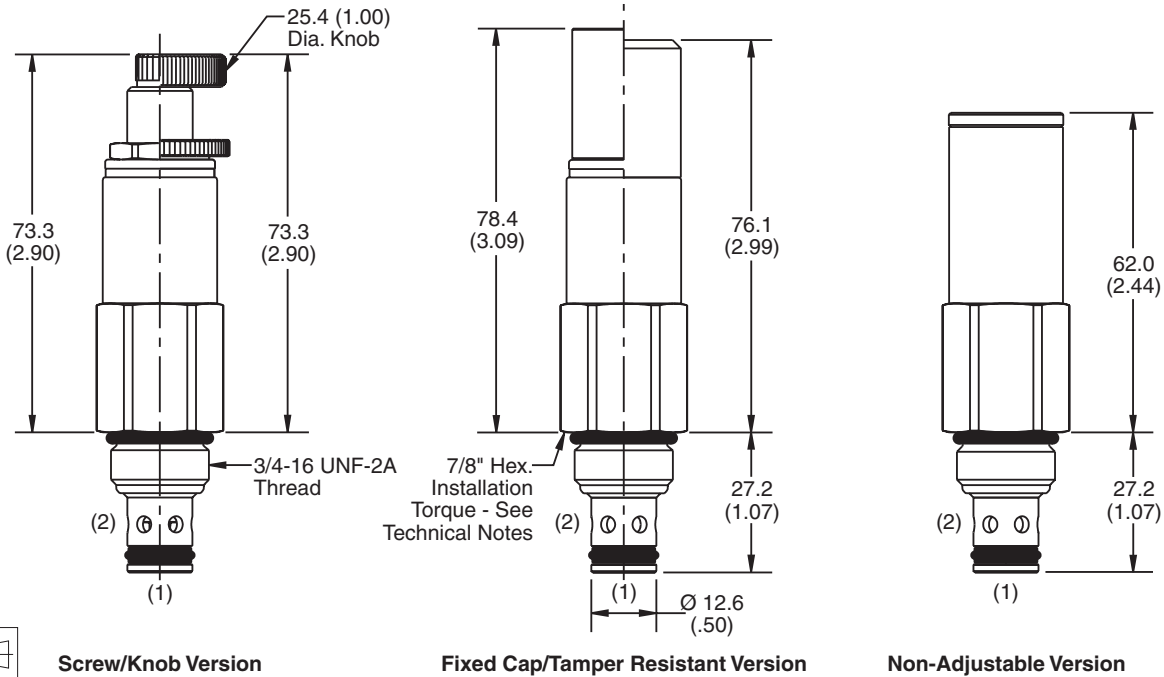

Screw/Knob Version

Fixed Cap/Tamper Resistant Version

Non-Adjustable Version

Ordering Information

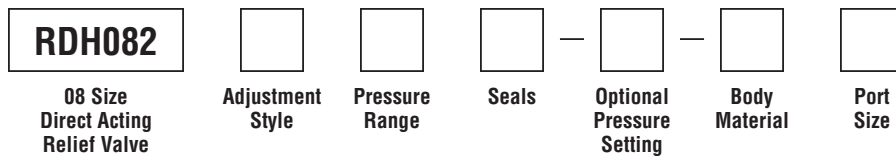

Code	Adjustment Style / Kit No.
F	Fixed style, preset at factory.
K	Knob Adjust (717784-10)
N	Non-Adjustable
S	Screw Adjust
T	Tamper Resistant Cap (717943)

Code	Seals / Kit No.
Omit	"D"-Ring / (SK08-2)
N	Nitrile / (SK08-2N)
V	Fluorocarbon / (SK08-2V)

Code	Body Material
Omit	Steel
A	Aluminum

Code	Pressure Range
15	6.9 - 103 Bar (100 - 1500 PSI) Standard Setting: 51.7 Bar (750 PSI) @ crack pressure approximately .95 LPM (.25 GPM)
30	17.2 - 207 Bar (250 - 3000 PSI) Standard Setting: 103 Bar (1500 PSI) @ crack pressure approximately .95 LPM (.25 GPM)
50	34.5 - 345 Bar (500 - 5000 PSI) Standard Setting: 172.4 Bar (2500 PSI) @ crack pressure approximately .95 LPM (.25 GPM)

Optional Pressure Setting
Pressure \pm 10 i.e. 235 = 2350 PSI (Omit if standard setting is used) Setting Range: 100 to 5000 PSI All settings at crack pressure, approximately .95 LPM (.25 GPM)

Code	Port Size	Body Part No.
Omit	Cartridge Only	
6P	3/8" NPTF	(B08-2-*6P)
4T	SAE-4	(B08-2-*4T)
6T	SAE-6	(B08-2-*6T)
4B	1/4" BSPG	(B08-2-*4B)
6B	3/8" BSPG	(B08-2-*6B)

* Add "A" for aluminum, omit for steel.

- CV Check Valves
- SH Shuttle Valves
- LM Load/Motor Controls
- FC Flow Controls
- PC Pressure Controls
- LE Logic Elements
- DC Directional Controls
- MV Manual Valves
- SV Solenoid Valves
- PV Proportional Valves
- CE Coils & Electronics
- BC Bodies & Cavities
- TD Technical Data

Technical Information

- CV** Check Valves
- SH** Shuttle Valves
- LM** Load/Motor Controls
- FC** Flow Controls
- PC** Pressure Controls
- LE** Logic Elements
- DC** Directional Controls
- MV** Manual Valves
- SV** Solenoid Valves
- PV** Proportional Valves
- CE** Coils & Electronics
- BC** Bodies & Cavities
- TD** Technical Data

General Description

Direct Acting Relief Valve. This valve is designed for pilot flow circuits. For additional information see Technical Tips on pages PC1-PC6.



Features

- Hardened, precision ground parts for durability
- Low profile adapter for minimal space requirements
- Fully guided poppet for more consistent reseal
- Steel adapters are coated with yellow zinc dichromate for protection from salt spray
- Polyurethane "D"-Ring eliminates backup rings and prevents hydrolysis

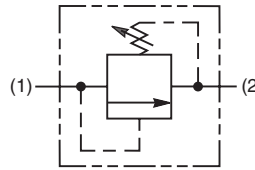
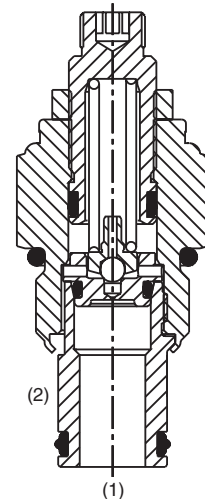

Specifications

Rated Flow	1.9 LPM (.5 GPM)
Maximum Inlet Pressure	380 Bar (5500 PSI)
Maximum Pressure Setting	350 Bar (5000 PSI)
Reseat Pressure	90% of crack pressure
Leakage at 150 SSU (32 cSt)	5 drops/min. (.33 cc/min.) @ 80% of crack pressure
Cartridge Material	All parts steel. All operating parts hardened steel.
Operating Temp. Range/Seals	-45°C to +93.3°C ("D"-Ring) (-50°F to +200°F) -31.7°C to +121.1°C (Fluorocarbon) (-25°F to +250°F)
Fluid Compatibility/ Viscosity	Mineral-based or synthetic with lubricating properties at viscosities of 45 to 2000 SSU (6 to 420 cSt)
Filtration	ISO Code 16/13, SAE Class 4 or better
Approx. Weight	.18 kg (.40 lbs.)
Cavity	C10-2
Form Tool	Rougher None Finisher NFT10-2F

Performance Curve

Flow vs. Inlet Pressure

(Pressure rise through cartridge only)

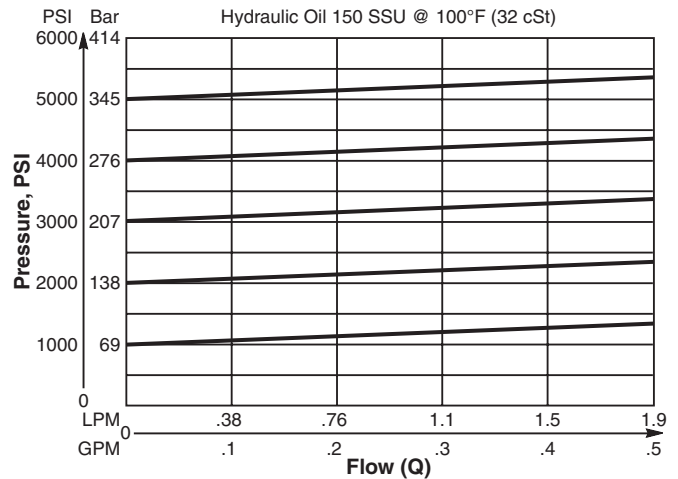

Dimensions Millimeters (Inches)

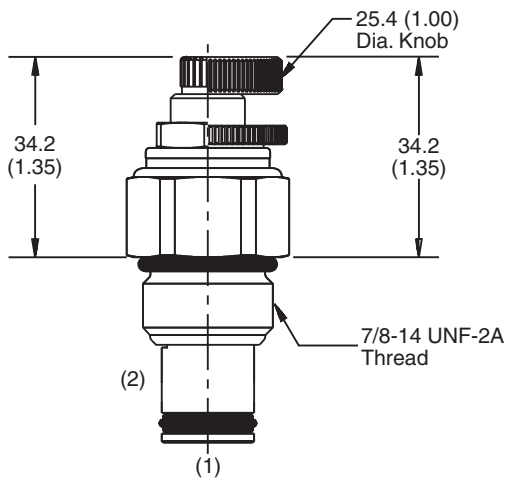

Screw/Knob Version

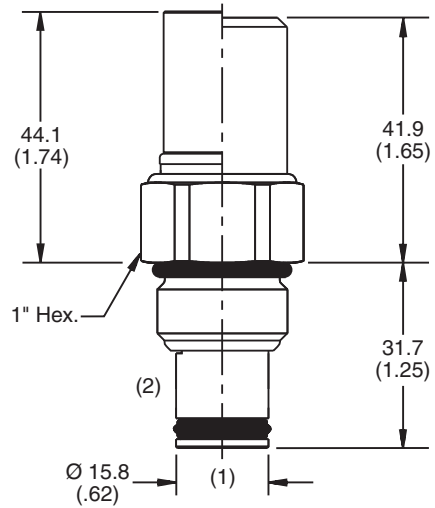

Fixed Cap/Tamper Resistant Version

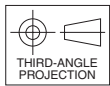

Ordering Information

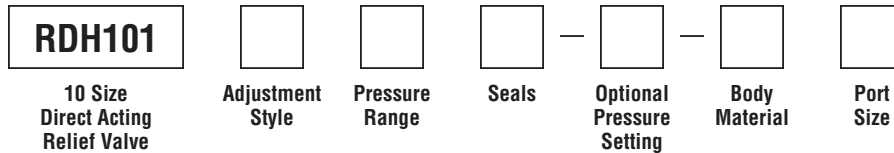

Code	Adjustment Style / Kit No.
F	Fixed style, preset at factory.
K	Knob Adjust (717784-10)
S	Screw Adjust
T	Tamper Resistant Cap (718083)

Code	Seals / Kit No.
Omit	"D"-Ring / (SK10-2)
N	Nitrile / (SK10-2N)
V	Fluorocarbon / (SK10-2V)

Code	Body Material
Omit	Steel
A	Aluminum

Code	Pressure Range
10	6.9 - 69 Bar (100 - 1000 PSI) Standard Setting: 34.5 Bar (500 PSI) @ crack pressure, approximately 100 cc/min (6.1 in ³ /min)
20	6.9 - 138 Bar (100 - 2000 PSI) Standard Setting: 69 Bar (1000 PSI) @ crack pressure, approximately 100 cc/min (6.1 in ³ /min)
30	13.8 - 207 Bar (200 - 3000 PSI) Standard Setting: 103.5 Bar (1500 PSI) @ crack pressure, approximately 100 cc/min (6.1 in ³ /min)
50	13.8 - 345 Bar (200 - 5000 PSI) Standard Setting: 172.4 Bar (2500 PSI) @ crack pressure, approximately 100 cc/min (6.1 in ³ /min)

Optional Pressure Setting
Pressure ÷ 10 i.e. 235 = 2350 PSI (Omit if standard setting is used)
Setting Range: 100 to 5000 PSI All settings at crack pressure, approximately 100 cc/min (6.1 in ³ /min)

Code	Port Size	Body Part No.
Omit	Cartridge Only	
4P	1/4" NPTF	(B10-2-*4P)
6P	3/8" NPTF	(B10-2-*6P)
8P	1/2" NPTF	(B10-2-*8P)
6T	SAE-6	(B10-2-*6T)
T6T	SAE-6	(B10-2-T6T)†
8T	SAE-8	(B10-2-*8T)
T8T	SAE-8	(B10-2-T8T)†
6B	3/8" BSPG	(B10-2-6B)†

* Add "A" for aluminum, omit for steel.
 † Steel body only.

Technical Information

- CV** Check Valves
- SH** Shuttle Valves
- LM** Load/Motor Controls
- FC** Flow Controls
- PC** Pressure Controls
- LE** Logic Elements
- DC** Directional Controls
- MV** Manual Valves
- SV** Solenoid Valves
- PV** Proportional Valves
- CE** Coils & Electronics
- BC** Bodies & Cavities
- TD** Technical Data

General Description

Direct Acting Ball-Type Relief Valve. For additional information see Technical Tips on pages PC1-PC6.

Features

- Fast response
- Ideal for controlling ventable relief valves, or for thermal relief
- Hardened working parts for maximum durability
- Integral 250 micron inlet filter available
- All external parts zinc plated

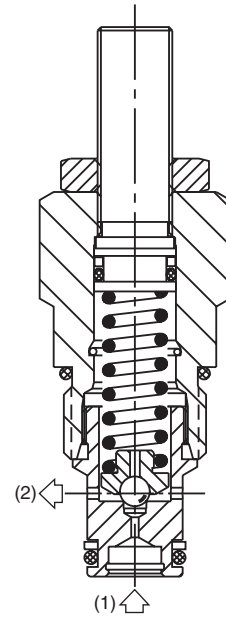
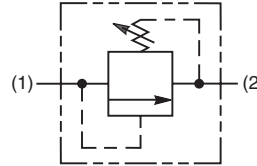
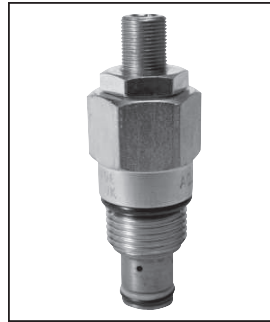

Specifications

Rated Flow	6 LPM (1.6 GPM)
Maximum Inlet Pressure	H - 10-210 Bar (145-3000 PSI) P - 10-420 Bar (145-6000 PSI)
Maximum Pressure Setting	420 Bar (6000 PSI)
Maximum Tank Pressure	420 Bar (6000 PSI)
Leakage at 150 SSU (32 cSt)	5 drops/min. @ 100 Bar (1450 PSI)
Cartridge Material	All parts steel. All operating parts hardened steel.
Operating Temp. Range/Seals	-40°C to +93.3°C (Nitrile) (-40°F to +200°F) -31.7°C to +121.1°C (Fluorocarbon) (-25°F to +250°F)
Fluid Compatibility/Viscosity	Mineral-based or synthetic with lubricating properties at viscosities of 45 to 2000 SSU (6 to 420 cSt)
Filtration	ISO Code 16/13, SAE Class 4 or better
Approx. Weight	0.11 kg (0.24 lbs.)
Cavity	C08-2 (See BC Section for more details)
Form Tool	Rougher None Finisher NFT08-2F

Performance Curves

(Pressure rise through cartridge only)

Flow vs. Inlet Pressure

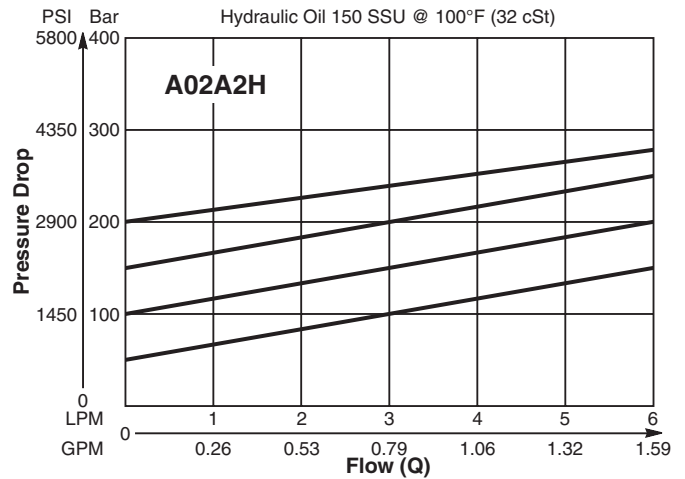

Flow vs. Inlet Pressure

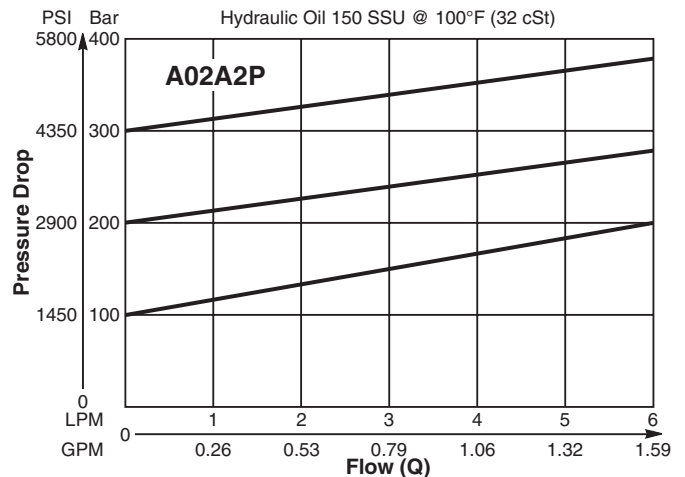

Dimensions Millimeters (Inches)

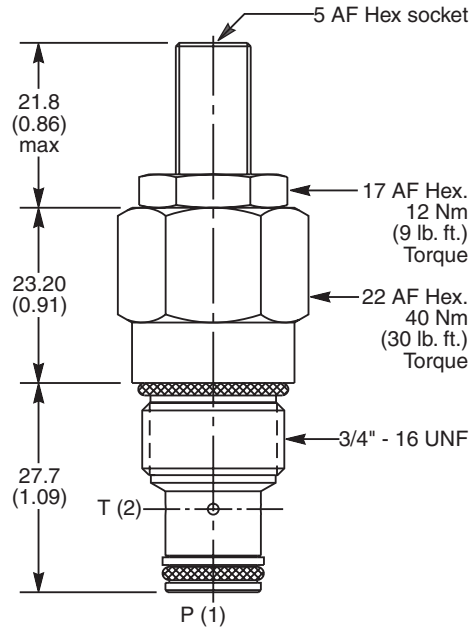

Ordering Information

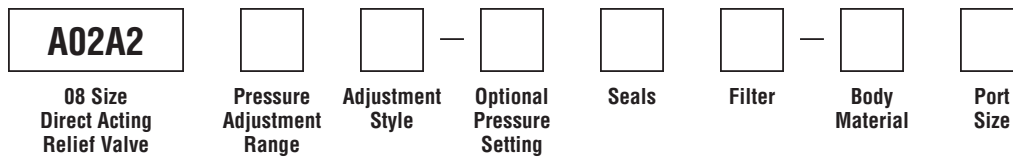

Code	Pressure Adjustment Range
H	10 - 210 Bar (145 - 3000 PSI)
P	10 - 420 Bar (145 - 6000 PSI)

Code	Seals / Kit No.
N	Nitrile, Buna-N (Std.) / (SK30515N-1)
V	Fluorocarbon / (SK30515V-1)

Code	Body Material
Omit	Steel
A	Aluminum

Code	Adjustment Style / Kit No.
Z	Screw Adjust (Std.)
W	Knob Adjust
T	Tamper Resistant Cap (TC1130)

Code	Filter
Omit	Omit for no filter (Std.)
F	250 micron inlet filter

Code	Port Size	Body Part No.
Omit	Cartridge Only	
4P	1/4" NPTF	(B08-2-*4P)
6P	3/8" NPTF	(B08-2-*6P)
4T	SAE-4	(B08-2-*4T)
6T	SAE-6	(B08-2-*6T)
6B	3/8" BSPG	(B08-2-*6B)

* Add "A" for aluminum, omit for steel.

Optional Pressure Setting	
Specify setting if required (Bar)	
A02A2H Standard Setting: 100 Bar (1400 PSI) @ 0.5 LPM (0.13 GPM)	
A02A2P Standard Setting: 200 Bar (2900 PSI) @ 0.5 LPM (0.13 GPM)	

- CV**
Check Valves
- SH**
Shuttle Valves
- LM**
Load/Motor Controls
- FC**
Flow Controls
- PC**
Pressure Controls
- LE**
Logic Elements
- DC**
Directional Controls
- MV**
Manual Valves
- SV**
Solenoid Valves
- PV**
Proportional Valves
- CE**
Coils & Electronics
- BC**
Bodies & Cavities
- TD**
Technical Data

Technical Information

- CV** Check Valves
- SH** Shuttle Valves
- LM** Load/Motor Controls
- FC** Flow Controls
- PC** Pressure Controls
- LE** Logic Elements
- DC** Directional Controls
- MV** Manual Valves
- SV** Solenoid Valves
- PV** Proportional Valves
- CE** Coils & Electronics
- BC** Bodies & Cavities
- TD** Technical Data

General Description

Direct Acting Poppet-Type Relief Valve. For additional information see Technical Tips on pages PC1-PC6.

Features

- Fast response
- Excellent stability throughout flow range
- Virtually leak free
- Hardened working parts for maximum durability
- Adjustable, preset and tamper resistant versions available
- Preset version is tamper resistant and compact
- All external parts zinc plated

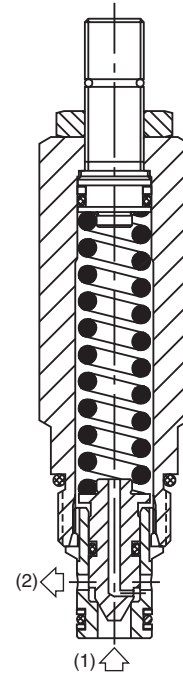
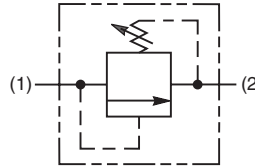
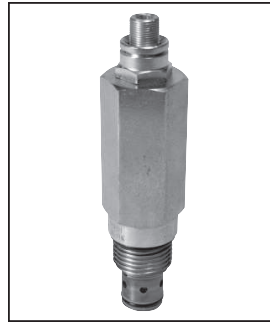

Specifications

Rated Flow	30 LPM (8 GPM)
Maximum Inlet Pressure	420 Bar (6000 PSI)
Maximum Pressure Setting	F - 2-100 Bar (29-1450 PSI) H - 5-210 Bar (72-3000 PSI) P - 5-420 Bar (72-6000 PSI)
Maximum Tank Pressure	420 Bar (6000 PSI)
Leakage at 150 SSU (32 cSt)	5 drops/min. @ 100 Bar (1450 PSI)
Cartridge Material	All parts steel. All operating parts hardened steel.
Operating Temp. Range/Seals	-40°C to +93.3°C (Nitrile) (-40°F to +200°F) -31.7°C to +121.1°C (Fluorocarbon) (-25°F to +250°F)
Fluid Compatibility/Viscosity	Mineral-based or synthetic with lubricating properties at viscosities of 45 to 2000 SSU (6 to 420 cSt)
Filtration	ISO Code 16/13, SAE Class 4 or better
Approx. Weight	0.20 kg (0.44 lbs.)
Cavity	C08-2 (See BC Section for more details)
Form Tool	Rougher None Finisher NFT08-2F

Performance Curves

(Pressure rise through cartridge only)

Flow vs. Inlet Pressure

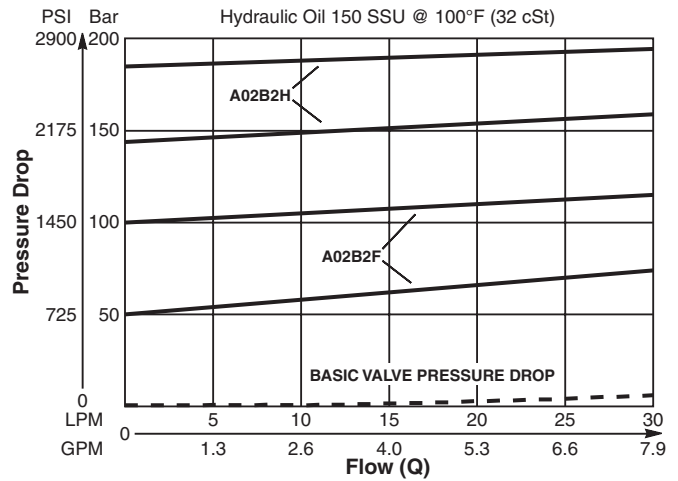

Flow vs. Inlet Pressure

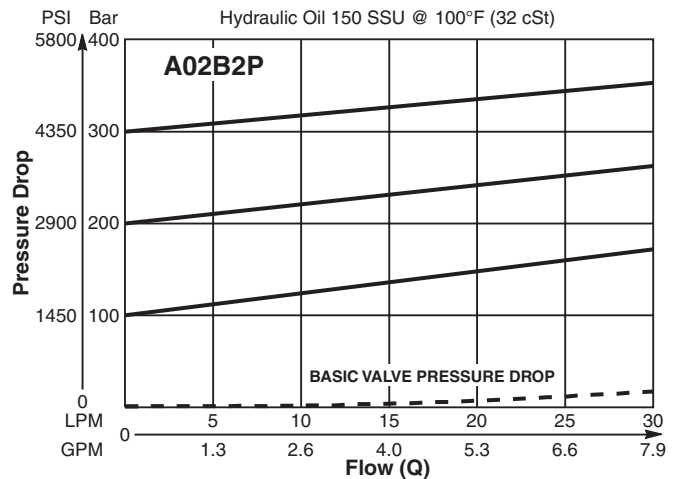

Dimensions Millimeters (Inches)

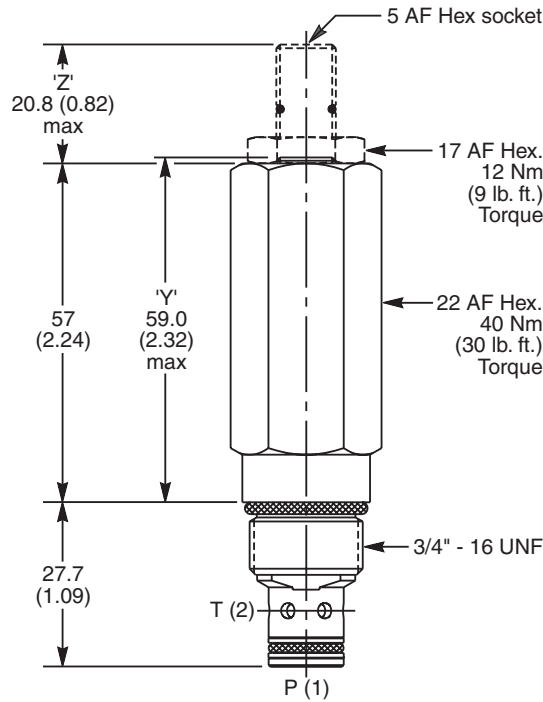

Ordering Information

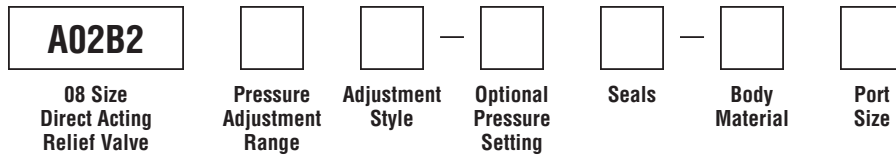

Code	Pressure Adjustment Range
F	2 - 100 Bar (29 - 1450 PSI)
H	5 - 210 Bar (72 - 3000 PSI)
P	5 - 420 Bar (72 - 6000 PSI)

Code	Adjustment Style / Kit No.
Z	Screw Adjust (Std.)
W	Knob Adjust
T	Tamper Resistant Cap (TC1130)
Y	Non Adjustable Preset

Optional Pressure Setting
Specify setting if required (Bar) Y Setting must be specified
A02B2F Standard Setting: 50 Bar (725 PSI) @ 2 LPM (0.5 GPM)
A02B2H Standard Setting: 100 Bar (1450 PSI) @ 2 LPM (0.5 GPM)
A02B2P Standard Setting: 200 Bar (2900 PSI) @ 2 LPM (0.5 GPM)

Code	Body Material
Omit	Steel
A	Aluminum

Code	Port Size	Body Part No.
Omit	Cartridge Only	
4P	1/4" NPTF	(B08-2-*4P)
6P	3/8" NPTF	(B08-2-*6P)
4T	SAE-4	(B08-2-*4T)
6T	SAE-6	(B08-2-*6T)
6B	3/8" BSPG	(B08-2-*6B)

* Add "A" for aluminum, omit for steel.

Code	Seals / Kit No.
N	Nitrile, Buna-N (Std.) / (SK30500N-1)
V	Fluorocarbon / (SK30500V-1)

- CV** Check Valves
- SH** Shuttle Valves
- LM** Load/Motor Controls
- FC** Flow Controls
- PC** Pressure Controls
- LE** Logic Elements
- DC** Directional Controls
- MV** Manual Valves
- SV** Solenoid Valves
- PV** Proportional Valves
- CE** Coils & Electronics
- BC** Bodies & Cavities
- TD** Technical Data

Technical Information

- CV** Check Valves
- SH** Shuttle Valves
- LM** Load/Motor Controls
- FC** Flow Controls
- PC** Pressure Controls
- LE** Logic Elements
- DC** Directional Controls
- MV** Manual Valves
- SV** Solenoid Valves
- PV** Proportional Valves
- CE** Coils & Electronics
- BC** Bodies & Cavities
- TD** Technical Data

General Description

Direct Acting Poppet-Type Relief Valve.
For additional information see
Technical Tips on pages PC1-PC6.



Features

- Hardened, precision ground parts for durability
- Internal mechanical stop limits poppet travel eliminating spring solidification
- Spherical poppets for low leakage
- “D”-Ring eliminates backup rings
- All external parts have yellow zinc dichromate. This coating is ideal for salt spray applications.
- Fast response

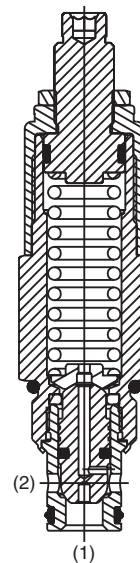
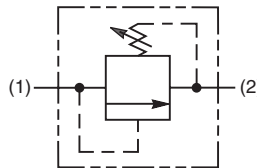

Specifications

Rated Flow	38 LPM (10 GPM)
Maximum Inlet Pressure	250 Bar (3600 PSI)
Maximum Pressure Setting	210 Bar (3000 PSI)
Maximum Tank Pressure	210 Bar (3000 PSI)
Reseat Pressure	85% of crack pressure
Leakage at 150 SSU (32 cSt)	5 drops/min. (.33 cc/min.) @75% of crack pressure
Cartridge Material	All parts steel. All operating parts hardened steel.
Operating Temp. Range (Ambient)	-45°C to +93.3°C (“D”-Ring) (-50°F to +200°F) -31.7°C to +121.1°C (Fluorocarbon) (-25°F to +250°F)
Fluids	Mineral-based or synthetic with lubricating properties at viscosities of 45 to 2000 SSU (6 to 420 cSt)
Filtration	ISO Code 16/13, SAE Class 4 or better
Approx. Weight	.23 kg (0.5 lbs.)
Cavity	C10-2 (See BC Section for more details)
Form Tool	Rougher None Finisher NFT10-2F

Performance Curve

Flow vs. Inlet Pressure

(Pressure rise through cartridge only)

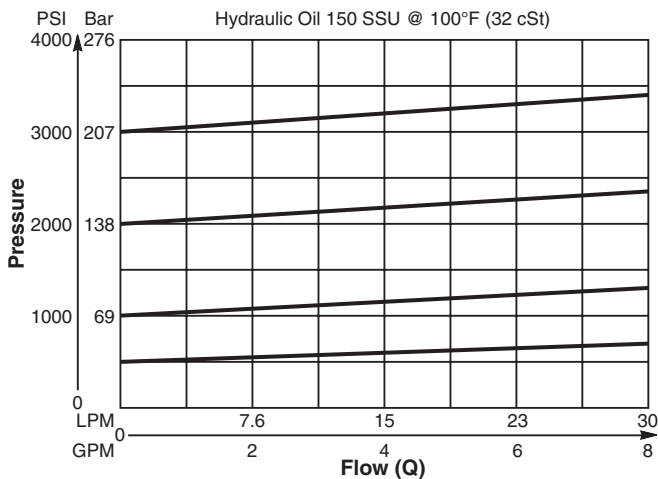

Dimensions Millimeters (Inches)

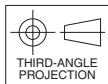
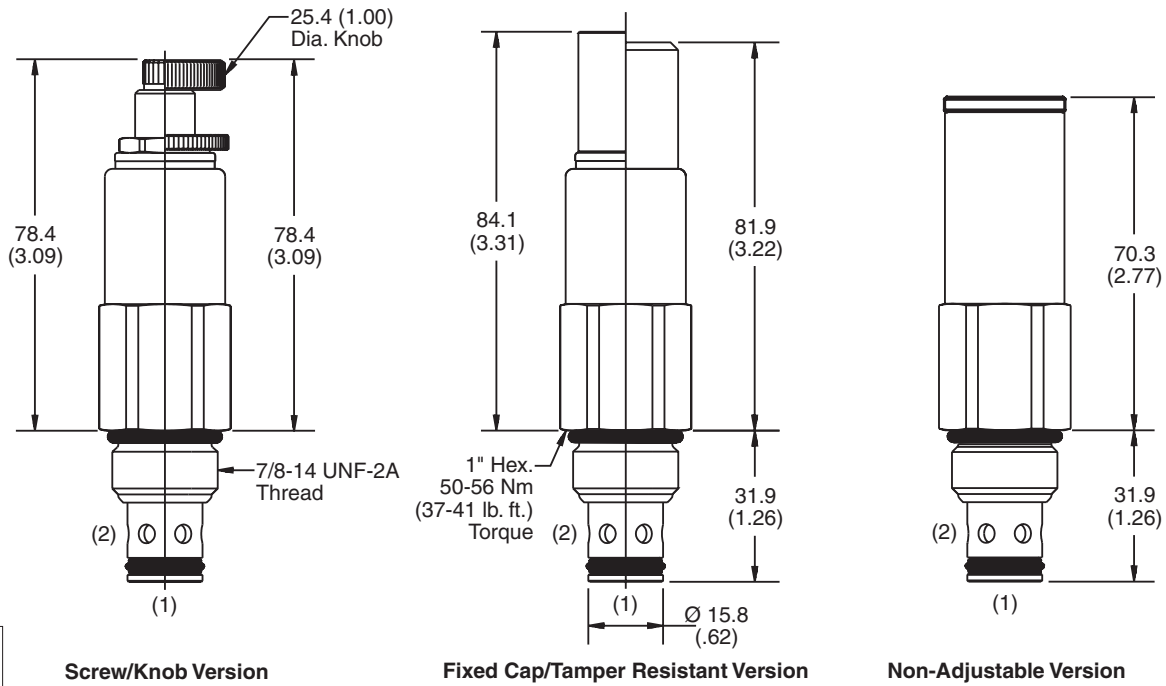

- CV**
Check Valves
- SH**
Shuttle Valves
- LM**
Load/Motor Controls
- FC**
Flow Controls
- PC**
Pressure Controls
- LE**
Logic Elements
- DC**
Directional Controls
- MV**
Manual Valves
- SV**
Solenoid Valves
- PV**
Proportional Valves
- CE**
Coils & Electronics
- BC**
Bodies & Cavities
- TD**
Technical Data

Ordering Information

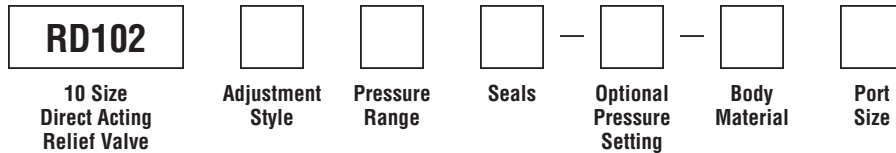

Code	Adjustment Style / Kit No.
F	Fixed style, preset at factory.
K	Knob Adjust (717784-10)
N	Non-Adjustable
S	Screw Adjust
T	Tamper Resistant Cap (717943)

Code	Seals / Kit No.
Omit	"D"-Ring / (SK10-2)
N	Nitrile / (SK10-2N)
V	Fluorocarbon / (SK10-2V)

Code	Body Material
Omit	Steel
A	Aluminum

Code	Pressure Range
03	3.5 - 20.7 Bar (50 - 300 PSI) Standard Setting: 10.3 Bar (150 PSI) @ .95 LPM (.25 GPM)
09	7 - 62 Bar (100 - 900 PSI) Standard Setting: 31.0 Bar (450 PSI) @ .95 LPM (.25 GPM)
18	13.8 - 124 Bar (200 - 1800 PSI) Standard Setting: 62.1 Bar (900 PSI) @ .95 LPM (.25 GPM)
30	41.4 - 207 Bar (600 - 3000 PSI) Standard Setting: 103.4 Bar (1500 PSI) @ .95 LPM (.25 GPM)

Optional Pressure Setting
Pressure \pm 10 i.e. 235 = 2350 PSI (Omit if standard setting is used) Setting Range: 100 to 3000 PSI All settings at .95 LPM (.25 GPM)

Code	Port Size	Body Part No.
Omit	Cartridge Only	
4P	1/4" NPTF	(B10-2-*4P)
6P	3/8" NPTF	(B10-2-*6P)
8P	1/2" NPTF	(B10-2-*8P)
6T	SAE-6	(B10-2-*6T)
8T	SAE-8	(B10-2-*8T)
T8T	SAE-8	(B10-2-T8T)†
6B	3/8" BSPG	(B10-2-6B)†

* Add "A" for aluminum, omit for steel.
 † Steel body only.

Technical Information

- CV** Check Valves
- SH** Shuttle Valves
- LM** Load/Motor Controls
- FC** Flow Controls
- PC** Pressure Controls
- LE** Logic Elements
- DC** Directional Controls
- MV** Manual Valves
- SV** Solenoid Valves
- PV** Proportional Valves
- CE** Coils & Electronics
- BC** Bodies & Cavities
- TD** Technical Data

General Description

Direct Acting Poppet-Type Relief Valve. For additional information see Technical Tips on pages PC1-PC6.

Features

- Fast response with good stability
- Virtually leak-free
- Hardened working parts for maximum durability
- Adjustable, preset and tamperproof versions available
- Preset version is tamperproof and compact
- All external parts zinc plated

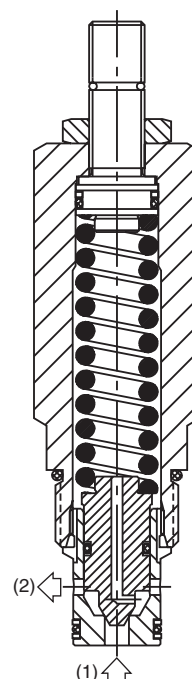
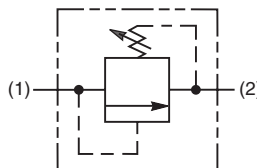
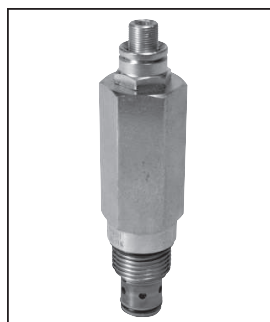

Specifications

Rated Flow	100 LPM (26 GPM)
Maximum Inlet Pressure	H - 5-210 Bar (72-3000 PSI) P - 5-420 Bar (72-6000 PSI)
Maximum Pressure Setting	420 Bar (6000 PSI)
Maximum Tank Pressure	420 Bar (6000 PSI)
Leakage at 150 SSU (32 cSt)	5 drops/min. @ 100 Bar (1450 PSI)
Cartridge Material	All parts steel. All operating parts hardened steel.
Operating Temp. Range/Seals	-40°C to +93.3°C (Nitrile) (-40°F to +200°F) -31.7°C to +121.1°C (Fluorocarbon) (-25°F to +250°F)
Fluid Compatibility/Viscosity	Mineral-based or synthetic with lubricating properties at viscosities of 45 to 2000 SSU (6 to 420 cSt)
Filtration	ISO Code 16/13, SAE Class 4 or better
Approx. Weight	0.28 kg (0.62 lbs.)
Cavity	C10-2 (See BC Section for more details)
Form Tool	Rougher None Finisher NFT10-2F

Performance Curves

(Pressure rise through cartridge only)

Flow vs. Inlet Pressure

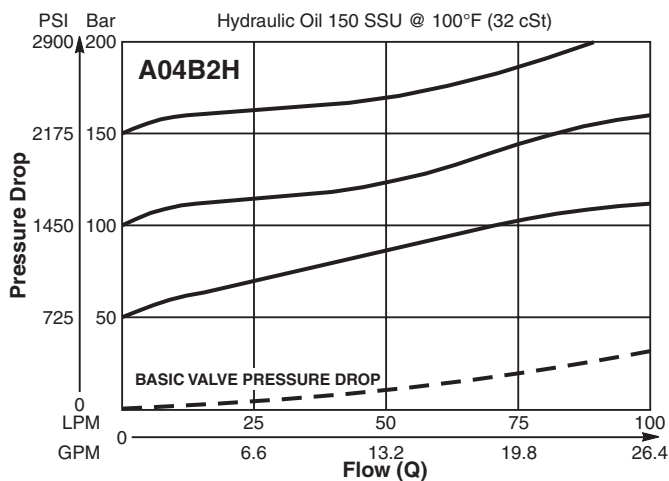

Flow vs. Inlet Pressure

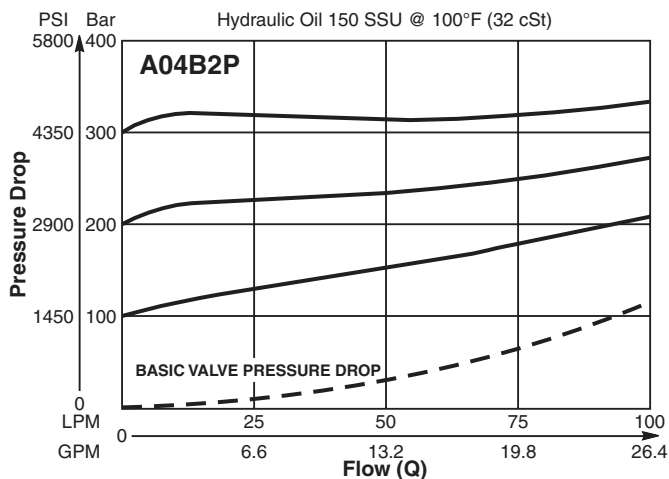

Dimensions Millimeters (Inches)

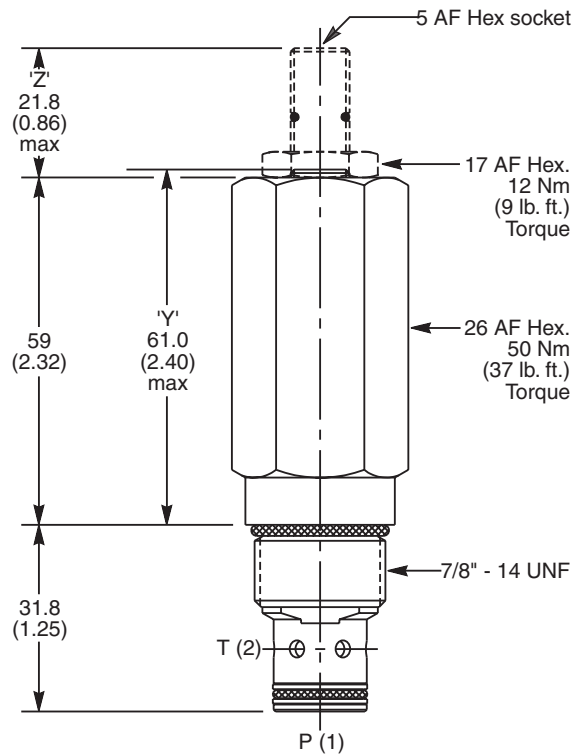

Ordering Information

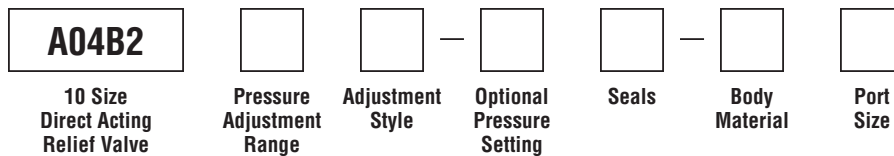

Code	Pressure Adjustment Range
H	5 - 210 Bar (72 - 3000 PSI)
P	5 - 420 Bar (72 - 6000 PSI)

Code	Seals / Kit No.
N	Nitrile, Buna-N (Std.) / (SK30503N-1)
V	Fluorocarbon / (SK30503V-1)

Code	Body Material
Omit	Steel
A	Aluminum

Code	Adjustment Style / Kit No.
Z	Screw Adjust (Std.)
W	Knob Adjust
T	Tamper Resistant Cap (TC1130)
Y	Non Adjustable Preset

Code	Port Size	Body Part No.
Omit	Cartridge Only	
4P	1/4" NPTF	(B10-2-*4P)
6P	3/8" NPTF	(B10-2-*6P)
8P	1/2" NPTF	(B10-2-*8P)
6T	SAE-6	(B10-2-*6T)
8T	SAE-8	(B10-2-*8T)
T8T	SAE-8	(B10-2-T8T)†
6B	3/8" BSPG	(B10-2-6B)†

Optional Pressure Setting	
Specify setting if required (Bar)	
Y Setting must be specified	
A04B2H Standard Setting: 100 Bar (1450 PSI) @ 15 LPM (4.0 GPM)	
A04B2P Standard Setting: 200 Bar (2900 PSI) @ 15 LPM (4.0 GPM)	

* Add "A" for aluminum, omit for steel.
 † Steel body only.

- CV**
Check Valves
- SH**
Shuttle Valves
- LM**
Load/Motor Controls
- FC**
Flow Controls
- PC**
Pressure Controls
- LE**
Logic Elements
- DC**
Directional Controls
- MV**
Manual Valves
- SV**
Solenoid Valves
- PV**
Proportional Valves
- CE**
Coils & Electronics
- BC**
Bodies & Cavities
- TD**
Technical Data

Technical Information

- CV** Check Valves
- SH** Shuttle Valves
- LM** Load/Motor Controls
- FC** Flow Controls
- PC** Pressure Controls
- LE** Logic Elements
- DC** Directional Controls
- MV** Manual Valves
- SV** Solenoid Valves
- PV** Proportional Valves
- CE** Coils & Electronics
- BC** Bodies & Cavities
- TD** Technical Data

General Description

Direct Acting Poppet-Type Relief Valve. Pressure Equipment Directive (PED 97/23/EC) compliant to hazard category IV. For additional information see Technical Tips on pages PC1-PC6.

Features

- Fast response with good stability
- Compact space saving design
- Poppet type construction for lower leakage
- Full 420 Bar (6000 PSI) pressure capability
- Hardened working parts for maximum durability
- Tamperproof setting
- All external parts zinc plated

Specifications

Rated Flow	100 LPM (26 GPM)
Maximum Inlet Pressure	FY - 2-100 Bar (29-1450 PSI) HY - 5-210 Bar (72-3000 PSI) PY - 5-420 Bar (72-6000 PSI)
Maximum Pressure Setting	420 Bar (6000 PSI)
Sensitivity: Pressure/Turn	FY - 11 Bar (165 PSI) HY - 21 Bar (305 PSI) PY - 44 Bar (630 PSI)
Leakage at 150 SSU (32 cSt)	5 drops/min. @ 100 Bar (1450 PSI)
Cartridge Material	All parts steel. All operating parts hardened steel.
Operating Temp. Range/Seals	-40°C to +93.3°C (Nitrile) (-40°F to +200°F) -31.7°C to +121.1°C (Fluorocarbon) (-25°F to +250°F)
Fluid Compatibility/Viscosity	Mineral-based or synthetic with lubricating properties at viscosities of 45 to 2000 SSU (6 to 420 cSt)
Filtration	ISO Code 16/13, SAE Class 4 or better
Approx. Weight	0.25 kg (0.55 lbs.)
Cavity	C10-2 (See BC Section for more details)
Form Tool	Rougher None Finisher NFT10-2F

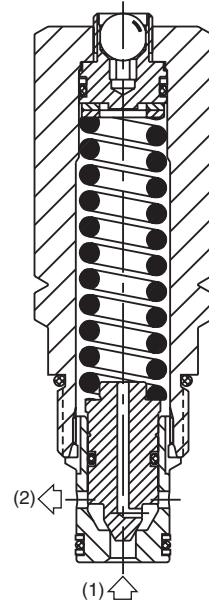
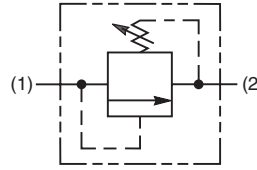

Performance Curves

(Pressure rise through cartridge only)

Flow vs. Inlet Pressure

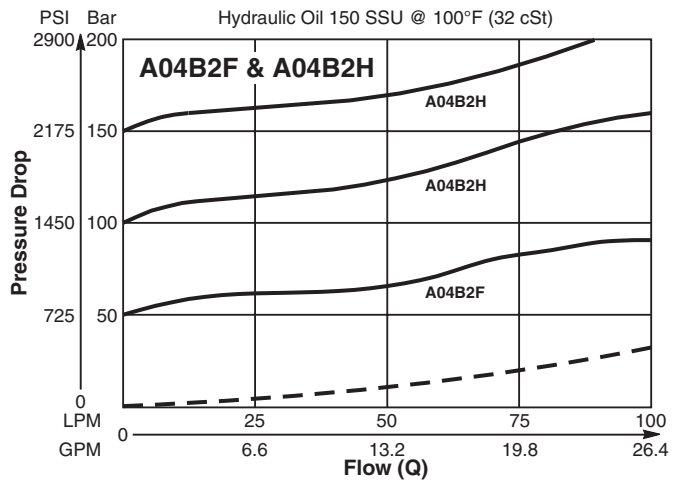

Flow vs. Inlet Pressure

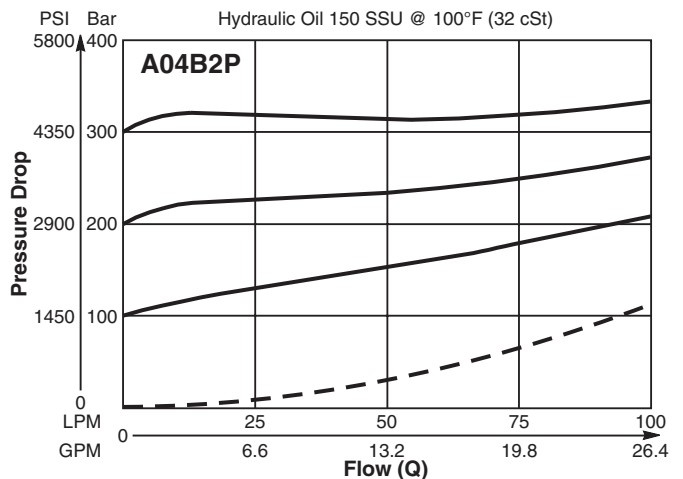

Dimensions Millimeters (Inches)

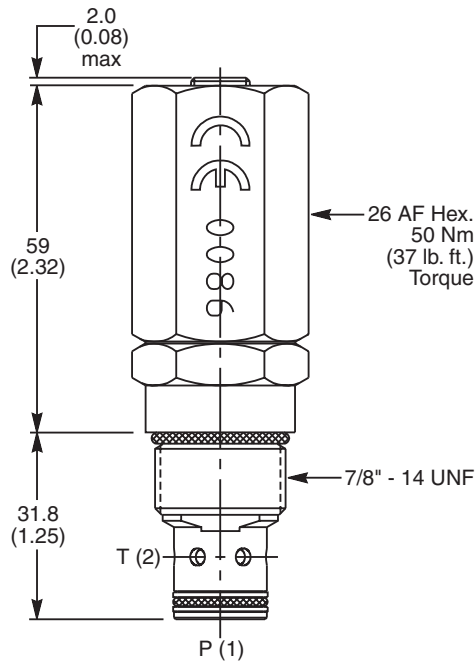

Ordering Information

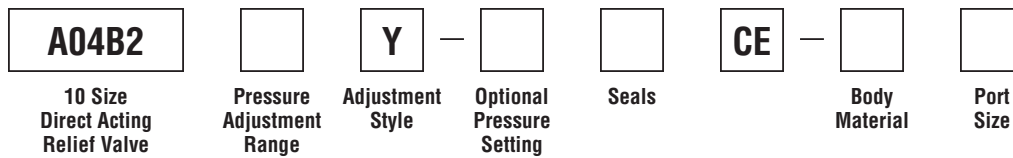

Code	Pressure Adjustment Range
F	2 - 100 Bar (29 - 1450 PSI)
H	5 - 210 Bar (72 - 3000 PSI)
P	5 - 420 Bar (72 - 6000 PSI)

Code	Seals / Kit No.
N	Nitrile, Buna-N (Std.) / (SK30503NP-1)
V	Fluorocarbon / (SK30503VP-1)

Code	Body Material
Omit	Steel
A	Aluminum

Code	Adjustment Style / Kit No.
Y	Non Adjustable Preset (Std.)

Code	Port Size	Body Part No.
Omit	Cartridge Only	
4P	1/4" NPTF	(B10-2-*4P)
6P	3/8" NPTF	(B10-2-*6P)
8P	1/2" NPTF	(B10-2-*8P)
6T	SAE-6	(B10-2-*6T)
8T	SAE-8	(B10-2-*8T)
T8T	SAE-8	(B10-2-T8T)†
6B	3/8" BSPG	(B10-2-6B)†

Optional Pressure Setting	
Setting must be specified (Bar)	

* Add "A" for aluminum, omit for steel.
 † Steel body only.

Technical Information

- CV** Check Valves
- SH** Shuttle Valves
- LM** Load/Motor Controls
- FC** Flow Controls
- PC** Pressure Controls
- LE** Logic Elements
- DC** Directional Controls
- MV** Manual Valves
- SV** Solenoid Valves
- PV** Proportional Valves
- CE** Coils & Electronics
- BC** Bodies & Cavities
- TD** Technical Data

General Description

Direct Acting Spool-Type Relief Valve. For additional information see Technical Tips on pages PC1-PC6.

Features

- High flow capacity
- Fast response with good stability
- Low pressure setting
- Full 420 Bar 6000 PSI tank line back pressure
- Hardened working parts for maximum durability
- Adjustable, preset and tamperproof versions available
- All external parts zinc plated

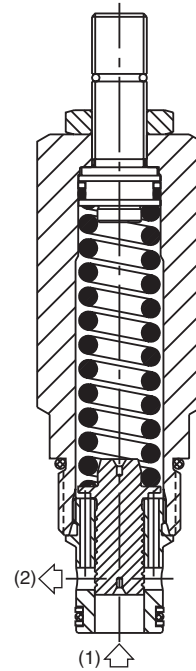
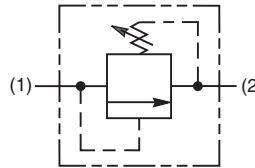
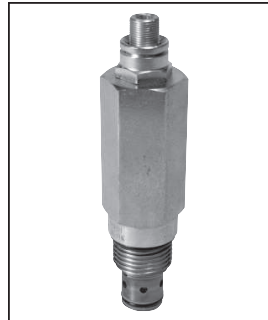

Specifications

Rated Flow	200 LPM (53 GPM)
Maximum Inlet Pressure	D - 2-50 Bar (29-725 PSI) F - 2-100 Bar (29-1450 PSI)
Maximum Pressure Setting	420 Bar (6000 PSI)
Maximum Tank Pressure	420 Bar (6000 PSI)
Leakage at 150 SSU (32 cSt)	25 ml/min. @ 50 Bar (725 PSI)
Cartridge Material	All parts steel. All operating parts hardened steel.
Operating Temp. Range/Seals	-40°C to +93.3°C (Nitrile) (-40°F to +200°F) -31.7°C to +121.1°C (Fluorocarbon) (-25°F to +250°F)
Fluid Compatibility/Viscosity	Mineral-based or synthetic with lubricating properties at viscosities of 45 to 2000 SSU (6 to 420 cSt)
Filtration	ISO Code 16/13, SAE Class 4 or better
Approx. Weight	0.28 kg (0.62 lbs.)
Cavity	C10-2 (See BC Section for more details)
Form Tool	Rougher None Finisher NFT10-2F

Performance Curve

(Pressure rise through cartridge only)

Flow vs. Inlet Pressure

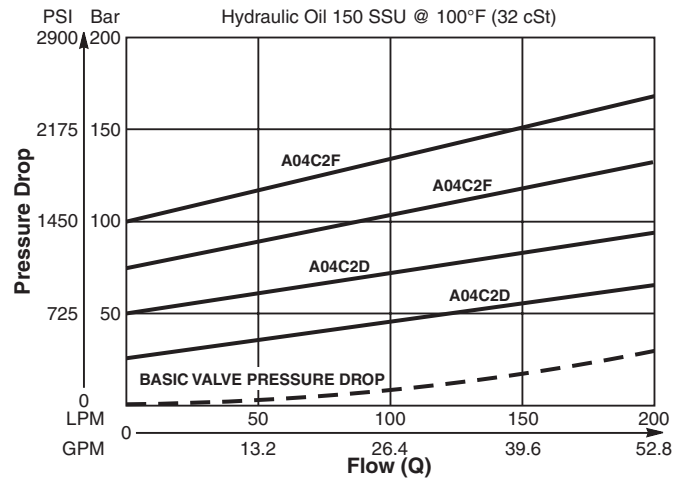

Dimensions Millimeters (Inches)

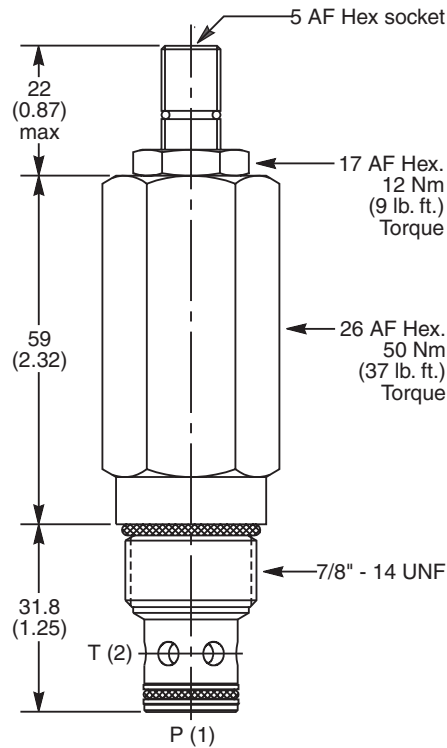

Ordering Information

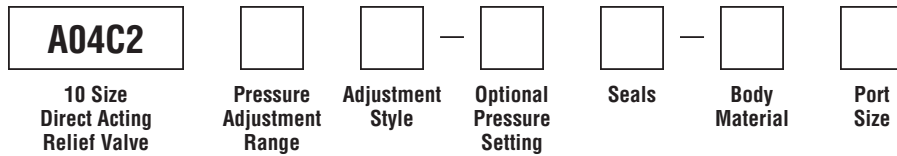

Code	Pressure Adjustment Range
D	2 - 50 Bar (29 - 725 PSI)
F	2 - 100 Bar (29 - 1450 PSI)

Code	Seals / Kit No.
N	Nitrile, Buna-N (Std.) / (SK30503N-1)
V	Fluorocarbon / (SK30503V-1)

Code	Body Material
Omit	Steel
A	Aluminum

Code	Adjustment Style / Kit No.
Z	Screw Adjust (Std.)
W	Knob Adjust (ASV014975)
T	Tamper Resistant Cap (TC1130)

Code	Port Size	Body Part No.
Omit	Cartridge Only	
4P	1/4" NPTF	(B10-2-*4P)
6P	3/8" NPTF	(B10-2-*6P)
8P	1/2" NPTF	(B10-2-*8P)
6T	SAE-6	(B10-2-*6T)
8T	SAE-8	(B10-2-*8T)
T8T	SAE-8	(B10-2-T8T)†
6B	3/8" BSPG	(B10-2-6B)†

Optional Pressure Setting	
Specify setting if required (Bar)	
A04C2D Standard Setting: 25 Bar (360 PSI) @ 15 LPM (4.0 GPM)	
A04C2F Standard Setting: 50 Bar (725 PSI) @ 15 LPM (4.0 GPM)	

* Add "A" for aluminum, omit for steel.
 † Steel body only.

Technical Information

CV Check Valves
SH Shuttle Valves
LM Load/Motor Controls
FC Flow Controls
PC Pressure Controls
LE Logic Elements
DC Directional Controls
MV Manual Valves
SV Solenoid Valves
PV Proportional Valves
CE Coils & Electronics
BC Bodies & Cavities
TD Technical Data

General Description

Differential Area Relief Valve. For additional information see Technical Tips on pages PC1-PC6.

Features

- Hardened, precision ground parts for durability
- Spherical poppets for low leakage
- High flow capacity
- Internal mechanical stop limits poppet travel eliminating spring solidification
- All external parts have yellow zinc dichromate. This coating is ideal for salt spray applications.

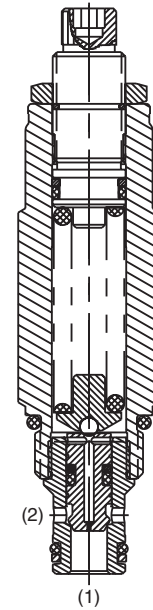
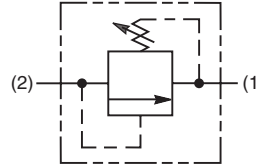

Specifications

Rated Flow	45 LPM (12 GPM)
Maximum Inlet Pressure	380 Bar (5500 PSI)
Maximum Pressure Setting	350 Bar (5000 PSI)
Maximum Tank Pressure	350 Bar (5000 PSI)
Reseat Pressure	75% of crack pressure
Leakage at 150 SSU (32 cSt)	10 drops/min. (.67 cc/min.) @75% of crack pressure
Cartridge Material	All parts steel. All operating parts hardened steel.
Operating Temp. Range/Seals	-40°C to +93.3°C (Nitrile) (-40°F to +200°F) -31.7°C to +121.1°C (Fluorocarbon) (-25°F to +250°F)
Fluid Compatibility/Viscosity	Mineral-based or synthetic with lubricating properties at viscosities of 45 to 2000 SSU (6 to 420 cSt)
Filtration	ISO Code 16/13, SAE Class 4 or better
Approx. Weight	.19 kg (.43 lbs.)
Cavity	C08-2 (See BC Section for more details)
Form Tool	Rougher None Finisher NFT08-2F

Performance Curve

Flow vs. Inlet Pressure

(Pressure rise through cartridge only)

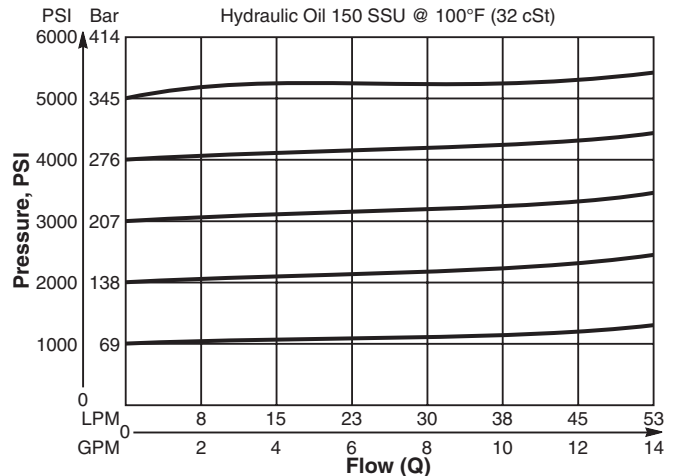

Dimensions Millimeters (Inches)

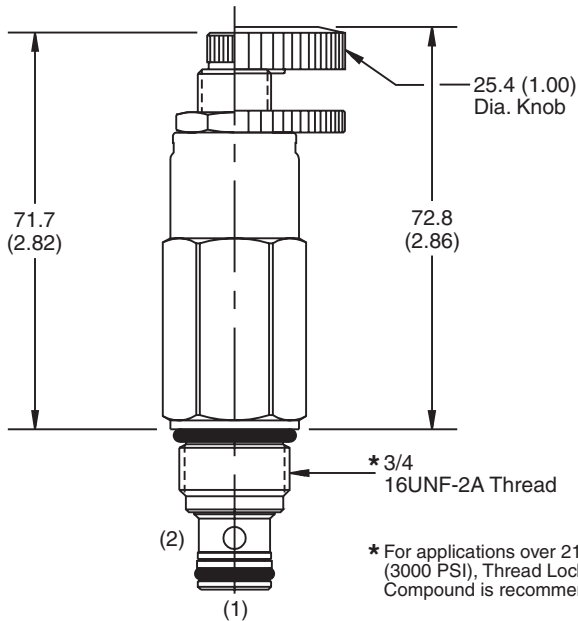

Screw/Knob Version

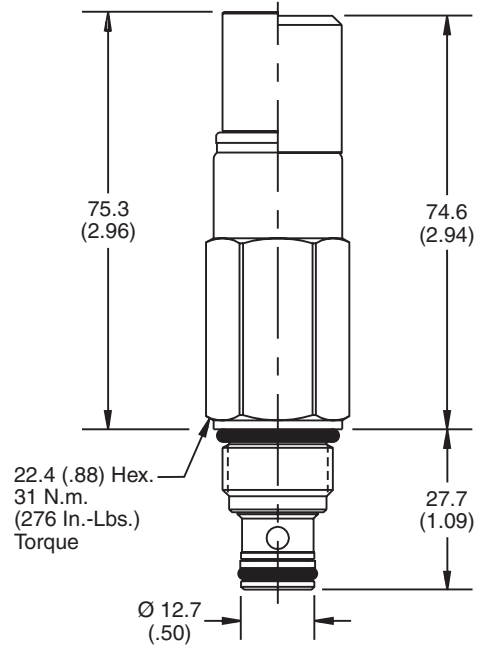

Fixed Cap/Tamper Resistant Version

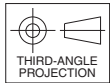

* For applications over 210 Bar (3000 PSI), Thread Lock Compound is recommended.

Ordering Information

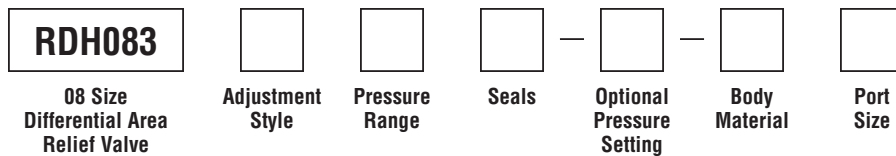

Code	Adjustment Style / Kit No.
F	Fixed style, preset at factory.
K	Knob Adjust (717784-10)
S	Screw Adjust
T	Tamper Resistant Cap (718083)

Code	Seals / Kit No.
Omit	Nitrile / (SK08-2N)
V	Fluorocarbon / (SK08-2V)

Code	Body Material
Omit	Steel
A	Aluminum

Code	Pressure Range
15	6.9 - 103 Bar (100 - 1500 PSI) Standard Setting: 51.7 Bar (750 PSI) @ crack pressure approximately .95 LPM (.25 GPM)
30	69 - 207 Bar (1000 - 3000 PSI) Standard Setting: 103 Bar (1500 PSI) @ crack pressure approximately .95 LPM (.25 GPM)
50	138 - 345 Bar (2000 - 5000 PSI) Standard Setting: 172.4 Bar (2500 PSI) @ crack pressure approximately .95 LPM (.25 GPM)

Optional Pressure Setting
Pressure \pm 10 i.e. 235 = 2350 PSI (Omit if standard setting is used) Setting Range: 100 to 5000 PSI All settings at crack pressure, approximately .95 LPM (.25 GPM)

Code	Port Size	Body Part No.
Omit	Cartridge Only	
4P	1/4" NPTF	(B08-2-*4P)
6P	3/8" NPTF	(B08-2-*6P)
4T	SAE-4	(B08-2-*4T)
6T	SAE-6	(B08-2-*6T)
6B	3/8" BSPG	(B08-2-*6B)

* Add "A" for aluminum, omit for steel.

- CV
Check Valves
- SH
Shuttle Valves
- LM
Load/Motor Controls
- FC
Flow Controls
- PC
Pressure Controls
- LE
Logic Elements
- DC
Directional Controls
- MV
Manual Valves
- SV
Solenoid Valves
- PV
Proportional Valves
- CE
Coils & Electronics
- BC
Bodies & Cavities
- TD
Technical Data

Technical Information

- CV** Check Valves
- SH** Shuttle Valves
- LM** Load/Motor Controls
- FC** Flow Controls
- PC** Pressure Controls
- LE** Logic Elements
- DC** Directional Controls
- MV** Manual Valves
- SV** Solenoid Valves
- PV** Proportional Valves
- CE** Coils & Electronics
- BC** Bodies & Cavities
- TD** Technical Data

General Description

Differential Area Relief Valve. For additional information see Technical Tips on pages PC1-PC6.



Features

- Hardened, precision ground parts for durability
- Internal mechanical stop limits poppet travel eliminating spring solidification
- Spherical poppets for low leakage
- “D”-Ring eliminates backup rings
- All external parts have yellow zinc dichromate. This coating is ideal for salt spray applications.
- High flow capacity

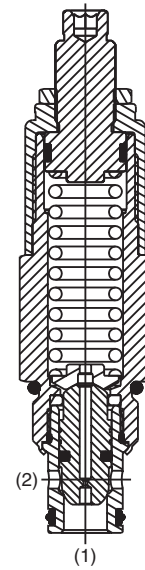
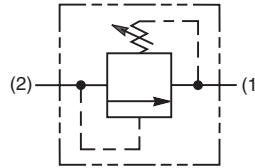
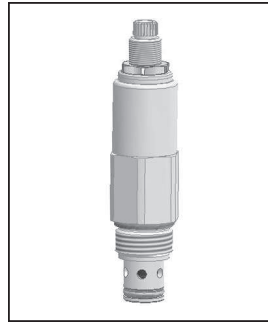

Specifications

Rated Flow	75 LPM (20 GPM)
Maximum Inlet Pressure	380 Bar (5500 PSI)
Maximum Pressure Setting	350 Bar (5000 PSI)
Maximum Tank Pressure	350 Bar (5000 PSI)
Reseat Pressure	85% of crack pressure
Leakage at 150 SSU (32 cSt)	5 drops/min. (.33 cc/min.) @75% of crack pressure
Cartridge Material	All parts steel. All operating parts hardened steel.
Operating Temp. Range/Seals	-45°C to +93.3°C (“D”-Ring) (-50°F to +200°F) -31.7°C to +121.1°C (Fluorocarbon) (-25°F to +250°F)
Fluid Compatibility/Viscosity	Mineral-based or synthetic with lubricating properties at viscosities of 45 to 2000 SSU (6 to 420 cSt)
Filtration	ISO Code 16/13, SAE Class 4 or better
Approx. Weight	.23 kg (0.5 lbs.)
Cavity	C10-2 (See BC Section for more details)
Form Tool	Rougher None Finisher NFT10-2F

Performance Curve

Flow vs. Inlet Pressure

(Pressure rise through cartridge only)

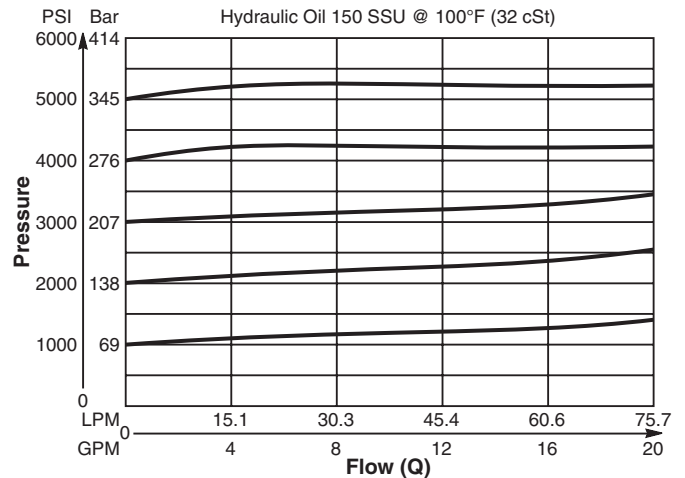

Dimensions Millimeters (Inches)

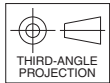
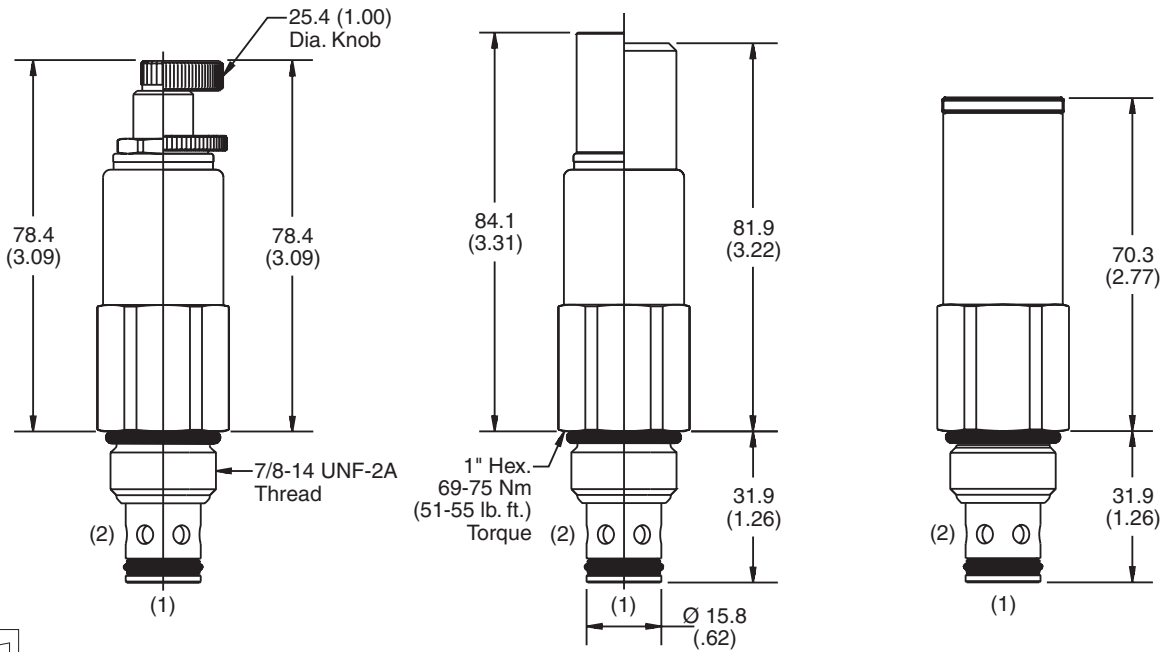

Screw/Knob Version

Fixed Cap/Tamper Resistant Version

Non-Adjustable Version

Ordering Information

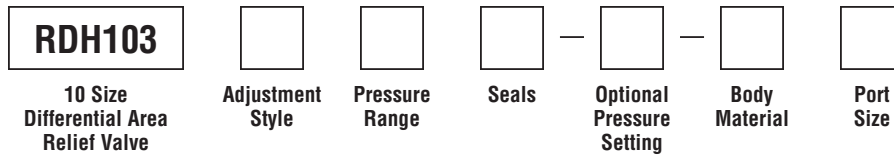

Code	Adjustment Style / Kit No.
F	Fixed style, preset at factory.
K	Knob Adjust (717784-10)
N	Non-Adjustable
S	Screw Adjust
T	Tamper Resistant Cap (717943)

Code	Seals / Kit No.
Omit	"D"-Ring / (SK10-2)
N	Nitrile / (SK10-2N)
V	Fluorocarbon / (SK10-2V)

Code	Body Material
Omit	Steel
A	Aluminum

Code	Pressure Range
10	6.9 - 69 Bar (100 - 1000 PSI) Standard Setting: 34.5 Bar (500 PSI) @ .95 LPM (.25 GPM)
20	34.5 - 138 Bar (500 - 2000 PSI) Standard Setting: 69 Bar (1000 PSI) @ .95 LPM (.25 GPM)
30	34.5 - 207 Bar (500 - 3000 PSI) Standard Setting: 103.5 Bar (1500 PSI) @ .95 LPM (.25 GPM)
50	34.5 - 345 Bar (500 - 5000 PSI) Standard Setting: 172.4 Bar (2500 PSI) @ .95 LPM (.25 GPM)

Optional Pressure Setting
Pressure \pm 10 i.e. 235 = 2350 PSI (Omit if standard setting is used) Setting Range: 100 to 5000 PSI All settings at .95 LPM (.25 GPM)

Code	Port Size	Body Part No.
Omit	Cartridge Only	
4P	1/4" NPTF	(B10-2-*4P)
6P	3/8" NPTF	(B10-2-*6P)
8P	1/2" NPTF	(B10-2-*8P)
6T	SAE-6	(B10-2-*6T)
8T	SAE-8	(B10-2-*8T)
6B	3/8" BSPG	(B10-2-6B)†

* Add "A" for aluminum, omit for steel.
 † Steel body only.

Technical Information

- CV Check Valves
- SH Shuttle Valves
- LM Load/Motor Controls
- FC Flow Controls
- PC Pressure Controls
- LE Logic Elements
- DC Directional Controls
- MV Manual Valves
- SV Solenoid Valves
- PV Proportional Valves
- CE Coils & Electronics
- BC Bodies & Cavities
- TD Technical Data

General Description

Direct Acting Relief Valve with Reverse Free Flow Check Valve. For additional information see Technical Tips on pages PC1-PC6.

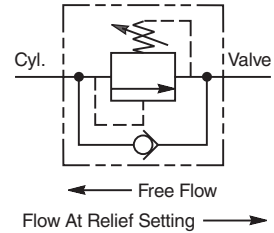

Features

- Hardened, precision ground parts for durability
- Rugged steel body construction
- Spherical poppets for low leakage
- Built-in cartridge check reduces plumbing
- Differential area cartridge relief for high flow capacity
- All external parts have yellow zinc dichromate. This coating is ideal for salt spray applications.
- “D”-Ring eliminates backup rings

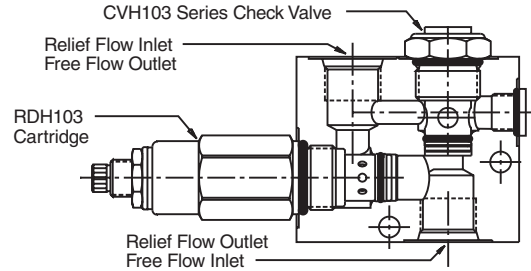

Specifications

Maximum Flow	60 LPM (16 GPM)
Maximum Inlet Pressure	380 Bar (5500 PSI)
Maximum Pressure Setting	350 Bar (5000 PSI)
Reseat Pressure	85% of crack pressure
Leakage at 150 SSU (32 cSt)	5 drops/min. (.33 cc/min.) @ 75% of crack pressure
Cartridge Material	All parts steel. All operating parts hardened steel.
Body Material	Steel
Operating Temp. Range/Seals	-45°C to +93.3°C (“D”-Ring) (-50°F to +200°F) -31.7°C to +121.1°C (Fluorocarbon) (-25°F to +250°F)
Fluid Compatibility/Viscosity	Mineral-based or synthetic with lubricating properties at viscosities of 45 to 2000 SSU (6 to 420 cSt)
Filtration	ISO Code 16/13, SAE Class 4 or better
Approx. Weight	1.2 kg (2.7 lbs.)

Performance Curve

Flow vs. Inlet Pressure
(Pressure rise through cartridge only)

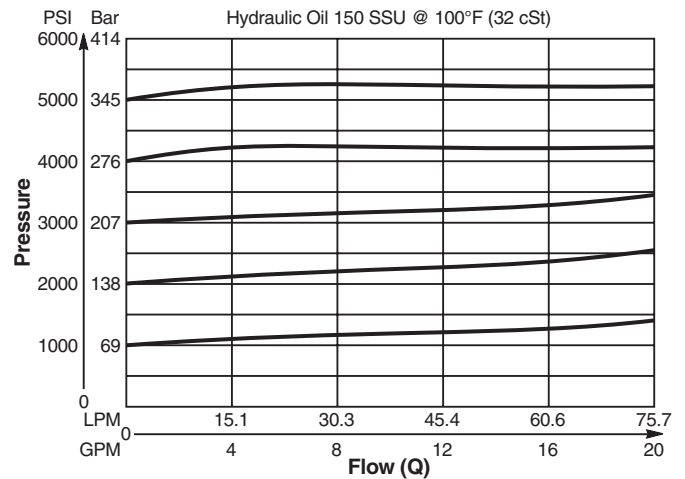

Dimensions Millimeters (Inches)

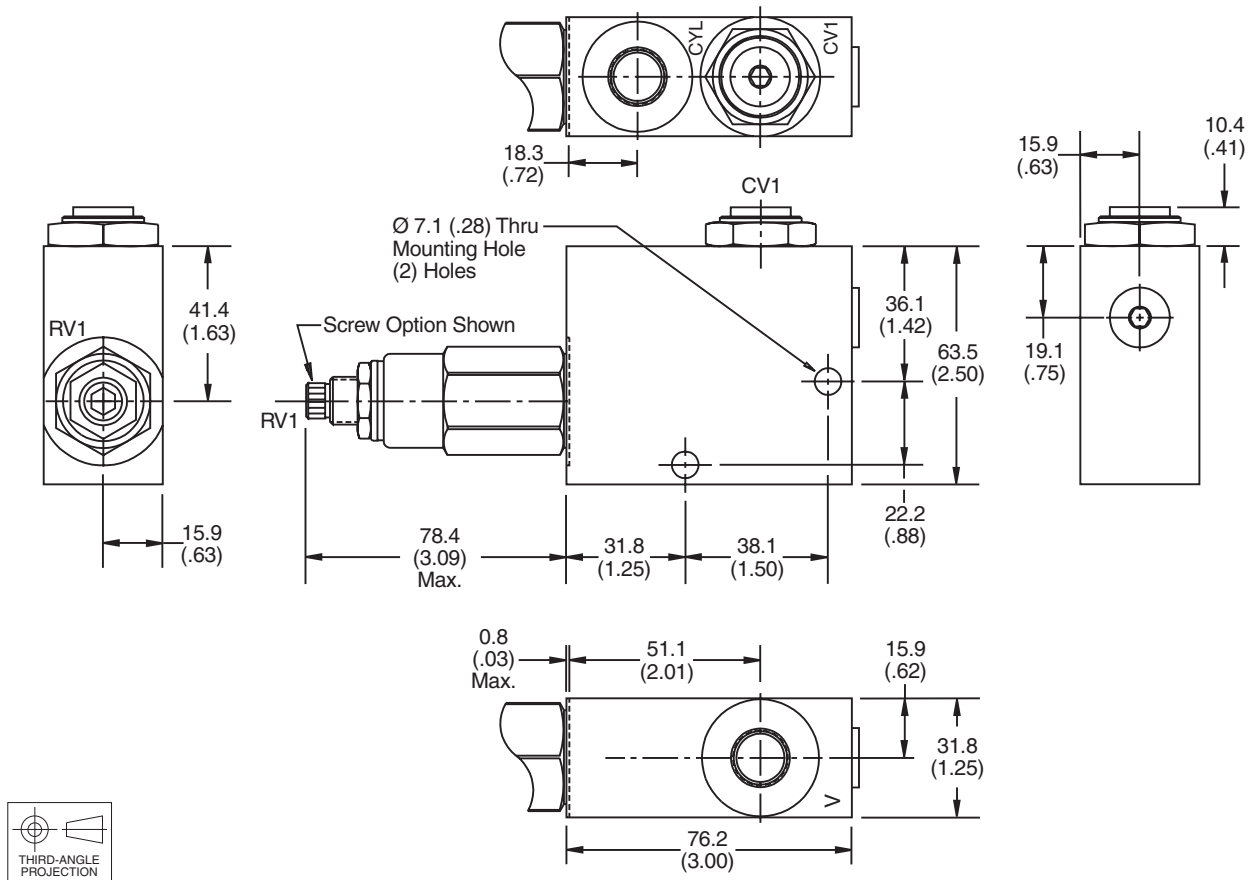

Ordering Information

RDCH103	<input type="checkbox"/>	<input type="checkbox"/>	<input type="checkbox"/>	<input type="checkbox"/>	<input type="checkbox"/>	<input type="checkbox"/>
10 Size Direct Acting Relief Valve With Reverse Flow Check	Adjustment Style	Pressure Range	Optional Pressure Setting	Check Valve Cracking Pressure	Seals	Port Size

Code	Adjustment Style / Kit No.
F	Fixed style, preset at factory.
K	Knob Adjust (717784-10)
S	Screw Adjust
T	Tamper Resistant Cap (717943)

Code	Pressure Range
10	6.9 - 69 Bar (100 - 1000 PSI) Standard Setting: 34.5 Bar (500 PSI) @ .95 LPM (.25 GPM)
20	34.5 - 138 Bar (500 - 2000 PSI) Standard Setting: 69 Bar (1000 PSI) @ .95 LPM (.25 GPM)
30	34.5 - 207 Bar (500 - 3000 PSI) Standard Setting: 103.5 Bar (1500 PSI) @ .95 LPM (.25 GPM)
50	34.5 - 345 Bar (500 - 5000 PSI) Standard Setting: 172.4 Bar (2500 PSI) @ .95 LPM (.25 GPM)

Code	Optional Pressure Setting
Omit	Pressure + 10 i.e. 235 = 2350 PSI (Omit if standard setting is used)
	Setting Range: 100 to 5000 PSI All settings at .95 LPM (.25 GPM)

Code	Cracking Pressure
Omit	0.3 Bar (5 PSI)
P20	1.4 Bar (20 PSI)
P50	3.5 Bar (50 PSI)
P65	4.5 Bar (65 PSI)
P100	6.9 Bar (100 PSI)

Code	Seals / Kit No.
Omit	"D"-Ring / (SK10-2)
N	Nitrile / (SK10-2N)
V	Fluorocarbon / (SK10-2V)

Code	Port Size	Part No.
8T	SAE-8	830313

Individual body requires 1 SAE 5 plug.
 Part number 5 HP50N-S.

Technical Information

- CV** Check Valves
- SH** Shuttle Valves
- LM** Load/Motor Controls
- FC** Flow Controls
- PC** Pressure Controls
- LE** Logic Elements
- DC** Directional Controls
- MV** Manual Valves
- SV** Solenoid Valves
- PV** Proportional Valves
- CE** Coils & Electronics
- BC** Bodies & Cavities
- TD** Technical Data

General Description

Differential Area Relief Valve. For additional information see Technical Tips on pages PC1-PC6.

Features

- Hardened, precision ground parts for durability
- Compact size for reduced space requirements
- Low leakage design
- Fast response
- All external parts zinc plated

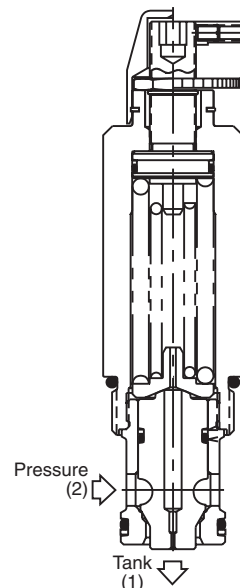
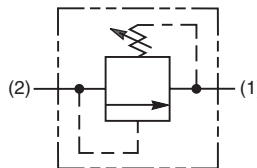

Specifications

Rated Flow	151 LPM (40 GPM)
Maximum Inlet Pressure	240 Bar (3500 PSI)
Maximum Pressure Setting	210 Bar (3000 PSI)
Maximum Tank Pressure	210 Bar (3000 PSI)
Reseat Pressure	80% of crack pressure
Leakage at 150 SSU (32 cSt)	10 drops/min. (.66 cc/min.) @75% of crack pressure
Cartridge Material	All parts steel. All operating parts hardened steel.
Operating Temp. Range/Seals	-40°C to +93.3°C (Nitrile) (-40°F to +200°F) -31.7°C to +121.1°C (Fluorocarbon) (-25°F to +250°F)
Fluid Compatibility/Viscosity	Mineral-based or synthetic with lubricating properties at viscosities of 45 to 2000 SSU (6 to 420 cSt)
Filtration	ISO Code 16/13, SAE Class 4 or better
Approx. Weight	.23 kg (0.5 lbs.)
Cavity	C16-2 (See BC Section for more details)
Form Tool	Rougher None Finisher NFT16-2F

Performance Curve

Flow vs. Inlet Pressure

(Pressure rise through cartridge only)

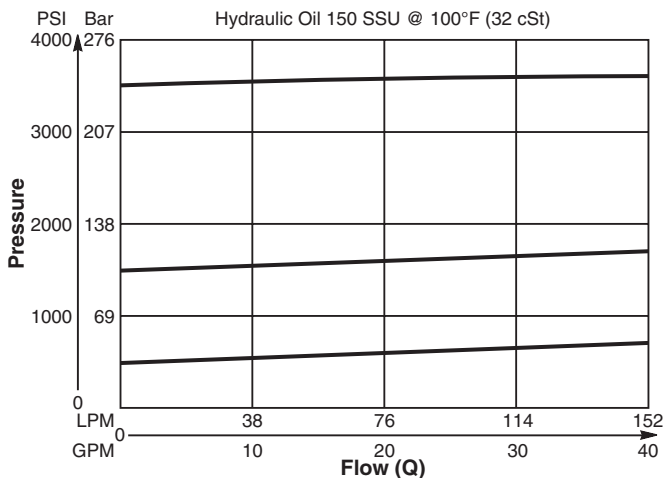

Dimensions Millimeters (Inches)

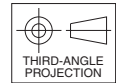
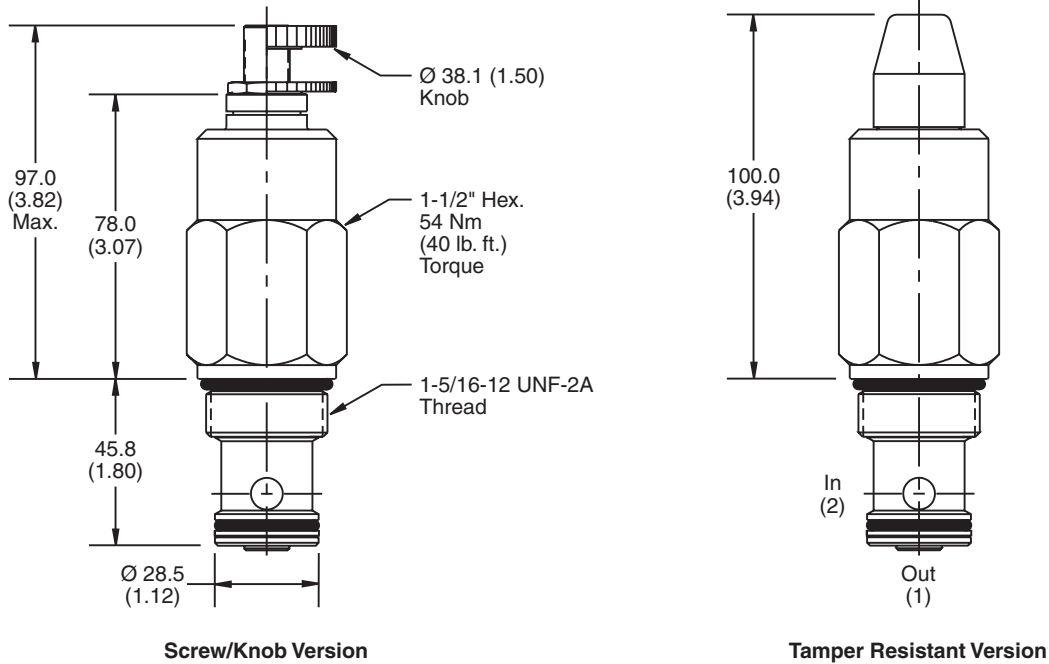

Ordering Information

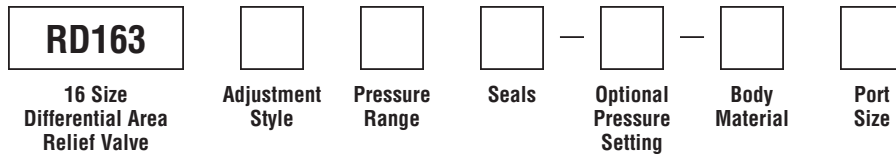

Code	Adjustment Style / Kit No.
K	Knob Adjust (840208K)
S	Screw Adjust
T	Tamper Resistant Cap (717783)

Code	Seals / Kit No.
Omit	Nitrile / (SK16-2)
V	Fluorocarbon / (SK16-2V)

Code	Body Material
Omit	Steel
A	Aluminum

Code	Pressure Range
10	13.8 - 69 Bar (200 - 1000 PSI) Standard Setting: 34.5 Bar (500 PSI) @ 11.3 LPM (3 GPM)
20	27.6 - 138 Bar (400 - 2000 PSI) Standard Setting: 69 Bar (1000 PSI) @ 11.3 LPM (3 GPM)
30	41.4 - 207 Bar (600 - 3000 PSI) Standard Setting: 103.5 Bar (1500 PSI) @ 11.3 LPM (3 GPM)

Optional Pressure Setting
Pressure \pm 10 i.e. 235 = 2350 PSI (Omit if standard setting is used) Setting Range: 100 to 3000 PSI All settings at 11.3 LPM (3 GPM)

Code	Port Size	Body Part No.
Omit	Cartridge Only	
12P	3/4" NPTF	(B16-2-*12P)
16P	1" NPTF	(B16-2-*16P)
8T	SAE-8	(B16-2-*8T)
12T	SAE-12	(B16-2-*12T)
16T	SAE-16	(B16-2-*16T)
12B	3/4" BSPG	(B16-2-12B)†
16B	1" BSPG	(B16-2-*16B)

* Add "A" for aluminum, omit for steel.
 † Steel body only.

- CV**
Check Valves
- SH**
Shuttle Valves
- LM**
Load/Motor Controls
- FC**
Flow Controls
- PC**
Pressure Controls
- LE**
Logic Elements
- DC**
Directional Controls
- MV**
Manual Valves
- SV**
Solenoid Valves
- PV**
Proportional Valves
- CE**
Coils & Electronics
- BC**
Bodies & Cavities
- TD**
Technical Data

Technical Information

- CV** Check Valves
- SH** Shuttle Valves
- LM** Load/Motor Controls
- FC** Flow Controls
- PC** Pressure Controls
- LE** Logic Elements
- DC** Directional Controls
- MV** Manual Valves
- SV** Solenoid Valves
- PV** Proportional Valves
- CE** Coils & Electronics
- BC** Bodies & Cavities
- TD** Technical Data

General Description

Pilot Operated Spool-Type Relief Valve
For additional information see
Technical Tips on pages PC1-PC6.



Features

- Hardened, precision ground parts for durability
- Low profile adapter for minimal space requirements
- Fully guided pilot for more consistent reseal
- Steel adapters are coated with yellow zinc dichromate for protection from salt spray
- Polyurethane "D"-Ring eliminates backup rings and prevents hydrolysis
- Internal screening protects pilot spring from debris

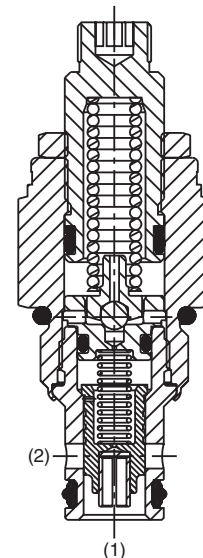
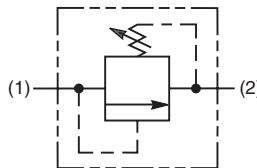
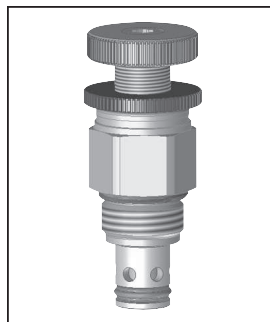

Specifications

Rated Flow	75.8 LPM (20 GPM)
Maximum Inlet Pressure	380 Bar (5500 PSI)
Maximum Pressure Setting	350 Bar (5000 PSI)
Maximum Tank Pressure	350 Bar (5000 PSI)
Reseat Pressure	90% of crack pressure
Leakage at 150 SSU (32 cSt)	5 cc per 100 PSI (6.8 Bar) setting
Cartridge Material	All parts steel. All operating parts hardened steel.
Operating Temp. Range/Seals	-45°C to +93.3°C ("D"-Ring) (-50°F to +200°F) -31.7°C to +121.1°C (Fluorocarbon) (-25°F to +250°F)
Fluid Compatibility/ Viscosity	Mineral-based or synthetic with lubricating properties at viscosities of 45 to 2000 SSU (6 to 420 cSt)
Filtration	ISO Code 16/13, SAE Class 4 or better
Approx. Weight	.09 kg (.20 lbs.)
Cavity	C08-2 (See BC Section for more details)
Form Tool	Rougher None Finisher NFT08-2F

Performance Curves

Flow vs. Inlet Pressure

(Pressure rise through cartridge only)

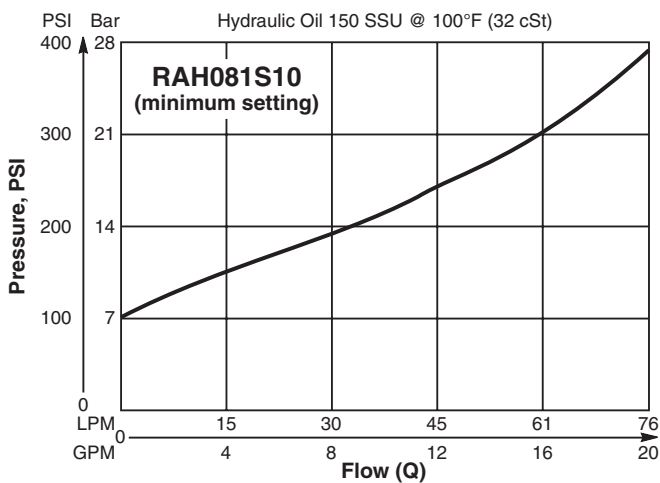
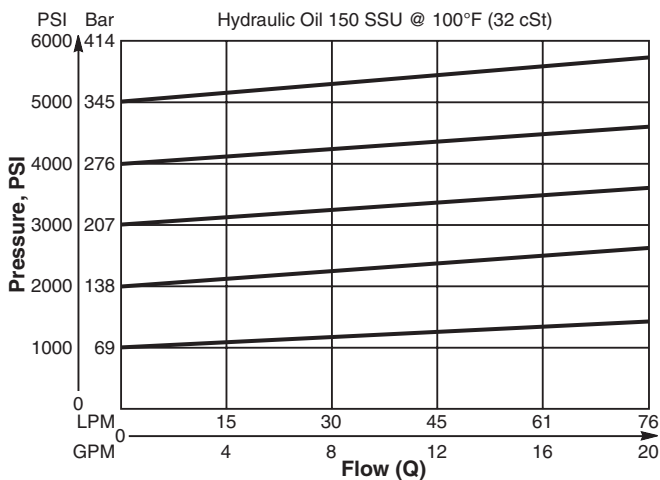

Dimensions Millimeters (Inches)

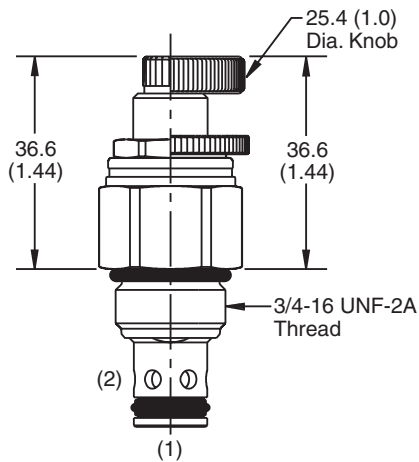

Screw/Knob Version

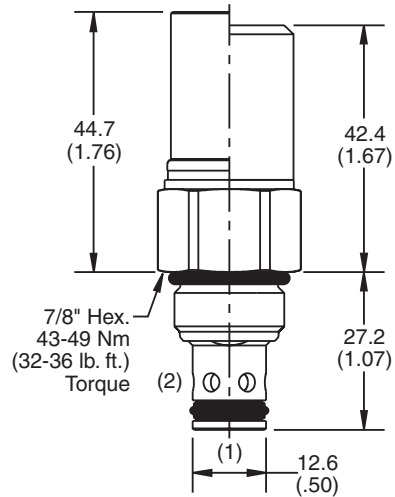

Fixed Cap/Tamper Resistant Version

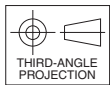

Ordering Information

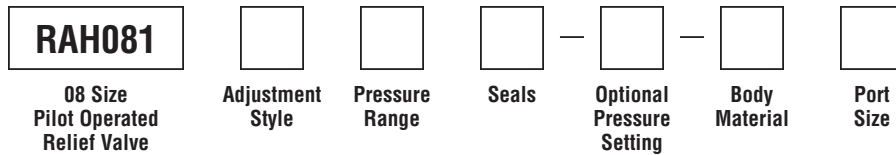

Code	Adjustment Style / Kit No.
F	Fixed style, preset at factory.
K	Knob Adjust (717784-10)
S	Screw Adjust
T	Tamper Resistant Cap (717943)

Code	Seals / Kit No.
Omit	"D"-Ring / (SK08-2)
N	Nitrile / (SK08-2N)
V	Fluorocarbon / (SK08-2V)

Code	Body Material
Omit	Steel
A	Aluminum

Code	Pressure Range
10	6.9 - 69 Bar (100 - 1000 PSI) Standard Setting: 34.5 Bar (500 PSI) @ crack pressure, approximately .95 LPM (.25 GPM)
20	6.9 - 138 Bar (100 - 2000 PSI) Standard Setting: 69 Bar (1000 PSI) @ crack pressure, approximately .95 LPM (.25 GPM)
30	13.8 - 207 Bar (200 - 3000 PSI) Standard Setting: 103.5 Bar (1500 PSI) @ crack pressure, approximately .95 LPM (.25 GPM)
50	13.8 - 345 Bar (200 - 5000 PSI) Standard Setting: 172.4 Bar (2500 PSI) @ crack pressure, approximately .95 LPM (.25 GPM)

Optional Pressure Setting
Pressure \pm 10 i.e. 235 = 2350 PSI (Omit if standard setting is used) Setting Range: 100 to 5000 PSI All settings at crack pressure, approximately .95 LPM (.25 GPM)

Code	Port Size	Body Part No.
Omit	Cartridge Only	
4P	1/4" NPTF	(B08-2-*4P)
6P	3/8" NPTF	(B08-2-*6P)
4T	SAE-4	(B08-2-*4T)
6T	SAE-6	(B08-2-*6T)
6B	3/8" BSPG	(B08-2-*6B)

* Add "A" for aluminum, omit for steel.

Technical Information

- CV** Check Valves
- SH** Shuttle Valves
- LM** Load/Motor Controls
- FC** Flow Controls
- PC** Pressure Controls
- LE** Logic Elements
- DC** Directional Controls
- MV** Manual Valves
- SV** Solenoid Valves
- PV** Proportional Valves
- CE** Coils & Electronics
- BC** Bodies & Cavities
- TD** Technical Data

General Description

Pilot Operated Spool-Type Relief Valve
For addition information see Technical Tips on pages PC1-PC6.



Features

- Hardened, precision ground parts for durability
- Low profile adapter for minimal space requirements
- Fully guided poppet for more consistent reseal
- Steel adapters are coated with yellow zinc dichromate for protection from salt spray
- Polyurethane "D"-Ring eliminates backup rings and prevents hydrolysis
- Internal screening protects pilot spring from debris

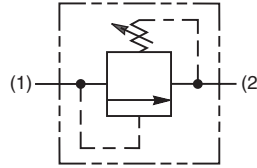
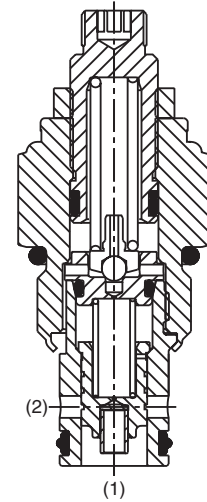

Specifications

Rated Flow	113 LPM (30 GPM)
Maximum Inlet Pressure	380 Bar (5500 PSI)
Maximum Pressure Setting	350 Bar (5000 PSI)
Maximum Tank Pressure	350 Bar (5000 PSI)
Reseat Pressure	90% of crack pressure
Leakage at 150 SSU (32 cSt)	5 cc per 100 PSI (6.8 Bar) setting
Cartridge Material	All parts steel. All operating parts hardened steel.
Operating Temp. Range/Seals	-45°C to +93.3°C ("D"-Ring) (-50°F to +200°F) -31.7°C to +121.1°C (Fluorocarbon) (-25°F to +250°F)
Fluid Compatibility/ Viscosity	Mineral-based or synthetic with lubricating properties at viscosities of 45 to 2000 SSU (6 to 420 cSt)
Filtration	ISO Code 16/13, SAE Class 4 or better
Approx. Weight	.23 kg (.50 lbs.)
Cavity	C10-2 (See BC Section for more details)
Form Tool	Rougher None Finisher NFT10-2F

Performance Curves

Flow vs. Inlet Pressure

(Pressure rise through cartridge only)

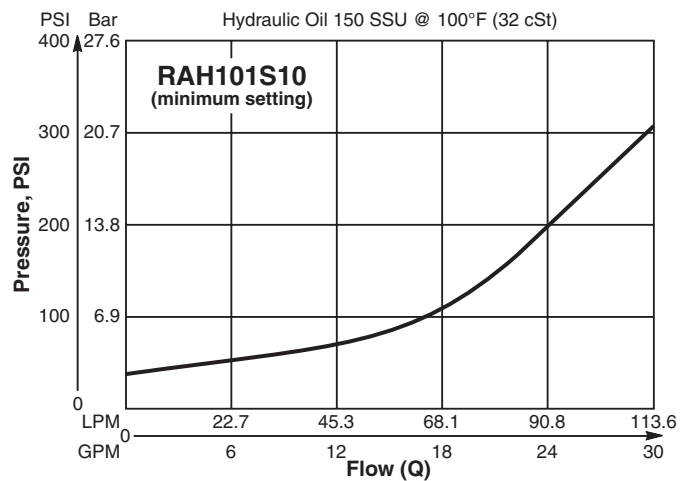
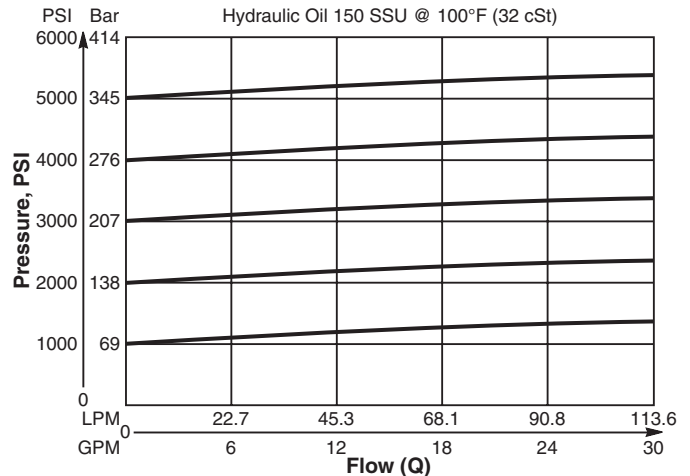

Dimensions Millimeters (Inches)

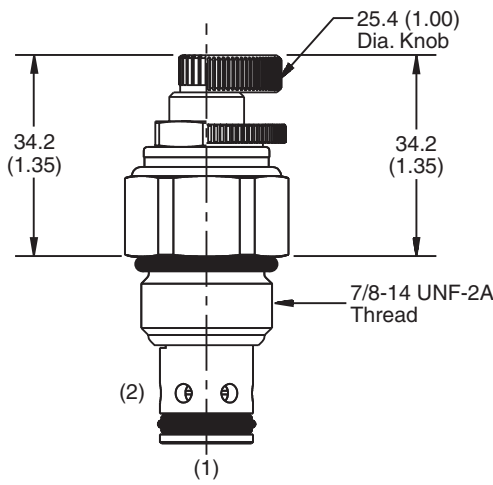

Screw/Knob Version

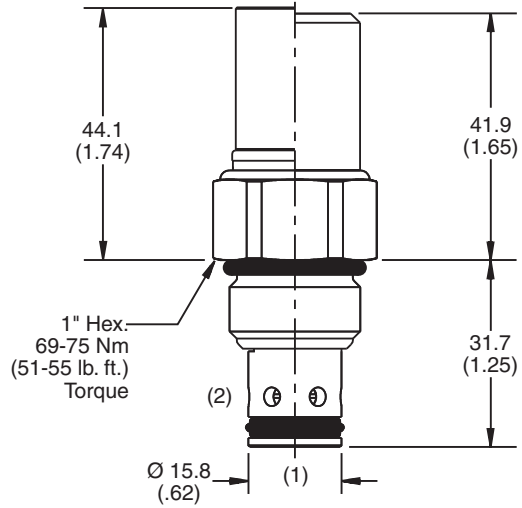

Fixed Cap/Tamper Resistant Version

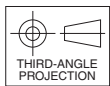

Ordering Information

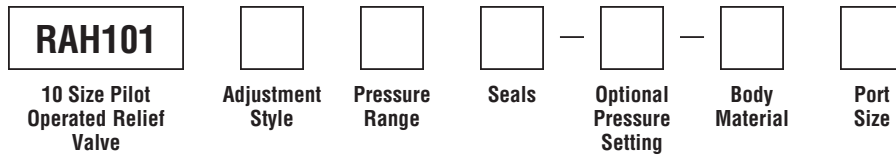

Code	Adjustment Style / Kit No.
F	Fixed style, preset at factory.
K	Knob Adjust (717784-10)
S	Screw Adjust
T	Tamper Resistant Cap (718083)

Code	Seals / Kit No.
Omit	"D"-Ring / (SK10-2)
N	Nitrile / (SK10-2N)
V	Fluorocarbon / (SK10-2V)

Code	Body Material
Omit	Steel
A	Aluminum

Code	Pressure Range
10	6.9 - 69 Bar (100 - 1000 PSI) Standard Setting: 34.5 Bar (500 PSI) @ crack pressure, approximately .95 LPM (.25 GPM)
20	6.9 - 138 Bar (100 - 2000 PSI) Standard Setting: 69 Bar (1000 PSI) @ crack pressure, approximately .95 LPM (.25 GPM)
30	13.8 - 207 Bar (200 - 3000 PSI) Standard Setting: 103.5 Bar (1500 PSI) @ crack pressure, approximately .95 LPM (.25 GPM)
50	13.8 - 345 Bar (200 - 5000 PSI) Standard Setting: 172.4 Bar (2500 PSI) @ crack pressure, approximately .95 LPM (.25 GPM)

Optional Pressure Setting
Pressure ÷ 10 i.e. 235 = 2350 PSI (Omit if standard setting is used)
Setting Range: 100 to 5000 PSI All settings at crack pressure, approximately .95 LPM (.25 GPM)

Code	Port Size	Body Part No.
Omit	Cartridge Only	
4P	1/4" NPTF	(B10-2-*4P)
6P	3/8" NPTF	(B10-2-*6P)
8P	1/2" NPTF	(B10-2-*8P)
6T	SAE-6	(B10-2-*6T)
8T	SAE-8	(B10-2-*8T)
T8T	SAE-8	(B10-2-T8T)†
6B	3/8" BSPG	(B10-2-6B)†

* Add "A" for aluminum, omit for steel.
 † Steel body only.

Technical Information

- CV** Check Valves
- SH** Shuttle Valves
- LM** Load/Motor Controls
- FC** Flow Controls
- PC** Pressure Controls
- LE** Logic Elements
- DC** Directional Controls
- MV** Manual Valves
- SV** Solenoid Valves
- PV** Proportional Valves
- CE** Coils & Electronics
- BC** Bodies & Cavities
- TD** Technical Data

General Description

Pilot Operated Spool-Type Relief Valve. For additional information see Technical Tips on pages PC1-PC6.

Features

- Low override curve
- Ball-type pilot for added stability
- High accuracy - pilot operated design
- Hardened, precision ground parts for durability
- Compact size for reduced space requirements
- All external parts have yellow zinc dichromate. This coating is ideal for salt spray applications.

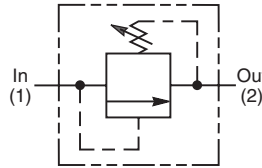
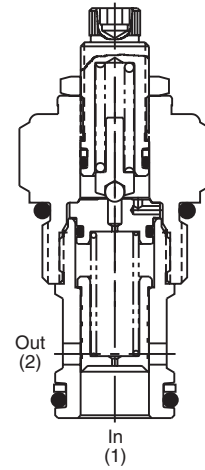

Specifications

Rated Flow	189.5 LPM (50 GPM)
Maximum Inlet Pressure	380 Bar (5500 PSI)
Maximum Pressure Setting	350 Bar (5000 PSI)
Reseat Pressure	80% of crack pressure
Leakage at 150 SSU (32 cSt)	82 cc/min. (5 cu. in./min.) @ 75% of crack pressure
Cartridge Material	All parts steel. All operating parts hardened steel.
Operating Temp. Range/Seals	-40°C to +93.3°C (Nitrile) (-40°F to +200°F) -31.7°C to +121.1°C (Fluorocarbon) (-25°F to +250°F)
Fluid Compatibility/Viscosity	Mineral-based or synthetic with lubricating properties at viscosities of 45 to 2000 SSU (6 to 420 cSt)
Filtration	ISO Code 16/13, SAE Class 4 or better
Approx. Weight	.22 kg (.48 lbs.)
Cavity	C12-2
Form Tool	Rougher None Finisher NFT12-2F

Performance Curve

Flow vs. Inlet Pressure

(Pressure rise through cartridge only)

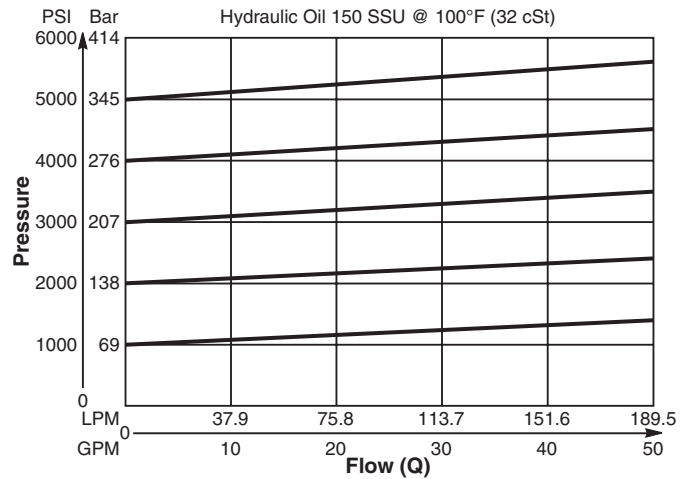

Dimensions Millimeters (Inches)

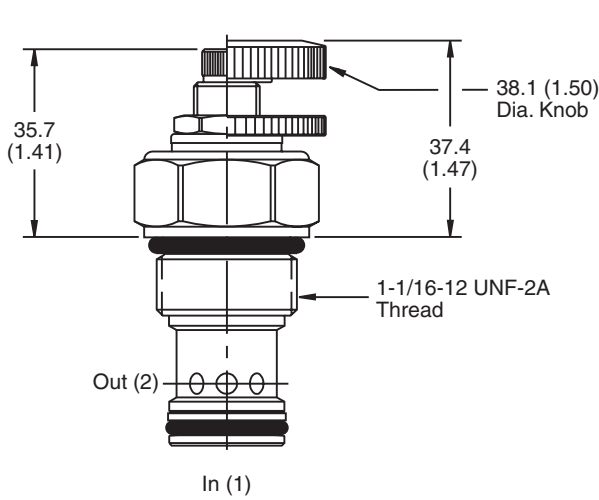

Screw/Knob Version

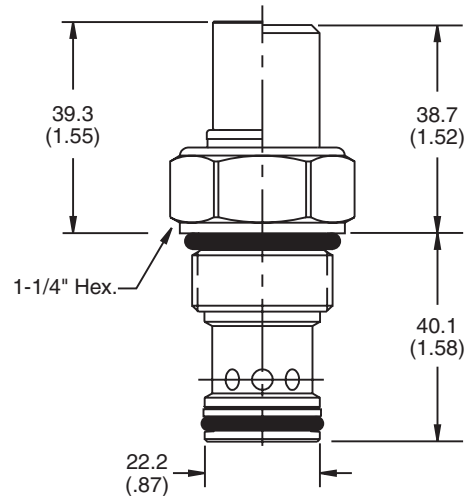

Fixed Cap/Tamper Resistant Version

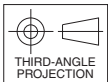

Ordering Information

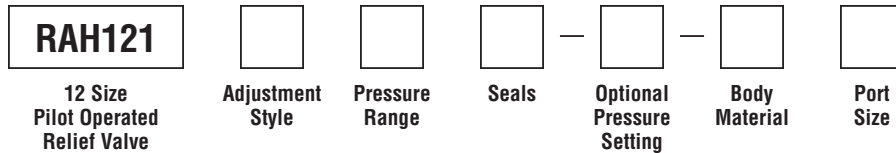

Code	Adjustment Style / Kit No.
F	Fixed style, preset at factory.
K	Knob Adjust (717784-15)
S	Screw Adjust
T	Tamper Resistant Cap (717785)

Code	Seals / Kit No.
Omit	Nitrile / (SK12-2)
V	Fluorocarbon / (SK12-2V)

Code	Body Material
Omit	Steel
A	Aluminum

Code	Pressure Range
10	6.9 - 69 Bar (100 - 1000 PSI) Standard Setting: 34.5 Bar (500 PSI) @ 11.3 LPM (3 GPM)
20	13.8 - 138 Bar (200 - 2000 PSI) Standard Setting: 69 Bar (1000 PSI) @ 11.3 LPM (3 GPM)
30	20.7 - 207 Bar (300 - 3000 PSI) Standard Setting: 103.5 Bar (1500 PSI) @ 11.3 LPM (3 GPM)
50	34.5 - 345 Bar (500 - 5000 PSI) Standard Setting: 172.4 Bar (2500 PSI) @ 11.3 LPM (3 GPM)

Optional Pressure Setting
Pressure \pm 10 i.e. 235 = 2350 PSI (Omit if standard setting is used) Setting Range: 100 to 5000 PSI All settings at 11.3 LPM (3 GPM)

Code	Port Size	Body Part No.
Omit	Cartridge Only	
12P	3/4" NPTF	(B12-2-*12P)
8T	SAE-8	(B12-2-*8T)
12T	SAE-12	(B12-2-*12T)

* Add "A" for aluminum, omit for steel.

Technical Information

- CV** Check Valves
- SH** Shuttle Valves
- LM** Load/Motor Controls
- FC** Flow Controls
- PC** Pressure Controls
- LE** Logic Elements
- DC** Directional Controls
- MV** Manual Valves
- SV** Solenoid Valves
- PV** Proportional Valves
- CE** Coils & Electronics
- BC** Bodies & Cavities
- TD** Technical Data

General Description

Pilot Operated Spool-Type Relief Valve. For additional information see Technical Tips on pages PC1-PC6.

Features

- Low override curve
- Ball-type pilot for added stability
- High accuracy - pilot operated design
- Hardened, precision ground parts for durability
- Compact size for reduced space requirements
- All external parts have yellow zinc dichromate. This coating is ideal for salt spray applications.

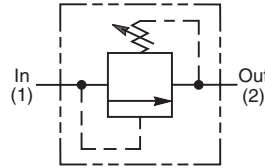
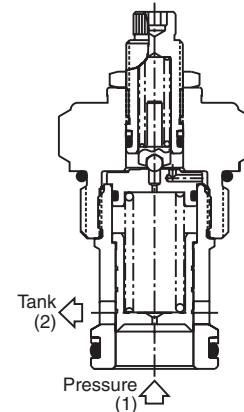

Specifications

Maximum Flow	302.8 LPM (80 GPM)
Maximum Inlet Pressure	380 Bar (5500 PSI)
Maximum Pressure Setting	350 Bar (5000 PSI)
Maximum Tank Pressure	350 Bar (5000 PSI)
Reseat Pressure	80% of crack pressure
Leakage at 150 SSU (32 cSt)	5 cc per 100 PSI (6.8 Bar) setting
Cartridge Material	All parts steel. All operating parts hardened steel.
Operating Temp. Range (Ambient)	-40°C to +93.3°C (Nitrile) (-40°F to +200°F) -31.7°C to +121.1°C (Fluorocarbon) (-25°F to +250°F)
Fluid Compatibility/ Viscosity	Mineral-based or synthetic with lubricating properties at viscosities of 45 to 2000 SSU (6 to 420 cSt)
Filtration	ISO Code 16/13, SAE Class 4 or better
Approx. Weight	0.9 kg (2.0 lbs.)
Cavity	C16-2 (See BC Section for more details)
Form Tool	Rougher None Finisher NFT16-2F

Performance Curve

Flow vs. Inlet Pressure

(Pressure rise through cartridge only)

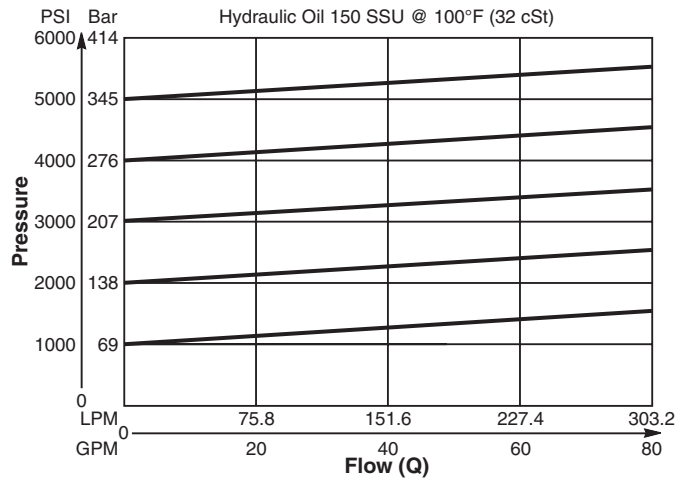

Dimensions Millimeters (Inches)

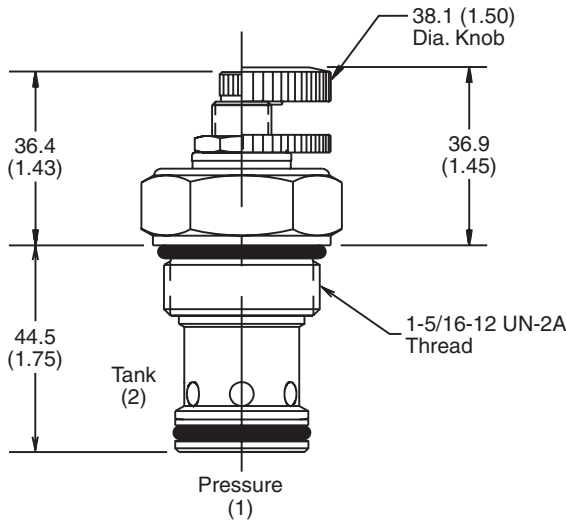

Screw/Knob Version

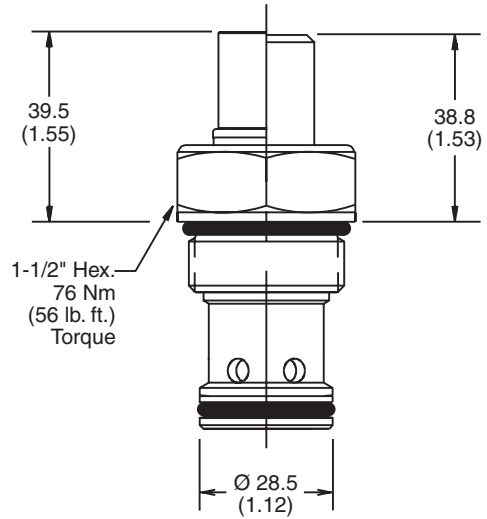

Fixed Cap/Tamper Resistant Version

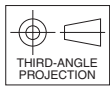

Ordering Information

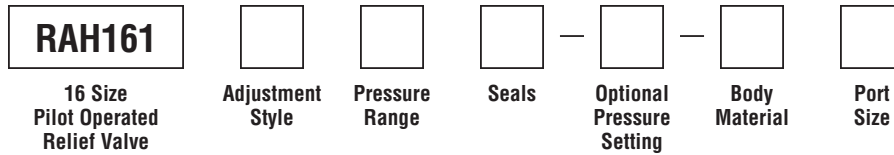

Code	Adjustment Style / Kit No.
F	Fixed style, preset at factory.
K	Knob Adjust (717784-15)
S	Screw Adjust
T	Tamper Resistant Cap (717785)

Code	Seals / Kit No.
Omit	Nitrile / (SK16-2)
V	Fluorocarbon / (SK16-2V)

Code	Body Material
Omit	Steel
A	Aluminum

Code	Pressure Range
10	6.9 - 69 Bar (100 - 1000 PSI) Standard Setting: 34.5 Bar (500 PSI) @ 37.5 LPM (10 GPM)
20	13.8 - 138 Bar (200 - 2000 PSI) Standard Setting: 69 Bar (1000 PSI) @ 37.5 LPM (10 GPM)
30	20.7 - 207 Bar (300 - 3000 PSI) Standard Setting: 103.5 Bar (1500 PSI) @ 37.5 LPM (10 GPM)
50	34.5 - 345 Bar (500 - 5000 PSI) Standard Setting: 172.4 Bar (2500 PSI) @ 37.5 LPM (10 GPM)

Optional Pressure Setting
Pressure \pm 10 i.e. 235 = 2350 PSI (Omit if standard setting is used) Setting Range: 100 to 5000 PSI All settings at 37.5 LPM (10 GPM)

Code	Port Size	Body Part No.
Omit	Cartridge Only	
12P	3/4" NPTF	(B16-2-*12P)
16P	1" NPTF	(B16-2-*16P)
8T	SAE-8	(B16-2-*8T)
12T	SAE-12	(B16-2-*12T)
16T	SAE-16	(B16-2-*16T)
12B	3/4" BSPG	(B16-2-12B)†
16B	1" BSPG	(B16-2-*16B)

* Add "A" for aluminum, omit for steel.
 † Steel body only.

Technical Information

- CV** Check Valves
- SH** Shuttle Valves
- LM** Load/Motor Controls
- FC** Flow Controls
- PC** Pressure Controls
- LE** Logic Elements
- DC** Directional Controls
- MV** Manual Valves
- SV** Solenoid Valves
- PV** Proportional Valves
- CE** Coils & Electronics
- BC** Bodies & Cavities
- TD** Technical Data

General Description

Pilot Operated, Spool-Type Relief Valve. For additional information see Technical Tips on pages PC1-PC6.

Features

- Very high flow capacity
- Minimal pressure variation with flow change
- Full tank line back pressure capability, ideal for crossline relief applications
- Integral 250 micron pilot flow filter
- Hardened working parts for maximum durability
- Adjustable and tamperproof versions available
- All external parts zinc plated

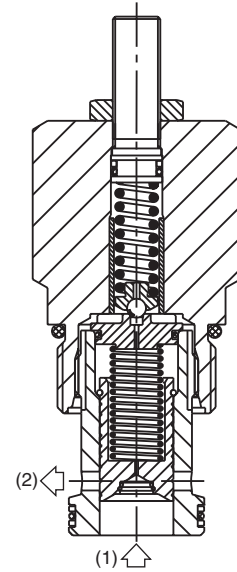
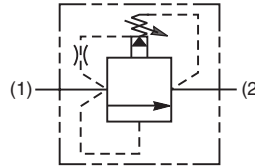
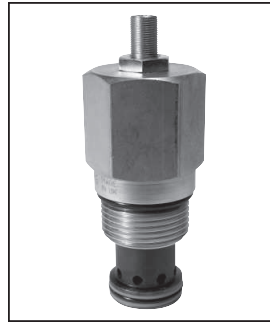

Specifications

Rated Flow	400 LPM (106 GPM)
Maximum Inlet Pressure	H - 10-210 Bar (145-3000 PSI) P - 10-420 Bar (145-6000 PSI)
Maximum Pressure Setting	420 Bar (6000 PSI)
Maximum Tank Pressure	420 Bar (6000 PSI)
Leakage at 150 SSU (32 cSt)	100 ml/min. @ 100 Bar (1450 PSI)
Cartridge Material	All parts steel. All operating parts hardened steel.
Operating Temp. Range/Seals	-40°C to +93.3°C (Nitrile) (-40°F to +200°F) -31.7°C to +121.1°C (Fluorocarbon) (-25°F to +250°F)
Fluid Compatibility/Viscosity	Mineral-based or synthetic with lubricating properties at viscosities of 45 to 2000 SSU (6 to 420 cSt)
Filtration	ISO Code 16/13, SAE Class 4 or better
Approx. Weight	0.57 kg (1.26 lbs.)
Cavity	C16-2 (See BC Section for more details)
Form Tool	Rougher None Finisher NFT16-2F

Performance Curve

(Pressure rise through cartridge only)

Flow vs. Inlet Pressure

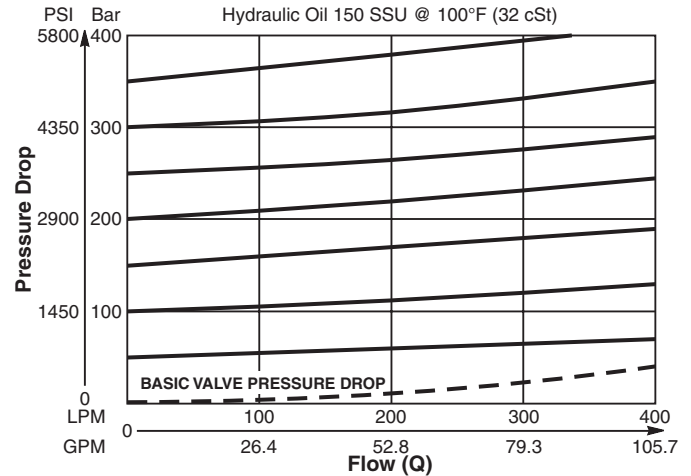

Dimensions Millimeters (Inches)

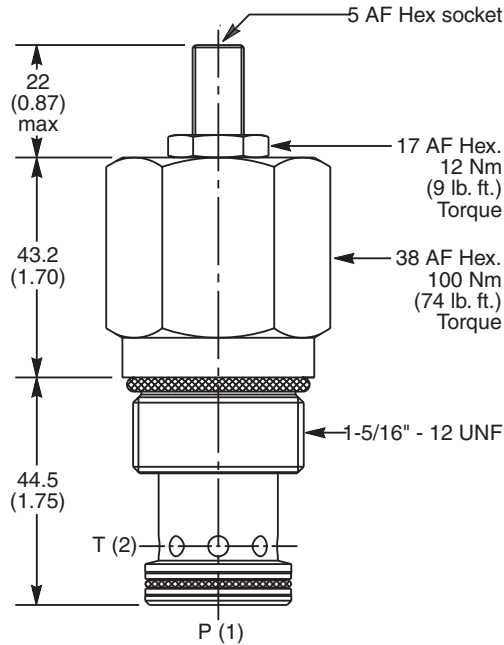

Ordering Information

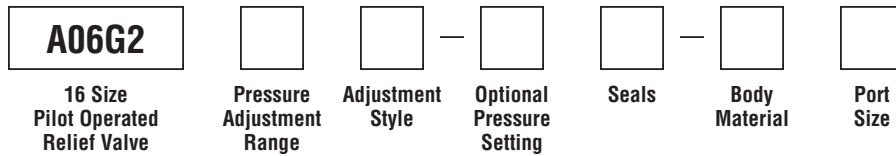

Code	Pressure Adjustment Range
H	10 - 210 Bar (145 - 3000 PSI)
P	10 - 420 Bar (145 - 6000 PSI)

Code	Seals / Kit No.
N	Nitrile, Buna-N (Std.) / (SK30507N-1)
V	Fluorocarbon / (SK30507V-1)

Code	Body Material
Omit	Steel
A	Aluminum

Code	Adjustment Style / Kit No.
Z	Screw Adjust (Std.)
W	Knob Adjust
T	Tamper Resistant Cap (TC1130)

Code	Port Size	Body Part No.
Omit	Cartridge Only	
12P	3/4" NPTF	(B16-2-*12P)
16P	1" NPTF	(B16-2-*16P)
8T	SAE-8	(B16-2-*8T)
12T	SAE-12	(B16-2-*12T)
16T	SAE-16	(B16-2-*16T)
12B	3/4" BSPG	(B16-2-12B)†
16B	1" BSPG	(B16-2-*16B)

Optional Pressure Setting	
Specify setting if required (Bar)	
A06G2H Standard Setting: 100 Bar (1450 PSI) @ 15 LPM (4.0 GPM)	
A06G2P Standard Setting: 200 Bar (2900 PSI) @ 15 LPM (4.0 GPM)	

* Add "A" for aluminum, omit for steel.
 † Steel body only.

Technical Information

CV Check Valves
SH Shuttle Valves
LM Load/Motor Controls
FC Flow Controls
PC Pressure Controls
LE Logic Elements
DC Directional Controls
MV Manual Valves
SV Solenoid Valves
PV Proportional Valves
CE Coils & Electronics
BC Bodies & Cavities
TD Technical Data

General Description

Pilot Operated Spool-Type Relief Valve. For additional information see Technical Tips on pages PC1-PC6.

Features

- Low override curve
- Ball-type pilot for added stability
- High accuracy - pilot operated design
- Hardened, precision ground parts for durability
- Compact size for reduced space requirements
- All external parts have yellow zinc dichromate. This coating is ideal for salt spray applications.

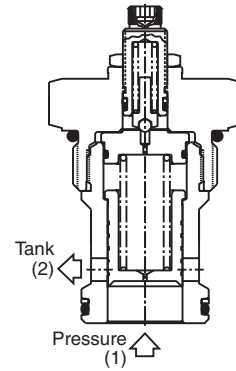
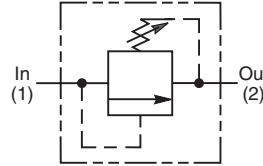
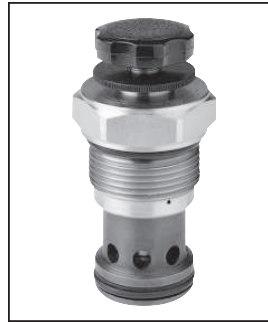

Specifications

Rated Flow	379 LPM (100 GPM)
Maximum Inlet Pressure	380 Bar (5500 PSI)
Maximum Pressure Setting	350 Bar (5000 PSI)
Maximum Tank Pressure	350 Bar (5000 PSI)
Reseat Pressure	80% of crack pressure
Leakage at 150 SSU (32 cSt)	5 cc per 100 PSI (6.8 Bar) setting
Cartridge Material	All parts steel. All operating parts hardened steel.
Operating Temp. Range/Seals	-40°C to +93.3°C (Nitrile) (-40°F to +200°F) -31.7°C to +121.1°C (Fluorocarbon) (-25°F to +250°F)
Fluid Compatibility/Viscosity	Mineral-based or synthetic with lubricating properties at viscosities of 45 to 2000 SSU (6 to 420 cSt)
Filtration	ISO Code 16/13, SAE Class 4 or better
Approx. Weight	0.9 kg (2.0 lbs.)
Cavity	C20-2 (See BC Section for more details)
Form Tool	Rougher None Finisher NFT20-2F

Performance Curve

Flow vs. Inlet Pressure

(Pressure rise through cartridge only)

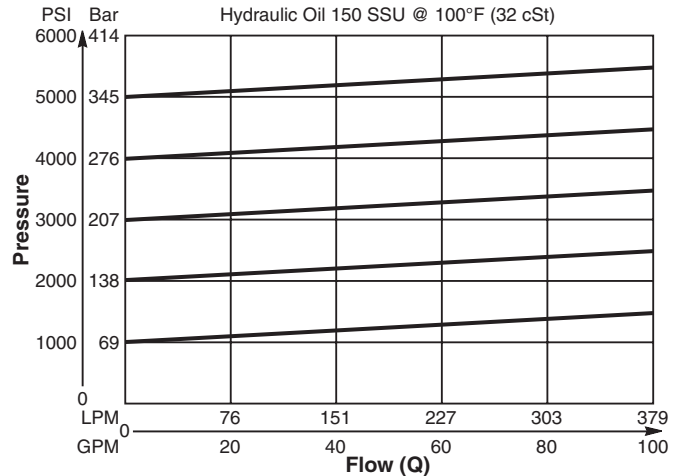

Dimensions Millimeters (Inches)

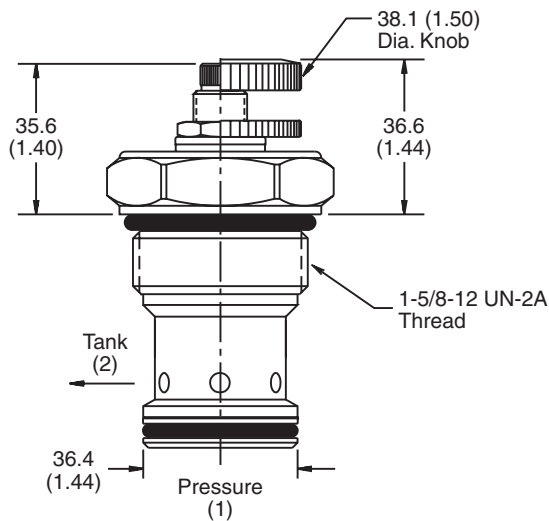

Screw/Knob Version

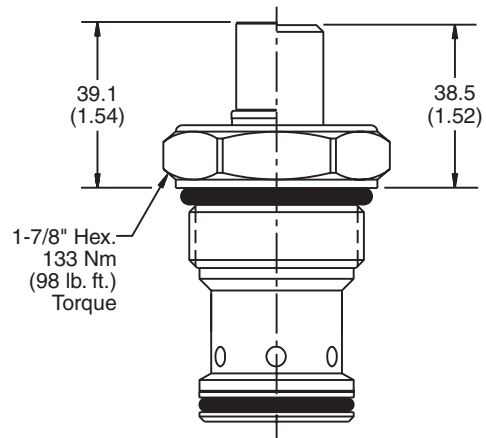

Fixed Cap/Tamper Resistant Version

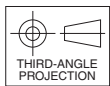

Ordering Information

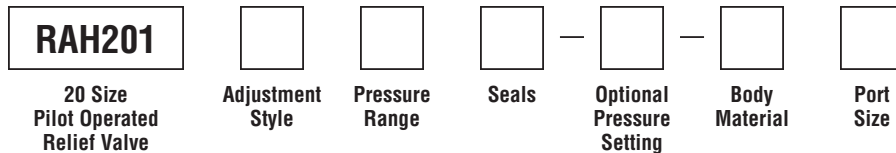

Code	Adjustment Style / Kit No.
F	Fixed style, preset at factory.
K	Knob Adjust (717784-15)
S	Screw Adjust
T	Tamper Resistant Cap (717785)

Code	Seals / Kit No.
Omit	Nitrile / (SK20-2)
V	Fluorocarbon / (SK20-2V)

Code	Body Material
Omit	Steel

Code	Pressure Range
10	6.9 - 69 Bar (100 - 1000 PSI) Standard Setting: 34.5 Bar (500 PSI) @ 37.5 LPM (10 GPM)
20	13.8 - 138 Bar (200 - 2000 PSI) Standard Setting: 69 Bar (1000 PSI) @ 37.5 LPM (10 GPM)
30	20.7 - 207 Bar (300 - 3000 PSI) Standard Setting: 103.5 Bar (1500 PSI) @ 37.5 LPM (10 GPM)
50	34.5 - 345 Bar (500 - 5000 PSI) Standard Setting: 172.4 Bar (2500 PSI) @ 37.5 LPM (10 GPM)

Optional Pressure Setting
Pressure \pm 10 i.e. 235 = 2350 PSI (Omit if standard setting is used) Setting Range: 100 to 5000 PSI All settings at 37.5 LPM (10 GPM)

Code	Port Size	Body Part No.
Omit	Cartridge Only	
20T	SAE-20	(B20-2-20T)
20B	1-1/4" BSPG	(B20-2-20B)

Technical Information

- CV** Check Valves
- SH** Shuttle Valves
- LM** Load/Motor Controls
- FC** Flow Controls
- PC** Pressure Controls
- LE** Logic Elements
- DC** Directional Controls
- MV** Manual Valves
- SV** Solenoid Valves
- PV** Proportional Valves
- CE** Coils & Electronics
- BC** Bodies & Cavities
- TD** Technical Data

General Description

Kick-Down, Pilot Operated Relief Valve. For additional information see Technical Tips on pages PC1-PC6.

Features

- High flow capacity
- Integral 250 micron pilot flow filter
- Hardened working parts for maximum durability
- Adjustable and tamper resistant versions available
- All external parts zinc plated

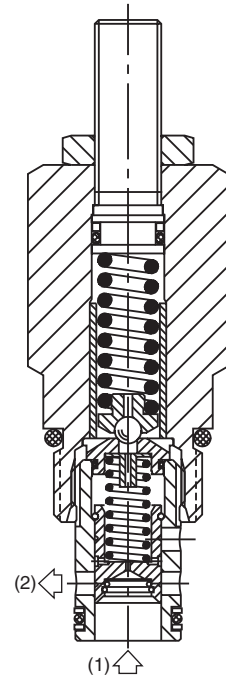
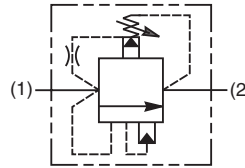
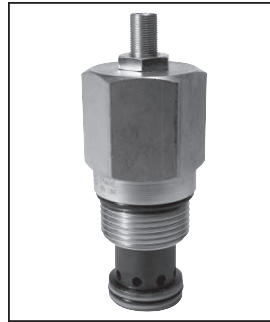

Specifications

Rated Flow	160 LPM (42 GPM)
Maximum Inlet Pressure	420 Bar (6000 PSI)
Maximum Pressure Setting	H - 10-210 Bar (145-3000 PSI) P - 10-420 Bar (144-6000 PSI)
Maximum Tank Pressure	420 Bar (6000 PSI)
Sensitivity: Pressure/Turn	H - 30 Bar (435 PSI) P - 55 Bar (800 PSI)
Leakage at 150 SSU (32 cSt)	25 ml/min. @ 50 Bar (725 PSI)
Cartridge Material	All parts steel. All operating parts hardened steel.
Operating Temp. Range/Seals	-40°C to +93.3°C (Nitrile) (-40°F to +200°F) -31.7°C to +121.1°C (Fluorocarbon) (-25°F to +250°F)
Fluid Compatibility/Viscosity	Mineral-based or synthetic with lubricating properties at viscosities of 45 to 2000 SSU (6 to 420 cSt)
Filtration	ISO Code 16/13, SAE Class 4 or better
Approx. Weight	0.29 kg (0.64 lbs.)
Cavity	C10-2 (See BC Section for more details)
Form Tool	Rougher None Finisher

Performance Curve

(Pressure rise through cartridge only)

Pressure Drop vs. Flow

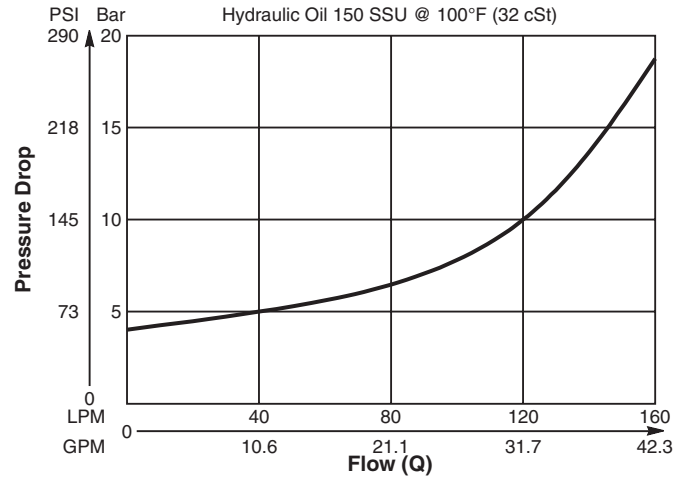

Application Note

Valve unloads completely when setting is reached and resets when fluid supply is removed.

Dimensions Millimeters (Inches)

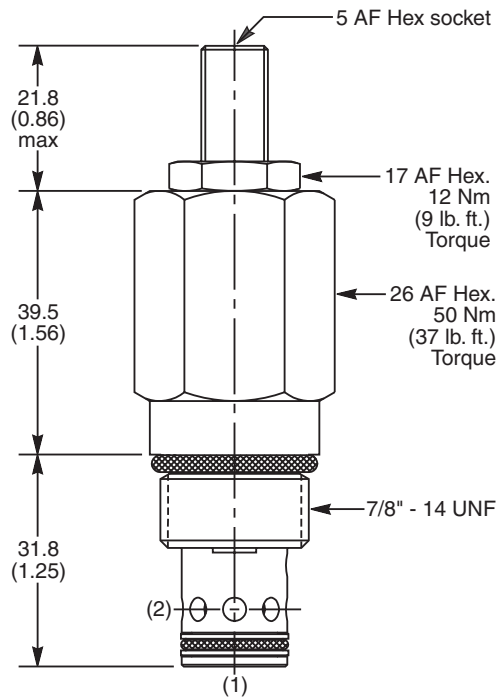

Ordering Information

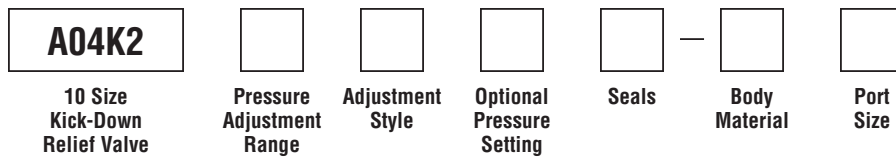

Code	Pressure Adjustment Range
H	10 - 210 Bar (145 - 3000 PSI)
P	10 - 420 Bar (145 - 6000 PSI)

Code	Seals / Kit No.
N	Nitrile, Buna-N (Std.) / (SK30503N-1)
V	Fluorocarbon / (SK30503V-1)

Code	Body Material
Omit	Steel
A	Aluminum

Code	Adjustment Style / Kit No.
Z	Screw Adjust (Std.)
W	Knob Adjust
T	Tamper Resistant Cap (TC1130)

Code	Port Size	Body Part No.
Omit	Cartridge Only	
4P	1/4" NPTF	(B10-2-*4P)
6P	3/8" NPTF	(B10-2-*6P)
8P	1/2" NPTF	(B10-2-*8P)
6T	SAE-6	(B10-2-*6T)
8T	SAE-8	(B10-2-*8T)
T8T	SAE-8	(B10-2-T8T)†
6B	3/8" BSPG	(B10-2-6B)†

Optional Pressure Setting	
Specify setting if required (Bar)	
A04K2H	Standard Setting: 100 Bar (1450 PSI)
A04K2P	Standard Setting: 200 Bar (2900 PSI)

* Add "A" for aluminum, omit for steel.
 † Steel body only.

Technical Information

- CV** Check Valves
- SH** Shuttle Valves
- LM** Load/Motor Controls
- FC** Flow Controls
- PC** Pressure Controls
- LE** Logic Elements
- DC** Directional Controls
- MV** Manual Valves
- SV** Solenoid Valves
- PV** Proportional Valves
- CE** Coils & Electronics
- BC** Bodies & Cavities
- TD** Technical Data

General Description

Solenoid Operated Unloading Relief Valve. For additional information see Technical Tips on pages PV1-PV6.

Features

- Two functions in one valve, unloading and relieving
- Factory set relief pressure or adjustable option
- Integral 250 micron pilot flow filter
- Coil: Waterproof, hermetically sealed, requires no O’Rings; Symmetrical coil can be reversed without affecting performance.

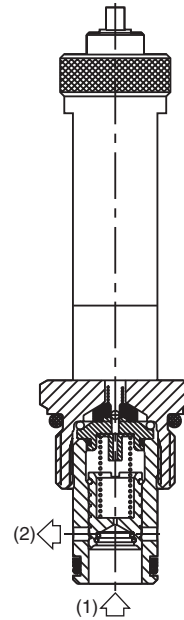
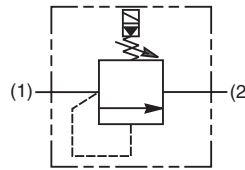

Specifications

Rated Flow (At 70 PSI ΔP)	60 LPM (16 GPM)
Max. Pressure	6.9 - 276 Bar (100 - 4000 PSI)
Reseat Pressure 200 Hz PWM	90% of Cracking Pressure
Max. Tank Pressure	70 Bar (1000 PSI)
Cartridge Material	All parts steel. All operating parts hardened steel.
Operating Temp. Range/Seals	-40°C to +93.3°C (Nitrile) (-40°F to +200°F) -31.7°C to +121.1°C (Fluorocarbon) (-25°F to +250°F)
Fluid Compatibility/ Viscosity	Mineral-based or synthetic with lubricating properties at viscosities of 45 to 2000 SSU (6 to 420 cSt)
Filtration	ISO Code 16/13, SAE Class 4 or better
Approx. Weight	.45 kg (.98 lbs.)
Cavity	C10-2 (See BC Section for more details)

Performance Curves

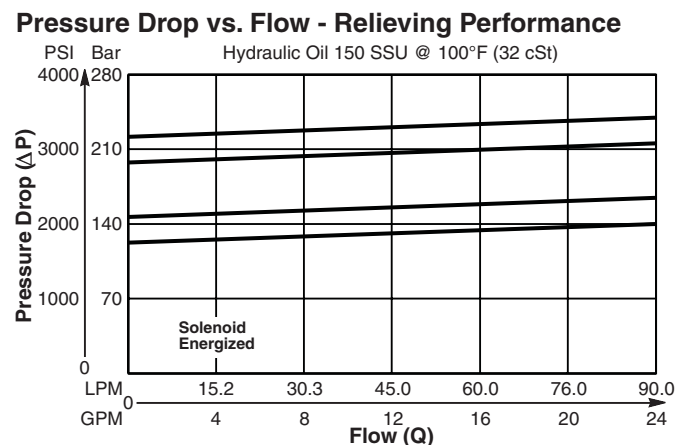
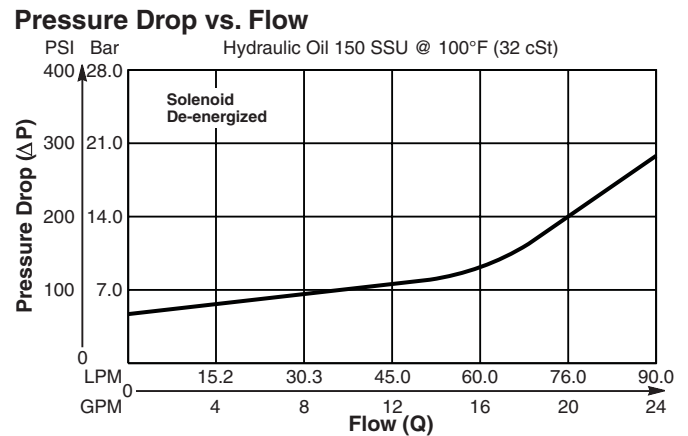

Dimensions Millimeters (Inches)

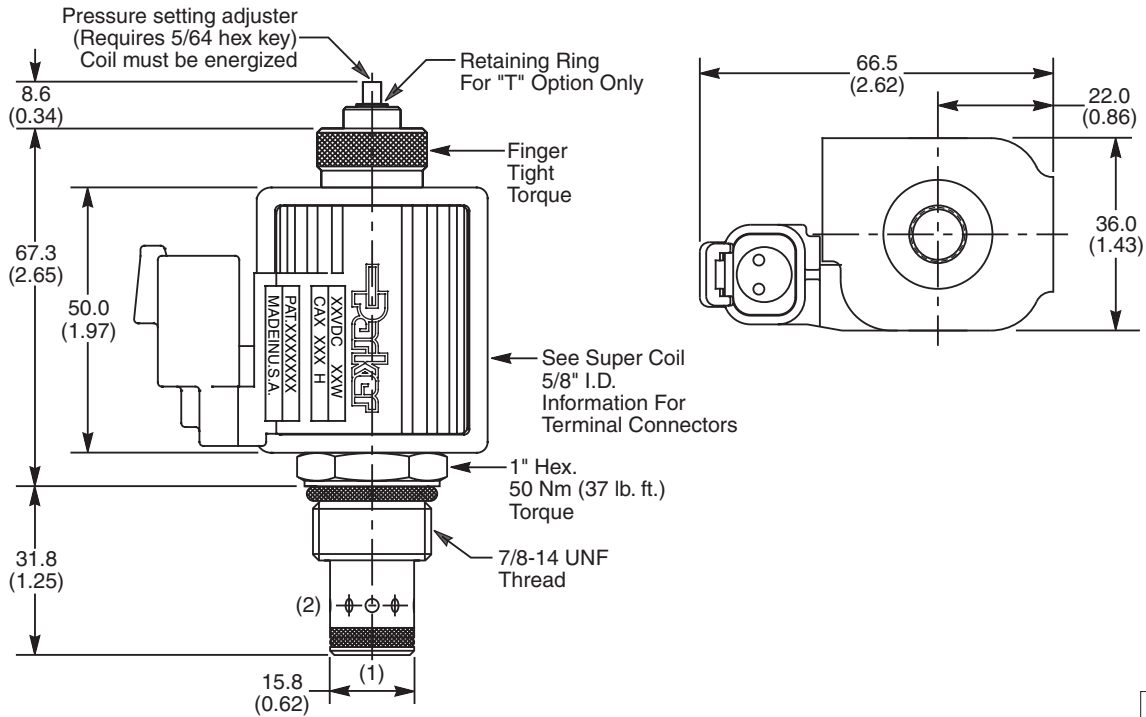

Ordering Information

AS04G2

10 Size Proportional Relief Valve **Adjustment Option** **Relief Setting** **Seals** **Coil Type** **Coil Voltage** **Coil Termination** **Body Material** **Port Size**

Code	Adjustment Options
T	Tamper Proof
Z	Push and Turn

Code	Seals / Kit. No.
N	Nitrile / Buna-N (Std.) (SK30006N-1)
V	Fluorocarbon / (SK30006V-1)

Code	Coil Voltage
Omit	Without Coil
D012	12 VDC
D024	24 VDC

Code	Body Material
Omit	Steel
A	Aluminum

Code	Relief Setting
Omit	124 Bar (1800 PSI) Standard
14	140 Bar (2000 PSI)
20	200 Bar (2900 PSI)
22	220 Bar (3200 PSI)
27	276 Bar (4000 PSI)

Code	Coil Type
Omit	Without Coil
SP	Super Coil - 28 Watts

Code	Coil Termination
Omit	Without Coil
D	DIN Plug Face
A	Amp Jr. Timer*
L	Dual Lead Wire*
LS	Sealed Lead Wire*
H	Molded Deutsch*

Code	Port Size	Body Part No.
Omit	Cartridge Only	
4P	1/4" NPTF	(B10-2-*4P)
6P	3/8" NPTF	(B10-2-*6P)
8P	1/2" NPTF	(B10-2-*8P)
6T	SAE-6	(B10-2-*6T)
8T	SAE-8	(B10-2-*8T)
T8T	SAE-8	(B10-2-T8T)†
6B	3/8" BSPG	(B10-2-*6B)

See Super Coil 5/8" I.D.
*DC Only

* Add "A" for aluminum, omit for steel.
† Steel body only.

- CV Check Valves
- SH Shuttle Valves
- LM Load/Motor Controls
- FC Flow Controls
- PC Pressure Controls
- LE Logic Elements
- DC Directional Controls
- MV Manual Valves
- SV Solenoid Valves
- PV Proportional Valves
- CE Coils & Electronics
- BC Bodies & Cavities
- TD Technical Data

Technical Information

- CV** Check Valves
- SH** Shuttle Valves
- LM** Load/Motor Controls
- FC** Flow Controls
- PC** Pressure Controls
- LE** Logic Elements
- DC** Directional Controls
- MV** Manual Valves
- SV** Solenoid Valves
- PV** Proportional Valves
- CE** Coils & Electronics
- BC** Bodies & Cavities
- TD** Technical Data

General Description

Ventable Pilot Operated Spool-Type Relief Valve. This valve controls pressure via the internal spring chamber or via an external vent line. For addition information see Technical Tips on pages PC1-PC6.

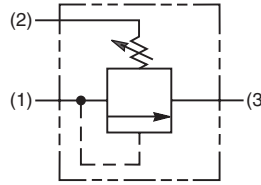
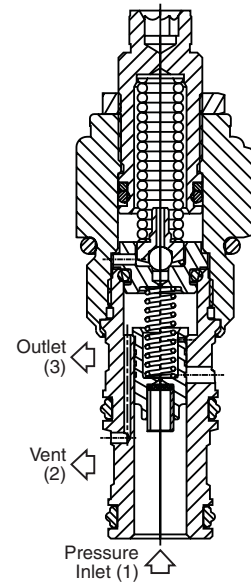

Features

- Low override curve
- Ball-type pilot for added stability
- High accuracy - pilot operated design
- Hardened, precision ground parts for durability
- Compact size for reduced space requirements
- All external parts have yellow zinc dichromate. This coating is ideal for salt spray applications.

Specifications

Rated Flow	68 LPM (18 GPM)
Maximum Inlet Pressure	380 Bar (5500 PSI)
Maximum Pressure Setting	350 Bar (5000 PSI)
Maximum Tank Pressure	350 Bar (5000 PSI)
Reseat Pressure	80% of crack pressure
Leakage at 150 SSU (32 cSt)	5 cc per 100 PSI (6.8 Bar) setting
Cartridge Material	All parts steel. All operating parts hardened steel.
Operating Temp. Range/Seals	-45°C to +93.3°C ("D"-Ring) (-50°F to +200°F) -31.7°C to +121.1°C (Fluorocarbon) (-25°F to +250°F)
Fluid Compatibility/Viscosity	Mineral-based or synthetic with lubricating properties at viscosities of 45 to 2000 SSU (6 to 420 cSt)
Filtration	ISO Code 16/13, SAE Class 4 or better
Approx. Weight	.23 kg (.50 lbs.)
Cavity	C10-3 (See BC Section for more details)
Form Tool	Rougher NFT10-3R Finisher NFT10-3F

Performance Curves

Flow vs. Inlet Pressure

(Pressure rise through cartridge only)

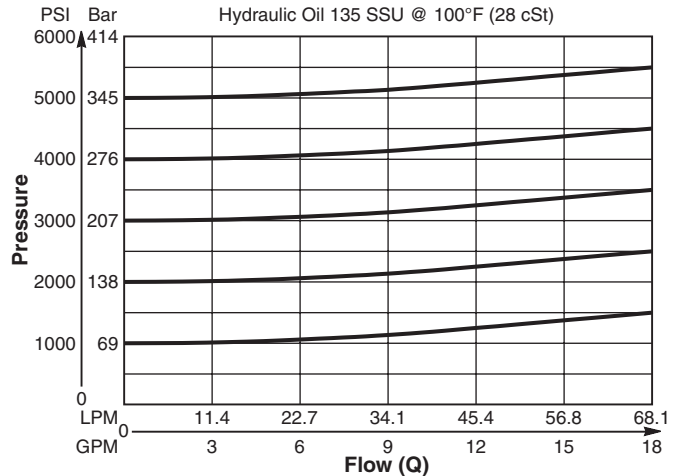

Dimensions Millimeters (Inches)

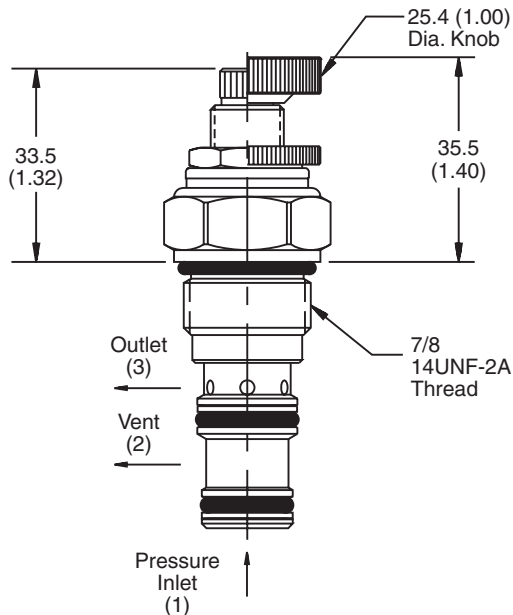

Screw/Knob Version

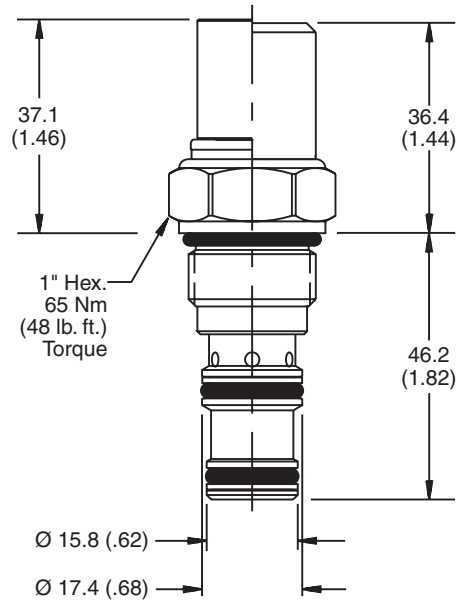

Fixed Cap/Tamper Resistant Version

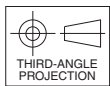

Ordering Information

RAH101V — —

10 Size **Adjustment** **Pressure** **Seals** **Optional** **Body** **Port**
Ventable Pilot **Style** **Range** **Pressure** **Material** **Size**
Operated Relief
Valve

Code	Adjustment Style / Kit No.
F	Fixed style, preset at factory.
K	Knob Adjust (717784-10)
S	Screw Adjust
T	Tamper Resistant Cap (718083)

Code	Seals / Kit No.
Omit	"D"-Ring / (SK10-3)
N	Nitrile / (SK10-3N)
V	Fluorocarbon / (SK10-3V)

Code	Body Material
Omit	Steel
A	Aluminum

Code	Pressure Range
10	6.9 - 69 Bar (100 - 1000 PSI) Standard Setting: 34.5 Bar (500 PSI) @ 11.3 LPM (3 GPM)
20	13.8 - 138 Bar (200 - 2000 PSI) Standard Setting: 69 Bar (1000 PSI) @ 11.3 LPM (3 GPM)
30	20.7 - 207 Bar (300 - 3000 PSI) Standard Setting: 103.5 Bar (1500 PSI) @ 11.3 LPM (3 GPM)
50	34.5 - 345 Bar (500 - 5000 PSI) Standard Setting: 172.4 Bar (2500 PSI) @ 11.3 LPM (3 GPM)

Optional Pressure Setting
Pressure ÷ 10 i.e. 235 = 2350 PSI (Omit if standard setting is used) Setting Range: 100 to 5000 PSI All settings at 11.3 LPM (3 GPM)

Code	Port Size	Body Part No.
Omit	Cartridge Only	
4P	1/4" NPTF	(B10-3-*4P)
6P	3/8" NPTF	(B10-3-*6P)
8P	1/2" NPTF	(B10-3-*8P)
6T	SAE-6	(B10-3-*6T)
8T	SAE-8	(B10-3-*8T)
4B	1/4" BSPG	(B10-3-4B)†
6B	3/8" BSPG	(B10-3-6B)†
8B	1/2" BSPG	(B10-3-*8B)

* Add "A" for aluminum, omit for steel.
 † Steel body only.

Technical Information

- CV** Check Valves
- SH** Shuttle Valves
- LM** Load/Motor Controls
- FC** Flow Controls
- PC** Pressure Controls
- LE** Logic Elements
- DC** Directional Controls
- MV** Manual Valves
- SV** Solenoid Valves
- PV** Proportional Valves
- CE** Coils & Electronics
- BC** Bodies & Cavities
- TD** Technical Data

General Description

Pilot Operated, Spool-Type, Ventable Relief Valve. For additional information see Technical Tips on pages PC1-PC6.

Features

- High flow capacity
- Full tank line back pressure capability
- Excellent flow pressure characteristics for consistent pressure setting
- Ideal for pump relief and remote control or unloading via vent (port 3)
- Integral 250 micron pilot flow filter
- Hardened working parts for maximum durability
- Adjustable and tamperproof versions available
- All external parts zinc plated

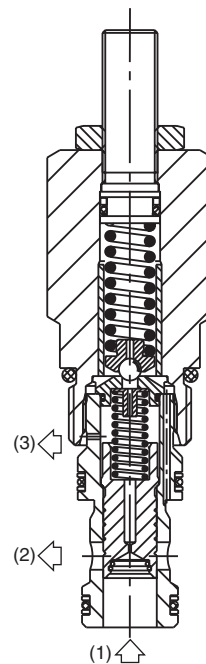
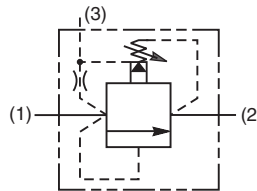
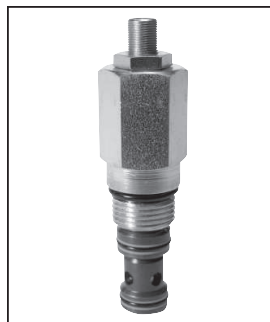

Specifications

Rated Flow	190 LPM (50 GPM)
Maximum Inlet Pressure	H - 10-210 Bar (145-3000 PSI) P - 10-420 Bar (145-6000 PSI)
Maximum Pressure Setting	420 Bar (6000 PSI)
Maximum Tank Pressure	420 Bar (6000 PSI)
Leakage at 150 SSU (32 cSt)	25 ml/min. @ 100 Bar (1450 PSI)
Cartridge Material	All parts steel. All operating parts hardened steel.
Operating Temp. Range/Seals	-40°C to +93.3°C (Nitrile) (-40°F to +200°F) -31.7°C to +121.1°C (Fluorocarbon) (-25°F to +250°F)
Fluid Compatibility/Viscosity	Mineral-based or synthetic with lubricating properties at viscosities of 45 to 2000 SSU (6 to 420 cSt)
Filtration	ISO Code 16/13, SAE Class 4 or better
Approx. Weight	0.25 kg (0.55 lbs.)
Cavity	C10-3S (See BC Section for more details)
Form Tool	Rougher None Finisher

Performance Curves

(Pressure rise through cartridge only)

Flow vs. Inlet Pressure 1 to 2

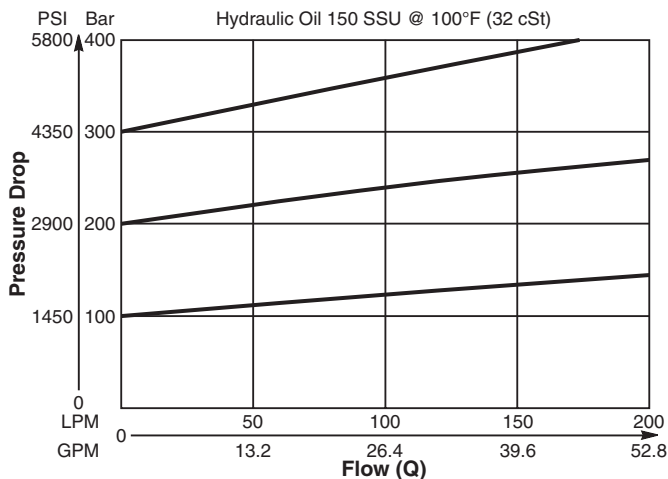

Vented Open Pressure Drop 1 to 2

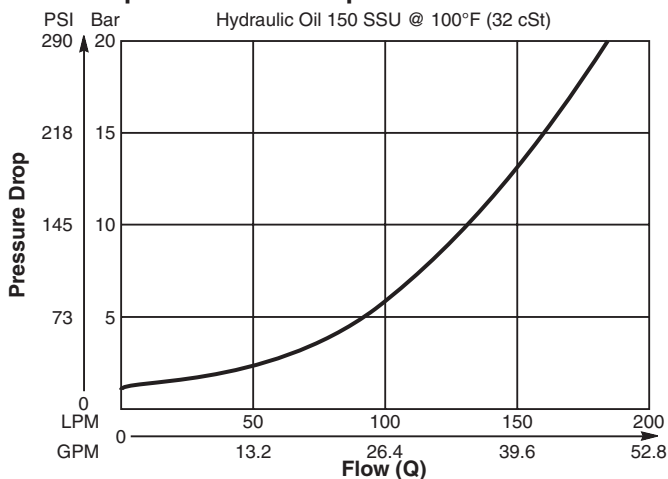

Dimensions Millimeters (Inches)

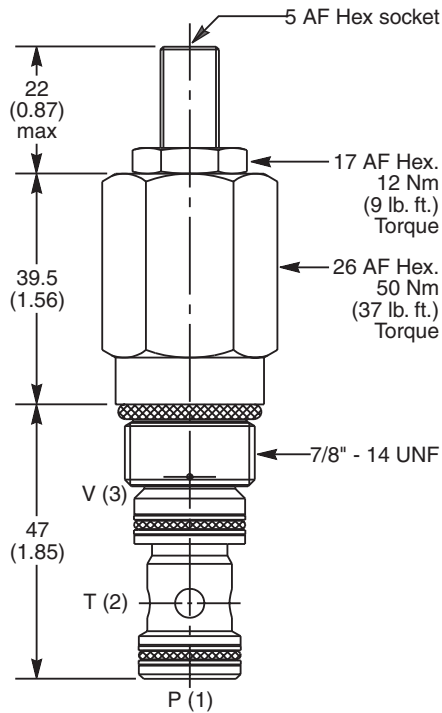

Ordering Information

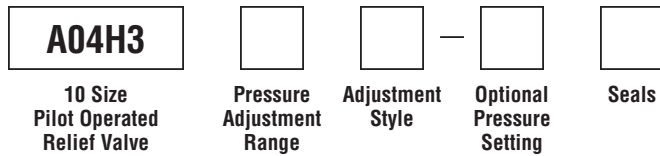

Code	Pressure Adjustment Range
H	10 - 210 Bar (145 - 3000 PSI)
P	10 - 420 Bar (145 - 6000 PSI)

Optional Pressure Setting	
Specify setting if required (Bar)	
A04H3H Standard Setting: 100 Bar (1450 PSI) @ 15 LPM (4.0 GPM)	
A04H3P Standard Setting: 200 Bar (2900 PSI) @ 15 LPM (4.0 GPM)	

Code	Adjustment Style / Kit No.
Z	Screw Adjust (Std.)
W	Knob Adjust
T	Tamper Resistant Cap (TC1130)

Code	Seals / Kit No.
N	Nitrile, Buna-N (Std.) / (SK30504N-1)
V	Fluorocarbon / (SK30504V-1)

Order Bodies Separately



Code	Porting
710	5/8" SAE (main) 3/8" SAE (aux)
711	3/4" BSP (main) 1/4" BSP (aux)

Code	Body Material
A	Aluminum
S	Steel

- CV**
Check Valves
- SH**
Shuttle Valves
- LM**
Load/Motor Controls
- FC**
Flow Controls
- PC**
Pressure Controls
- LE**
Logic Elements
- DC**
Directional Controls
- MV**
Manual Valves
- SV**
Solenoid Valves
- PV**
Proportional Valves
- CE**
Coils & Electronics
- BC**
Bodies & Cavities
- TD**
Technical Data

Technical Information

- CV** Check Valves
- SH** Shuttle Valves
- LM** Load/Motor Controls
- FC** Flow Controls
- PC** Pressure Controls
- LE** Logic Elements
- DC** Directional Controls
- MV** Manual Valves
- SV** Solenoid Valves
- PV** Proportional Valves
- CE** Coils & Electronics
- BC** Bodies & Cavities
- TD** Technical Data

General Description

Pilot Operated, Spool-Type, Ventable Relief Valve. For additional information see Technical Tips on pages PC1-PC6.

Features

- High flow capacity
- Full tank line back pressure
- Excellent pressure flow characteristics
- Ideal for pump relief and remote control or unloading via vent (port 3)
- Integral 250 micron pilot flow filter
- Hardened working parts for maximum durability
- Adjustable and tamperproof versions available
- All external parts zinc plated

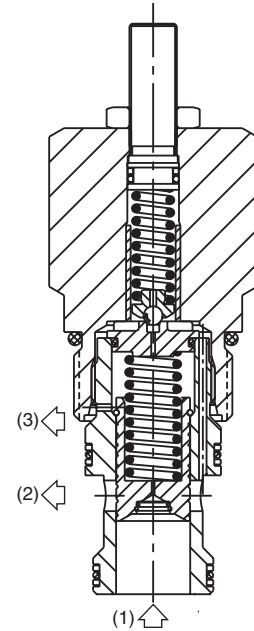
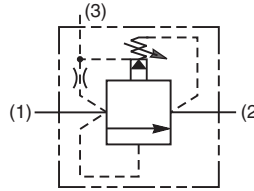
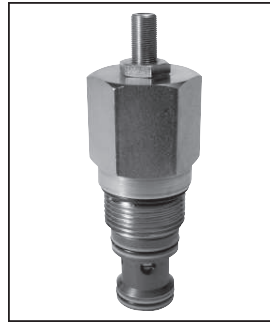

Specifications

Rated Flow	400 LPM (106 GPM)
Maximum Inlet Pressure	H - 10-210 Bar (145-3000 PSI) P - 10-420 Bar (145-6000 PSI)
Maximum Pressure Setting	420 Bar (6000 PSI)
Maximum Tank Pressure	420 Bar (6000 PSI)
Leakage at 150 SSU (32 cSt)	100ml/min. @ 100 Bar (1450 PSI)
Cartridge Material	All parts steel. All operating parts hardened steel.
Operating Temp. Range/Seals	-40°C to +93.3°C (Nitrile) (-40°F to +200°F) -31.7°C to +121.1°C (Fluorocarbon) (-25°F to +250°F)
Fluid Compatibility/Viscosity	Mineral-based or synthetic with lubricating properties at viscosities of 45 to 2000 SSU (6 to 420 cSt)
Filtration	ISO Code 16/13, SAE Class 4 or better
Approx. Weight	0.58 kg (1.28 lbs.)
Cavity	C16-3S (See BC Section for more details)
Form Tool	Rougher None Finisher

Performance Curves

(Pressure rise through cartridge only)

Flow vs. Inlet Pressure 1 to 2

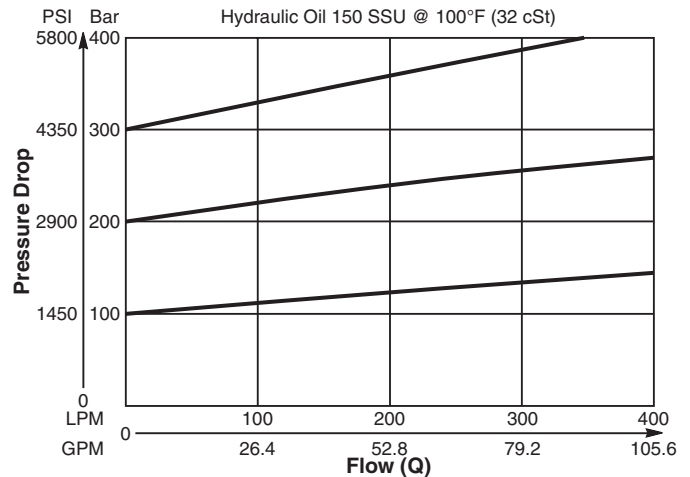

Vented Open Pressure Drop 1 to 2

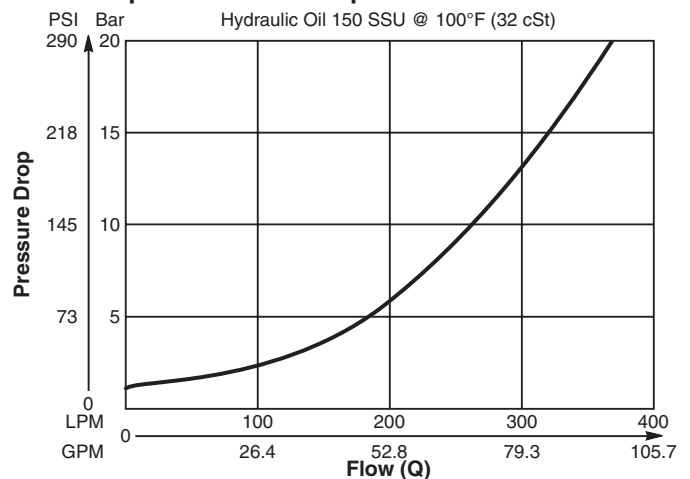

Dimensions Millimeters (Inches)

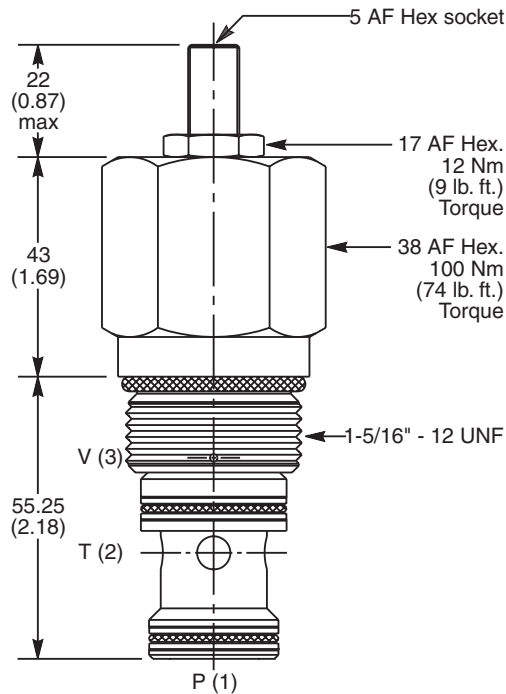

Ordering Information

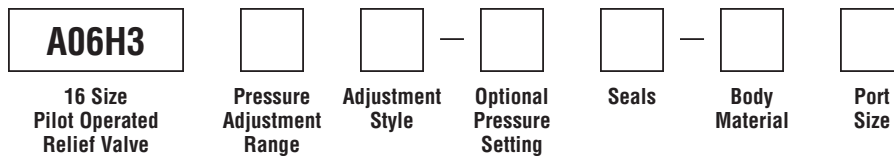

Code	Pressure Adjustment Range
H	10 - 210 Bar (145 - 3000 PSI)
P	10 - 420 Bar (145 - 6000 PSI)

Optional Pressure Setting	
Specify setting if required (Bar)	
A06H3H Standard Setting: 100 Bar (1450 PSI) @ 15 LPM (4.0 GPM)	
A06H3P Standard Setting: 200 Bar (2900 PSI) @ 15 LPM (4.0 GPM)	

Code	Body Material
Omit	Steel
A	Aluminum

Code	Adjustment Style / Kit No.
Z	Screw Adjust (Std.)
W	Knob Adjust
T	Tamper Resistant Cap (TC1130)

Code	Seals / Kit No.
N	Nitrile, Buna-N (Std.) / (SK30508N-1)
V	Fluorocarbon / (SK30508V-1)

Code	Port Size	Body Part No.
Omit	Cartridge Only	
16T	SAE-16	(B16-3S-*16T)
16B	1" BSPG	(B16-3S-*16B)

* Add "A" for aluminum, omit for steel.

Technical Information

- CV** Check Valves
- SH** Shuttle Valves
- LM** Load/Motor Controls
- FC** Flow Controls
- PC** Pressure Controls
- LE** Logic Elements
- DC** Directional Controls
- MV** Manual Valves
- SV** Solenoid Valves
- PV** Proportional Valves
- CE** Coils & Electronics
- BC** Bodies & Cavities
- TD** Technical Data

General Description

Dual Cross-Over Relief Valve in a single cartridge. For additional information see Technical Tips on pages PC1-PC6.

Features

- Fast response
- Compact size for reduced space requirements
- Low leakage design
- Single cartridge reduces plumbing, component and manifold costs

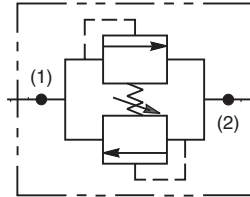
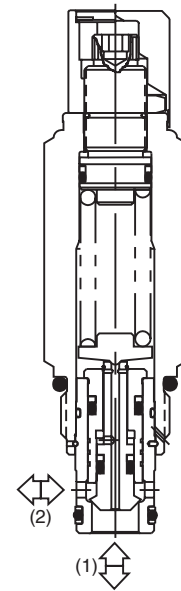
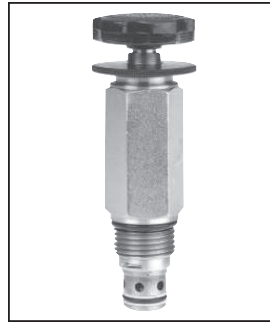

Specifications

Flow Rate	60.6 LPM (16 GPM)
Maximum Inlet Pressure	245 Bar (3500 PSI)
Maximum Pressure Setting	210 Bar (3000 PSI)
Reseat Pressure	80% of crack pressure
Leakage at 150 SSU (32 cSt)	10 drops/min. (.66 cc/min.) @ 75% of crack pressure
Cartridge Material	All parts steel. All operating parts hardened steel.
Operating Temp. Range (Ambient)	-40°C to +93.3°C (Nitrile) (-40°F to +200°F) -31.7°C to +121.1°C (Fluorocarbon) (-25°F to +250°F)
Filtration	ISO Code 16/13, SAE Class 4 or better
Fluids	Mineral-based or synthetic with lubricating properties at viscosities of 45 to 2000 SSU (6 to 420 cSt)
Approx. Weight	.26 kg (.58 lbs.)
Cavity	C10-2
Form Tool	Rougher None Finisher NFT10-2F

Performance Curve

Flow vs. Inlet Pressure
(Pressure rise through cartridge only)

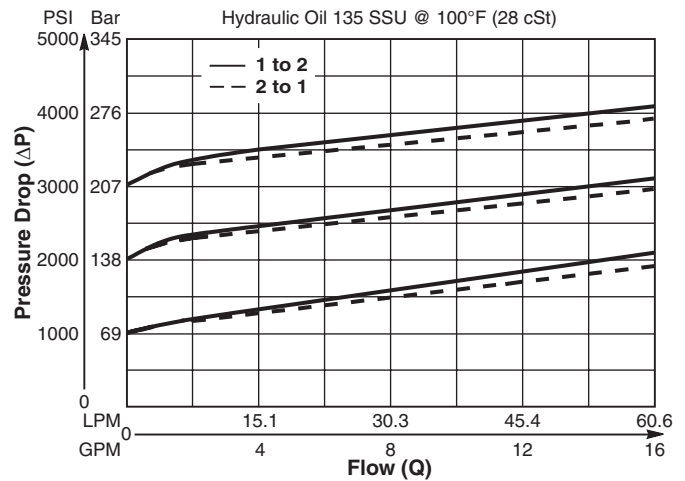

Dimensions Millimeters (Inches)

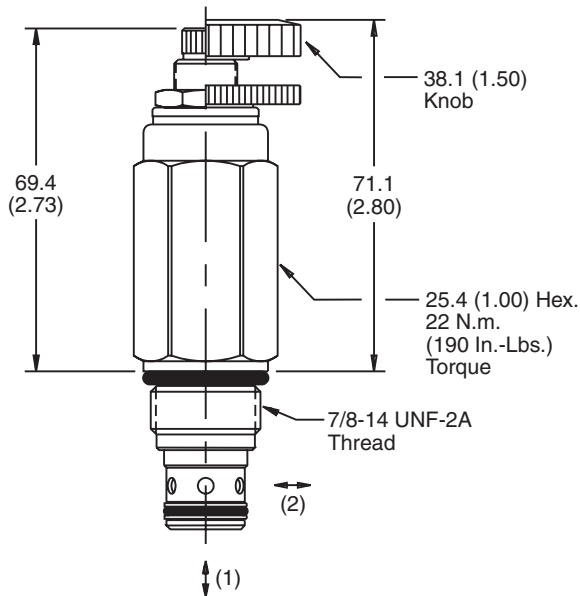

Screw/Knob Version

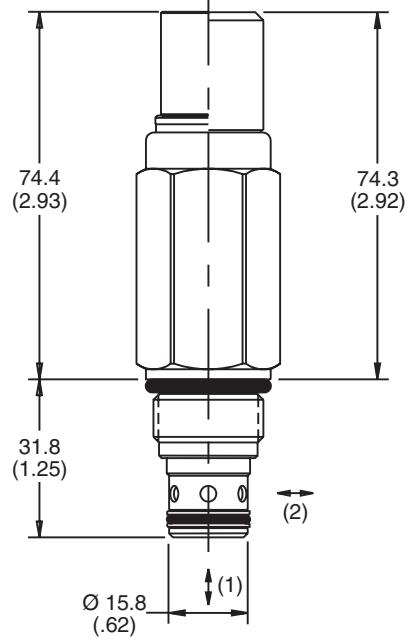

Fixed Cap/Tamper Resistant Version

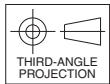

Ordering Information

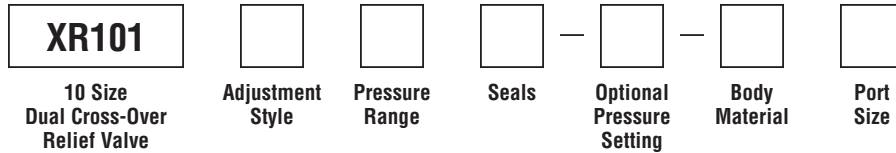

Code	Adjustment Style / Kit No.
F	Fixed style, preset at factory.
K	Knob Adjust (717784-15)
S	Screw Adjust
T	Tamper Resistant Cap (717785)

Code	Seals / Kit No.
Omit	Nitrile / (SK10-2N)
V	Fluorocarbon / (SK10-2V)

Code	Body Material
Omit	Steel
A	Aluminum

Code	Pressure Range
20	6.9 - 138 Bar (100 - 2000 PSI) Standard Setting: 69 Bar (1000 PSI) @ 11.3 LPM (3 GPM)
30	103 - 207 Bar (1500 - 3000 PSI) Standard Setting: 172 Bar (2500 PSI) @ 11.3 LPM (3 GPM)

Optional Pressure Setting
Pressure \pm 10 i.e. 235 = 2350 PSI (Omit if standard setting is used) Setting Range: 100 to 3000 PSI All settings at 11.3 LPM (3 GPM)

Code	Port Size	Body Part No.
Omit	Cartridge Only	
8P	1/2" NPTF	(B10-2-*8P)
6T	SAE-6	(B10-2-*6T)
8T	SAE-8	(B10-2-*8T)

* Add "A" for aluminum, omit for steel.

Technical Information

- CV** Check Valves
- SH** Shuttle Valves
- LM** Load/Motor Controls
- FC** Flow Controls
- PC** Pressure Controls
- LE** Logic Elements
- DC** Directional Controls
- MV** Manual Valves
- SV** Solenoid Valves
- PV** Proportional Valves
- CE** Coils & Electronics
- BC** Bodies & Cavities
- TD** Technical Data

General Description

Direct Acting, Dual Poppet-Type, Cross-over Relief Valve. For additional information see Technical Tips on pages PC1-PC6.

Features

- Compact space saving design
- Cost effective - only requires one cavity
- Poppet-type construction for lower leakage
- Full 350 Bar, 5000 PSI pressure capability
- High flow capability for the size of valve
- Minimal pressure variation with flow change
- Hardened working parts for maximum durability
- Adjustable and tamperproof versions available
- Available as CE marked valve in compliance with Pressure Equipment Directive
- All external parts zinc plated

Specifications

Rated Flow	120 LPM (32 GPM)
Maximum Inlet Pressure	H - 5-210 Bar (72-3000 PSI) M - 10-350 Bar (144-5000 PSI)
Maximum Pressure Setting	420 Bar (6000 PSI)
Maximum Tank Pressure	420 Bar (6000 PSI)
Leakage at 150 SSU (32 cSt)	10 drops/min. @ 100 Bar (1450 PSI)
Cartridge Material	All parts steel. All operating parts hardened steel.
Operating Temp. Range/Seals	-40°C to +93.3°C (Nitrile) (-40°F to +200°F) -31.7°C to +121.1°C (Fluorocarbon) (-25°F to +250°F)
Fluid Compatibility/Viscosity	Mineral-based or synthetic with lubricating properties at viscosities of 45 to 2000 SSU (6 to 420 cSt)
Filtration	ISO Code 16/13, SAE Class 4 or better
Approx. Weight	0.29 kg (0.64 lbs.)
Cavity	C10-2 (See BC Section for more details)
Form Tool	Rougher None Finisher

Application

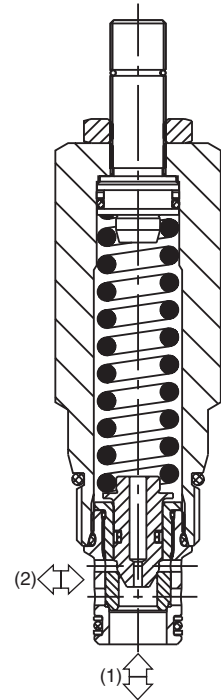
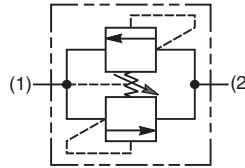
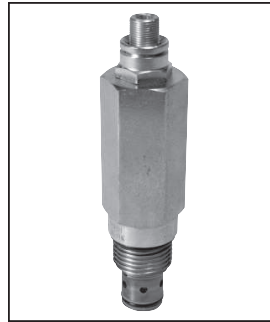
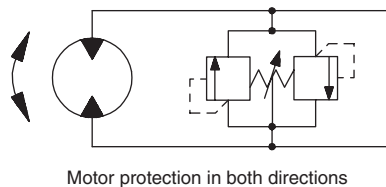

Performance Curves

(Pressure rise through cartridge only)

Flow vs. Inlet Pressure 1 to 2 and 2 to 1

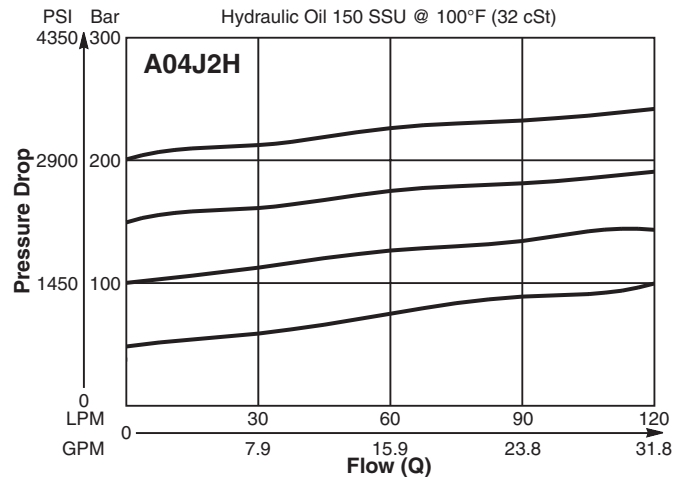

Flow vs. Inlet Pressure 1 to 2 and 2 to 1

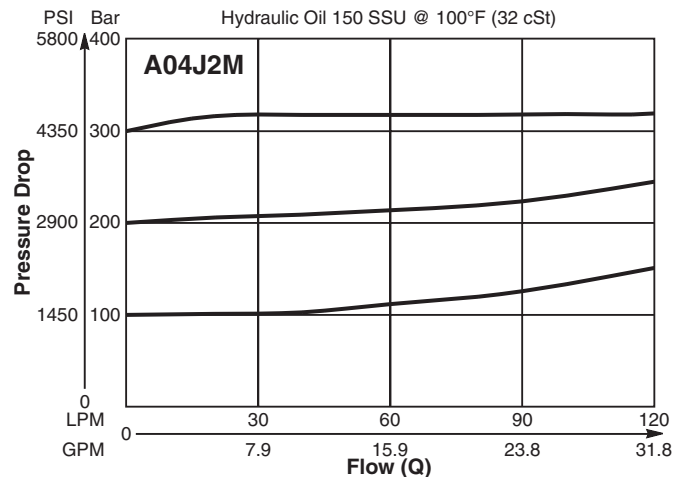

Dimensions Millimeters (Inches)

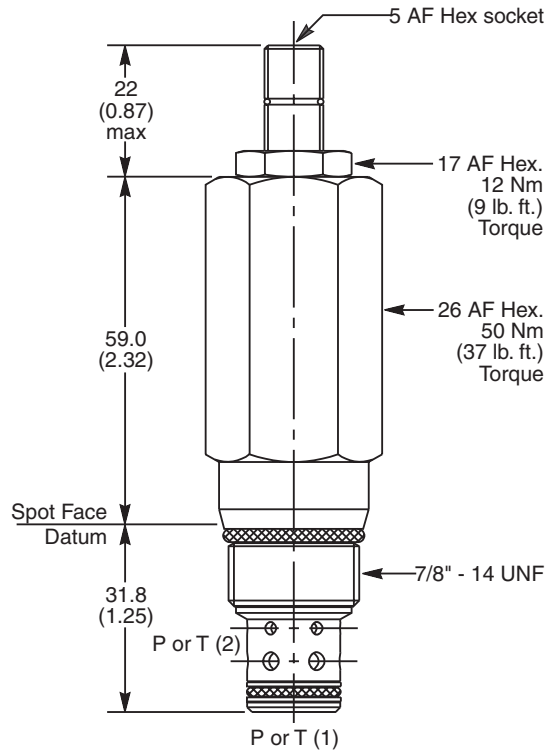

Ordering Information

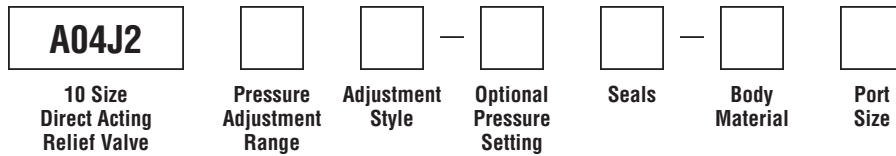

Code	Pressure Adjustment Range
H	5 - 210 Bar (72 - 3000 PSI)
M	10 - 350 Bar (144 - 5000 PSI)

Code	Seals / Kit No.
N	Nitrile, Buna-N (Std.) / (SK30529N-1)
V	Fluorocarbon / (SK30529V-1)

Code	Body Material
Omit	Steel
A	Aluminum

Code	Adjustment Style / Kit No.
Z	Screw Adjust (Std.)
W	Knob Adjust
T	Tamper Resistant Cap (TC1130)

Code	Port Size	Body Part No.
Omit	Cartridge Only	
4P	1/4" NPTF	(B10-2-*4P)
6P	3/8" NPTF	(B10-2-*6P)
8P	1/2" NPTF	(B10-2-*8P)
6T	SAE-6	(B10-2-*6T)
8T	SAE-8	(B10-2-*8T)
6B	3/8" BSPG	(B10-2-6B)†

Optional Pressure Setting	
Specify setting if required (Bar)	
A04J2H Standard Setting: 100 Bar (1450 PSI) @ 15 LPM (4.0 GPM)	
A04J2M Standard Setting: 200 Bar (2900 PSI) @ 15 LPM (4.0 GPM)	

* Add "A" for aluminum, omit for steel.
 † Steel body only.

Technical Information

- CV** Check Valves
- SH** Shuttle Valves
- LM** Load/Motor Controls
- FC** Flow Controls
- PC** Pressure Controls
- LE** Logic Elements
- DC** Directional Controls
- MV** Manual Valves
- SV** Solenoid Valves
- PV** Proportional Valves
- CE** Coils & Electronics
- BC** Bodies & Cavities
- TD** Technical Data

General Description

Direct Acting Poppet-Type Relief Valve. Pressure Equipment Directive (PED 97/23/EC) compliant to hazard category IV. For additional information see Technical Tips on pages PC1-PC6.

Features

- Bi-directional flow design for installation flexibility and security
- Compact space saving design
- Poppet type construction for lower leakage
- Full 350 Bar (5000 PSI) pressure capability
- High flow compatibility for the size of valve
- Minimal pressure variation with flow change
- Hardened working parts for maximum durability
- Tamperproof setting
- All external parts zinc plated

Specifications

Rated Flow	120 LPM (32 GPM)
Maximum Inlet Pressure	350 Bar (5000 PSI)
Maximum Pressure Setting	HY - 5-210 Bar (72-3000 PSI) MY - 10-350 Bar (145-5000 PSI)
Sensitivity: Pressure/Turn	HY - 25 Bar (362 PSI) MY - 34 Bar (493 PSI)
Leakage at 150 SSU (32 cSt)	10 drops/min. @ 100 Bar (1450 PSI)
Cartridge Material	All parts steel. All operating parts hardened steel.
Operating Temp. Range/Seals	-40°C to +93.3°C (Nitrile) (-40°F to +200°F) -31.7°C to +121.1°C (Fluorocarbon) (-25°F to +250°F)
Fluid Compatibility/Viscosity	Mineral-based or synthetic with lubricating properties at viscosities of 45 to 2000 SSU (6 to 420 cSt)
Filtration	ISO Code 16/13, SAE Class 4 or better
Approx. Weight	0.29 kg (0.64 lbs.)
Cavity	C10-2 (See BC Section for more details)
Form Tool	Rougher None Finisher NFT10-2F

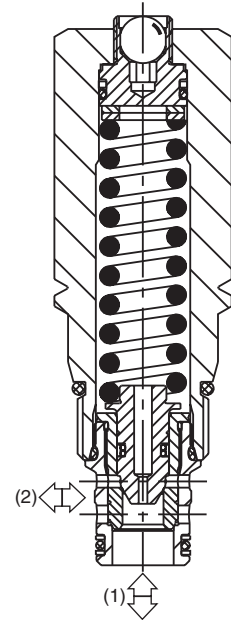
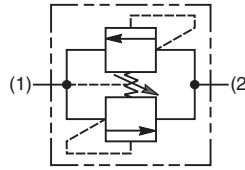

Performance Curves

(Pressure rise through cartridge only)

Flow vs. Inlet Pressure 1 to 2 and 2 to 1

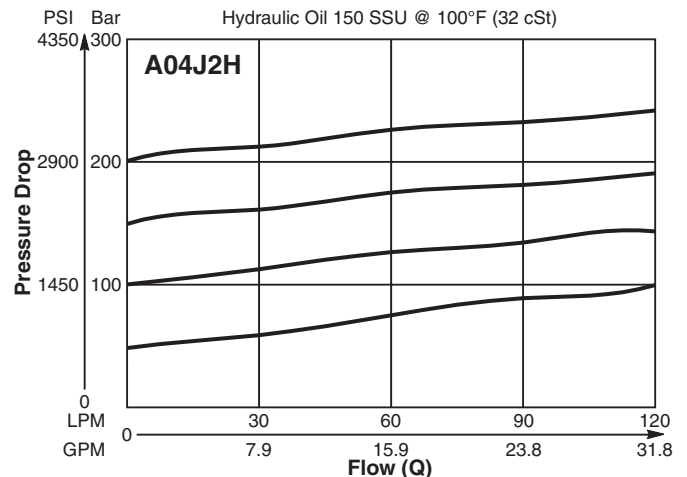

Flow vs. Inlet Pressure 1 to 2 and 2 to 1

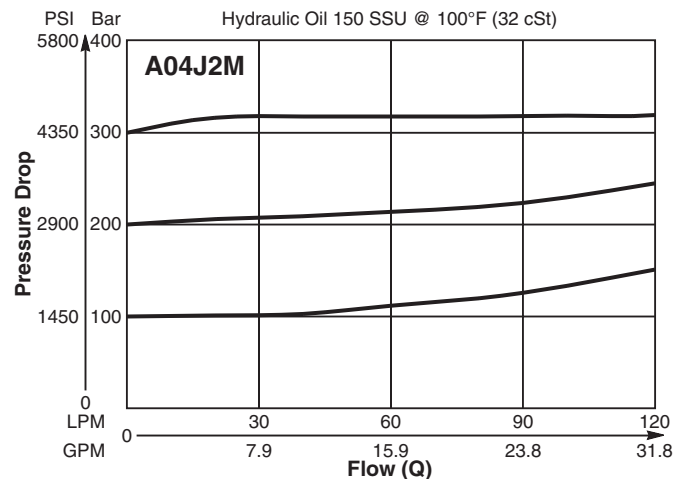

Dimensions Millimeters (Inches)

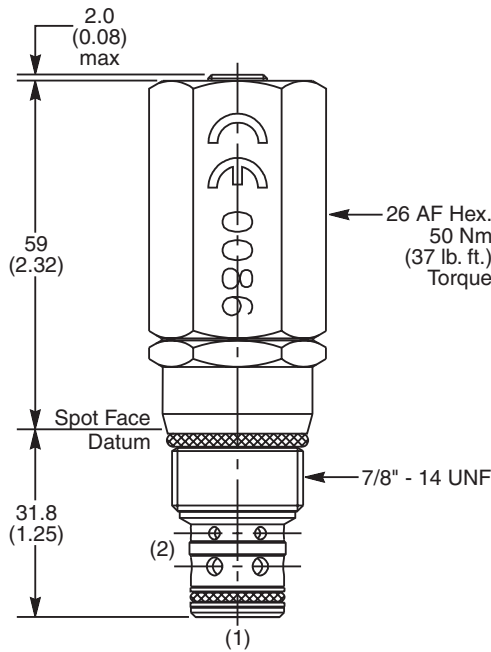

Ordering Information

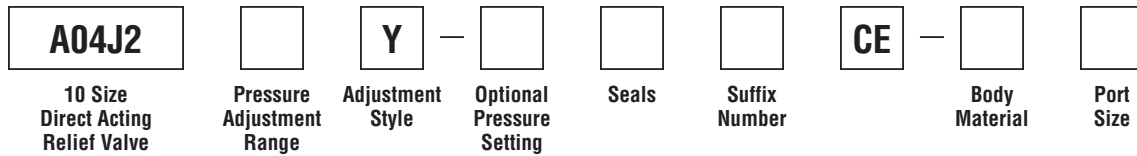

Code	Pressure Adjustment Range
H	5 - 210 Bar (72 - 3000 PSI)
M	10 - 350 Bar (145 - 5000 PSI)

Code	Seals / Kit No.
N	Nitrile, Buna-N (Std.) / (SK30529N-1)
V	Fluorocarbon / (SK30529V-1)

Code	Body Material
Omit	Steel
A	Aluminum

Code	Adjustment Style / Kit No.
Y	Non Adjustable Preset (Std.)

Code	Suffix Number
Omit	Omit for valve to be set side to nose (2 to 1)
580	For valve to be set nose to side (1 to 2)

Code	Port Size	Body Part No.
Omit	Cartridge Only	
4P	1/4" NPTF	(B10-2-*4P)
6P	3/8" NPTF	(B10-2-*6P)
8P	1/2" NPTF	(B10-2-*8P)
6T	SAE-6	(B10-2-*6T)
8T	SAE-8	(B10-2-*8T)
6B	3/8" BSPG	(B10-2-6B)†

* Add "A" for aluminum, omit for steel.
 † Steel body only.

Optional Pressure Setting
Setting must be specified (Bar)

- CV**
Check Valves
- SH**
Shuttle Valves
- LM**
Load/Motor Controls
- FC**
Flow Controls
- PC**
Pressure Controls
- LE**
Logic Elements
- DC**
Directional Controls
- MV**
Manual Valves
- SV**
Solenoid Valves
- PV**
Proportional Valves
- CE**
Coils & Electronics
- BC**
Bodies & Cavities
- TD**
Technical Data

Technical Information

- CV** Check Valves
- SH** Shuttle Valves
- LM** Load/Motor Controls
- FC** Flow Controls
- PC** Pressure Controls
- LE** Logic Elements
- DC** Directional Controls
- MV** Manual Valves
- SV** Solenoid Valves
- PV** Proportional Valves
- CE** Coils & Electronics
- BC** Bodies & Cavities
- TD** Technical Data

General Description

Dual Cross-Over Relief Valve. For additional information see Technical Tips on pages PC1-PC6.

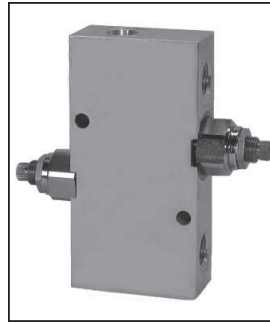

Features

- Fast acting differential area reliefs for high flow capacity
- Spherical poppets for low leakage
- Internal mechanical stop limits poppet travel eliminating spring solidification
- “D”-Ring eliminates backup rings
- All external parts have yellow zinc dichromate. This coating is ideal for salt spray applications.

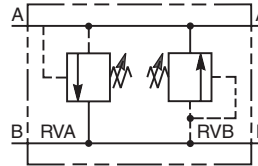

Specifications

Maximum Flow	75 LPM (20 GPM)
Maximum Inlet Pressure	350 Bar (5000 PSI)
Maximum Pressure Setting	350 Bar (5000 PSI)
Reseat Pressure	85% of crack pressure
Leakage at 150 SSU (32 cSt)	5 drops/min. (.33 cc/min.) @ 75% of crack pressure
Cartridge Material	All parts steel. All operating parts hardened steel.
Body Material	Steel
Operating Temp. Range (Ambient)	-45°C to +93.3°C (“D”-Ring) (-50°F to +200°F) -31.7°C to +121.1°C (Fluorocarbon) (-25°F to +250°F)
Filtration	ISO Code 16/13, SAE Class 4 or better
Fluids	Mineral-based or synthetic with lubricating properties at viscosities of 45 to 2000 SSU (6 to 420 cSt)
Approx. Weight	

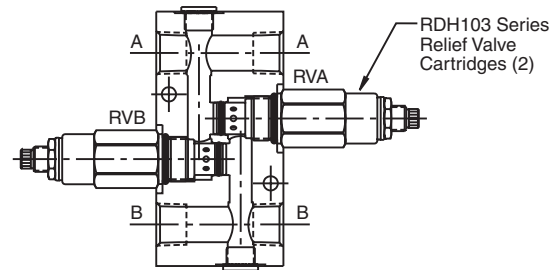

Performance Curve

Flow vs. Inlet Pressure
(Pressure rise through cartridge only)

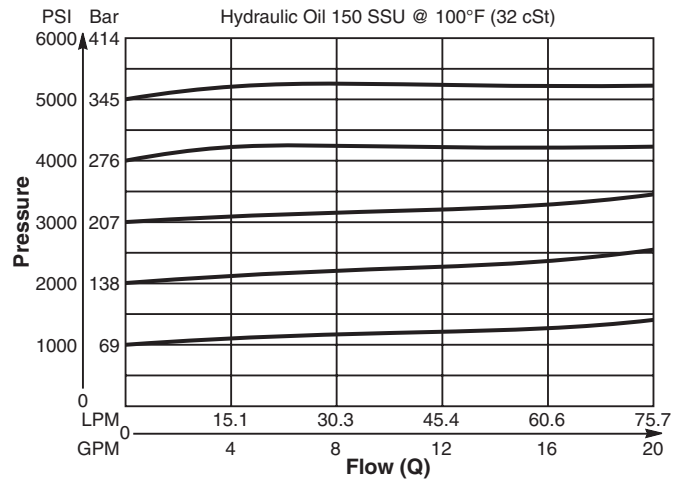

Note: A 6.9 Bar (100 PSI) pressure differential must be maintained between the two relief valve settings.

Dimensions Millimeters (Inches)

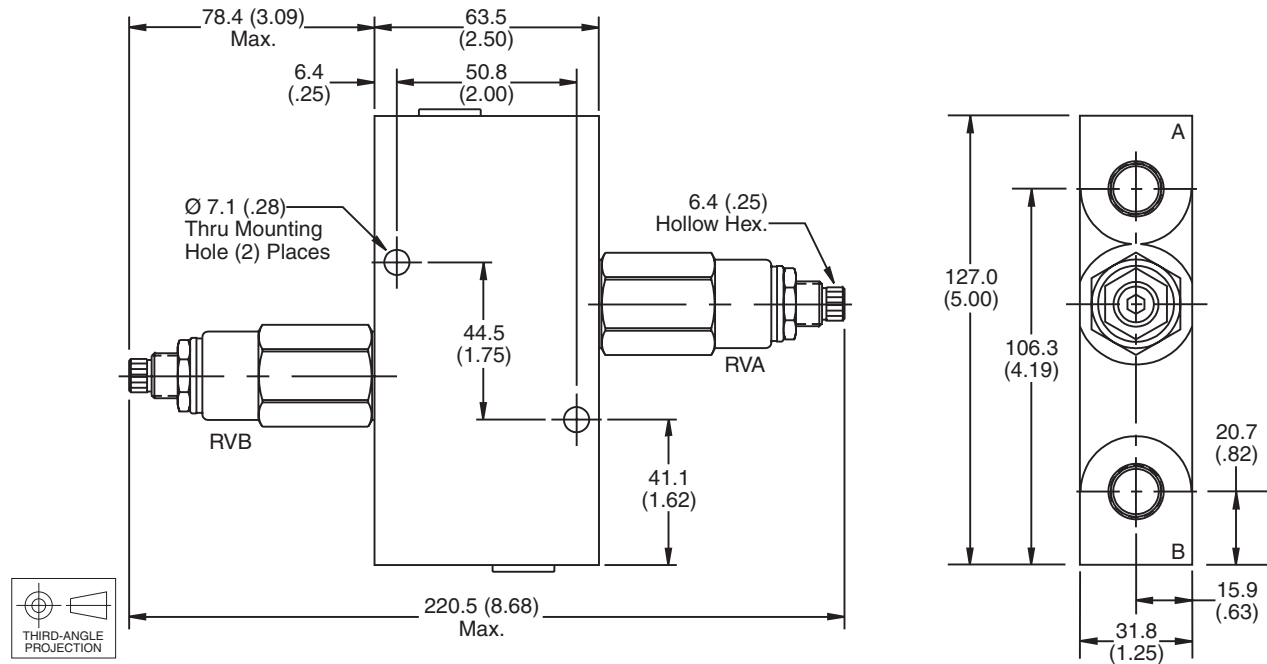

Ordering Information

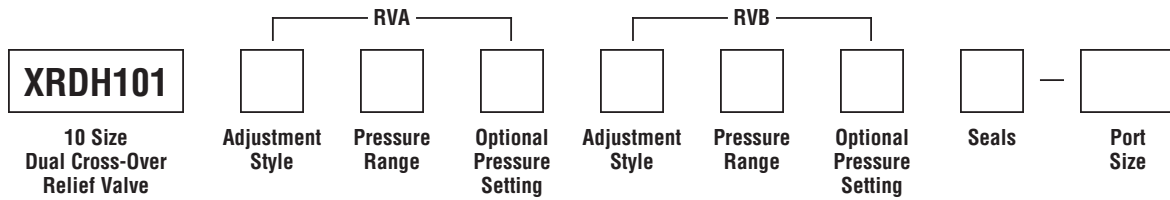

Code	Adjustment Style / Kit No.
F	Fixed style, preset at factory.
K	Knob Adjust (717784-10) (Requires 2)
S	Screw Adjust
T	Tamper Resistant Cap (717943) (Requires 2)

Optional Pressure Setting
Pressure \pm 10 i.e. 235 = 2350 PSI (Omit if standard setting is used) Setting Range: 100 to 5000 PSI All settings at 11.3 LPM (3 GPM)

Code	Port Size	Part No.
Omit	Cartridge Only	
8T	SAE-8	830318

*Steel body only.
 Individual body requires 2 SAE 6 plugs.
 Part number 6 HP50N-S.*

Code	Pressure Range
10	6.9 - 69 Bar (100 - 1000 PSI) Standard Setting: 34.5 Bar (500 PSI) @ 11.3 LPM (3 GPM)
20	34.5 - 138 Bar (500 - 2000 PSI) Standard Setting: 69 Bar (1000 PSI) @ 11.3 LPM (3 GPM)
30	69 - 207 Bar (1000 - 3000 PSI) Standard Setting: 103.5 Bar (1500 PSI) @ 11.3 LPM (3 GPM)
50	138 - 345 Bar (2000 - 5000 PSI) Standard Setting: 172.4 Bar (2500 PSI) @ 11.3 LPM (3 GPM)

Code	Seals
Omit	"D"-Ring
N	Nitrile
V	Fluorocarbon

*Note: A 6.9 Bar (100 PSI) pressure differential must be maintained between the two relief valve settings. If both reliefs are adjustable and have the same pressure range; it is not necessary to repeat the adjustment and setting.
 i.e. XRDH101S50-8T means that both A & B reliefs are screw adjustable and have a range of 138 - 345 Bar (2000 - 5000 PSI).*

Technical Information

- CV Check Valves
- SH Shuttle Valves
- LM Load/Motor Controls
- FC Flow Controls
- PC Pressure Controls
- LE Logic Elements
- DC Directional Controls
- MV Manual Valves
- SV Solenoid Valves
- PV Proportional Valves
- CE Coils & Electronics
- BC Bodies & Cavities
- TD Technical Data

General Description

Dual Cross-Over Relief Valve with anti-cavitation checks. This valve provides both overload and shock protection for double acting hydraulic actuators as well as cavitation protection. For additional information see Technical Tips on pages PC1-PC6.

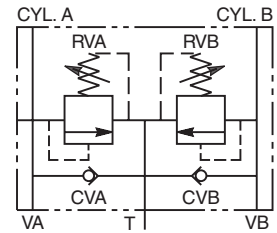
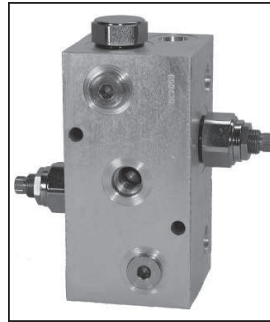

Features

- Fast acting differential area reliefs for high flow capacity
- Spherical poppets for low leakage
- Internal mechanical stop limits poppet travel eliminating spring solidification
- "D"-Ring eliminates backup rings
- All external parts have yellow zinc dichromate. This coating is ideal for salt spray applications.

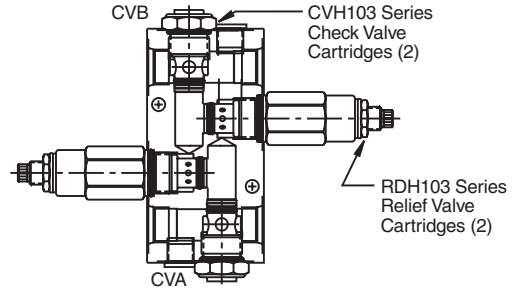

Specifications

Maximum Flow	60 LPM (16 GPM)
Maximum Inlet Pressure	380 Bar (5500 PSI)
Maximum Pressure Setting	350 Bar (5000 PSI)
Reseat Pressure	85% of crack pressure
Leakage at 150 SSU (32 cSt)	5 drops/min. (.33 cc/min.) @ 75% of crack pressure
Cartridge Material	All parts steel. All operating parts hardened steel.
Body Material	Steel
Operating Temp. Range/Seals	-45°C to +93.3°C ("D"-Ring) (-50°F to +200°F) -31.7°C to +121.1°C (Fluorocarbon) (-25°F to +250°F)
Fluid Compatibility/Viscosity	Mineral-based or synthetic with lubricating properties at viscosities of 45 to 2000 SSU (6 to 420 cSt)
Filtration	ISO Code 16/13, SAE Class 4 or better
Approx. Weight	1.8 kg (4.0 lbs.)

Note: A 6.9 Bar (100 PSI) pressure differential must be maintained between the two relief valve settings.

Performance Curve

Flow vs. Inlet Pressure
(Pressure rise through cartridge only)

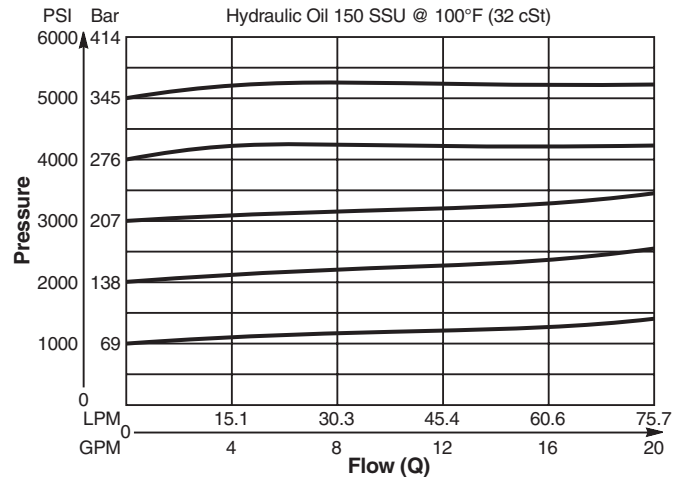

Dimensions

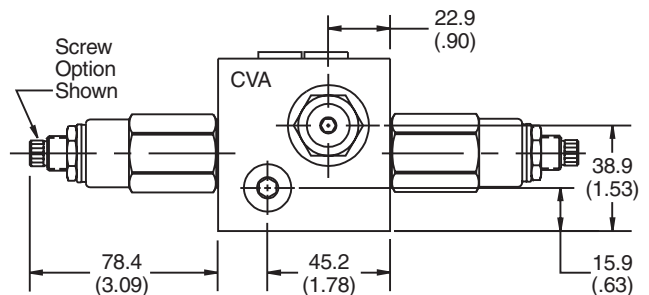

Dimensions Millimeters (Inches)

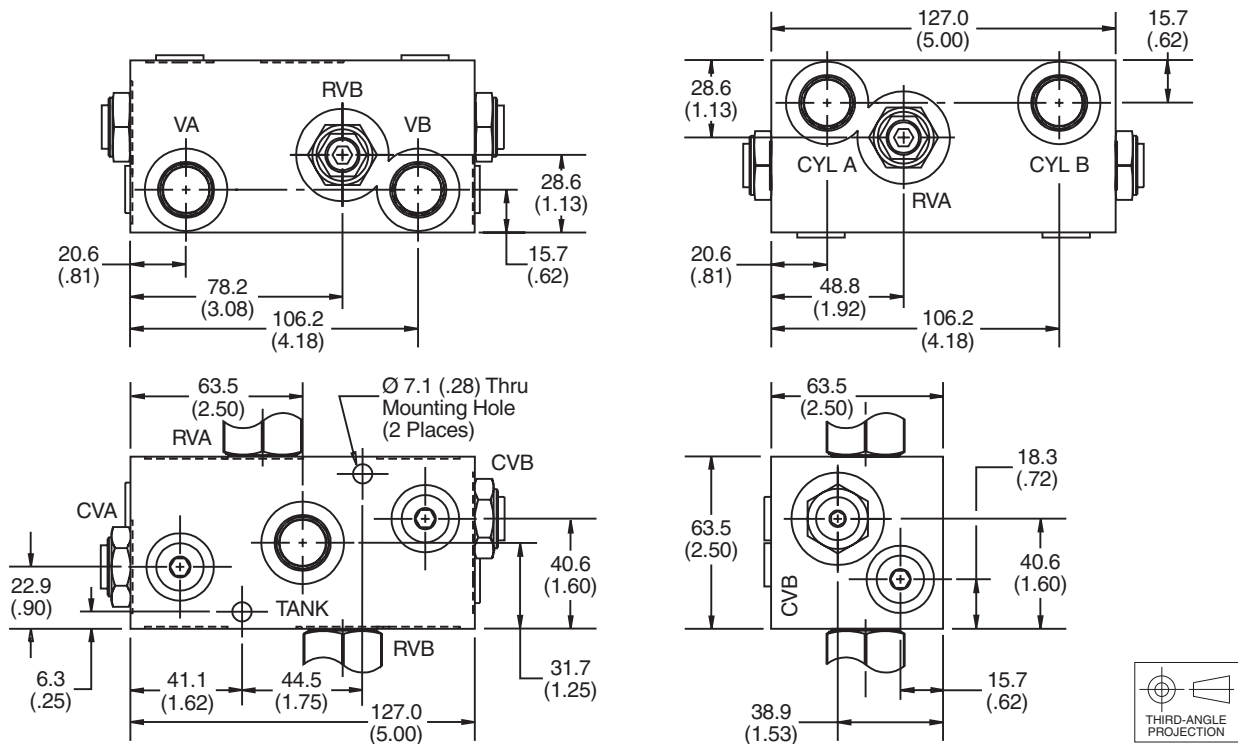

Ordering Information

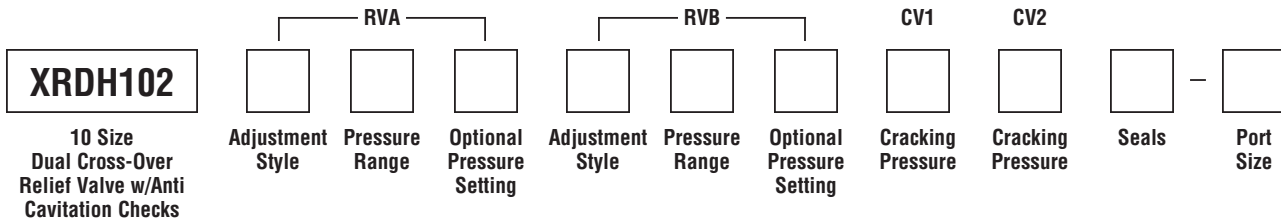

Code	Adjustment Style / Kit No.
F	Fixed style, preset at factory.
K	Knob Adjust (717784-10) (Requires 2)
S	Screw Adjust
T	Tamper Resistant Cap (717943) (Requires 2)

Optional Pressure Setting	
Pressure \pm 10 i.e. 235 = 2350 PSI (Omit if standard setting is used) Setting Range: 100 to 5000 PSI All settings at .95 LPM (.25 GPM)	

Code	Seals
Omit	"D"-Ring
N	Nitrile
V	Fluorocarbon

Code	Port Size	Part No.
8T	SAE-8	850437

Individual body requires 4 SAE 6 plugs.
 Part number 6 HP50N-S.

Code	Pressure Range
10	6.9 - 69 Bar (100 - 1000 PSI) Standard Setting: 34.5 Bar (500 PSI) @ .95 LPM (.25 GPM)
20	34.5 - 138 Bar (500 - 2000 PSI) Standard Setting: 69 Bar (1000 PSI) @ .95 LPM (.25 GPM)
30	34.5 - 207 Bar (500 - 3000 PSI) Standard Setting: 103.5 Bar (1500 PSI) @ .95 LPM (.25 GPM)
50	34.5 - 345 Bar (500 - 5000 PSI) Standard Setting: 172.4 Bar (2500 PSI) @ .95 LPM (.25 GPM)

Code	Cracking Pressure
P	0.3 Bar (5 PSI)
P20	1.4 Bar (20 PSI)
P50	3.5 Bar (50 PSI)
P65	4.5 Bar (65 PSI)
P100	6.9 Bar (100 PSI)

Note: A 6.9 Bar (100 PSI) pressure differential must be maintained between the two relief valve settings. If both reliefs are adjustable and have the same pressure range; it is not necessary to repeat the adjustment and setting.
 i.e. XRDH102S50P-T6 means that both A & B reliefs are screw adjustable and have a range of 34.5 - 345 Bar (500 - 5000 PSI).

- CV
- Check Valves
- SH
- Shuttle Valves
- LM
- Load/Motor Controls
- FC
- Flow Controls
- PC
- Pressure Controls
- LE
- Logic Elements
- DC
- Directional Controls
- MV
- Manual Valves
- SV
- Solenoid Valves
- PV
- Proportional Valves
- CE
- Coils & Electronics
- BC
- Bodies & Cavities
- TD
- Technical Data

Technical Information

- CV Check Valves
- SH Shuttle Valves
- LM Load/Motor Controls
- FC Flow Controls
- PC Pressure Controls
- LE Logic Elements
- DC Directional Controls
- MV Manual Valves
- SV Solenoid Valves
- PV Proportional Valves
- CE Coils & Electronics
- BC Bodies & Cavities
- TD Technical Data

General Description

Dual Cross-Over Relief Valve with Motor Mount. This valve provides overload and shock protection for small gerotor motors with a manifold mounting pattern, such as the Parker TB and TE series. Close coupling the valve to the motor provides ideal protection and eliminates plumbing. For additional information see Technical Tips on pages PC1-PC6.

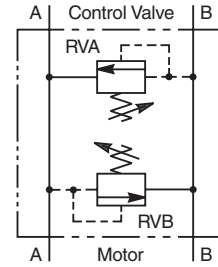
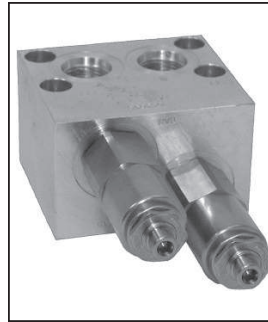

Features

- Fast acting differential area reliefs for high flow capacity
- Spherical poppets for low leakage
- Internal mechanical stop limits poppet travel eliminating spring solidification
- "D"-Ring eliminates backup rings
- All external parts have yellow zinc dichromate. This coating is ideal for salt spray applications.

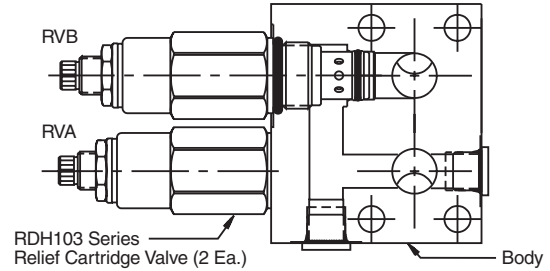

Specifications

Maximum Flow	75 LPM (20 GPM)
Maximum Inlet Pressure	380 Bar (5500 PSI)
Maximum Pressure Setting	350 Bar (5000 PSI)
Reseat Pressure	85% of crack pressure
Leakage at 150 SSU (32 cSt)	5 drops/min. (.33 cc/min.) @ 75% of crack pressure
Cartridge Material	All parts steel. All operating parts hardened steel.
Body Material	Steel
Operating Temp. Range/Seals	-45°C to +93.3°C ("D"-Ring) (-50°F to +200°F) -31.7°C to +121.1°C (Fluorocarbon) (-25°F to +250°F)
Fluid Compatibility/Viscosity	Mineral-based or synthetic with lubricating properties at viscosities of 45 to 2000 SSU (6 to 420 cSt)
Filtration	ISO Code 16/13, SAE Class 4 or better
Approx. Weight	2.0 kg (4.5 lbs.)

Note: A 6.9 Bar (100 PSI) pressure differential must be maintained between the two relief valve settings.

Performance Curve

Flow vs. Inlet Pressure

(Pressure rise through cartridge only)

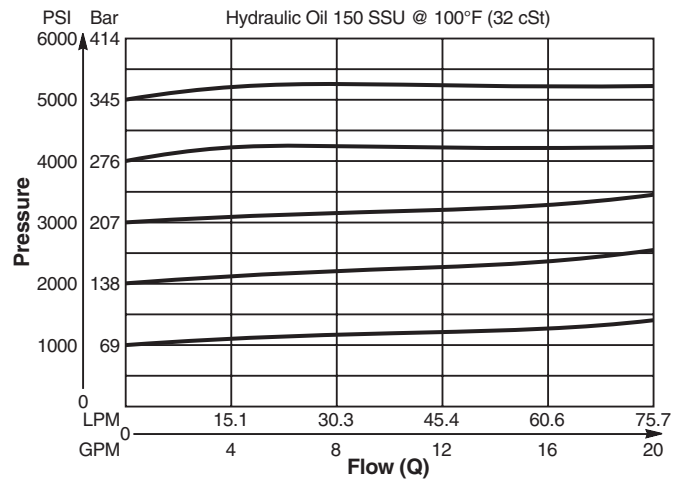

Dimensions Millimeters (Inches)

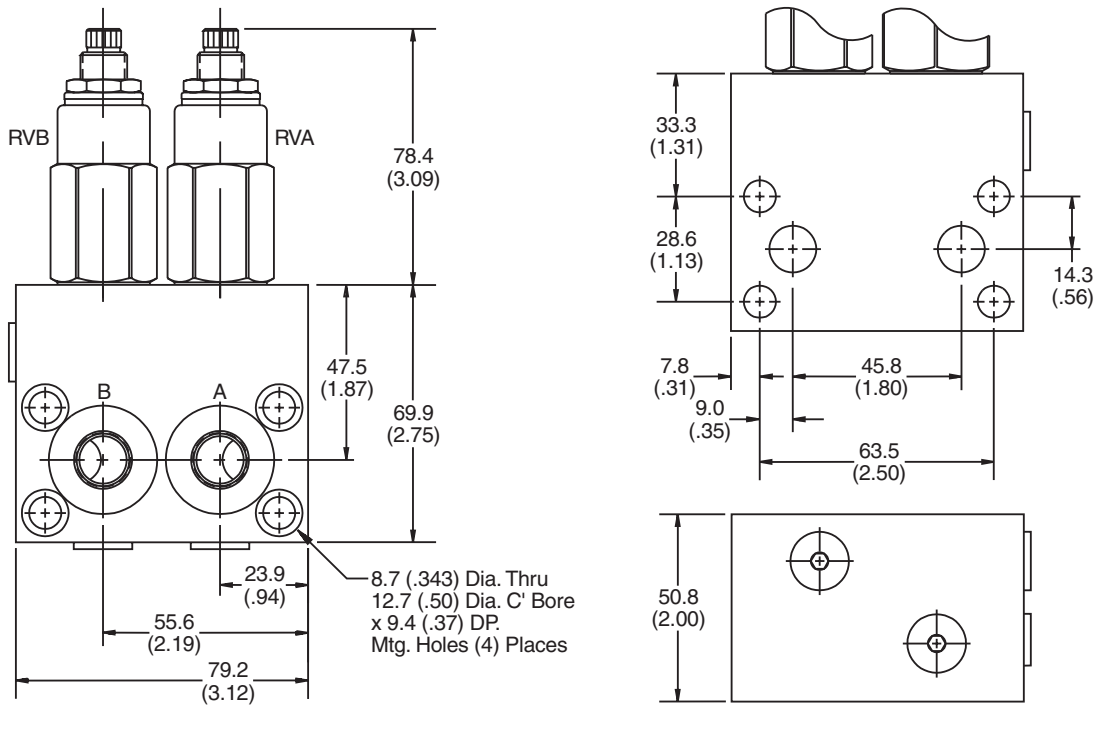

Ordering Information

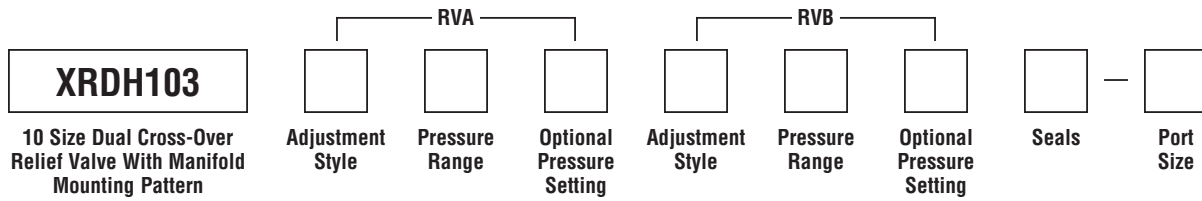

Code	Adjustment Style / Kit No.
F	Fixed style, preset at factory.
K	Knob Adjust (717784-10) (Requires 2)
S	Screw Adjust
T	Tamper Resistant Cap (717943) (Requires 2)

Optional Pressure Setting	
Pressure	± 10
	i.e. 235 = 2350 PSI
	(Omit if standard setting is used)
Setting Range:	100 to 5000 PSI
	All settings at .95 LPM (.25 GPM)

Code	Port Size	Part No.
8T	SAE-8	830338

*Individual body requires 4 SAE 5 plugs.
 Part number 5 HP50N-S.*

Code	Pressure Range
10	6.9 - 69 Bar (100 - 1000 PSI) Standard Setting: 34.5 Bar (500 PSI) @ .95 LPM (.25 GPM)
20	34.5 - 138 Bar (500 - 2000 PSI) Standard Setting: 69 Bar (1000 PSI) @ .95 LPM (.25 GPM)
30	34.5 - 207 Bar (500 - 3000 PSI) Standard Setting: 103.5 Bar (1500 PSI) @ .95 LPM (.25 GPM)
50	34.5 - 345 Bar (500 - 5000 PSI) Standard Setting: 172.4 Bar (2500 PSI) @ .95 LPM (.25 GPM)

Code	Seals
Omit	"D"-Ring
N	Nitrile
V	Fluorocarbon

*Note: A 6.9 Bar (100 PSI) pressure differential must be maintained between the two relief valve settings. If both reliefs are adjustable and have the same pressure range; it is not necessary to repeat the adjustment and setting.
 i.e. XRDH10350-6T means that both A & B reliefs are screw adjustable and have a range of 34.5 - 345 Bar (500 - 5000 PSI).*

Technical Information

- CV** Check Valves
- SH** Shuttle Valves
- LM** Load/Motor Controls
- FC** Flow Controls
- PC** Pressure Controls
- LE** Logic Elements
- DC** Directional Controls
- MV** Manual Valves
- SV** Solenoid Valves
- PV** Proportional Valves
- CE** Coils & Electronics
- BC** Bodies & Cavities
- TD** Technical Data

General Description

Differential Area Unloading Relief Valve. This valve is best suited for low flow accumulator unloading circuits or can be used as remote pilot valves. They provide a fixed percentage between load and unload pressures. For additional information see Technical Tips on pages PC1-PC6.

Features

- Low hysteresis
- Cartridge design
- All external parts zinc plated

Specifications

Rated Flow	3.75 LPM (1 GPM)
Maximum Pilot Flow	.94 LPM (.25 GPM)
Maximum Inlet Pressure	245 Bar (3500 PSI)
Maximum Pressure Setting	210 Bar (3000 PSI)
Maximum Tank Pressure	210 Bar (3000 PSI)
Leakage at 150 SSU (32 cSt)	Port 2 to 3 10 drops/min. (0.66 cc/min.) Port 1 to 2 60 drops/min. (3 cc/min.)
Cartridge Material	All parts steel. All operating parts hardened steel.
Operating Temp. Range/Seals	-40°C to +93.3°C (Nitrile) (-40°F to +200°F) -31.7°C to +121.1°C (Fluorocarbon) (-25°F to +250°F)
Fluid Compatibility/Viscosity	Mineral-based or synthetic with lubricating properties at viscosities of 45 to 2000 SSU (6 to 420 cSt)
Filtration	ISO Code 16/13, SAE Class 4 or better
Approx. Weight	.23 kg (.50 lbs.)
Cavity	C10-3 (See BC Section for more details)
Form Tool	Rougher NFT10-3R Finisher NFT10-3F

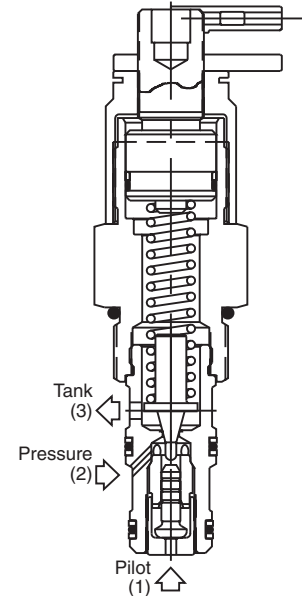
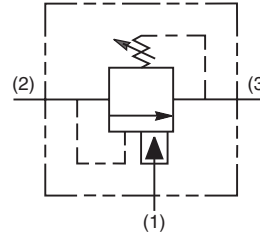
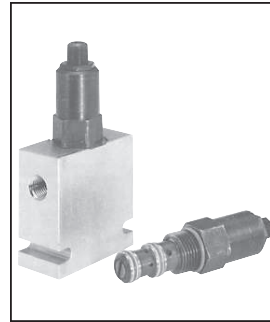

Performance Curve

Inlet Flow vs. Pressure Drop

Without pilot assist (Through cartridge only)

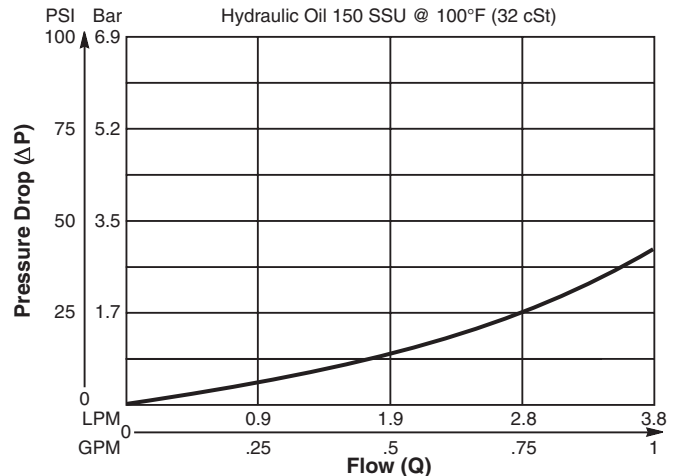

Dimensions Millimeters (Inches)

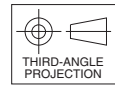
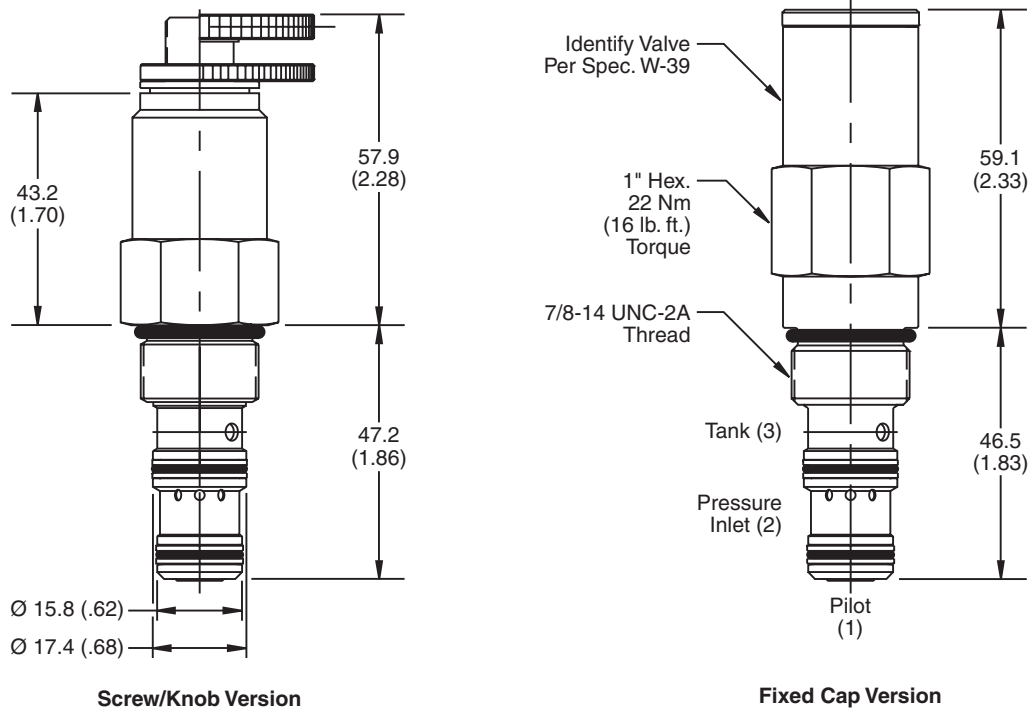

Ordering Information

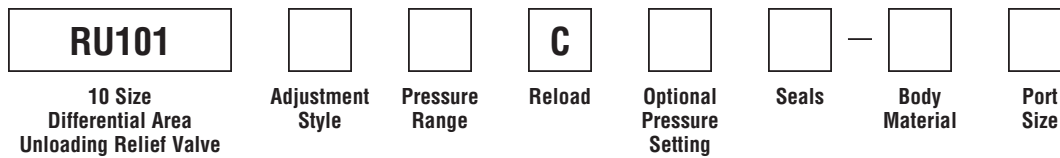

Code	Adjustment Style / Kit No.
F	Fixed style, preset at factory.
K	Knob Adjust (840208K)
S	Screw Adjust

Code	Reload
C	80% ±5% of Pressure Setting

Code	Body Material
Omit	Steel
A	Aluminum

Code	Pressure Range
10	6.9 - 69 Bar (100 - 1000 PSI) Standard Setting: 34.5 Bar (500 PSI) @ 1.1 LPM (.3 GPM)
20	10.3 - 138 Bar (150 - 2000 PSI) Standard Setting: 69 Bar (1000 PSI) @ 1.1 LPM (.3 GPM)
30	13.8 - 207 Bar (200 - 3000 PSI) Standard Setting: 103.5 Bar (1500 PSI) @ 1.1 LPM (.3 GPM)

Optional Pressure Setting
Pressure + 10 i.e. 235 = 2350 PSI (Omit if standard setting is used) Setting Range: 100 to 3000 PSI All settings at 1.1 LPM (0.3 GPM)

Code	Seals / Kit No.
Omit	Nitrile / (SK10-3N)
V	Fluorocarbon / (SK10-3V)

Code	Port Size	Body Part No.
Omit	Cartridge Only	
4P	1/4" NPTF	(B10-3-*4P)
6P	3/8" NPTF	(B10-3-*6P)
8P	1/2" NPTF	(B10-3-*8P)
6T	SAE-6	(B10-3-*6T)
8T	SAE-8	(B10-3-*8T)
6B	3/8" BSPG	(B10-3-6B)†
8B	1/2" BSPG	(B10-3-*8B)

* Add "A" for aluminum, omit for steel.
 † Steel body only.

- CV** Check Valves
- SH** Shuttle Valves
- LM** Load/Motor Controls
- FC** Flow Controls
- PC** Pressure Controls
- LE** Logic Elements
- DC** Directional Controls
- MV** Manual Valves
- SV** Solenoid Valves
- PV** Proportional Valves
- CE** Coils & Electronics
- BC** Bodies & Cavities
- TD** Technical Data

Technical Information

- CV** Check Valves
- SH** Shuttle Valves
- LM** Load/Motor Controls
- FC** Flow Controls
- PC** Pressure Controls
- LE** Logic Elements
- DC** Directional Controls
- MV** Manual Valves
- SV** Solenoid Valves
- PV** Proportional Valves
- CE** Coils & Electronics
- BC** Bodies & Cavities
- TD** Technical Data

General Description

Direct Acting, Spool-Type, Unloading Relief Valve with Internal Pilot. For additional information see Technical Tips on pages PC1-PC6.

Features

- Use to unload a load sense pump in an accumulator circuit
- One size unloading valve for all flow size applications
- Hardened working parts for maximum durability
- Adjustable and tamperproof versions available
- All external parts zinc plated

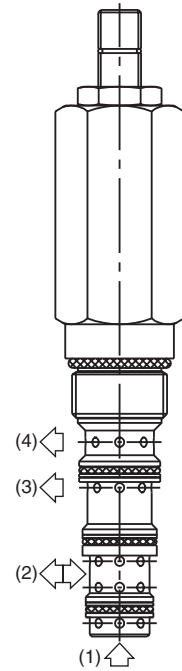
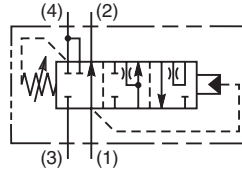
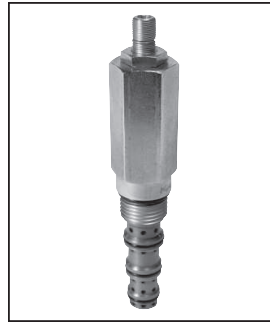

Specifications

Rated Flow	2 LPM (0.53 GPM)
Maximum Inlet Pressure	420 Bar (6000 PSI)
Maximum Pressure Setting	200 Bar (2900 PSI)
Maximum Tank Pressure	420 Bar (6000 PSI)
Leakage at 150 SSU (32 cSt)	25 ml/min. @ 100 Bar (1450 PSI)
Cartridge Material	All parts steel. All operating parts hardened steel.
Operating Temp. Range/Seals	-40°C to +93.3°C (Nitrile) (-40°F to +200°F) -31.7°C to +121.1°C (Fluorocarbon) (-25°F to +250°F)
Fluid Compatibility/Viscosity	Mineral-based or synthetic with lubricating properties at viscosities of 45 to 2000 SSU (6 to 420 cSt)
Filtration	ISO Code 16/13, SAE Class 4 or better
Approx. Weight	0.33 kg (0.73 lbs.)
Cavity	C10-4 (See BC Section for more details)
Form Tool	Rougher None Finisher

**Performance Curve
Accumulator Circuit**

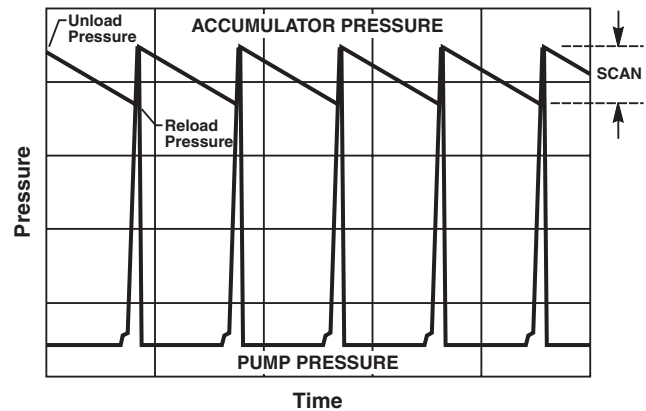

Application

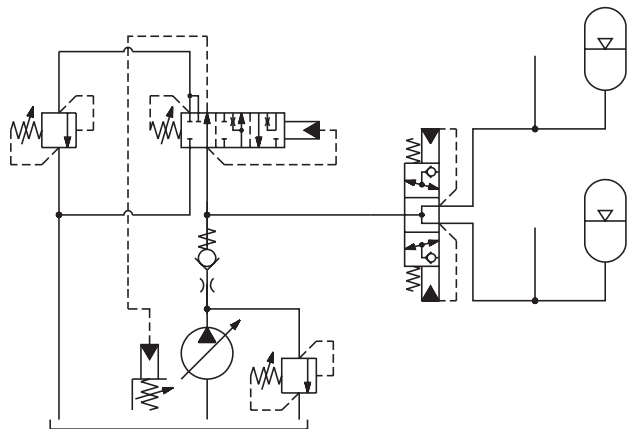

Dimensions Millimeters (Inches)

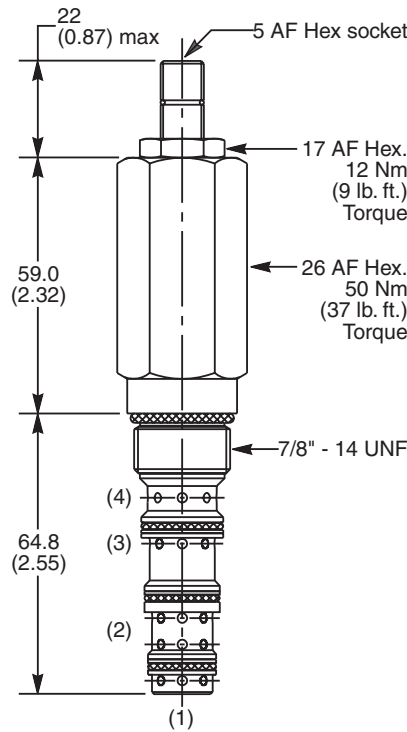

Ordering Information

M04A4	J					
10 Size Direct Acting Unloading Relief Valve	Reload Pressure Adjustment Range	Adjustment Style	Reload Pressure Setting	Seals	Body Material	Port Size

Code	Reload Pressure Adjustment Range
J	50 - 200 Bar (725 - 2900 PSI)

Code	Seals / Kit No.
N	Nitrile, Buna-N (Std.) / (SK30530N-1)
V	Fluorocarbon / (SK30530V-1)

Code	Port Size	Body Part No.
Omit	Cartridge Only	
4P	1/4" NPTF	(B10-4-*4P)
6P	3/8" NPTF	(B10-4-*6P)
8P	1/2" NPTF	(B10-4-*8P)
6T	SAE-6	(B10-4-*6T)
8T	SAE-8	(B10-4-*8T)
T8T	SAE-8	(B10-4-T8T)†
6B	3/8" BSPG	(B10-4-6B)†

Code	Adjustment Style / Kit No.
Z	Screw Adjust (Std.)
T	Tamper Resistant Cap (TC1130)

Code	Body Material
Omit	Steel
A	Aluminum

Code	Reload Pressure Setting
Omit	Omit for standard setting Specify setting if required M04A4J Standard Setting: 125 Bar (1850 PSI)

* Add "A" for aluminum. omit for steel.
 † Steel body only.

- CV**
Check Valves
- SH**
Shuttle Valves
- LM**
Load/Motor Controls
- FC**
Flow Controls
- PC**
Pressure Controls
- LE**
Logic Elements
- DC**
Directional Controls
- MV**
Manual Valves
- SV**
Solenoid Valves
- PV**
Proportional Valves
- CE**
Coils & Electronics
- BC**
Bodies & Cavities
- TD**
Technical Data

Technical Information

- CV** Check Valves
- SH** Shuttle Valves
- LM** Load/Motor Controls
- FC** Flow Controls
- PC** Pressure Controls
- LE** Logic Elements
- DC** Directional Controls
- MV** Manual Valves
- SV** Solenoid Valves
- PV** Proportional Valves
- CE** Coils & Electronics
- BC** Bodies & Cavities
- TD** Technical Data

General Description

Pilot Operated, Poppet-Type Relief Valve with Free Reverse Check. For additional information see Technical Tips on pages PC1-PC6.

Features

- High flow capacity
- Virtually leak free, can be used for load holding applications
- Compact space saving design
- Hardened working parts for maximum durability
- Adjustable and tamperproof versions available
- All external parts zinc plated

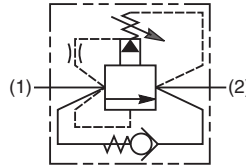
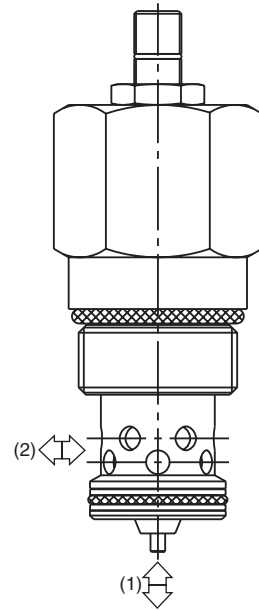
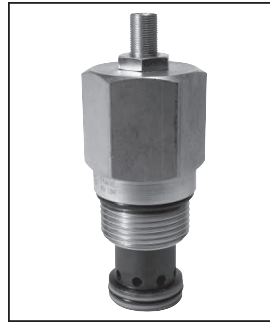

Specifications

Rated Flow	350 LPM (92 GPM)
Maximum Inlet Pressure	420 Bar (6000 PSI)
Maximum Pressure Setting	H - 10-210 Bar (145-3000 PSI) P - 10-420 Bar (145-6000 PSI)
Maximum Tank Pressure	420 Bar (6000 PSI)
Leakage at 150 SSU (32 cSt)	5 drops/min. @ 100 Bar (1450 PSI)
Cartridge Material	All parts steel. All operating parts hardened steel.
Operating Temp. Range/Seals	-40°C to +93.3°C (Nitrile) (-40°F to +200°F) -31.7°C to +121.1°C (Fluorocarbon) (-25°F to +250°F)
Fluid Compatibility/Viscosity	Mineral-based or synthetic with lubricating properties at viscosities of 45 to 2000 SSU (6 to 420 cSt)
Filtration	ISO Code 16/13, SAE Class 4 or better
Approx. Weight	0.57 kg (1.26 lbs.)
Cavity	C16-2 (See BC Section for more details)
Form Tool	Rougher None Finisher NFT16-2F

Performance Curves

(Pressure rise through cartridge only)

Relief Performance 1 to 2

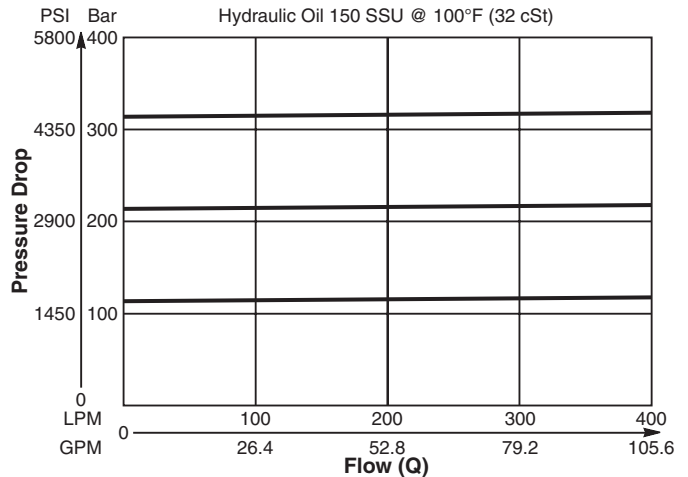

Pressure Drop vs. Flow 2 to 1

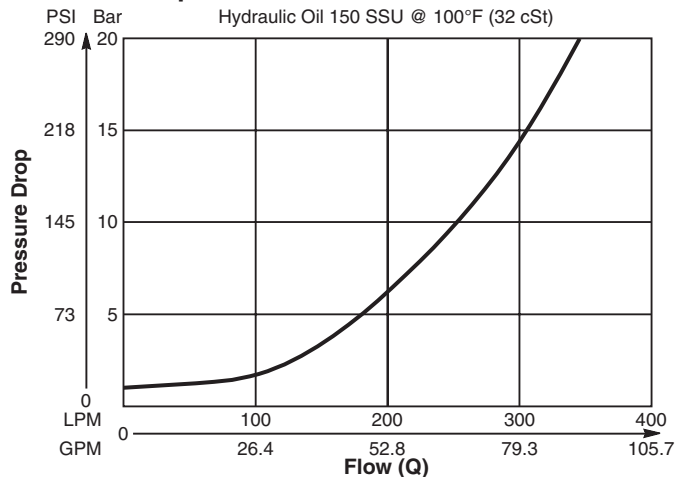

Dimensions Millimeters (Inches)

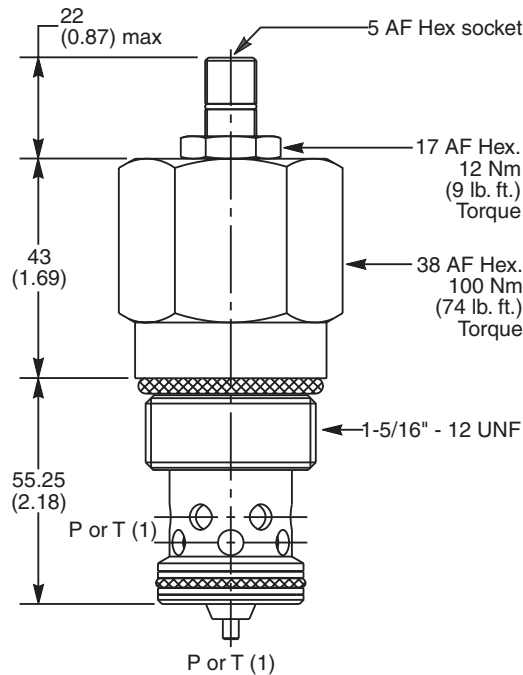

Ordering Information

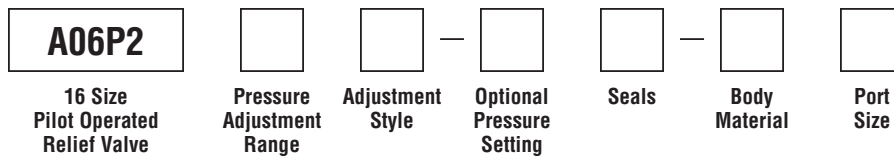

Code	Pressure Adjustment Range
H	10 - 210 Bar (145 - 3000 PSI)
P	10 - 420 Bar (145 - 6000 PSI)

Code	Seals / Kit No.
N	Nitrile, Buna-N (Std.) / (SK30507N-1)
V	Fluorocarbon / (SK30507V-1)

Code	Body Material
Omit	Steel
A	Aluminum

Code	Adjustment Style / Kit No.
Z	Screw Adjust (Std.)
W	Knob Adjust
T	Tamper Resistant Cap (TC1130)

Code	Port Size	Body Part No.
Omit	Cartridge Only	
12P	3/4" NPTF	(B16-2-*12P)
16P	1" NPTF	(B16-2-*16P)
8T	SAE-8	(B16-2-*8T)
12T	SAE-12	(B16-2-*12T)
16T	SAE-16	(B16-2-*16T)
12B	3/4" BSPG	(B16-2-12B)†
16B	1" BSPG	(B16-2-*16B)

Optional Pressure Setting	
Specify setting if required (Bar)	
A06P2H Standard Setting: 100 Bar (1450 PSI) @ 20 LPM (5.3 GPM)	
A06P2P Standard Setting: 200 Bar (2900 PSI) @ 20 LPM (5.3 GPM)	

* Add "A" for aluminum, omit for steel.
 † Steel body only.

Technical Information

- CV** Check Valves
- SH** Shuttle Valves
- LM** Load/Motor Controls
- FC** Flow Controls
- PC** Pressure Controls
- LE** Logic Elements
- DC** Directional Controls
- MV** Manual Valves
- SV** Solenoid Valves
- PV** Proportional Valves
- CE** Coils & Electronics
- BC** Bodies & Cavities
- TD** Technical Data

General Description

Pilot Operated Sequence Valve (Internally Piloted, Externally Vented). For additional information see Technical Tips on pages PC1-PC6.



Features

- Hardened, precision ground parts for durability
- Low profile adapter for minimal space requirements
- Fully guided pilot for more consistent reseal
- Steel adapters are coated with yellow zinc dichromate for protection from salt spray
- Polyurethane "D"-Ring eliminates backup rings and prevents hydrolysis
- Internal screening protects pilot spring from debris

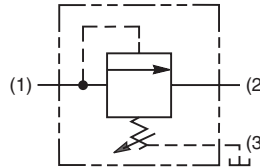
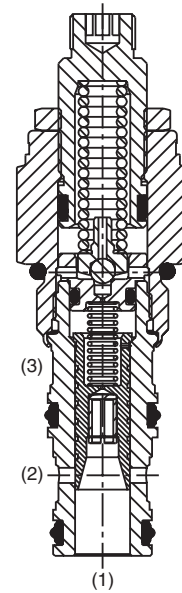
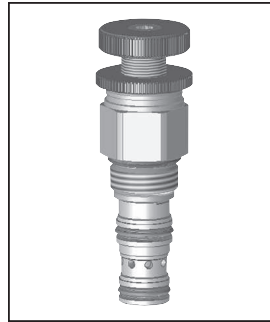

Specifications

Rated Flow	45 LPM (12 GPM)
Maximum Inlet Pressure	380 Bar (5500 PSI)
Maximum Pressure Setting	350 Bar (5000 PSI)
Maximum Tank Pressure	350 Bar (5000 PSI)
Maximum Drain Flow	0.56 LPM (0.15 GPM)
Reseat Pressure	90% of crack pressure
Leakage at 150 SSU (32 cSt)	82 cc/min. (5 cu. in./min.) @ 210 Bar (3000 PSI)
Cartridge Material	All parts steel. All operating parts hardened steel.
Operating Temp. Range/Seals	-45°C to +93.3°C ("D"-Ring) (-50°F to +200°F) -31.7°C to +121.1°C (Fluorocarbon) (-25°F to +250°F)
Fluid Compatibility/Viscosity	Mineral-based or synthetic with lubricating properties at viscosities of 45 to 2000 SSU (6 to 420 cSt)
Filtration	ISO Code 16/13, SAE Class 4 or better
Approx. Weight	.11 kg (.25 lbs.)
Cavity	C08-3 (See BC Section for more details)
Form Tool	Rougher NTF08-3R Finisher NFT08-3F

Performance Curves

Flow vs. Inlet Pressure

(Pressure rise through cartridge only)

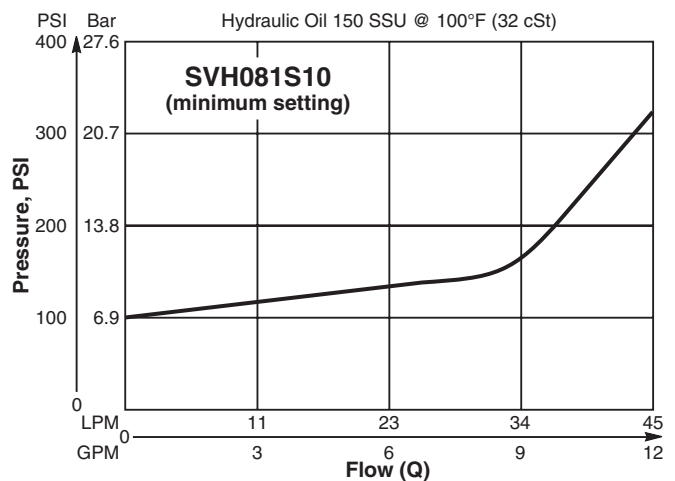
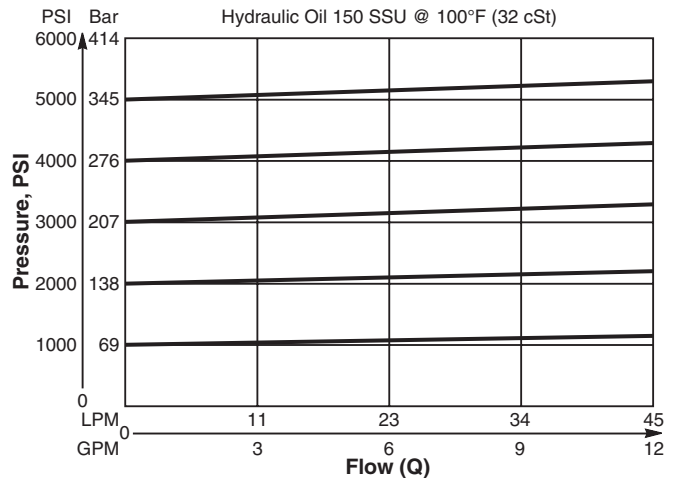

Dimensions Millimeters (Inches)

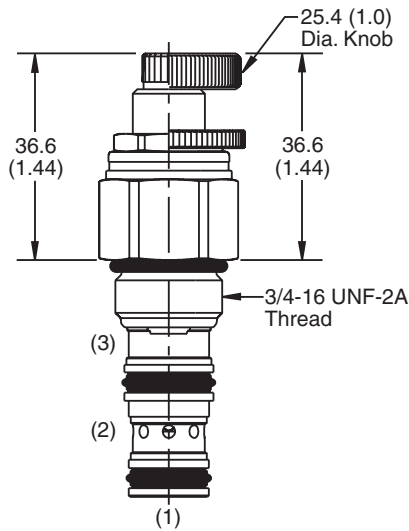

Screw/Knob Version

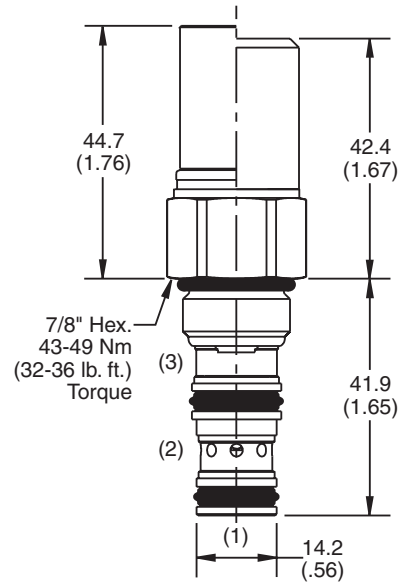

Fixed Cap/Tamper Resistant Version

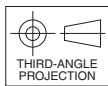

Ordering Information

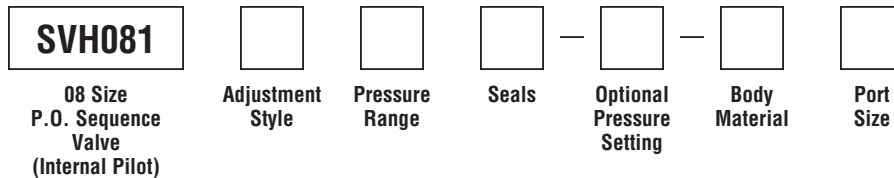

Code	Adjustment Style / Kit No.
F	Fixed style, preset at factory.
K	Knob Adjust (717784-10)
S	Screw Adjust
T	Tamper Resistant Cap (717943)

Code	Seals / Kit No.
Omit	"D"-Ring / (SK08-3)
N	Nitrile / (SK08-3N)
V	Fluorocarbon / (SK08-3V)

Code	Body Material
Omit	Steel
A	Aluminum

Code	Pressure Range
10	6.9 - 69 Bar (100 - 1000 PSI) Standard Setting: 34.5 Bar (500 PSI) @ crack pressure, approximately .95 LPM (.25 GPM)
20	6.9 - 138 Bar (100 - 2000 PSI) Standard Setting: 69 Bar (1000 PSI) @ crack pressure, approximately .95 LPM (.25 GPM)
30	13.8 - 207 Bar (200 - 3000 PSI) Standard Setting: 103.5 Bar (1500 PSI) @ crack pressure, approximately .95 LPM (.25 GPM)
50	13.8 - 345 Bar (200 - 5000 PSI) Standard Setting: 172.4 Bar (2500 PSI) @ crack pressure, approximately .95 LPM (.25 GPM)

Optional Pressure Setting	
Pressure	± 10 i.e. 235 = 2350 PSI (Omit if standard setting is used)
Setting Range:	100 to 5000 PSI
All settings at crack pressure,	approximately .95 LPM (.25 GPM)

Code	Port Size	Body Part No.
Omit	Cartridge Only	
4P	1/4" NPTF	(B08-3-*4P)
4T	SAE-4	(B08-3-*4T)
6T	SAE-6	(B08-3-*6T)
6B	3/8" BSPG	(B08-3-*6B)

* Add "A" for aluminum, omit for steel.

Technical Information

- CV** Check Valves
- SH** Shuttle Valves
- LM** Load/Motor Controls
- FC** Flow Controls
- PC** Pressure Controls
- LE** Logic Elements
- DC** Directional Controls
- MV** Manual Valves
- SV** Solenoid Valves
- PV** Proportional Valves
- CE** Coils & Electronics
- BC** Bodies & Cavities
- TD** Technical Data

General Description

Pilot Operated Sequence Valve (Internally Piloted, Externally Drained). For additional information see Technical Tips on pages PC1-PC6.



Features

- Hardened, precision ground parts for durability
- Low profile adapter for minimal space requirements
- Fully guided poppet for more consistent reseal
- Steel adapters are coated with yellow zinc dichromate for protection from salt spray
- Polyurethane "D"-Ring eliminates backup rings and prevents hydrolysis
- Internal screening protects pilot spring from debris

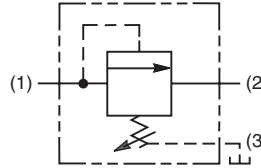
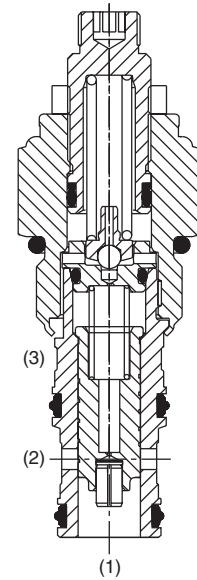

Specifications

Rated Flow	56.3 LPM (15 GPM)
Maximum Inlet Pressure	380 Bar (5500 PSI)
Maximum Pressure Setting	350 Bar (5000 PSI)
Maximum Tank Pressure	350 Bar (5000 PSI)
Maximum Drain Flow (Port 3)	0.94 LPM (0.25 GPM)
Reseat Pressure	90% of crack pressure
Leakage at 150 SSU (32 cSt)	82 cc/min. (5 cu. in./min.) @ 210 Bar (3000 PSI)
Cartridge Material	All parts steel. All operating parts hardened steel.
Operating Temp. Range/Seals	-45°C to +93.3°C ("D"-Ring) (-50°F to +200°F) -31.7°C to +121.1°C (Fluorocarbon) (-25°F to +250°F)
Fluid Compatibility/Viscosity	Mineral-based or synthetic with lubricating properties at viscosities of 45 to 2000 SSU (6 to 420 cSt)
Filtration	ISO Code 16/13, SAE Class 4 or better
Approx. Weight	.45 kg (1.0 lbs.)
Cavity	C10-3 (See BC Section for more details)
Form Tool	Rougher NTF10-3R Finisher NFT10-3F

Performance Curves

Flow vs. Inlet Pressure

(Pressure rise through cartridge only)

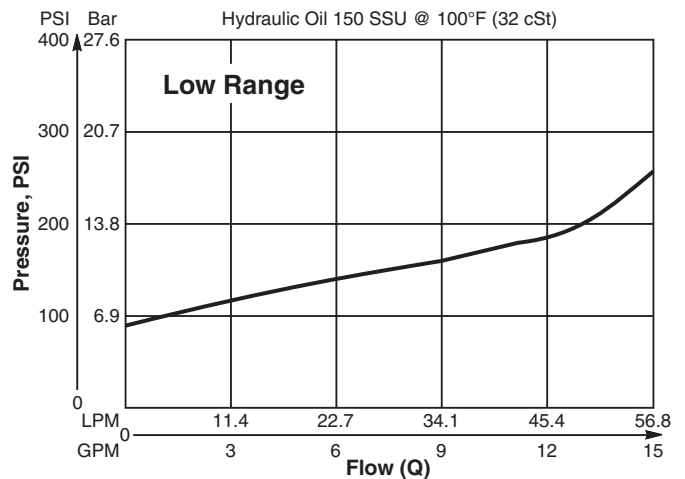
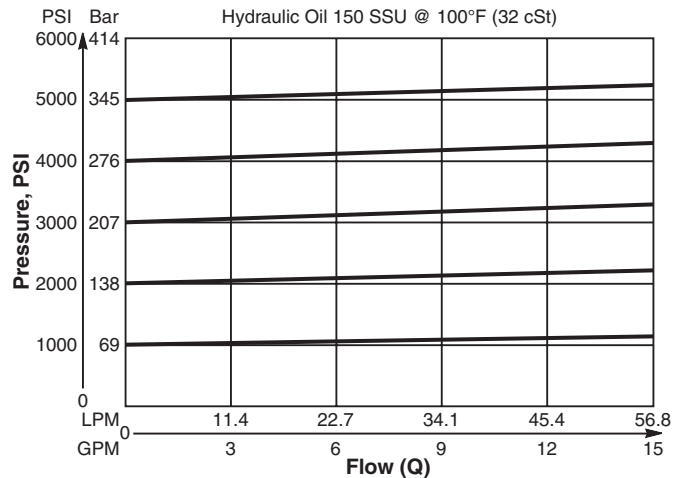

Dimensions Millimeters (Inches)

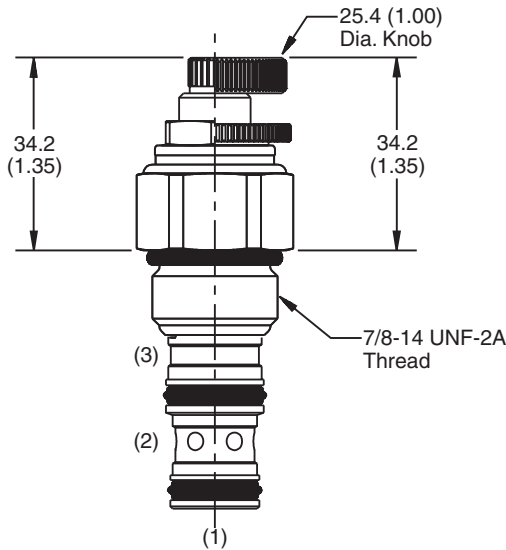

Screw/Knob Version

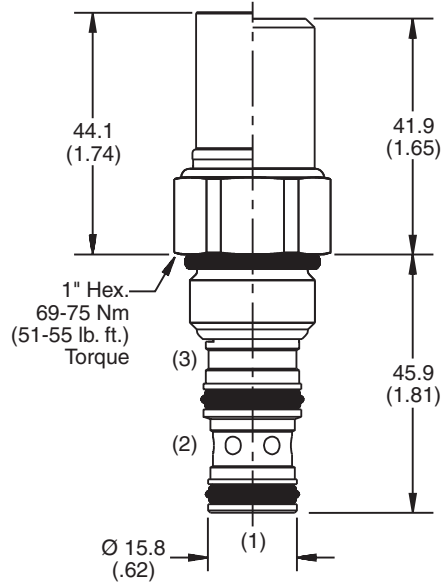

Fixed Cap/Tamper Resistant Version

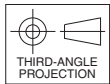

Ordering Information

SVH101	<input type="checkbox"/>	<input type="checkbox"/>	<input type="checkbox"/>	<input type="checkbox"/>	<input type="checkbox"/>	<input type="checkbox"/>
10 Size P.O. Sequence Valve (Internal Pilot)	Adjustment Style	Pressure Range	Seals	Optional Pressure Setting	Body Material	Port Size

Code	Adjustment Style / Kit No.
F	Fixed style, preset at factory.
K	Knob Adjust (717784-10)
S	Screw Adjust
T	Tamper Resistant Cap (718083)

Code	Seals / Kit No.
Omit	"D"-Ring / (SK10-3)
N	Nitrile / (SK10-3N)
V	Fluorocarbon / (SK10-3V)

Code	Body Material
Omit	Steel
A	Aluminum

Code	Pressure Range
10	6.9 - 69 Bar (100 - 1000 PSI) Standard Setting: 34.5 Bar (500 PSI) @ crack pressure, approximately .95 LPM (.25 GPM)
20	6.9 - 138 Bar (100 - 2000 PSI) Standard Setting: 69 Bar (1000 PSI) @ crack pressure, approximately .95 LPM (.25 GPM)
30	13.8 - 207 Bar (200 - 3000 PSI) Standard Setting: 103.5 Bar (1500 PSI) @ crack pressure, approximately .95 LPM (.25 GPM)
50	13.8 - 345 Bar (200 - 5000 PSI) Standard Setting: 172.4 Bar (2500 PSI) @ crack pressure, approximately .95 LPM (.25 GPM)

Optional Pressure Setting
Pressure \pm 10 i.e. 235 = 2350 PSI (Omit if standard setting is used) Setting Range: 100 to 5000 PSI All settings at crack pressure, approximately .95 LPM (.25 GPM)

Code	Port Size	Body Part No.
Omit	Cartridge Only	
4P	1/4" NPTF	(B10-3-*4P)
6P	3/8" NPTF	(B10-3-*6P)
8P	1/2" NPTF	(B10-3-*8P)
6T	SAE-6	(B10-3-*6T)
8T	SAE-8	(B10-3-*8T)
6B	3/8" BSPG	(B10-3-6B)†
8B	1/2" BSPG	(B10-3-*8B)

* Add "A" for aluminum, omit for steel.
 † Steel body only.

- CV**
Check Valves
- SH**
Shuttle Valves
- LM**
Load/Motor Controls
- FC**
Flow Controls
- PC**
Pressure Controls
- LE**
Logic Elements
- DC**
Directional Controls
- MV**
Manual Valves
- SV**
Solenoid Valves
- PV**
Proportional Valves
- CE**
Coils & Electronics
- BC**
Bodies & Cavities
- TD**
Technical Data

Technical Information

- CV** Check Valves
- SH** Shuttle Valves
- LM** Load/Motor Controls
- FC** Flow Controls
- PC** Pressure Controls
- LE** Logic Elements
- DC** Directional Controls
- MV** Manual Valves
- SV** Solenoid Valves
- PV** Proportional Valves
- CE** Coils & Electronics
- BC** Bodies & Cavities
- TD** Technical Data

General Description

Pilot Operated Sequence Valve (Internally Piloted, Externally Drained). For additional information see Technical Tips on pages PC1-PC6.

Features

- Hardened, precision ground parts for durability
- High accuracy, pilot operation design
- Ball-type pilot for added stability
- All external parts have yellow zinc dichromate. This coating is ideal for salt spray applications.

Specifications

Rated Flow	151.6 LPM (40 GPM)
Maximum Inlet Pressure	380 Bar (5500 PSI)
Maximum Pressure Setting	350 Bar (5000 PSI)
Maximum Tank Pressure	350 Bar (5000 PSI)
Maximum Drain Flow	1.9 LPM (0.5 GPM)
Reseat Pressure	80% of crack pressure
Leakage at 150 SSU (32 cSt)	5 cc per 100 PSI (6.8 Bar) setting
Cartridge Material	All parts steel. All operating parts hardened steel.
Operating Temp. Range/Seals	-40°C to +93.3°C (Nitrile) (-40°F to +200°F) -31.7°C to +121.1°C (Fluorocarbon) (-25°F to +250°F)
Fluid Compatibility/ Viscosity	Mineral-based or synthetic with lubricating properties at viscosities of 45 to 2000 SSU (6 to 420 cSt)
Filtration	ISO Code 16/13, SAE Class 4 or better
Approx. Weight	.45 kg (1.0 lbs.)
Cavity	C16-3 (See BC Section for more details)
Form Tool	Rougher NTF16-3R Finisher NFT16-3F

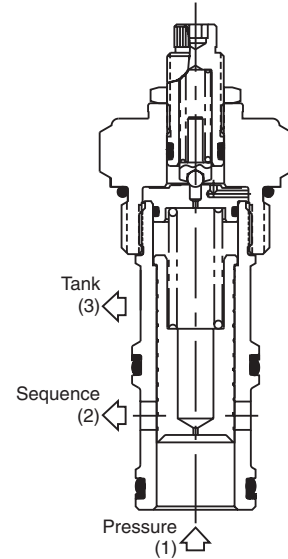
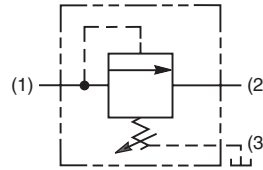

Performance Curve
Flow vs. Inlet Pressure

(Pressure rise through cartridge only)

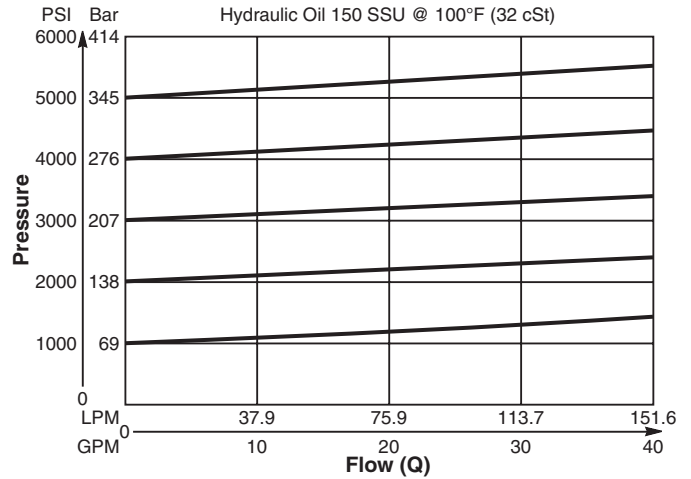

Dimensions Millimeters (Inches)

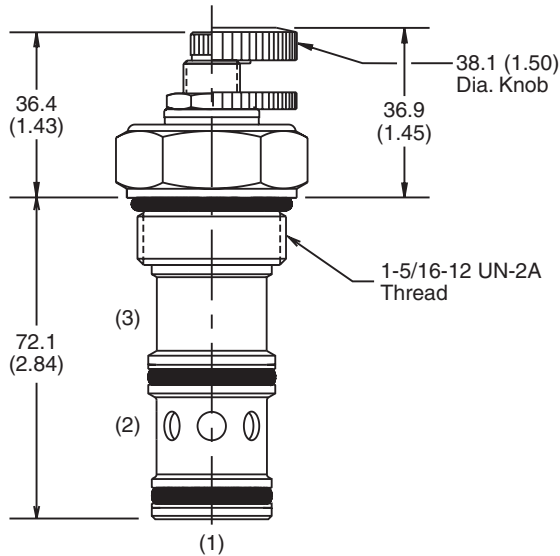

Screw/Knob Version

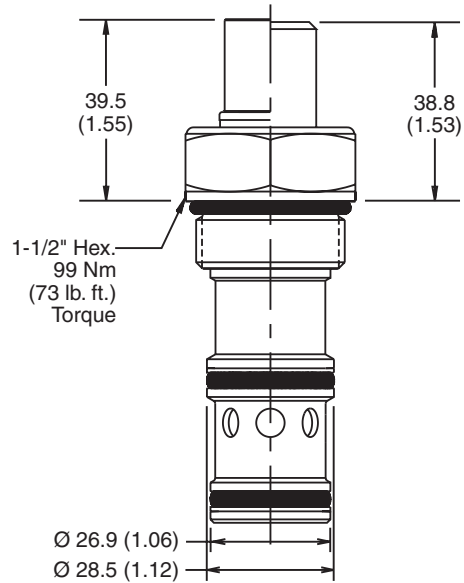

Fixed Cap/Tamper Resistant Version

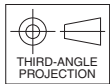

Ordering Information

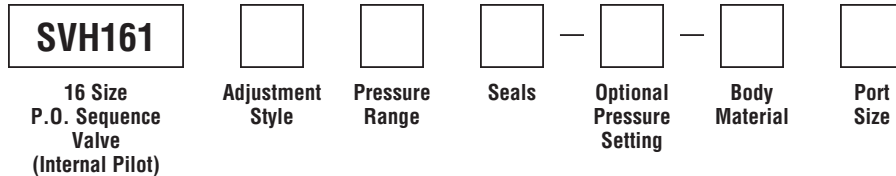

Code	Adjustment Style / Kit No.
F	Fixed style, preset at factory.
K	Knob Adjust (717784-15)
S	Screw Adjust
T	Tamper Resistant Cap (717785)

Code	Seals / Kit No.
Omit	Nitrile / (SK16-3)
V	Fluorocarbon / (SK16-3V)

Code	Body Material
Omit	Steel
A	Aluminum

Code	Pressure Range
10	6.9 - 69 Bar (100 - 1000 PSI) Standard Setting: 34.5 Bar (500 PSI) @ 11.3 LPM (3 GPM)
20	13.8 - 138 Bar (200 - 2000 PSI) Standard Setting: 69 Bar (1000 PSI) @ 11.3 LPM (3 GPM)
30	20.7 - 207 Bar (300 - 3000 PSI) Standard Setting: 103.5 Bar (1500 PSI) @ 11.3 LPM (3 GPM)
50	34.5 - 345 Bar (500 - 5000 PSI) Standard Setting: 172.4 Bar (2500 PSI) @ 11.3 LPM (3 GPM)

Optional Pressure Setting
Pressure \pm 10 i.e. 235 = 2350 PSI (Omit if standard setting is used) Setting Range: 100 to 5000 PSI All settings at 11.3 LPM (3 GPM)

Code	Port Size	Body Part No.
Omit	Cartridge Only	
12T	SAE-12	(B16-3-*12T)
16T	SAE-16	(B16-3-*16T)

* Add "A" for aluminum, omit for steel.

- CV**
Check Valves
- SH**
Shuttle Valves
- LM**
Load/Motor Controls
- FC**
Flow Controls
- PC**
Pressure Controls
- LE**
Logic Elements
- DC**
Directional Controls
- MV**
Manual Valves
- SV**
Solenoid Valves
- PV**
Proportional Valves
- CE**
Coils & Electronics
- BC**
Bodies & Cavities
- TD**
Technical Data

Technical Information

- CV** Check Valves
- SH** Shuttle Valves
- LM** Load/Motor Controls
- FC** Flow Controls
- PC** Pressure Controls
- LE** Logic Elements
- DC** Directional Controls
- MV** Manual Valves
- SV** Solenoid Valves
- PV** Proportional Valves
- CE** Coils & Electronics
- BC** Bodies & Cavities
- TD** Technical Data

General Description

Pilot Operated Sequence Valve (Externally Piloted, Internally Vented). For additional information see Technical Tips on pages PC1-PC6.



Features

- Hardened, precision ground parts for durability
- Low profile adapter for minimal space requirements
- Fully guided poppet for more consistent reseal
- Steel adapters are coated with yellow zinc dichromate for protection from salt spray
- Polyurethane "D"-Ring eliminates backup rings and prevents hydrolysis
- Internal screening protects pilot spring from debris

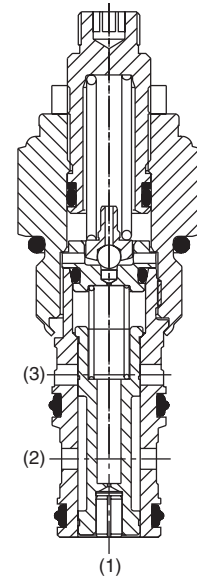
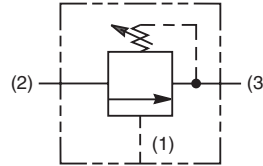
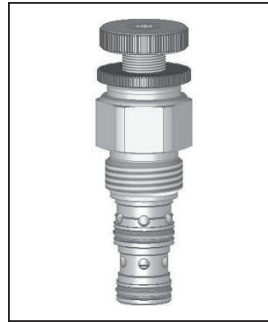

Specifications

Rated Flow	56.3 LPM (15 GPM)
Maximum Inlet Pressure	380 Bar (5500 PSI)
Maximum Pressure Setting	350 Bar (5000 PSI)
Maximum Tank Pressure	350 Bar (5000 PSI)
Maximum Drain Flow	See maximum drain flow chart (Lower right)
Reseat Pressure	90% of crack pressure
Leakage at 150 SSU (32 cSt)	82 cc/min. (5 cu. in./min.) @ 210 Bar (3000 PSI)
Cartridge Material	All parts steel. All operating parts hardened steel.
Operating Temp. Range/Seals	-45°C to +93.3°C ("D"-Ring) (-50°F to +200°F) -31.7°C to +121.1°C (Fluorocarbon) (-25°F to +250°F)
Fluid Compatibility/Viscosity	Mineral-based or synthetic with lubricating properties at viscosities of 45 to 2000 SSU (6 to 420 cSt)
Filtration	ISO Code 16/13, SAE Class 4 or better
Approx. Weight	.45 kg (1.0 lbs.)
Cavity	C10-3 (See BC Section for more details)
Form Tool	Rougher NTF10-3R Finisher NTF10-3F

Performance Curve
Flow vs. Inlet Pressure

(Pressure rise through cartridge only)

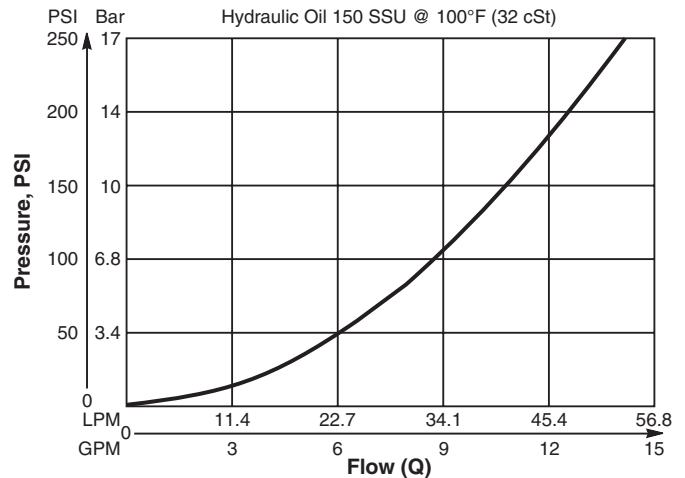

Maximum Drain Flow

P_{PILOT} - P_{SETTING}	Drain Flow
6.9 Bar (100 PSI)	0.34 LPM (0.09 GPM)
35 Bar (500 PSI)	0.76 LPM (0.20 GPM)
69 Bar (1000 PSI)	1.08 LPM (0.29 GPM)
138 Bar (2000 PSI)	1.53 LPM (0.40 GPM)
207 Bar (3000 PSI)	1.87 LPM (0.50 GPM)

Dimensions Millimeters (Inches)

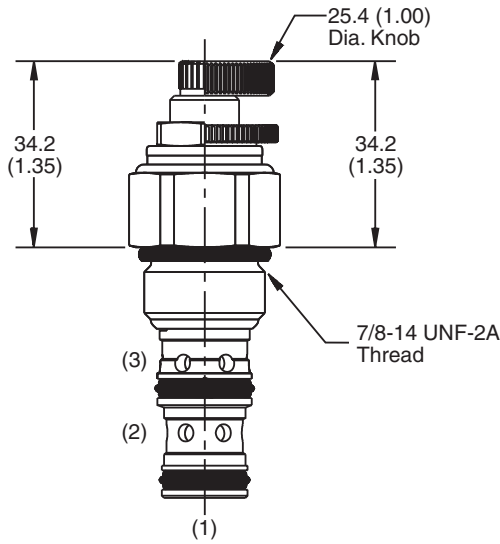

Screw/Knob Version

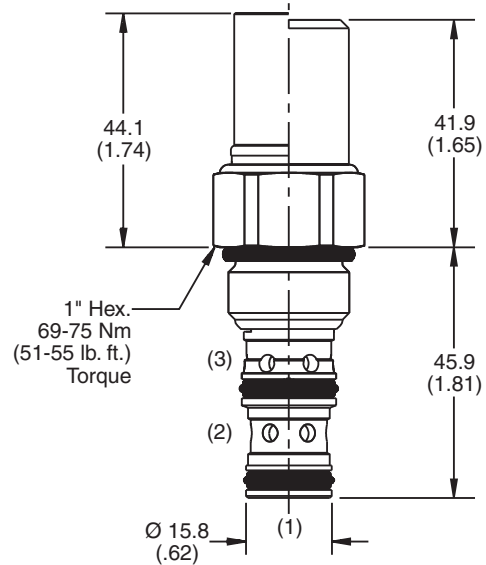

Fixed Cap/Tamper Resistant Version

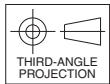

Ordering Information

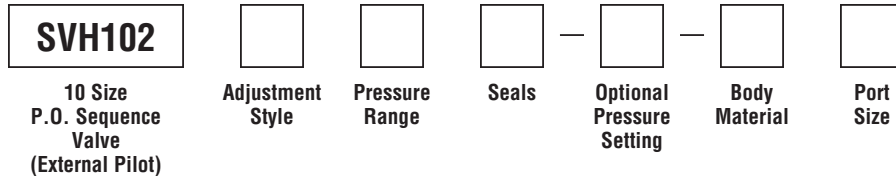

Code	Adjustment Style / Kit No.
F	Fixed style, preset at factory.
K	Knob Adjust (717784-10)
S	Screw Adjust
T	Tamper Resistant Cap (718083)

Code	Seals / Kit No.
Omit	"D"-Ring / (SK10-3)
N	Nitrile / (SK10-3N)
V	Fluorocarbon / (SK10-3V)

Code	Body Material
Omit	Steel
A	Aluminum

Code	Pressure Range
10	6.9 - 69 Bar (100 - 1000 PSI) Standard Setting: 34.5 Bar (500 PSI) @ crack pressure, approximately 11.3 LPM (3 GPM)
20	6.9 - 138 Bar (100 - 2000 PSI) Standard Setting: 69 Bar (1000 PSI) @ crack pressure, approximately 11.3 LPM (3 GPM)
30	13.8 - 207 Bar (200 - 3000 PSI) Standard Setting: 103.5 Bar (1500 PSI) @ crack pressure, approximately 11.3 LPM (3 GPM)
50	13.8 - 345 Bar (200 - 5000 PSI) Standard Setting: 172.4 Bar (2500 PSI) @ crack pressure, approximately 11.3 LPM (3 GPM)

Optional Pressure Setting
Pressure \pm 10 i.e. 235 = 2350 PSI (Omit if standard setting is used) Setting Range: 100 to 5000 PSI All settings at crack pressure, approximately 11.3 LPM (3 GPM)

Code	Port Size	Body Part No.
Omit	Cartridge Only	
4P	1/4" NPTF	(B10-3-*4P)
6P	3/8" NPTF	(B10-3-*6P)
8P	1/2" NPTF	(B10-3-*8P)
6T	SAE-6	(B10-3-*6T)
8T	SAE-8	(B10-3-*8T)
6B	3/8" BSPG	(B10-3-6B)†
8B	1/2" BSPG	(B10-3-*8B)

* Add "A" for aluminum, omit for steel.
 † Steel body only.

Technical Information

- CV** Check Valves
- SH** Shuttle Valves
- LM** Load/Motor Controls
- FC** Flow Controls
- PC** Pressure Controls
- LE** Logic Elements
- DC** Directional Controls
- MV** Manual Valves
- SV** Solenoid Valves
- PV** Proportional Valves
- CE** Coils & Electronics
- BC** Bodies & Cavities
- TD** Technical Data

General Description

Pilot Operated Sequence Valve (Externally Piloted, Internally Vented). For additional information see Technical Tips on pages PC1-PC6.

Features

- Hardened, precision ground parts for durability
- High accuracy, pilot operation design
- Ball-type pilot for added stability
- All external parts have yellow zinc dichromate. This coating is ideal for salt spray applications.

Specifications

Rated Flow	151.6 LPM (40 GPM)
Maximum Inlet Pressure	380 Bar (5500 PSI)
Maximum Pressure Setting	350 Bar (5000 PSI)
Maximum Tank Pressure	350 Bar (5000 PSI)
Maximum Drain Flow	See maximum drain flow chart (Lower right)
Reseat Pressure	80% of Crack Pressure
Leakage at 150 SSU (32 cSt)	82 cc/min. (5 cu. in./min.) @ 75% of Crack Pressure
Cartridge Material	All parts steel. All operating parts hardened steel.
Operating Temp. Range/Seals	-40°C to +93.3°C (Nitrile) (-40°F to +200°F) -31.7°C to +121.1°C (Fluorocarbon) (-25°F to +250°F)
Fluid Compatibility/Viscosity	Mineral-based or synthetic with lubricating properties at viscosities of 45 to 2000 SSU (6 to 420 cSt)
Filtration	ISO Code 16/13, SAE Class 4 or better
Approx. Weight	.45 kg (1.0 lbs.)
Cavity	C16-3 (See BC Section for more details)
Form Tool	Rougher NFT16-3R Finisher NFT16-3F

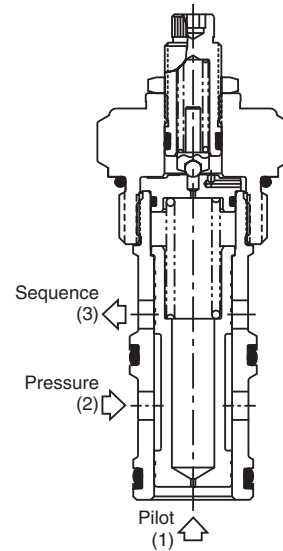
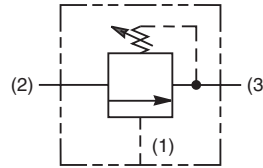

Performance Curve

Flow vs. Inlet Pressure

(Pressure rise through cartridge only)

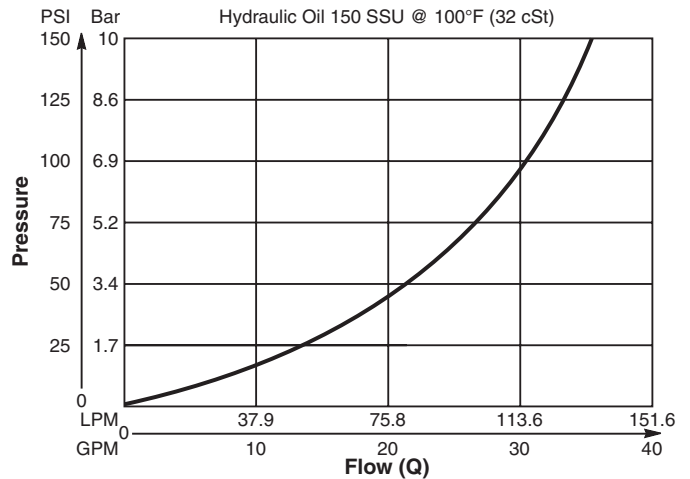

Maximum Drain Flow

P_{PILOT} - P_{SETTING}	Drain Flow
6.9 Bar (100 PSI)	0.69 LPM (0.18 GPM)
35 Bar (500 PSI)	1.55 LPM (0.41 GPM)
69 Bar (1000 PSI)	2.19 LPM (0.58 GPM)
138 Bar (2000 PSI)	3.10 LPM (0.82 GPM)
207 Bar (3000 PSI)	3.79 LPM (1.00 GPM)

Dimensions Millimeters (Inches)

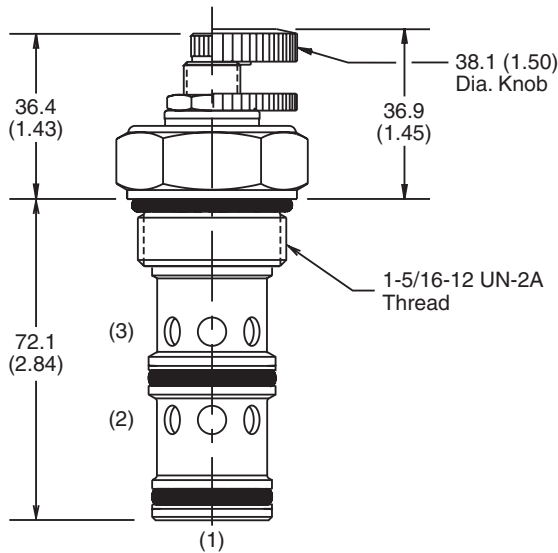

Screw/Knob Version

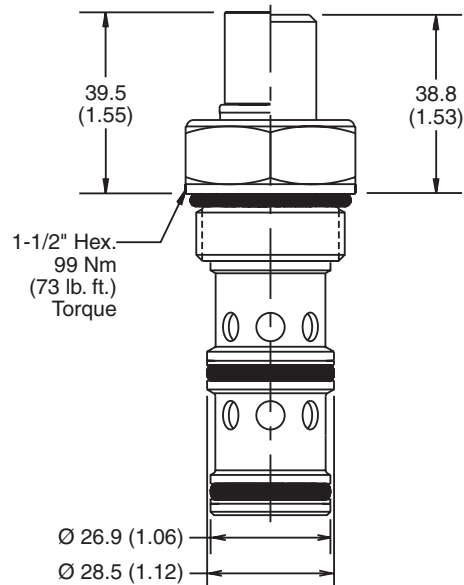

Fixed Cap/Tamper Resistant Version

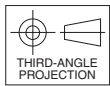

Screw/Knob Version

Fixed Cap/Tamper Resistant Version

Ordering Information

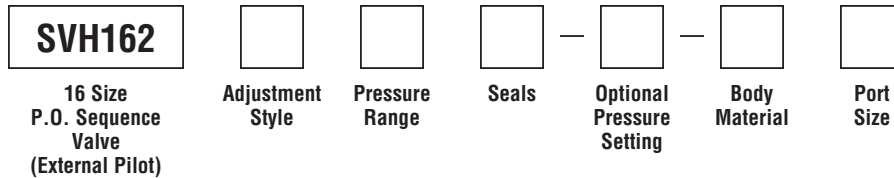

Code	Adjustment Style / Kit No.
F	Fixed style, preset at factory.
K	Knob Adjust (717784-15)
S	Screw Adjust
T	Tamper Resistant Cap (717785)

Code	Seals / Kit No.
Omit	Nitrile / (SK16-3)
V	Fluorocarbon / (SK16-3V)

Code	Body Material
Omit	Steel
A	Aluminum

Code	Pressure Range
10	6.9 - 69 Bar (100 - 1000 PSI) Standard Setting: 34.5 Bar (500 PSI) @ 11.3 LPM (3 GPM)
20	13.8 - 138 Bar (200 - 2000 PSI) Standard Setting: 69 Bar (1000 PSI) @ 11.3 LPM (3 GPM)
30	20.7 - 207 Bar (300 - 3000 PSI) Standard Setting: 103.5 Bar (1500 PSI) @ 11.3 LPM (3 GPM)
50	34.5 - 345 Bar (500 - 5000 PSI) Standard Setting: 172.4 Bar (2500 PSI) @ 11.3 LPM (3 GPM)

Optional Pressure Setting
Pressure ÷ 10 i.e. 235 = 2350 PSI (Omit if standard setting is used) Setting Range: 100 to 5000 PSI All settings at 11.3 LPM (3 GPM)

Code	Port Size	Body Part No.
Omit	Cartridge Only	
12T	SAE-12	(B16-3-*12T)
16T	SAE-16	(B16-3-*16T)

* Add "A" for aluminum, omit for steel.

- CV** Check Valves
- SH** Shuttle Valves
- LM** Load/Motor Controls
- FC** Flow Controls
- PC** Pressure Controls
- LE** Logic Elements
- DC** Directional Controls
- MV** Manual Valves
- SV** Solenoid Valves
- PV** Proportional Valves
- CE** Coils & Electronics
- BC** Bodies & Cavities
- TD** Technical Data

Technical Information

- CV** Check Valves
- SH** Shuttle Valves
- LM** Load/Motor Controls
- FC** Flow Controls
- PC** Pressure Controls
- LE** Logic Elements
- DC** Directional Controls
- MV** Manual Valves
- SV** Solenoid Valves
- PV** Proportional Valves
- CE** Coils & Electronics
- BC** Bodies & Cavities
- TD** Technical Data

General Description

Pilot Operated Sequence Valve with Reverse Flow Check. For additional information see Technical Tips on pages PC1-PC6.



Features

- Hardened, precision ground parts for durability
- Built-in reverse flow check reduces plumbing
- Cartridge design
- All external parts have yellow zinc dichromate. This coating is ideal for salt spray applications.

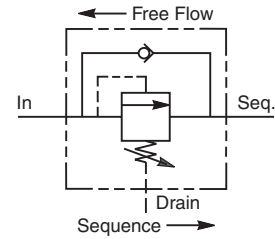
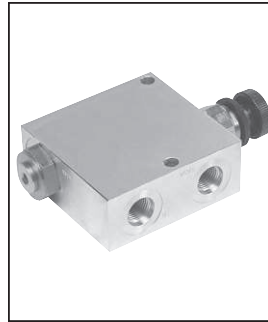

Specifications

Rated Flow	56.3 LPM (15 GPM)
Maximum Inlet Pressure	380 Bar (5500 PSI)
Maximum Pressure Setting	350 Bar (5000 PSI)
Maximum Drain Flow	.94 LPM (0.25 GPM)
Reseat Pressure	90% of Crack Pressure
Leakage at 150 SSU (32 cSt)	82 cc/min. (5 cu. in./min.) at 210 Bar (3000 PSI)
Cartridge Material	All parts steel. All operating parts hardened steel.
Body Material	Steel
Operating Temp. Range/Seals	-45°C to +93.3°C ("D"-Ring) (-50°F to +200°F) -31.7°C to +121.1°C (Fluorocarbon) (-25°F to +250°F)
Fluid Compatibility/Viscosity	Mineral-based or synthetic with lubricating properties at viscosities of 45 to 2000 SSU (6 to 420 cSt)
Filtration	ISO Code 16/13, SAE Class 4 or better
Approx. Weight	1.6 kg (3.5 lbs.)

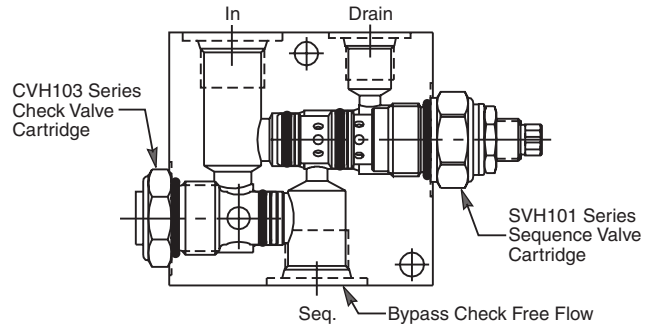

Performance Curve

Flow vs. Inlet Pressure

(Pressure rise through cartridge only)

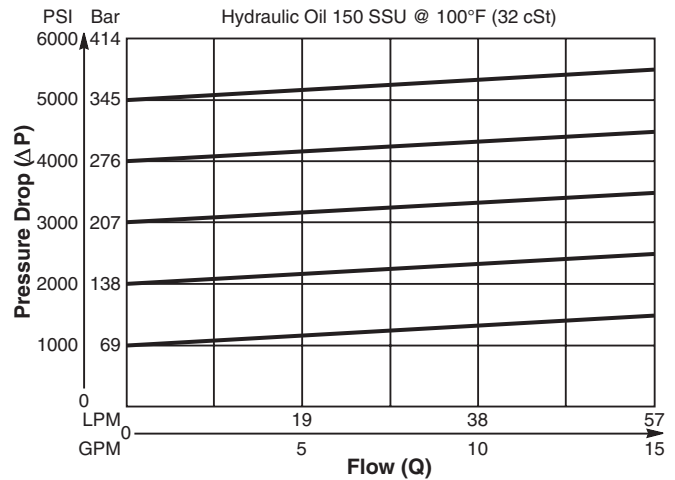

Dimensions Millimeters (Inches)

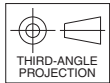
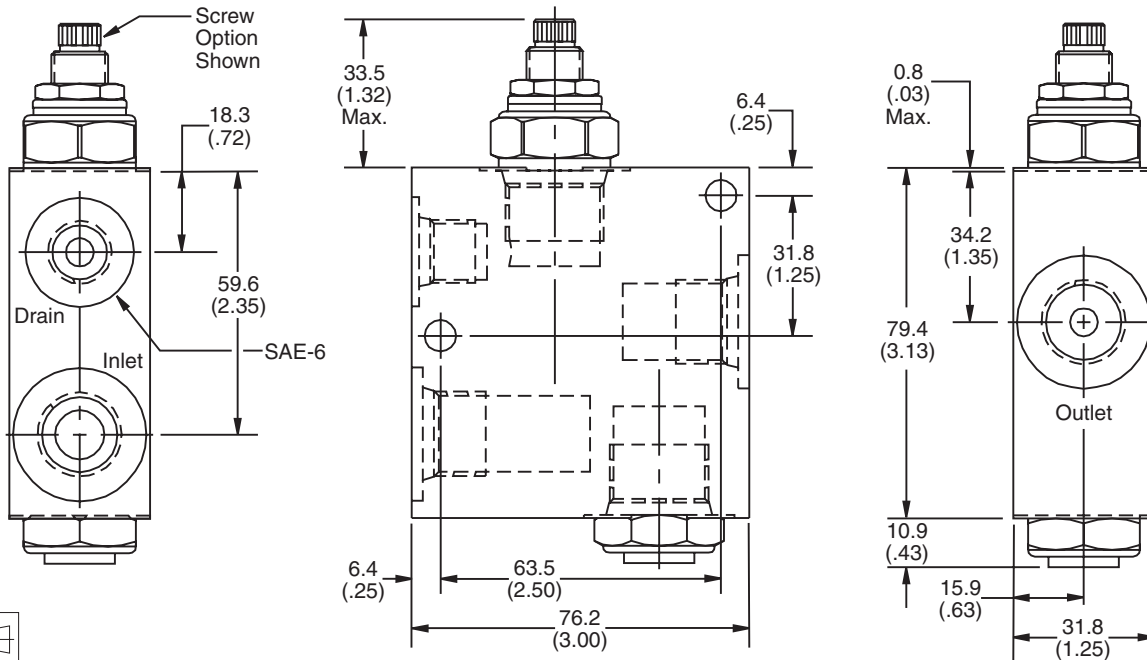

Ordering Information

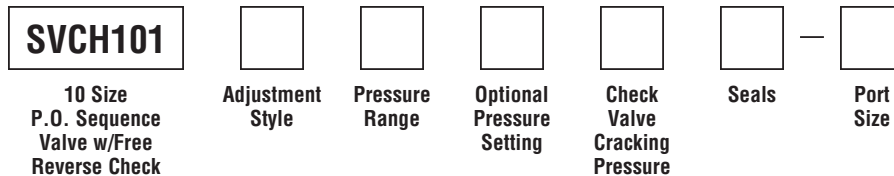

Code	Adjustment Style / Kit No.
F	Fixed style, preset at factory.
K	Knob Adjust (717784-10)
S	Screw Adjust
T	Tamper Resistant Cap (718083)

Optional Pressure Setting	
Pressure ± 10 i.e. 235 = 2350 PSI (Omit if standard setting is used) Setting Range: 100 to 5000 PSI All settings at crack pressure, approximately .95 LPM (.25 GPM)	

Code	Seals
Omit	"D"-Ring
N	Nitrile
V	Fluorocarbon

Code	Port Size	Part No.
8T	SAE-8	830343

Code	Pressure Range
10	6.9 - 69 Bar (100 - 1000 PSI) Standard Setting: 34.5 Bar (500 PSI) @ crack pressure, approximately .95 LPM (.25 GPM)
20	6.9 - 138 Bar (100 - 2000 PSI) Standard Setting: 69 Bar (1000 PSI) @ crack pressure, approximately .95 LPM (.25 GPM)
30	13.8 - 207 Bar (200 - 3000 PSI) Standard Setting: 103.5 Bar (1500 PSI) @ crack pressure, approximately .95 LPM (.25 GPM)
50	13.8 - 345 Bar (200 - 5000 PSI) Standard Setting: 172.4 Bar (2500 PSI) @ crack pressure, approximately .95 LPM (.25 GPM)

Code	Cracking Pressure
Omit	0.3 Bar (5 PSI)
P20	1.4 Bar (20 PSI)
P50	3.5 Bar (50 PSI)
P65	4.5 Bar (65 PSI)
P100	6.9 Bar (100 PSI)

Technical Information

- CV** Check Valves
- SH** Shuttle Valves
- LM** Load/Motor Controls
- FC** Flow Controls
- PC** Pressure Controls
- LE** Logic Elements
- DC** Directional Controls
- MV** Manual Valves
- SV** Solenoid Valves
- PV** Proportional Valves
- CE** Coils & Electronics
- BC** Bodies & Cavities
- TD** Technical Data

General Description

Pilot Operated Sequence Valve with Reverse Flow Check. For additional information see Technical Tips on pages PC1-PC6.

Features

- High flow capacity
- For use on clamp and drill circuits where pressure is to be maintained regardless of drop in system pressure
- Integral 250 micron pilot flow filter
- Hardened working parts for maximum durability
- Adjustable and tamperproof versions available
- All external parts zinc plated

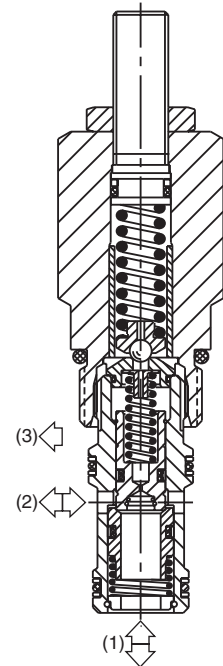
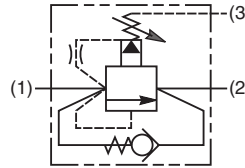
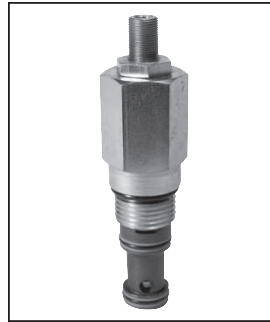

Specifications

Rated Flow	70 LPM (18.5 GPM)
Maximum Inlet Pressure	420 Bar (6000 PSI)
Maximum Pressure Setting	H - 10-210 Bar (145-3000 PSI) P - 10-420 Bar (145-6000 PSI)
Maximum Tank Pressure	420 Bar (6000 PSI)
Leakage at 150 SSU (32 cSt)	50 drops/min. @ 100 Bar (1450 PSI)
Cartridge Material	All parts steel. All operating parts hardened steel.
Operating Temp. Range/Seals	-40°C to +93.3°C (Nitrile) (-40°F to +200°F) -31.7°C to +121.1°C (Fluorocarbon) (-25°F to +250°F)
Fluid Compatibility/Viscosity	Mineral-based or synthetic with lubricating properties at viscosities of 45 to 2000 SSU (6 to 420 cSt)
Filtration	ISO Code 16/13, SAE Class 4 or better
Approx. Weight	0.25 kg (0.55 lbs.)
Cavity	C10-3S (See BC Section for more details)
Form Tool	Rougher NFT10S-3R Finisher NFT10S-3F

Performance Curve

(Pressure rise through cartridge only)

Flow vs. Inlet Pressure 1 to 2

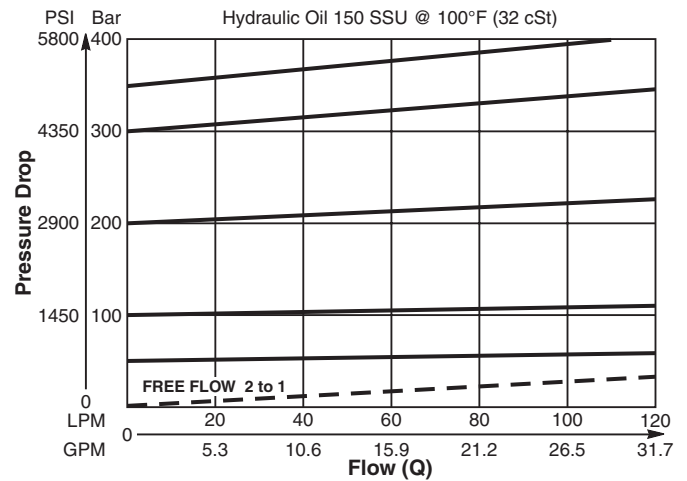

Application

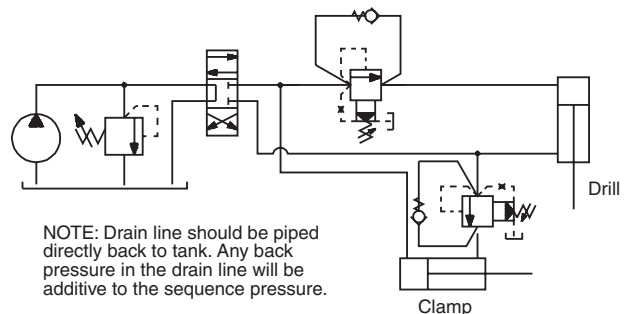

Dimensions Millimeters (Inches)

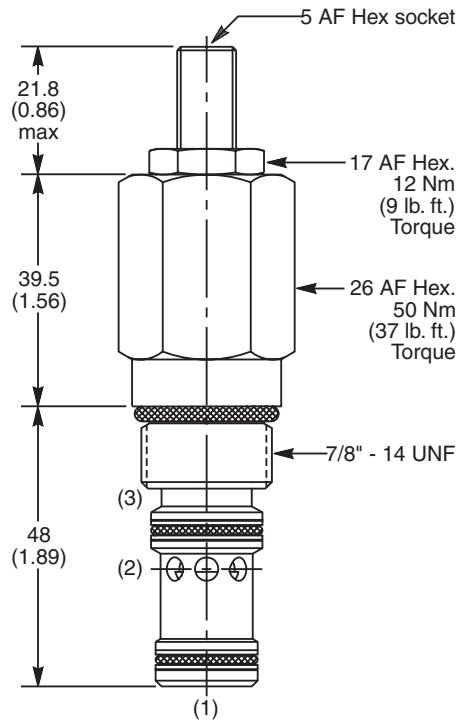

Ordering Information

B04D3	<input type="checkbox"/>	<input type="checkbox"/>	<input type="checkbox"/>	<input type="checkbox"/>	<input type="checkbox"/>
10 Size Pilot Operated Sequence Valve	Pressure Adjustment Range	Adjustment Style	Optional Pressure Setting	Seals	

Code	Pressure Adjustment Range
H	10 - 210 Bar (145 - 3000 PSI)
P	10 - 420 Bar (145 - 6000 PSI)

Optional Pressure Setting	
Specify setting if required (Bar)	
B04D3H Standard Setting: 100 Bar (1450 PSI) @ 15 LPM (4.0 GPM)	
B04D3P Standard Setting: 200 Bar (2900 PSI) @ 15 LPM (4.0 GPM)	

Code	Adjustment Style / Kit No.
Z	Screw Adjust (Std.)
W	Knob Adjust
T	Tamper Resistant Cap (TC1130)

Code	Seals / Kit No.
N	Nitrile, Buna-N (Std.) / (SK30504N-1)
V	Fluorocarbon / (SK30504V-1)

Order Bodies Separately

LB10	<input type="checkbox"/>	<input type="checkbox"/>
Line Body	Porting	Body Material

Code	Porting
710	5/8" SAE (main) 3/8" SAE (aux)
711	3/4" BSP (main) 1/4" BSP (aux)

Code	Body Material
A	Aluminum
S	Steel

- CV**
Check Valves
- SH**
Shuttle Valves
- LM**
Load/Motor Controls
- FC**
Flow Controls
- PC**
Pressure Controls
- LE**
Logic Elements
- DC**
Directional Controls
- MV**
Manual Valves
- SV**
Solenoid Valves
- PV**
Proportional Valves
- CE**
Coils & Electronics
- BC**
Bodies & Cavities
- TD**
Technical Data

Technical Information

- CV** Check Valves
- SH** Shuttle Valves
- LM** Load/Motor Controls
- FC** Flow Controls
- PC** Pressure Controls
- LE** Logic Elements
- DC** Directional Controls
- MV** Manual Valves
- SV** Solenoid Valves
- PV** Proportional Valves
- CE** Coils & Electronics
- BC** Bodies & Cavities
- TD** Technical Data

General Description

Kick-Down, Spool Type, Pilot Operated Sequence Valve. For additional information see Technical Tips on pages PC1-PC6.

Features

- High flow capacity
- Integral 250 micron pilot flow filter
- Hardened working parts for maximum durability
- Adjustable and tamperproof versions available
- All external parts zinc plated

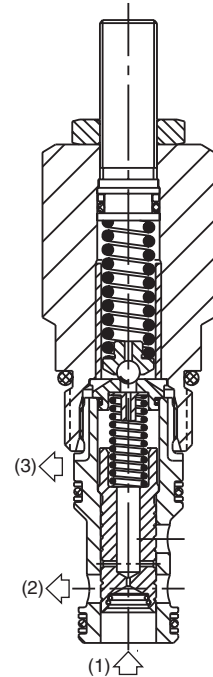
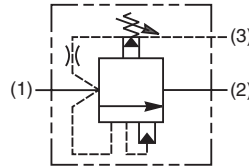
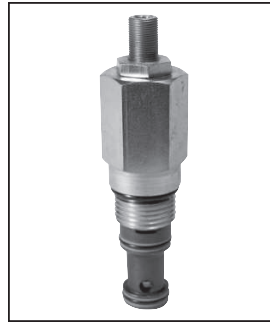

Specifications

Rated Flow	160 LPM (42 GPM)
Maximum Inlet Pressure	420 Bar (6000 PSI)
Maximum Pressure Setting	H - 10-210 Bar (145-3000 PSI) P - 10-420 Bar (145-6000 PSI)
Maximum Tank Pressure	420 Bar (6000 PSI)
Sensitivity: Pressure/Turn	H - 30 Bar (435 PSI) P - 55 Bar (800 PSI)
Cartridge Material	All parts steel. All operating parts hardened steel.
Operating Temp. Range/Seals	-40°C to +93.3°C (Nitrile) (-40°F to +200°F) -31.7°C to +121.1°C (Fluorocarbon) (-25°F to +250°F)
Fluid Compatibility/Viscosity	Mineral-based or synthetic with lubricating properties at viscosities of 45 to 2000 SSU (6 to 420 cSt)
Filtration	ISO Code 16/13, SAE Class 4 or better
Approx. Weight	0.27 kg (0.55 lbs.)
Cavity	C10-3S (See BC Section for more details)
Form Tool	Rougher NFT10S-3R Finisher NFT10S-3F

Performance Curve

(Pressure rise through cartridge only)

Pressure Drop vs. Flow 1 to 2

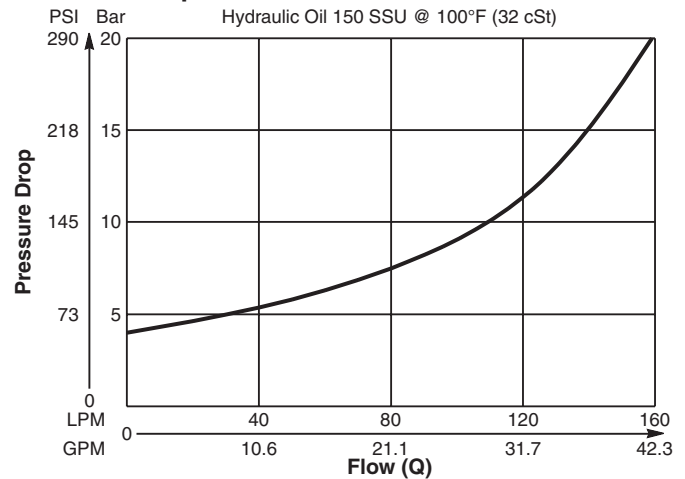

Application Note

Valve unloads completely when setting is reached and resets when fluid supply is removed.

Dimensions Millimeters (Inches)

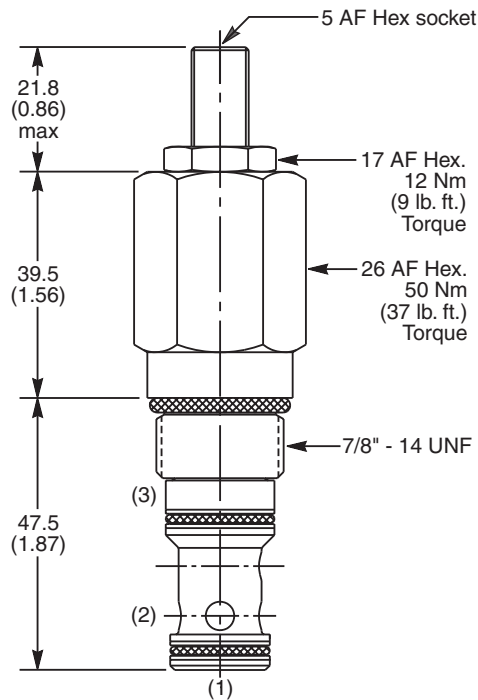

Ordering Information

B04C3	<input type="checkbox"/>	<input type="checkbox"/>	<input type="checkbox"/>	<input type="checkbox"/>	<input type="checkbox"/>
10 Size Kick-Down Pilot Operated Sequence Valve	Pressure Adjustment Range	Adjustment Style	Optional Pressure Setting	Seals	

Code	Pressure Adjustment Range
H	10 - 210 Bar (145 - 3000 PSI)
P	10 - 420 Bar (145 - 6000 PSI)

Optional Pressure Setting	
Specify setting if required (Bar)	
B04C3H Standard Setting: 100 Bar (1450 PSI)	
B04C3P Standard Setting: 200 Bar (2900 PSI)	

Code	Adjustment Style / Kit No.
Z	Screw Adjust (Std.)
W	Knob Adjust
T	Tamper Resistant Cap (TC1130)

Code	Seals / Kit No.
N	Nitrile, Buna-N (Std.) / (SK30504N-1)
V	Fluorocarbon / (SK30504V-1)

Order Bodies Separately

LB10	<input type="checkbox"/>	<input type="checkbox"/>
Line Body	Porting	Body Material

Code	Porting
710	5/8" SAE (main) 3/8" SAE (aux)
711	3/4" BSP (main) 1/4" BSP (aux)

Code	Body Material
A	Aluminum
S	Steel

- CV**
Check Valves
- SH**
Shuttle Valves
- LM**
Load/Motor Controls
- FC**
Flow Controls
- PC**
Pressure Controls
- LE**
Logic Elements
- DC**
Directional Controls
- MV**
Manual Valves
- SV**
Solenoid Valves
- PV**
Proportional Valves
- CE**
Coils & Electronics
- BC**
Bodies & Cavities
- TD**
Technical Data

Technical Information

- CV** Check Valves
- SH** Shuttle Valves
- LM** Load/Motor Controls
- FC** Flow Controls
- PC** Pressure Controls
- LE** Logic Elements
- DC** Directional Controls
- MV** Manual Valves
- SV** Solenoid Valves
- PV** Proportional Valves
- CE** Coils & Electronics
- BC** Bodies & Cavities
- TD** Technical Data

General Description

Direct Acting Sequence Valve with Internal Pilot and Drain. For additional information see Technical Tips on pages PC1-PC6.

Features

- Hardened working parts for maximum durability
- All external parts zinc plated
- Adjustable and tamperproof versions available

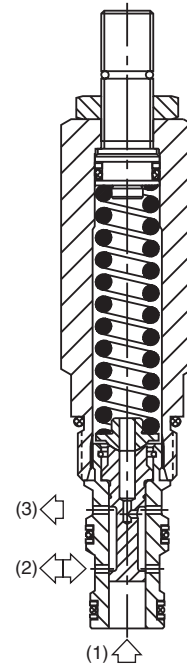
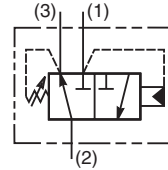
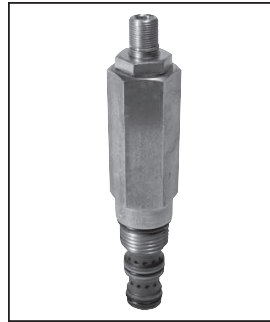

Specifications

Rated Flow	30 LPM (8 GPM)
Maximum Inlet Pressure	420 Bar (6000 PSI)
Maximum Pressure Setting	2-148 Bar (30-2150 PSI)
Maximum Tank Pressure	420 Bar (6000 PSI)
Leakage at 150 SSU (32 cSt)	25 ml/min. @ 35 Bar (580 PSI)
Cartridge Material	All parts steel. All operating parts hardened steel.
Operating Temp. Range/Seals	-40°C to +93.3°C (Nitrile) (-40°F to +200°F) -31.7°C to +121.1°C (Fluorocarbon) (-25°F to +250°F)
Fluid Compatibility/Viscosity	Mineral-based or synthetic with lubricating properties at viscosities of 45 to 2000 SSU (6 to 420 cSt)
Filtration	ISO Code 16/13, SAE Class 4 or better
Approx. Weight	0.21 kg (0.46 lbs.)
Cavity	C08-3 (See BC Section for more details)
Form Tool	Rougher NFT08-3R Finisher NFT08-3F

Performance Curves

(Pressure rise through cartridge only)

Flow vs. Inlet Pressure 1 to 2

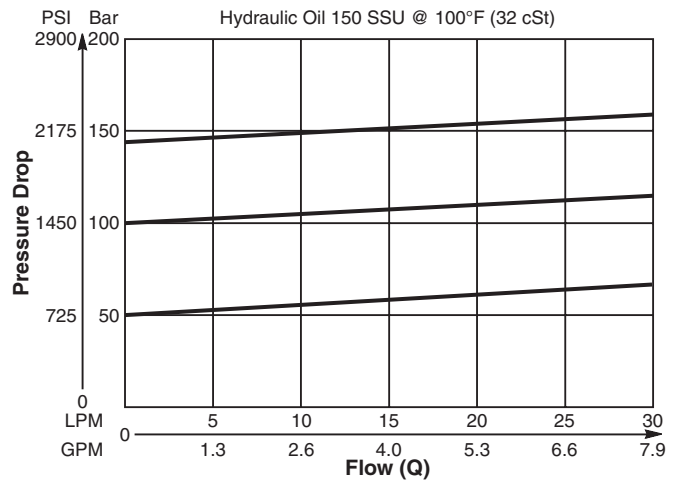

Pressure Drop vs. Flow

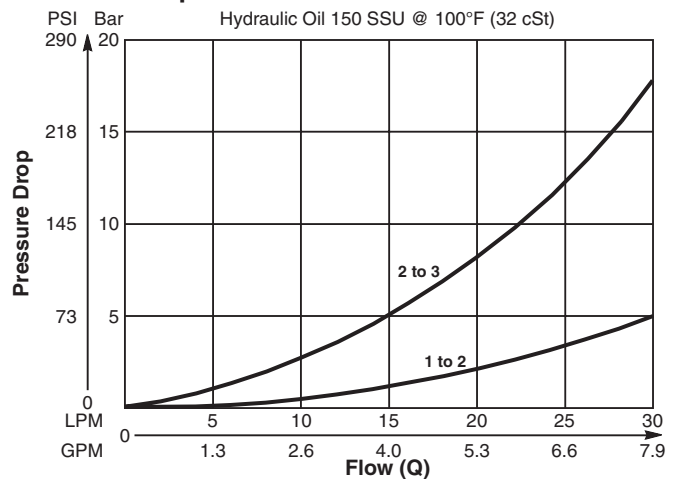

Dimensions Millimeters (Inches)

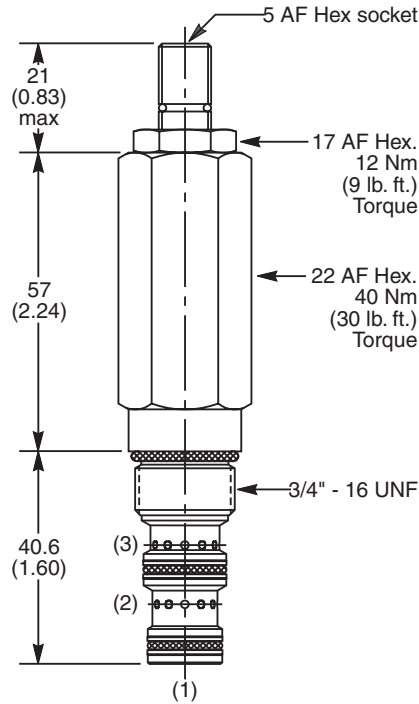

Ordering Information

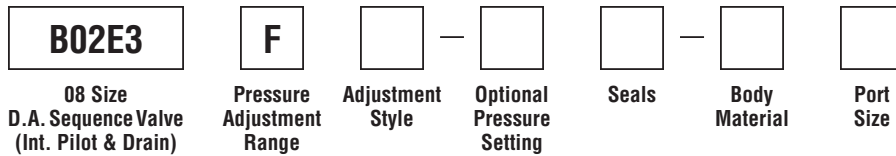

Code	Pressure Adjustment Range
F	2 - 148 Bar (30 - 2150 PSI)

Code	Seals / Kit No.
N	Nitrile, Buna-N (Std.) / (SK30501N-1)
V	Fluorocarbon / (SK30501V-1)

Code	Body Material
Omit	Steel
A	Aluminum

Code	Adjustment Style / Kit No.
Z	Screw Adjust (Std.)
W	Knob Adjust
T	Tamper Resistant Cap (TC1130)

Code	Port Size	Body Part No.
Omit	Cartridge Only	
4P	1/4" NPTF	(B08-3-*4P)
4T	SAE-4	(B08-3-*4T)
6T	SAE-6	(B08-3-*6T)
6B	3/8" BSPG	(B08-3-*6B)

Optional Pressure Setting	
Specify setting if required (Bar)	
B02E3F Standard Setting: 75 Bar (1100 PSI) @ 5 LPM (1.3 GPM)	

* Add "A" for aluminum, omit for steel.

- CV**
Check Valves
- SH**
Shuttle Valves
- LM**
Load/Motor Controls
- FC**
Flow Controls
- PC**
Pressure Controls
- LE**
Logic Elements
- DC**
Directional Controls
- MV**
Manual Valves
- SV**
Solenoid Valves
- PV**
Proportional Valves
- CE**
Coils & Electronics
- BC**
Bodies & Cavities
- TD**
Technical Data

Technical Information

- CV** Check Valves
- SH** Shuttle Valves
- LM** Load/Motor Controls
- FC** Flow Controls
- PC** Pressure Controls
- LE** Logic Elements
- DC** Directional Controls
- MV** Manual Valves
- SV** Solenoid Valves
- PV** Proportional Valves
- CE** Coils & Electronics
- BC** Bodies & Cavities
- TD** Technical Data

General Description

Direct Acting Sequence Valve with Internal Pilot and Drain. For additional information see Technical Tips on pages PC1-PC6.

Features

- Hardened working parts for maximum durability
- All external parts zinc plated
- Adjustable and tamperproof versions available

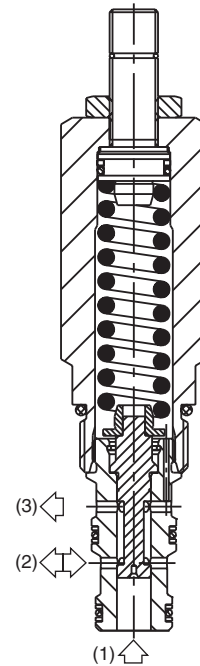
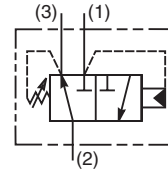
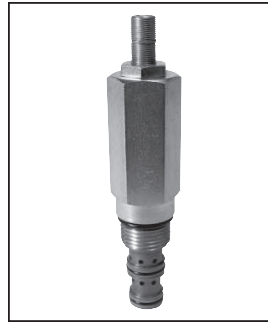

Specifications

Rated Flow	50 LPM (13 GPM)
Maximum Inlet Pressure	420 Bar (6000 PSI)
Maximum Pressure Setting	E - 2-80 Bar (30-1160 PSI) G - 2-166 Bar (30-2400 PSI)
Maximum Tank Pressure	420 Bar (6000 PSI)
Leakage at 150 SSU (32 cSt)	25 ml/min. @ 60 Bar (870 PSI)
Cartridge Material	All parts steel. All operating parts hardened steel.
Operating Temp. Range/Seals	-40°C to +93.3°C (Nitrile) (-40°F to +200°F) -31.7°C to +121.1°C (Fluorocarbon) (-25°F to +250°F)
Fluid Compatibility/Viscosity	Mineral-based or synthetic with lubricating properties at viscosities of 45 to 2000 SSU (6 to 420 cSt)
Filtration	ISO Code 16/13, SAE Class 4 or better
Approx. Weight	0.27 kg (0.60 lbs.)
Cavity	C10-3 (See BC Section for more details)
Form Tool	Rougher NFT10-3R Finisher NFT10-3F

Performance Curves

(Pressure rise through cartridge only)

Flow vs. Inlet Pressure 1 to 2

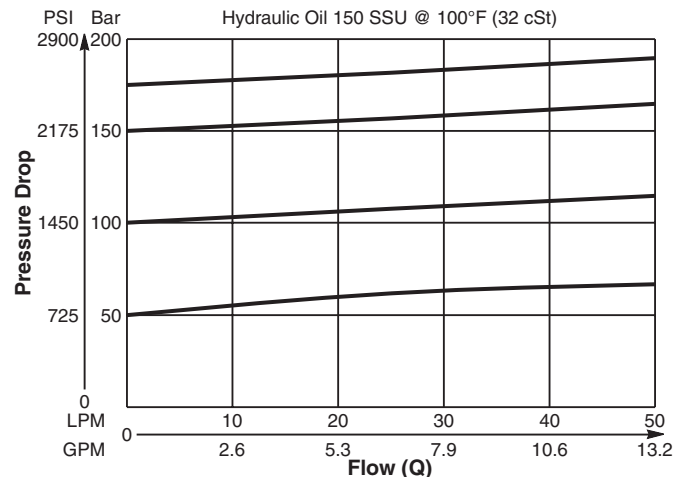

Pressure Drop vs. Flow 1 to 2 and 2 to 3

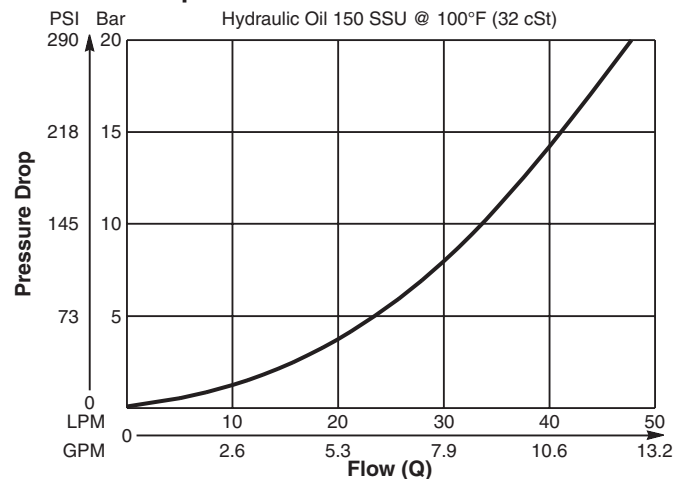

Dimensions Millimeters (Inches)

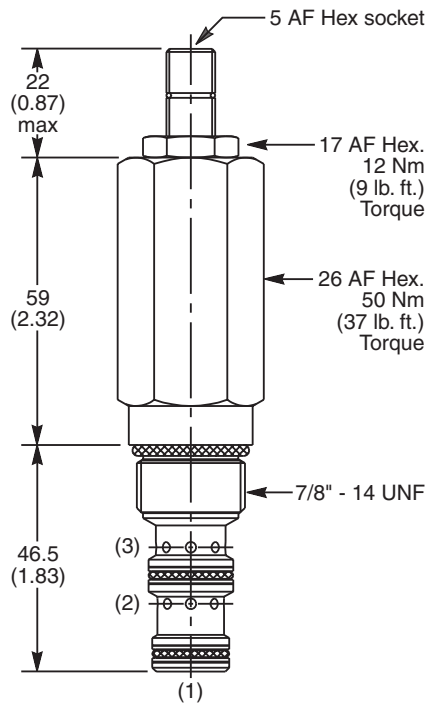

Ordering Information

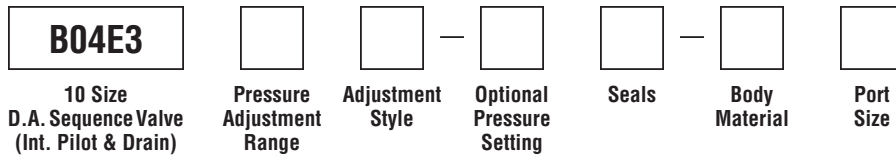

Code	Pressure Adjustment Range
E	2 - 80 Bar (30 - 1160 PSI)
G	2 - 166 Bar (30 - 2400 PSI)
J	40 - 240 Bar (580 - 3500 PSI)

Code	Seals / Kit No.
N	Nitrile, Buna-N (Std.) / (SK30505N-1)
V	Fluorocarbon / (SK30505V-1)

Code	Body Material
Omit	Steel
A	Aluminum

Code	Adjustment Style / Kit No.
Z	Screw Adjust (Std.)
W	Knob Adjust
T	Tamper Resistant Cap (TC1130)

Code	Port Size	Body Part No.
Omit	Cartridge Only	
4P	1/4" NPTF	(B10-3-*4P)
6P	3/8" NPTF	(B10-3-*6P)
8P	1/2" NPTF	(B10-3-*8P)
6T	SAE-6	(B10-3-*6T)
8T	SAE-8	(B10-3-*8T)
6B	3/8" BSPG	(B10-3-6B)†
8B	1/2" BSPG	(B10-3-*8P)

Optional Pressure Setting	
Specify setting if required (Bar)	
B04E3E	Standard Setting: 40 Bar (580 PSI) @ 5 LPM (1.3 GPM)
B04E3G	Standard Setting: 80 Bar (1160 PSI) @ 5 LPM (1.3 GPM)
B04E3J	Standard Setting: 120 Bar (1750 PSI) @ 5 LPM (1.3 GPM)

* Add "A" for aluminum, omit for steel.
 † Steel body only.

Technical Information

- CV** Check Valves
- SH** Shuttle Valves
- LM** Load/Motor Controls
- FC** Flow Controls
- PC** Pressure Controls
- LE** Logic Elements
- DC** Directional Controls
- MV** Manual Valves
- SV** Solenoid Valves
- PV** Proportional Valves
- CE** Coils & Electronics
- BC** Bodies & Cavities
- TD** Technical Data

General Description

Direct Acting Sequence Valve (Internally Piloted, Externally Drained). In the steady state condition, all three ports are blocked with the spring chamber drained to port 3. When the pressure at port 1 exceeds the valve setting, the spool moves allowing flow from the nose of the cartridge (port 1) to the actuator port (port 2). By externally draining the spring chamber directly to tank (port 3), the valve is insensitive to back pressure at the sequence port.

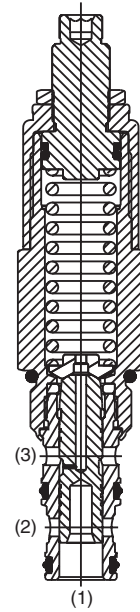
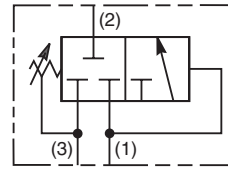

Features

- Hardened, precision ground parts for durability
- Internal mechanical stop limits spool travel eliminating spring solidification
- “D”-Ring eliminates backup rings
- All external parts have yellow zinc dichromate. This coating is ideal for salt spray applications.
- Fast response

Specifications

Flow Rate	56 LPM (15 GPM)
Maximum Inlet Pressure	250 Bar (3600 PSI)
Maximum Pressure Setting	138 Bar (2000 PSI)
Leakage at 150 SSU (32 cSt)	82 cc/min. (5 cu. in./min.) at 210 Bar (3000 PSI)
Cartridge Material	All parts steel. All operating parts hardened steel.
Operating Temp. Range/Seals	-45°C to +93.3°C (“D”-Ring) (-50°F to +200°F) -31.7°C to +121.1°C (Fluorocarbon) (-25°F to +250°F)
Fluid Compatibility/Viscosity	Mineral-based or synthetic with lubricating properties at viscosities of 45 to 2000 SSU (6 to 420 cSt)
Filtration	ISO Code 16/13, SAE Class 4 or better
Approx. Weight	.45 kg (1.0 lbs.)
Cavity	C10-3
Form Tool	Rougher NFT10-3R Finisher NFT10-3F

Performance Curve

Flow vs. Inlet Pressure

(Pressure rise through cartridge only)

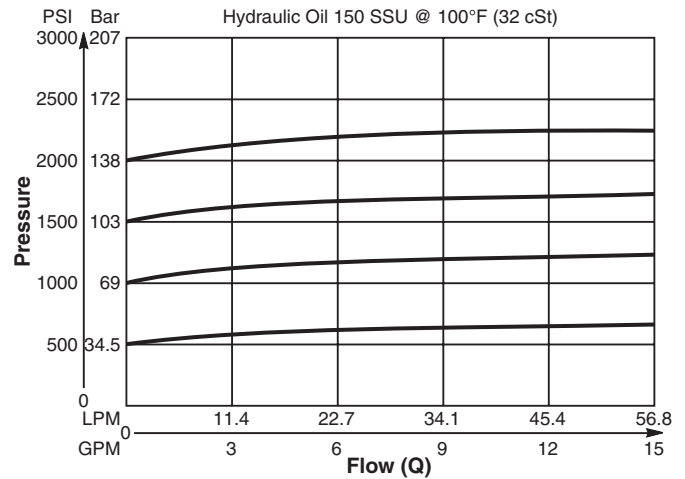

Dimensions Millimeters (Inches)

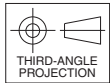
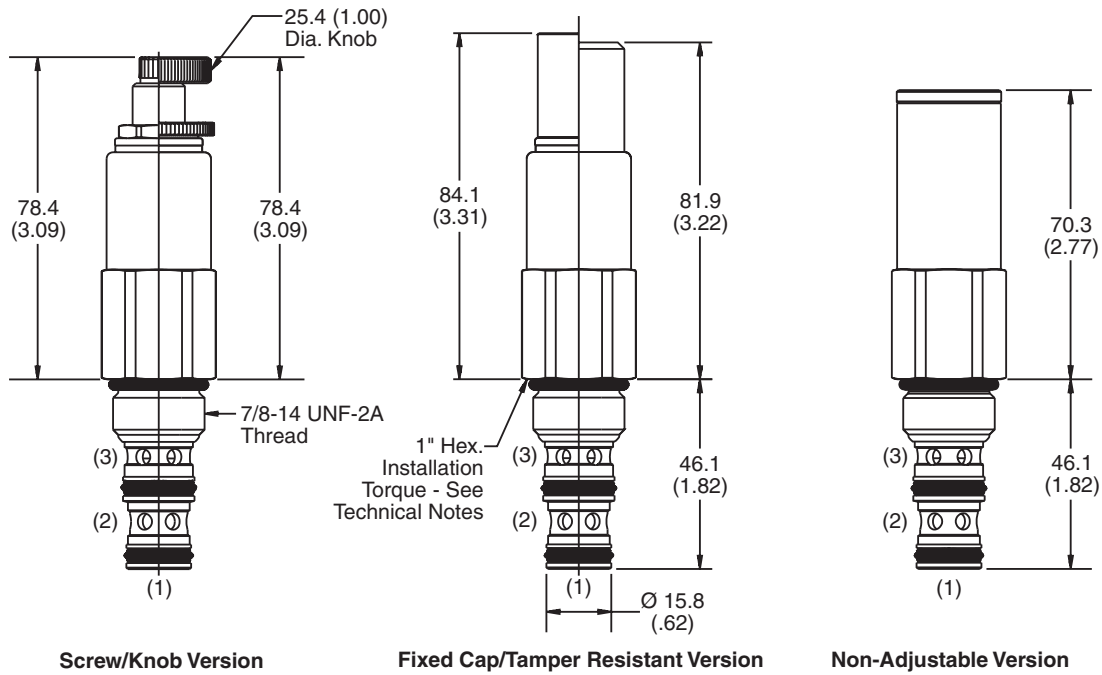

Screw/Knob Version

Fixed Cap/Tamper Resistant Version

Non-Adjustable Version

Ordering Information

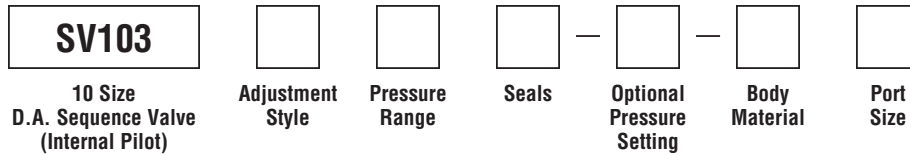

Code	Adjustment Style / Kit No.
F	Fixed style, covered adjustment
K	Knob Adjust (717784-10)
N	Non-Adjustable
S	Screw Adjust
T	Tamper Resistant Cap (717943)

Code	Seals / Kit No.
Omit	"D"-Ring / (SK10-3)
N	Nitrile / (SK10-3N)
V	Fluorocarbon / (SK10-3V)

Code	Body Material
Omit	Steel
A	Aluminum

Optional Pressure Setting	
Pressure ÷ 10	
i.e. 150 = 1500 PSI	
(Omit if standard setting is used)	
Setting Range:	
100 to 2000 PSI	
All settings at crack pressure,	
approximately .95 LPM (.25 GPM)	

Code	Port Size	Body Part No.
Omit	Cartridge Only	
4P	1/4" NPTF	(B10-3-*4P)
6P	3/8" NPTF	(B10-3-*6P)
8P	1/2" NPTF	(B10-3-*8P)
6T	SAE-6	(B10-3-*6T)
8T	SAE-8	(B10-3-*8T)
6B	3/8" BSPG	(B10-3-6B)†
8B	1/2" BSPG	(B10-3-*8B)

* Add "A" for aluminum, omit for steel..
 † Steel body only.

Code	Pressure Range
02	5.1 - 14 Bar (75 - 200 PSI) Standard Setting: 6.9 Bar (100 PSI) @ crack pressure, approximately .95 LPM (.25 GPM)
06	6.9 - 42 Bar (100 - 600 PSI) Standard Setting: 21 Bar (300 PSI) @ crack pressure, approximately .95 LPM (.25 GPM)
12	14 - 83 Bar (200 - 1200 PSI) Standard Setting: 42 Bar (600 PSI) @ crack pressure, approximately .95 LPM (.25 GPM)
20	28 - 138 Bar (400 - 2000 PSI) Standard Setting: 69 Bar (1000 PSI) @ crack pressure, approximately .95 LPM (.25 GPM)

Technical Information

- CV** Check Valves
- SH** Shuttle Valves
- LM** Load/Motor Controls
- FC** Flow Controls
- PC** Pressure Controls
- LE** Logic Elements
- DC** Directional Controls
- MV** Manual Valves
- SV** Solenoid Valves
- PV** Proportional Valves
- CE** Coils & Electronics
- BC** Bodies & Cavities
- TD** Technical Data

General Description

Direct Acting, Normally Closed Sequence Valve (Externally Piloted). With no pressure at the pilot port (port 1), both port 3 and port 2 are blocked. When the pilot pressure at port 1 exceeds the valve setting, the spool moves opening a path and allowing flow from port 3 to port 2. This valve internally drains the spring chamber to tank via the sequencing port, thus any backpressure on port 2 would be additive to the spring setting.

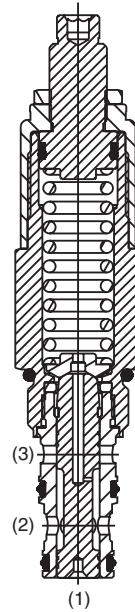
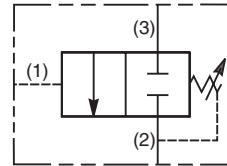

Features

- Hardened, precision ground parts for durability
- Internal mechanical stop limits spool travel eliminating spring solidification
- “D”-Ring eliminates backup rings
- All external parts have yellow zinc dichromate. This coating is ideal for salt spray applications.
- Fast response

Specifications

Rated Flow	38 LPM (10 GPM)
Maximum Inlet Pressure	250 Bar (3600 PSI)
Maximum Pressure Setting	138 Bar (2000 PSI)
Leakage at 150 SSU (32 cSt)	82 cc/min. (5 cu. in./min.) at 210 Bar (3000 PSI)
Cartridge Material	All parts steel. All operating parts hardened steel.
Operating Temp. Range/Seals	-45°C to +93.3°C (“D”-Ring) (-50°F to +200°F) -31.7°C to +121.1°C (Fluorocarbon) (-25°F to +250°F)
Fluid Compatibility/Viscosity	Mineral-based or synthetic with lubricating properties at viscosities of 45 to 2000 SSU (6 to 420 cSt)
Filtration	ISO Code 16/13, SAE Class 4 or better
Approx. Weight	.45 kg (1.0 lbs.)
Cavity	C10-3
Form Tool	Rougher NFT10-3R Finisher NFT10-3F

Performance Curve

Flow vs. Inlet Pressure

(Pressure rise through cartridge only)

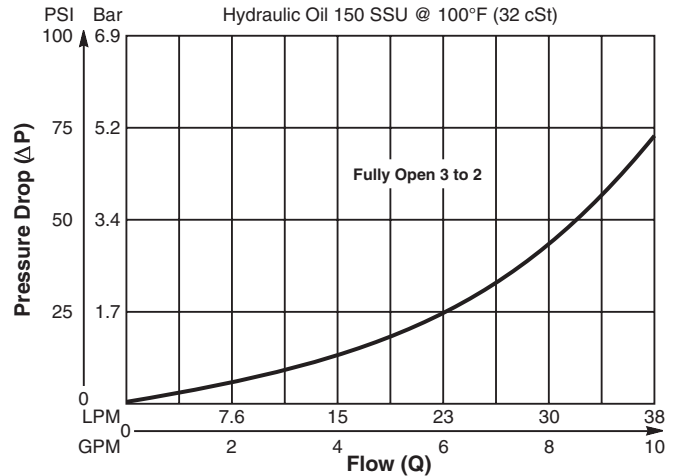

Dimensions Millimeters (Inches)

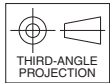
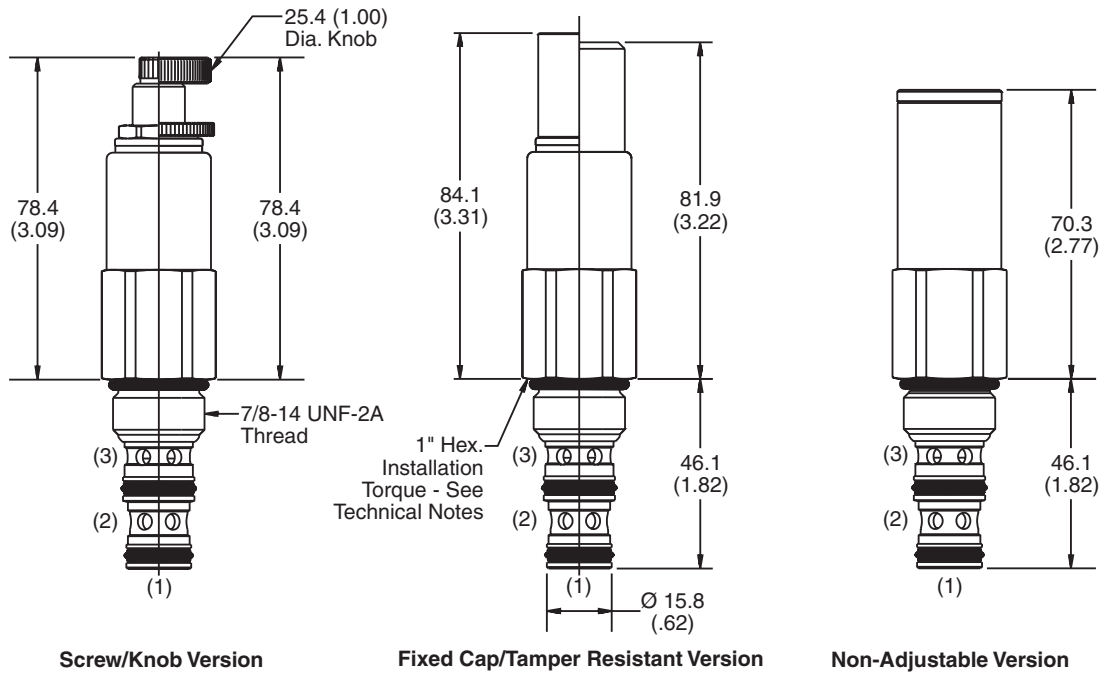

Ordering Information

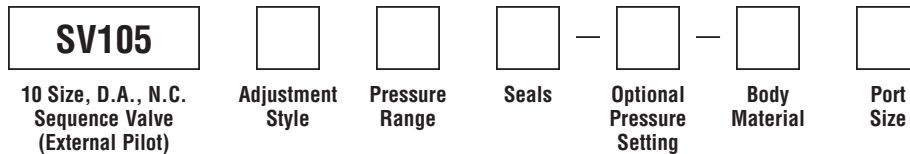

Code	Adjustment Style / Kit No.
F	Fixed style, covered adjustment
K	Knob Adjust (717784-10)
N	Non-Adjustable
S	Screw Adjust
T	Tamper Resistant Cap (717943)

Code	Seals / Kit No.
Omit	"D"-Ring / (SK10-3)
N	Nitrile / (SK10-3N)
V	Fluorocarbon / (SK10-3V)

Code	Body Material
Omit	Steel
A	Aluminum

Optional Pressure Setting	
Pressure ÷ 10	
i.e. 150 = 1500 PSI	
(Omit if standard setting is used)	
Setting Range:	
100 to 2000 PSI	
All settings at crack pressure,	
approximately .95 LPM (.25 GPM)	

Code	Port Size	Body Part No.
Omit	Cartridge Only	
6P	3/8" NPTF	(B10-3-*6P)
6T	SAE-6	(B10-3-*6T)
8T	SAE-8	(B10-3-*8T)
4B	1/4" BSPG	(B10-3-4B)†
6B	3/8" BSPG	(B10-3-6B)†

* Add "A" for aluminum, omit for steel..
 † Steel body only.

Code	Pressure Range
02	5.1 - 14 Bar (75 - 200 PSI) Standard Setting: 6.9 Bar (100 PSI) @ crack pressure, approximately .95 LPM (.25 GPM)
06	6.9 - 42 Bar (100 - 600 PSI) Standard Setting: 21 Bar (300 PSI) @ crack pressure, approximately .95 LPM (.25 GPM)
12	14 - 83 Bar (200 - 1200 PSI) Standard Setting: 42 Bar (600 PSI) @ crack pressure, approximately .95 LPM (.25 GPM)
20	28 - 138 Bar (400 - 2000 PSI) Standard Setting: 69 Bar (1000 PSI) @ crack pressure, approximately .95 LPM (.25 GPM)



- CV**
Check Valves
- SH**
Shuttle Valves
- LM**
Load/Motor Controls
- FC**
Flow Controls
- PC**
Pressure Controls
- LE**
Logic Elements
- DC**
Directional Controls
- MV**
Manual Valves
- SV**
Solenoid Valves
- PV**
Proportional Valves
- CE**
Coils & Electronics
- BC**
Bodies & Cavities
- TD**
Technical Data

Technical Information

- CV** Check Valves
- SH** Shuttle Valves
- LM** Load/Motor Controls
- FC** Flow Controls
- PC** Pressure Controls
- LE** Logic Elements
- DC** Directional Controls
- MV** Manual Valves
- SV** Solenoid Valves
- PV** Proportional Valves
- CE** Coils & Electronics
- BC** Bodies & Cavities
- TD** Technical Data

General Description

Direct Acting, Normally Closed Sequence Valve with External Pilot and Internal Drain. For additional information see Technical Tips on pages PC1-PC6.

Features

- Sealed pilot option available
- Hardened working parts for maximum durability
- All external parts zinc plated
- Adjustable and tamperproof versions available

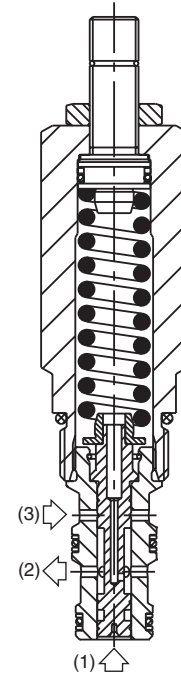
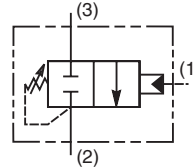
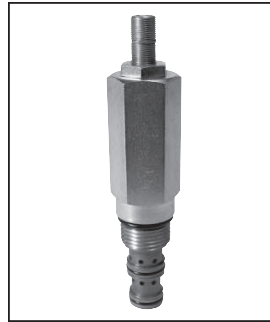

Specifications

Rated Flow	34 LPM (9 GPM)
Maximum Inlet Pressure	420 Bar (6000 PSI)
Maximum Pressure Setting	E - 2-80 Bar (30-1160 PSI) G - 2-166 Bar (30-2400 PSI)
Maximum Tank Pressure	420 Bar (6000 PSI)
Leakage at 150 SSU (32 cSt)	25 ml/min. @ 100 Bar (1450 PSI)
Cartridge Material	All parts steel. All operating parts hardened steel.
Operating Temp. Range/Seals	-40°C to +93.3°C (Nitrile) (-40°F to +200°F) -31.7°C to +121.1°C (Fluorocarbon) (-25°F to +250°F)
Fluid Compatibility/Viscosity	Mineral-based or synthetic with lubricating properties at viscosities of 45 to 2000 SSU (6 to 420 cSt)
Filtration	ISO Code 16/13, SAE Class 4 or better
Approx. Weight	0.30 kg (0.66 lbs.)
Cavity	C10-3 (See BC Section for more details)
Form Tool	Rougher NFT10-3R Finisher NFT10-3F

Performance Curves

(Pressure rise through cartridge only)

Flow vs. Inlet Pressure 3 to 2

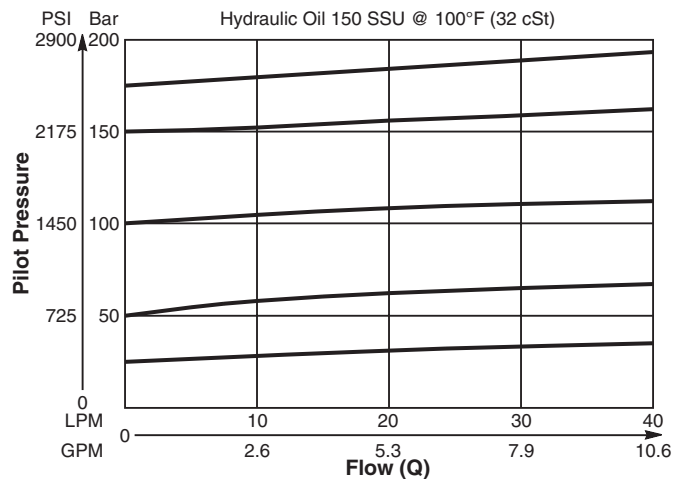

Pressure Drop vs. Flow 3 to 2

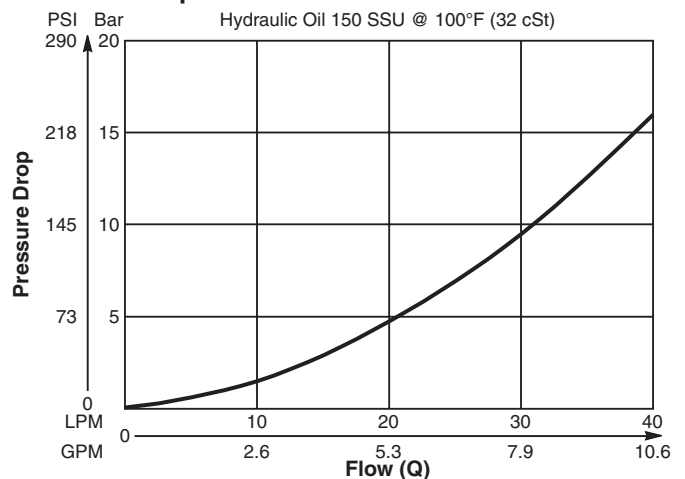

Dimensions Millimeters (Inches)

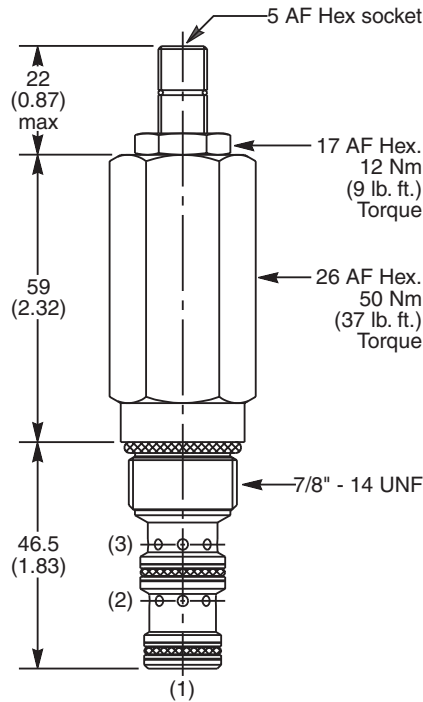

Ordering Information

B04F3	<input type="checkbox"/>	<input type="checkbox"/>	<input type="checkbox"/>	<input type="checkbox"/>	<input type="checkbox"/>	<input type="checkbox"/>	<input type="checkbox"/>
10 Size D.A. Sequence Valve (External Pilot & Internal Drain)	Pilot Pressure Adjustment Range	Adjustment Style	Pilot Switching Pressure	Seals	Sealed Pilot	Body Material	Port Size

Code	Pilot Pressure Adjustment Range
E	2 - 80 Bar (30 - 1160 PSI)
G	2 - 166 Bar (30 - 2400 PSI)
J	40 - 240 Bar (580 - 3500 PSI)

Code	Seals / Kit No.
N	Nitrile, Buna-N (Std.) / (SK30505N-1)
V	Fluorocarbon / (SK30505V-1)

Code	Body Material
Omit	Steel
A	Aluminum

Code	Adjustment Style / Kit No.
Z	Screw Adjust (Std.)
W	Knob Adjust
T	Tamper Resistant Cap (TC1130)

Code	Sealed Pilot
Omit	Omit if not required
S	Sealed Pilot

Code	Port Size	Body Part No.
Omit	Cartridge Only	
4P	1/4" NPTF	(B10-3-*4P)
6P	3/8" NPTF	(B10-3-*6P)
8P	1/2" NPTF	(B10-3-*8P)
6T	SAE-6	(B10-3-*6T)
8T	SAE-8	(B10-3-*8T)
6B	3/8" BSPG	(B10-3-6B)†
8B	1/2" BSPG	(B10-3-*8P)

* Add "A" for aluminum, omit for steel.
 † Steel body only.

Code	Pilot Switching Pressure
Omit	Omit for no setting (Std.)
	B04F3E Standard Setting: 40 Bar (580 PSI) @ 5 LPM (1.3 GPM)
	B04F3G Standard Setting: 80 Bar (1160 PSI) @ 5 LPM (1.3 GPM)
	B04F3J Standard Setting: 120 Bar (1750 PSI) @ 5 LPM (1.3 GPM)
	Specify setting if required

- CV** Check Valves
- SH** Shuttle Valves
- LM** Load/Motor Controls
- FC** Flow Controls
- PC** Pressure Controls
- LE** Logic Elements
- DC** Directional Controls
- MV** Manual Valves
- SV** Solenoid Valves
- PV** Proportional Valves
- CE** Coils & Electronics
- BC** Bodies & Cavities
- TD** Technical Data

Technical Information

- CV** Check Valves
- SH** Shuttle Valves
- LM** Load/Motor Controls
- FC** Flow Controls
- PC** Pressure Controls
- LE** Logic Elements
- DC** Directional Controls
- MV** Manual Valves
- SV** Solenoid Valves
- PV** Proportional Valves
- CE** Coils & Electronics
- BC** Bodies & Cavities
- TD** Technical Data

General Description

Direct Acting, Normally Open Sequence Valve with External Pilot and Internal Drain. For additional information see Technical Tips on pages PC1-PC6.

Features

- Sealed pilot option available
- Hardened working parts for maximum durability
- All external parts zinc plated
- Adjustable and tamperproof versions available

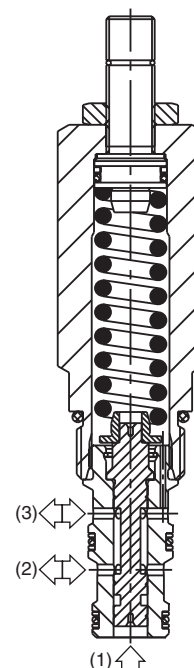
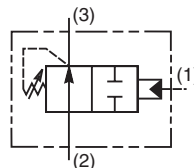
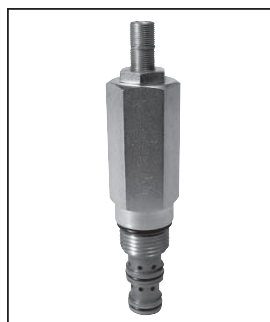

Specifications

Rated Flow	40 LPM (10.6 GPM)
Maximum Inlet Pressure	420 Bar (6000 PSI)
Maximum Pressure Setting	E - 2-80 Bar (30-1160 PSI) G - 2-166 Bar (30-2400 PSI)
Maximum Tank Pressure	420 Bar (6000 PSI)
Leakage at 150 SSU (32 cSt)	25 ml/min. @ 100 Bar (1450 PSI)
Cartridge Material	All parts steel. All operating parts hardened steel.
Operating Temp. Range/Seals	-40°C to +93.3°C (Nitrile) (-40°F to +200°F) -31.7°C to +121.1°C (Fluorocarbon) (-25°F to +250°F)
Fluid Compatibility/Viscosity	Mineral-based or synthetic with lubricating properties at viscosities of 45 to 2000 SSU (6 to 420 cSt)
Filtration	ISO Code 16/13, SAE Class 4 or better
Approx. Weight	0.30 kg (0.66 lbs.)
Cavity	C10-3 (See BC Section for more details)
Form Tool	Rougher NFT10-3R Finisher NFT10-3F

Performance Curves

(Pressure rise through cartridge only)

Flow vs. Inlet Pressure 2 to 3

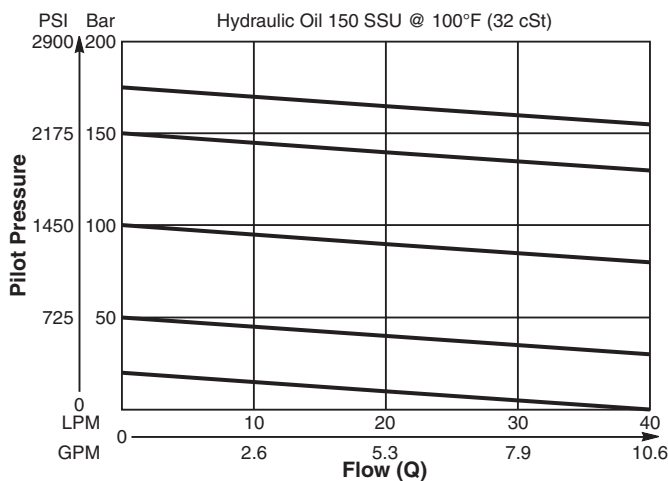

Pressure Drop vs. Flow 2 to 3

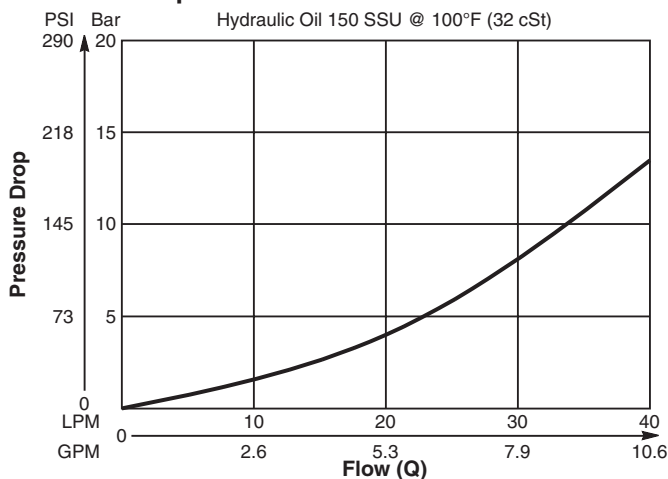

Dimensions Millimeters (Inches)

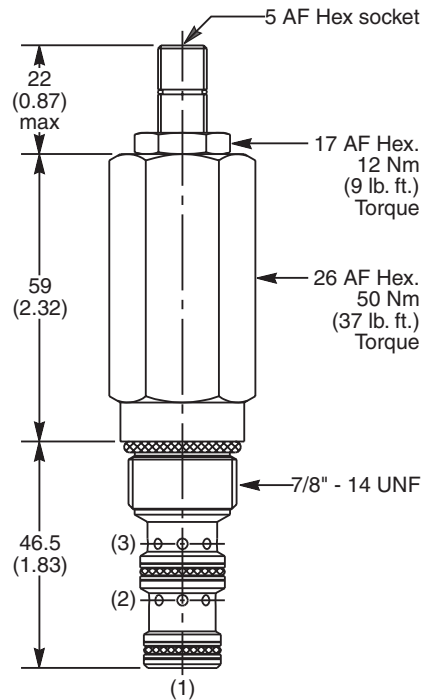

Ordering Information

B04G3							
10 Size D.A. Sequence Valve (External Pilot & Internal Drain)	Pilot Pressure Adjustment Range	Adjustment Style	Pilot Switching Pressure	Seals	Sealed Pilot	Body Material	Port Size

Code	Pilot Pressure Adjustment Range
E	2 - 80 Bar (30 - 1160 PSI)
G	2 - 166 Bar (30 - 2400 PSI)
J	40 - 240 Bar (580 - 3500 PSI)

Code	Seals / Kit No.
N	Nitrile, Buna-N (Std.) / (SK30505N-1)
V	Fluorocarbon / (SK30505V-1)

Code	Body Material
Omit	Steel
A	Aluminum

Code	Adjustment Style / Kit No.
Z	Screw Adjust (Std.)
W	Knob Adjust
T	Tamper Resistant Cap (TC1130)

Code	Sealed Pilot
Omit	Omit if not required
S	Sealed Pilot

Code	Port Size	Body Part No.
Omit	Cartridge Only	
4P	1/4" NPTF	(B10-3-*4P)
6P	3/8" NPTF	(B10-3-*6P)
8P	1/2" NPTF	(B10-3-*8P)
6T	SAE-6	(B10-3-*6T)
8T	SAE-8	(B10-3-*8T)
6B	3/8" BSPG	(B10-3-6B)†
8B	1/2" BSPG	(B10-3-*8P)

* Add "A" for aluminum, omit for steel.
 † Steel body only.

Code	Pilot Switching Pressure
Omit	Omit for no setting (Std.) B04G3E Standard Setting: 40 Bar (580 PSI) @ 5 LPM (1.3 GPM) B04G3G Standard Setting: 80 Bar (1160 PSI) @ 5 LPM (1.3 GPM) B04G3J Standard Setting: 120 Bar (1750 PSI) @ 5 LPM (1.3 GPM) Specify setting if required

- CV** Check Valves
- SH** Shuttle Valves
- LM** Load/Motor Controls
- FC** Flow Controls
- PC** Pressure Controls
- LE** Logic Elements
- DC** Directional Controls
- MV** Manual Valves
- SV** Solenoid Valves
- PV** Proportional Valves
- CE** Coils & Electronics
- BC** Bodies & Cavities
- TD** Technical Data

Technical Information

- CV** Check Valves
- SH** Shuttle Valves
- LM** Load/Motor Controls
- FC** Flow Controls
- PC** Pressure Controls
- LE** Logic Elements
- DC** Directional Controls
- MV** Manual Valves
- SV** Solenoid Valves
- PV** Proportional Valves
- CE** Coils & Electronics
- BC** Bodies & Cavities
- TD** Technical Data

General Description

Direct Acting, Normally Closed Sequence Valve with External Pilot and Drain. For additional information see Technical Tips on pages PC1-PC6.

Features

- Sealed pilot option available
- Hardened working parts for maximum durability
- All external parts zinc plated
- Adjustable and tamperproof versions available

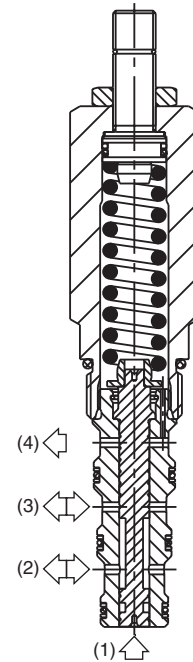
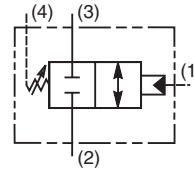
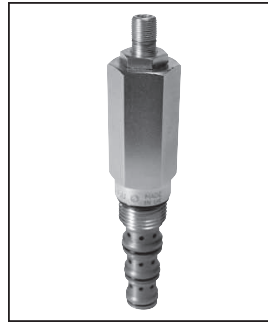

Specifications

Rated Flow	47 LPM (12 GPM)
Maximum Inlet Pressure	420 Bar (6000 PSI)
Maximum Pressure Setting	E - 2-80 Bar (30-1160 PSI) G - 2-166 Bar (30-2400 PSI)
Maximum Tank Pressure	420 Bar (6000 PSI)
Leakage at 150 SSU (32 cSt)	25 ml/min. @ 100 Bar (1450 PSI)
Cartridge Material	All parts steel. All operating parts hardened steel.
Operating Temp. Range/Seals	-40°C to +93.3°C (Nitrile) (-40°F to +200°F) -31.7°C to +121.1°C (Fluorocarbon) (-25°F to +250°F)
Fluid Compatibility/Viscosity	Mineral-based or synthetic with lubricating properties at viscosities of 45 to 2000 SSU (6 to 420 cSt)
Filtration	ISO Code 16/13, SAE Class 4 or better
Approx. Weight	0.33 kg (0.73 lbs.)
Cavity	C10-4 (See BC Section for more details)
Form Tool	Rougher NFT10-4R Finisher NFT10-4F

Performance Curves

(Pressure rise through cartridge only)

Flow vs. Inlet Pressure 2 to 3

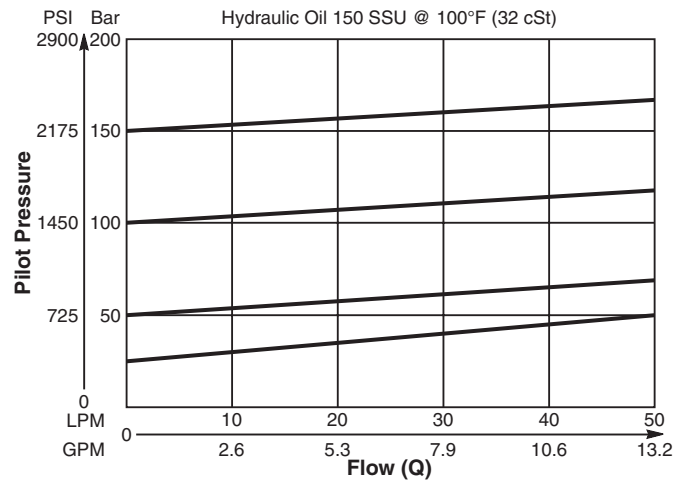

Pressure Drop vs. Flow 3 to 2

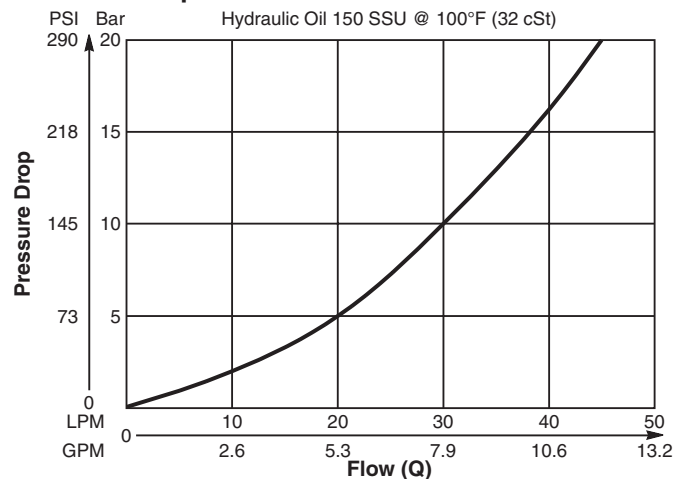

Dimensions Millimeters (Inches)

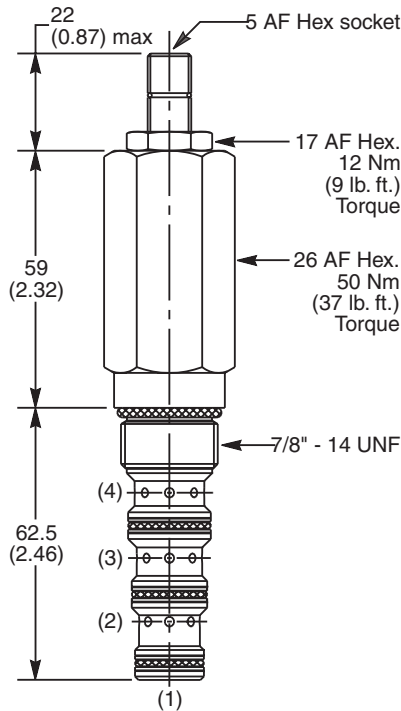

Ordering Information

B04H4	<input type="checkbox"/>	<input type="checkbox"/>	<input type="checkbox"/>	<input type="checkbox"/>	<input type="checkbox"/>	<input type="checkbox"/>	<input type="checkbox"/>
10 Size D.A. Sequence Valve (External Pilot and Drain)	Pilot Pressure Adjustment Range	Adjustment Style	Pilot Switching Pressure	Seals	Sealed Pilot	Body Material	Port Size

Code	Pilot Pressure Adjustment Range
E	2 - 80 Bar (30 - 1160 PSI)
G	2 - 166 Bar (30 - 2400 PSI)
J	40 - 240 Bar (580 - 3500 PSI)

Code	Seals / Kit No.
N	Nitrile, Buna-N (Std.) / (SK30506N-1)
V	Fluorocarbon / (SK30506V-1)

Code	Body Material
Omit	Steel
A	Aluminum

Code	Adjustment Style / Kit No.
Z	Screw Adjust (Std.)
W	Knob Adjust
T	Tamper Resistant Cap (TC1130)

Code	Sealed Pilot
Omit	Omit if not required
S	Sealed Pilot

Code	Port Size	Body Part No.
Omit	Cartridge Only	
6P	3/8" NTPF	(B10-4-*6P)
6T	SAE-6	(B10-4-*6T)
8T	SAE-8	(B10-4-*8T)
6B	3/8" BSPG	(B10-4-6B)†

* Add "A" for aluminum, omit for steel.
 † Steel bodies only

Code	Pilot Switching Pressure
Omit	Omit for Standard Setting
	B04H4E Standard Setting: 40 Bar (580 PSI) @ 5 LPM (1.3 GPM)
	B04H4G Standard Setting: 80 Bar (1160 PSI) @ 5 LPM (1.3 GPM)
	B04H4J Standard Setting: 120 Bar (1750 PSI) @ 5 LPM (1.3 GPM)
	Specify setting if required

- CV** Check Valves
- SH** Shuttle Valves
- LM** Load/Motor Controls
- FC** Flow Controls
- PC** Pressure Controls
- LE** Logic Elements
- DC** Directional Controls
- MV** Manual Valves
- SV** Solenoid Valves
- PV** Proportional Valves
- CE** Coils & Electronics
- BC** Bodies & Cavities
- TD** Technical Data

Technical Information

- CV** Check Valves
- SH** Shuttle Valves
- LM** Load/Motor Controls
- FC** Flow Controls
- PC** Pressure Controls
- LE** Logic Elements
- DC** Directional Controls
- MV** Manual Valves
- SV** Solenoid Valves
- PV** Proportional Valves
- CE** Coils & Electronics
- BC** Bodies & Cavities
- TD** Technical Data

General Description

Direct Acting, Normally Open Sequence Valve (Externally Piloted, Externally Drained). With no pressure at the pilot port (port 1), bi-directional flow is allowed between port 3 and port 2.



When the pilot pressure at port 1 exceeds the valve setting the spool moves blocking both port 3 and port 2. By externally draining the spring chamber to tank (port 4), the valve is insensitive to back pressure at the sequencing ports.

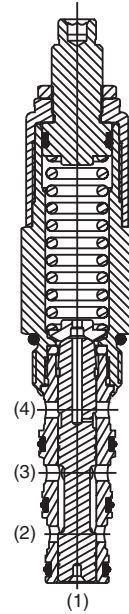
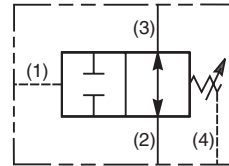

Features

- Hardened, precision ground parts for durability
- Internal mechanical stop limits spool travel eliminating spring solidification
- “D”-Ring eliminates backup rings
- All external parts have yellow zinc dichromate. This coating is ideal for salt spray applications.
- Fast response

Specifications

Rated Flow	30 LPM (8 GPM)
Maximum Inlet Pressure	250 Bar (3600 PSI)
Maximum Pressure Setting	138 Bar (2000 PSI)
Leakage at 150 SSU (32 cSt)	82 cc/min. (5 cu. in./min.) at 210 Bar (3000 PSI)
Cartridge Material	All parts steel. All operating parts hardened steel.
Operating Temp. Range/Seals	-45°C to +93.3°C (“D”-Ring) (-50°F to +200°F) -31.7°C to +121.1°C (Fluorocarbon) (-25°F to +250°F)
Fluid Compatibility/Viscosity	Mineral-based or synthetic with lubricating properties at viscosities of 45 to 2000 SSU (6 to 420 cSt)
Filtration	ISO Code 16/13, SAE Class 4 or better
Approx. Weight	.45 kg (1.0 lbs.)
Cavity	C10-4
Form Tool	Rougher NFT10-4R Finisher NFT10-4F

Performance Curve

Flow vs. Inlet Pressure

(Pressure rise through cartridge only)

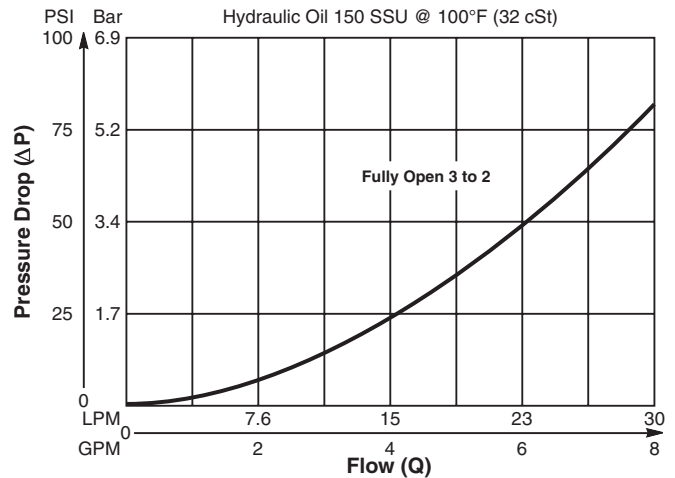

Dimensions Millimeters (Inches)

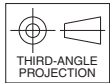
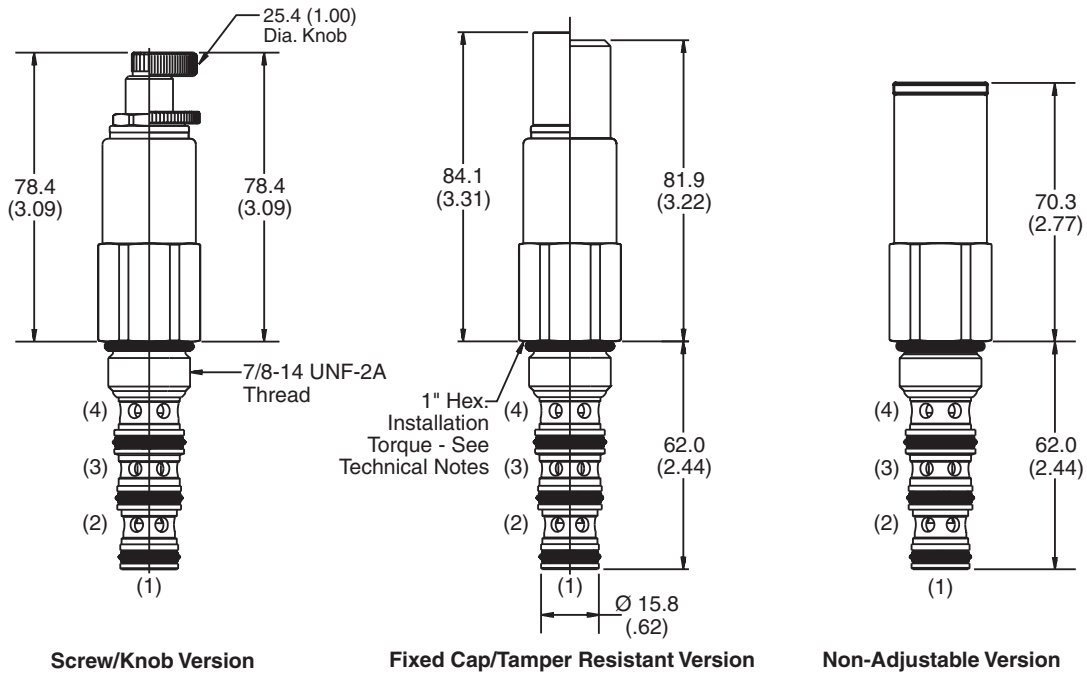

Ordering Information

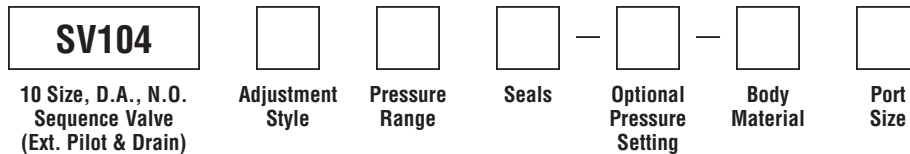

Code	Adjustment Style / Kit No.
F	Fixed style, covered adjustment
K	Knob Adjust (717784-10)
N	Non-Adjustable
S	Screw Adjust
T	Tamper Resistant Cap (717943)

Code	Seals / Kit No.
Omit	"D"-Ring / (SK10-4)
N	Nitrile / (SK10-4N)
V	Fluorocarbon / (SK10-4V)

Code	Body Material
Omit	Steel
A	Aluminum

Code	Pressure Range
02	5.1 - 14 Bar (75 - 200 PSI) Standard Setting: 6.9 Bar (100 PSI) @ crack pressure, approximately .95 LPM (.25 GPM)
06	6.9 - 42 Bar (100 - 600 PSI) Standard Setting: 21 Bar (300 PSI) @ crack pressure, approximately .95 LPM (.25 GPM)
12	14 - 83 Bar (200 - 1200 PSI) Standard Setting: 42 Bar (600 PSI) @ crack pressure, approximately .95 LPM (.25 GPM)
20	28 - 138 Bar (400 - 2000 PSI) Standard Setting: 69 Bar (1000 PSI) @ crack pressure, approximately .95 LPM (.25 GPM)

Optional Pressure Setting
Pressure ÷ 10 i.e. 150 = 1500 PSI (Omit if standard setting is used) Setting Range: 100 to 2000 PSI All settings at crack pressure, approximately .95 LPM (.25 GPM)

Code	Port Size	Body Part No.
Omit	Cartridge Only	
6P	3/8" NPTF	(B10-4-*6P)
6T	SAE-6	(B10-4-*6T)
8T	SAE-8	(B10-4-*8T)
6B	3/8" BSPG	(B10-4-6B)†

* Add "A" for aluminum, omit for steel.
 † Steel body only.

Technical Information

- CV** Check Valves
- SH** Shuttle Valves
- LM** Load/Motor Controls
- FC** Flow Controls
- PC** Pressure Controls
- LE** Logic Elements
- DC** Directional Controls
- MV** Manual Valves
- SV** Solenoid Valves
- PV** Proportional Valves
- CE** Coils & Electronics
- BC** Bodies & Cavities
- TD** Technical Data

General Description

Direct Acting, Normally Open Sequence Valve with External Pilot and Drain. For additional information see Technical Tips on pages PC1-PC6.

Features

- Sealed pilot option available
- Hardened working parts for maximum durability
- All external parts zinc plated
- Adjustable and tamperproof versions available

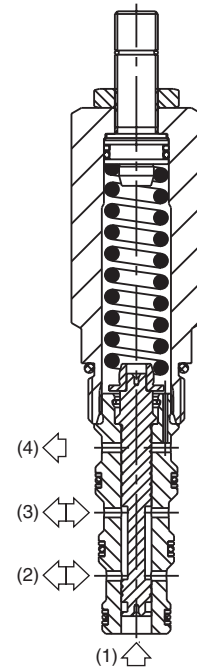
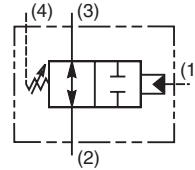
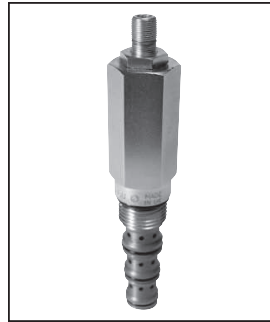

Specifications

Rated Flow	47 LPM (12 GPM)
Maximum Inlet Pressure	420 Bar (6000 PSI)
Maximum Pressure Setting	E - 2-80 Bar (30-1160 PSI) G - 2-166 Bar (30-2400 PSI)
Maximum Tank Pressure	420 Bar (6000 PSI)
Leakage at 150 SSU (32 cSt)	25 ml/min. @ 100 Bar (1450 PSI)
Cartridge Material	All parts steel. All operating parts hardened steel.
Operating Temp. Range/Seals	-40°C to +93.3°C (Nitrile) (-40°F to +200°F) -31.7°C to +121.1°C (Fluorocarbon) (-25°F to +250°F)
Fluid Compatibility/Viscosity	Mineral-based or synthetic with lubricating properties at viscosities of 45 to 2000 SSU (6 to 420 cSt)
Filtration	ISO Code 16/13, SAE Class 4 or better
Approx. Weight	0.33 kg (0.73 lbs.)
Cavity	C10-4 (See BC Section for more details)
Form Tool	Rougher NFT10-4R Finisher NFT10-4F

Performance Curves

(Pressure rise through cartridge only)

Flow vs. Inlet Pressure 2 to 3 & 3 to 2

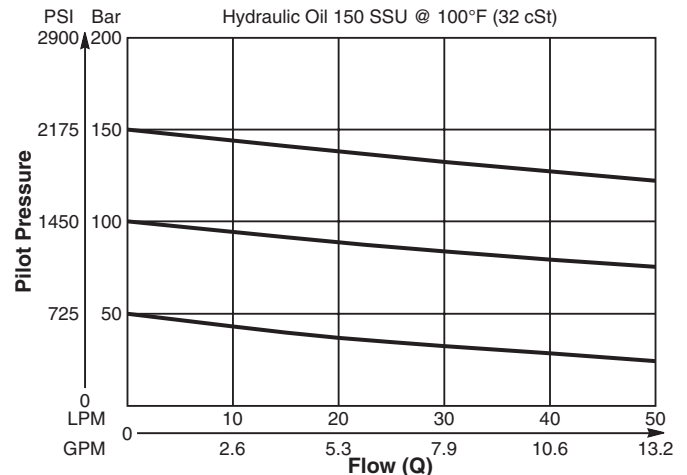

Pressure Drop vs. Flow 2 to 3 & 3 to 2

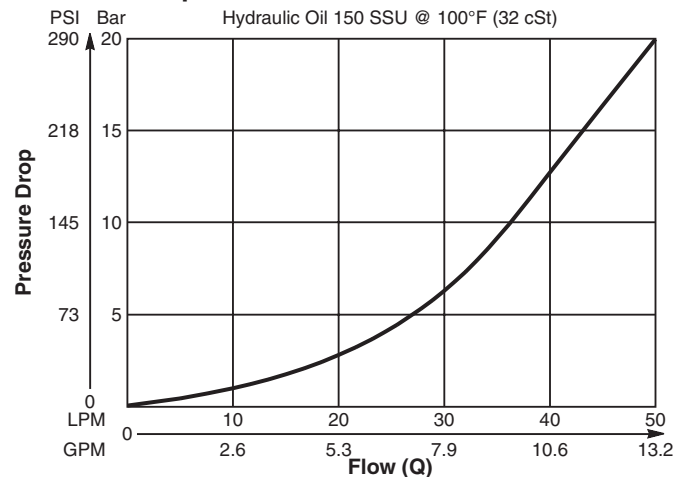

Dimensions Millimeters (Inches)

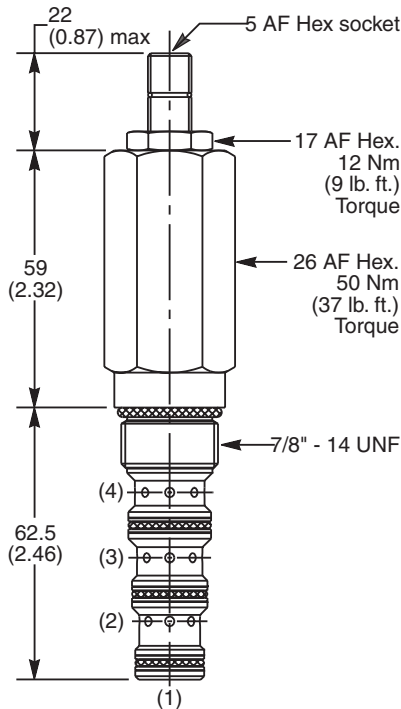

Ordering Information

B04J4							
10 Size D.A. Sequence Valve (External Pilot and Drain)	Pilot Pressure Adjustment Range	Adjustment Style	Pilot Switching Pressure	Seals	Sealed Pilot	Body Material	Port Size

Code	Pilot Pressure Adjustment Range
E	2 - 80 Bar (30 - 1160 PSI)
G	2 - 166 Bar (30 - 2400 PSI)
J	40 - 240 Bar (580 - 3500 PSI)

Code	Seals / Kit No.
N	Nitrile, Buna-N (Std.) / (SK30506N-1)
V	Fluorocarbon / (SK30506V-1)

Code	Body Material
Omit	Steel
A	Aluminum

Code	Adjustment Style / Kit No.
Z	Screw Adjust (Std.)
W	Knob Adjust
T	Tamper Resistant Cap (TC1130)

Code	Sealed Pilot
Omit	Omit if not required
S	Sealed Pilot

Code	Port Size	Body Part No.
Omit	Cartridge Only	
6P	3/8" NTPF	(B10-4-*6P)
6T	SAE-6	(B10-4-*6T)
8T	SAE-8	(B10-4-*8T)
6B	3/8" BSPG	(B10-4-6B)†

* Add "A" for aluminum, omit for steel.
 † Steel bodies only

Code	Pilot Switching Pressure
Omit	Omit for no setting (Std.)
	B04J4E Standard Setting: 40 Bar (580 PSI) @ 5 LPM (1.3 GPM)
	B04J4G Standard Setting: 80 Bar (1160 PSI) @ 5 LPM (1.3 GPM)
	B04J4J Standard Setting: 120 Bar (1750 PSI) @ 5 LPM (1.3 GPM)
	Specify setting if required

- CV** Check Valves
- SH** Shuttle Valves
- LM** Load/Motor Controls
- FC** Flow Controls
- PC** Pressure Controls
- LE** Logic Elements
- DC** Directional Controls
- MV** Manual Valves
- SV** Solenoid Valves
- PV** Proportional Valves
- CE** Coils & Electronics
- BC** Bodies & Cavities
- TD** Technical Data

Technical Information

- CV** Check Valves
- SH** Shuttle Valves
- LM** Load/Motor Controls
- FC** Flow Controls
- PC** Pressure Controls
- LE** Logic Elements
- DC** Directional Controls
- MV** Manual Valves
- SV** Solenoid Valves
- PV** Proportional Valves
- CE** Coils & Electronics
- BC** Bodies & Cavities
- TD** Technical Data

General Description

Direct Acting, Normally Open, 3 Way Sequence Valve with Internal Pilot and External Drain. For additional information see Technical Tips on pages PC1-PC6.

Features

- Sealed pilot option available
- Hardened working parts for maximum durability
- All external parts zinc plated
- Adjustable and tamperproof versions available

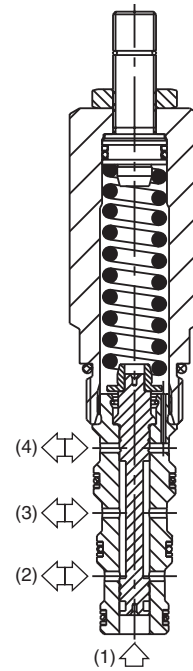
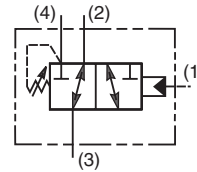
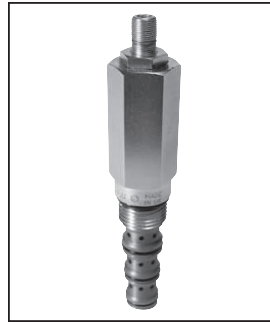

Specifications

Rated Flow	42 LPM (11 GPM)
Maximum Inlet Pressure	420 Bar (6000 PSI)
Maximum Pressure Setting	E - 2-80 Bar (30-1160 PSI) G - 2-166 Bar (30-2400 PSI)
Maximum Tank Pressure	420 Bar (6000 PSI)
Leakage at 150 SSU (32 cSt)	40 ml/min. @ 100 Bar (1450 PSI)
Cartridge Material	All parts steel. All operating parts hardened steel.
Operating Temp. Range/Seals	-40°C to +93.3°C (Nitrile) (-40°F to +200°F) -31.7°C to +121.1°C (Fluorocarbon) (-25°F to +250°F)
Fluid Compatibility/Viscosity	Mineral-based or synthetic with lubricating properties at viscosities of 45 to 2000 SSU (6 to 420 cSt)
Filtration	ISO Code 16/13, SAE Class 4 or better
Approx. Weight	0.33 kg (0.73 lbs.)
Cavity	C10-4 (See BC Section for more details)
Form Tool	Rougher NFT10-4R Finisher NFT10-4F

Performance Curves

(Pressure rise through cartridge only)

Flow vs. Inlet Pressure

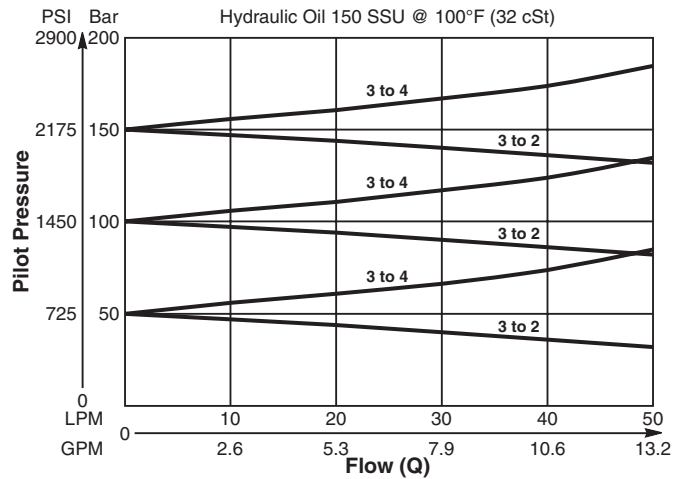

Pressure Drop vs. Flow

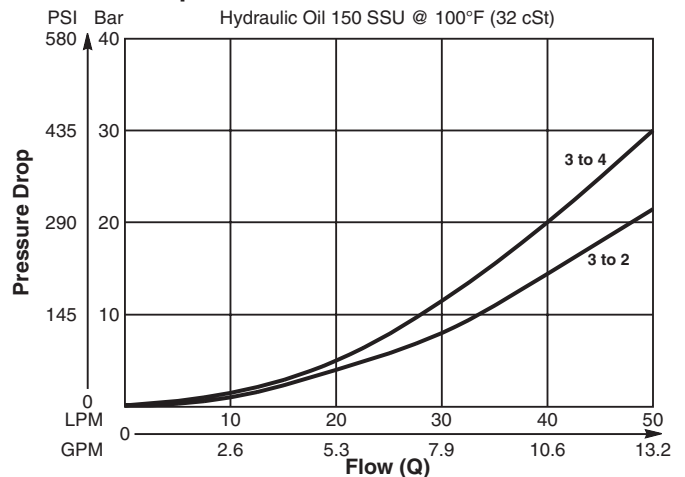

Dimensions Millimeters (Inches)

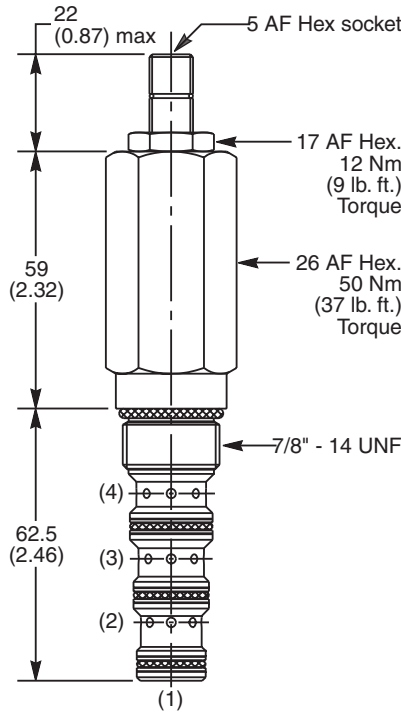

Ordering Information

B04K4							
10 Size D.A. Sequence Valve (Internal Pilot & External Drain)	Pilot Pressure Adjustment Range	Adjustment Style	Pilot Switching Pressure	Seals	Sealed Pilot	Body Material	Port Size

Code	Pilot Pressure Adjustment Range
E	2 - 80 Bar (30 - 1160 PSI)
G	2 - 166 Bar (30 - 2400 PSI)
J	40 - 240 Bar (580 - 3500 PSI)

Code	Seals / Kit No.
N	Nitrile, Buna-N (Std.) / (SK30506N-1)
V	Fluorocarbon / (SK30506V-1)

Code	Body Material
Omit	Steel
A	Aluminum

Code	Adjustment Style / Kit No.
Z	Screw Adjust (Std.)
W	Knob Adjust
T	Tamper Resistant Cap (TC1130)

Code	Sealed Pilot
Omit	Omit if not required
S	Sealed Pilot

Code	Port Size	Body Part No.
Omit	Cartridge Only	
6P	3/8" NTPF	(B10-4-*6P)
6T	SAE-6	(B10-4-*6T)
8T	SAE-8	(B10-4-*8T)
6B	3/8" BSPG	(B10-4-6B)†

* Add "A" for aluminum, omit for steel.
 † Steel bodies only

Code	Pilot Switching Pressure
Omit	Omit for Standard Setting
	B04K4E Standard Setting: 40 Bar (580 PSI) @ 5 LPM (1.3 GPM)
	B04K4G Standard Setting: 80 Bar (1160 PSI) @ 5 LPM (1.3 GPM)
	B04K4J Standard Setting: 120 Bar (1750 PSI) @ 5 LPM (1.3 GPM)
	Specify setting if required

- CV** Check Valves
- SH** Shuttle Valves
- LM** Load/Motor Controls
- FC** Flow Controls
- PC** Pressure Controls
- LE** Logic Elements
- DC** Directional Controls
- MV** Manual Valves
- SV** Solenoid Valves
- PV** Proportional Valves
- CE** Coils & Electronics
- BC** Bodies & Cavities
- TD** Technical Data

Technical Information

- CV** Check Valves
- SH** Shuttle Valves
- LM** Load/Motor Controls
- FC** Flow Controls
- PC** Pressure Controls
- LE** Logic Elements
- DC** Directional Controls
- MV** Manual Valves
- SV** Solenoid Valves
- PV** Proportional Valves
- CE** Coils & Electronics
- BC** Bodies & Cavities
- TD** Technical Data

General Description

Direct Acting Pressure Reducing/Relieving Valve. For additional information see Technical Tips on pages PC1-PC6.

Features

- Maximum pressure setting up to 150 Bar, 2175 PSI
- Three pressure ranges available for more accurate pressure control
- Partial reverse flow capability
- Hardened working parts for maximum durability
- Adjustable and tamperproof versions available
- All external parts zinc plated

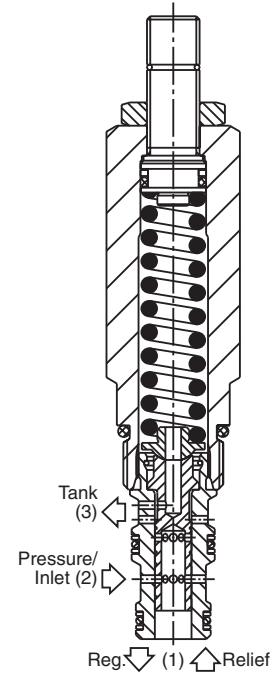
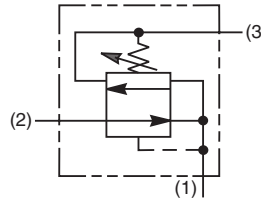
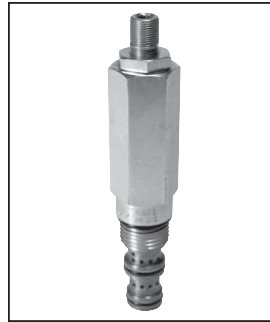

Specifications

Rated Flow	20 LPM (5 GPM)
Maximum Inlet Pressure	420 Bar (6000 PSI)
Maximum Pressure Setting	C - 5-40 Bar (73-580 PSI) E - 25-75 Bar (363-1088 PSI) G - 50-150 Bar (725-2175 PSI)
Maximum Tank Pressure	420 Bar (6000 PSI)
Cartridge Material	All parts steel. All operating parts hardened steel.
Operating Temp. Range/Seals	-40°C to +93.3°C (Nitrile) (-40°F to +200°F) -31.7°C to +121.1°C (Fluorocarbon) (-25°F to +250°F)
Fluid Compatibility/ Viscosity	Mineral-based or synthetic with lubricating properties at viscosities of 45 to 2000 SSU (6 to 420 cSt)
Filtration	ISO Code 16/13, SAE Class 4 or better
Approx. Weight	0.20 kg (0.44 lbs.)
Cavity	C08-3 (See BC Section for more details)
Form Tool	Rougher NFT08-3R Finisher NFT08-3F

Performance Curve

(Pressure rise through cartridge only)

Flow vs. Regulated Pressure

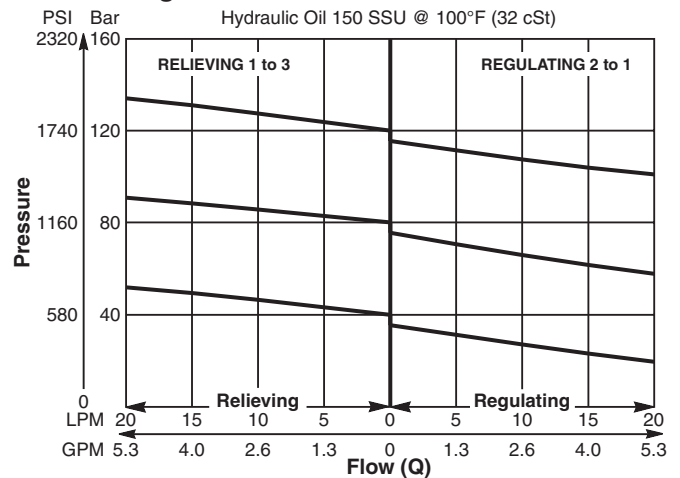

Dimensions Millimeters (Inches)

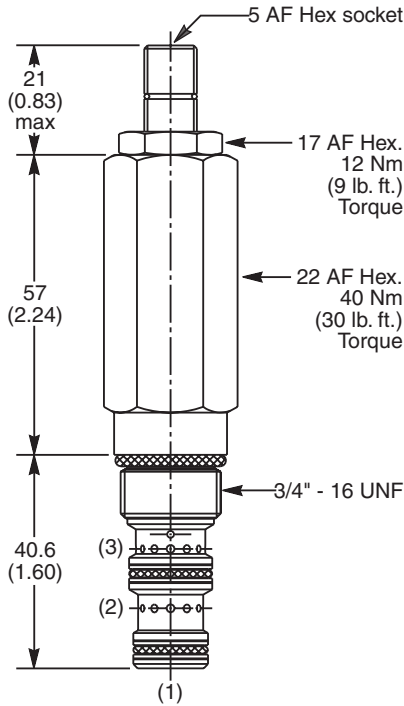

Ordering Information

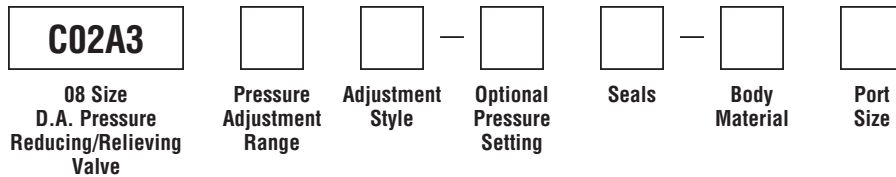

Code	Pressure Adjustment Range
C	5 - 40 Bar (73 - 580 PSI)
E	25 - 75 Bar (363 - 1088 PSI)
G	50 - 150 Bar (725 - 2175 PSI)

Code	Seals / Kit No.
N	Nitrile, Buna-N (Std.) / (SK30501N-1)
V	Fluorocarbon / (SK30501V-1)

Code	Body Material
Omit	Steel
A	Aluminum

Code	Adjustment Style / Kit No.
Z	Screw Adjust (Std.)
W	Knob Adjust
T	Tamper Resistant Cap (TC1130)

Code	Port Size	Body Part No.
Omit	Cartridge Only	
4P	1/4" NPTF	(B08-3-*4P)
4T	SAE-4	(B08-3-*4T)
6T	SAE-6	(B08-3-*6T)
6B	3/8" BSPG	(B08-3-*6B)

* Add "A" for aluminum, omit for steel.

Optional Pressure Setting	
Specify setting if required (Bar)	
C02A3C	Standard Setting: 20 Bar (290 PSI)
C02A3E	Standard Setting: 38 Bar (551 PSI)
C02A3G	Standard Setting: 75 Bar (1088 PSI)

- CV**
Check Valves
- SH**
Shuttle Valves
- LM**
Load/Motor Controls
- FC**
Flow Controls
- PC**
Pressure Controls
- LE**
Logic Elements
- DC**
Directional Controls
- MV**
Manual Valves
- SV**
Solenoid Valves
- PV**
Proportional Valves
- CE**
Coils & Electronics
- BC**
Bodies & Cavities
- TD**
Technical Data

Technical Information

- CV** Check Valves
- SH** Shuttle Valves
- LM** Load/Motor Controls
- FC** Flow Controls
- PC** Pressure Controls
- LE** Logic Elements
- DC** Directional Controls
- MV** Manual Valves
- SV** Solenoid Valves
- PV** Proportional Valves
- CE** Coils & Electronics
- BC** Bodies & Cavities
- TD** Technical Data

General Description

Direct Acting Pressure Reducing/Relieving Valve. For additional information see Technical Tips on pages PC1-PC6.



Note: The differential between system pressure and pressure setting of the valve can greatly affect the stability of this valve. For best performance, the inlet pressure setting should not exceed 69 Bar (1000 PSI) above the reducing valve setting.

Features

- Hardened, precision ground parts for durability
- Internal mechanical stop limits spool travel eliminating spring solidification
- “D”-Ring eliminates backup rings
- All external parts have yellow zinc dichromate. This coating is ideal for salt spray applications.

Specifications

Rated Flow	56 LPM (15 GPM)
Maximum Inlet Pressure	210 Bar (3000 PSI) 69 Bar (1000 PSI) maximum differential above valve setting for best stability
Maximum Pressure Setting	124 Bar (1800 PSI)
Maximum Tank Pressure	124 Bar (1800 PSI)
Maximum Drain Flow	120 mL/min. (0.03 GPM)
Cartridge Material	All parts steel. All operating parts hardened steel.
Operating Temp. Range/Seals	-45°C to +93.3°C (“D”-Ring) (-50°F to +200°F) -31.7°C to +121.1°C (Fluorocarbon) (-25°F to +250°F)
Fluid Compatibility/Viscosity	Mineral-based or synthetic with lubricating properties at viscosities of 45 to 2000 SSU (6 to 420 cSt)
Filtration	ISO Code 16/13, SAE Class 4 or better
Approx. Weight	.23 kg (0.5 lbs.)
Cavity	C10-3 (See BC Section for more details)
Form Tool	Rougher NTF10-3R Finisher NFT10-3F

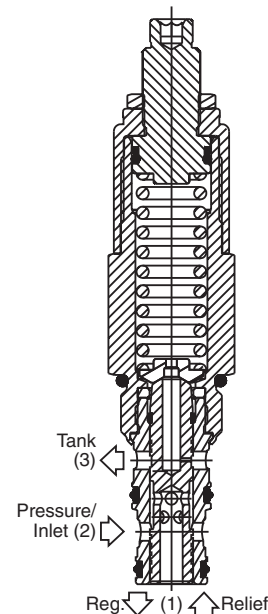
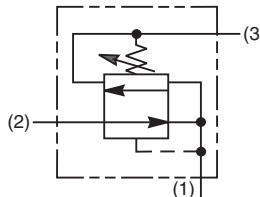

Performance Curves

(Pressure rise through cartridge only)

Flow vs. Regulated Pressure

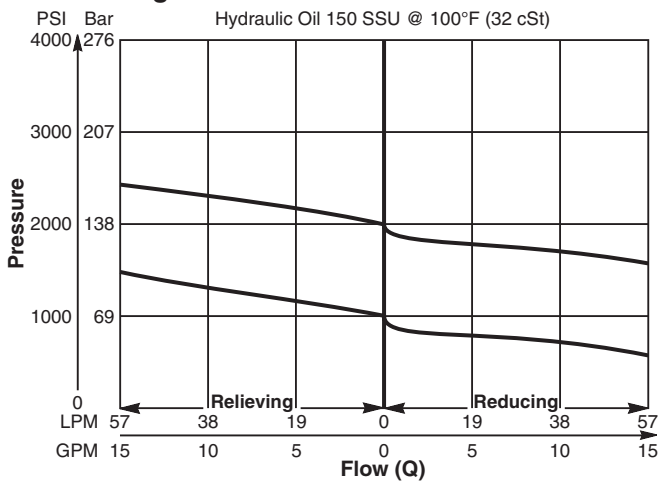

Pressure vs. Flow

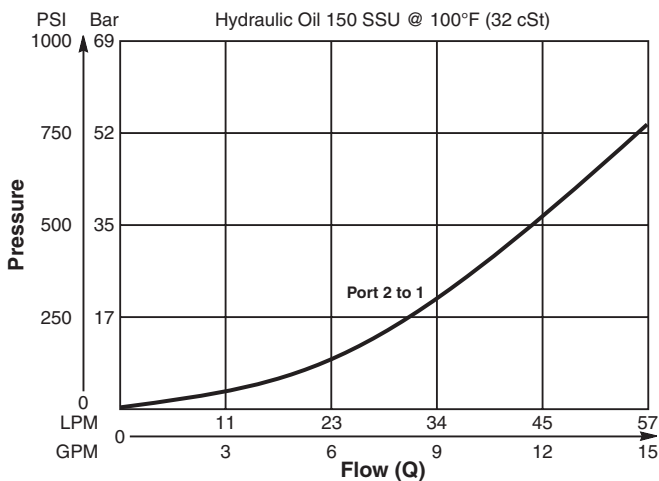

Dimensions Millimeters (Inches)

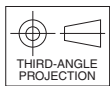
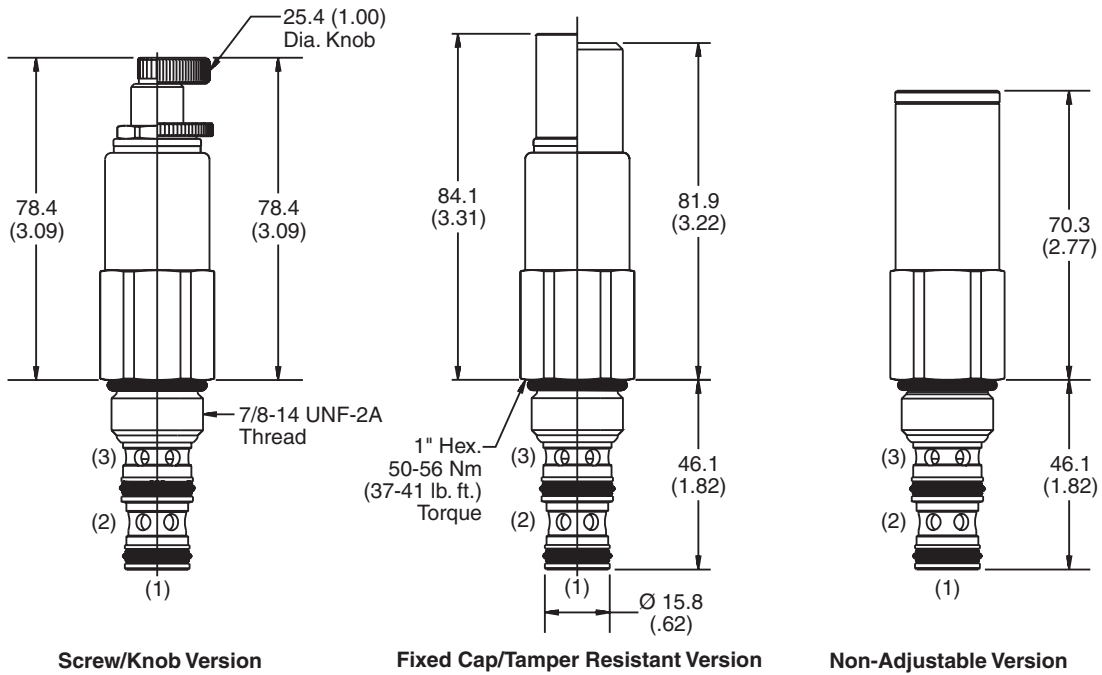

Screw/Knob Version

Fixed Cap/Tamper Resistant Version

Non-Adjustable Version

Ordering Information

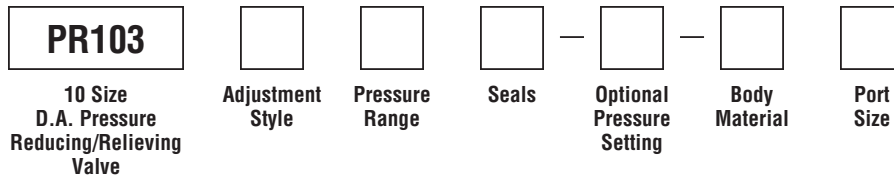

Code	Adjustment Style / Kit No.
F	Fixed style, preset at factory.
K	Knob Adjust (717784-10)
N	Non-Adjustable
S	Screw Adjust
T	Tamper Resistant Cap (717943)

Code	Seals / Kit No.
Omit	"D"-Ring / (SK10-3)
N	Nitrile / (SK10-3N)
V	Fluorocarbon / (SK10-3V)

Code	Body Material
Omit	Steel
A	Aluminum

Code	Pressure Range
02	5.2 - 13.8 Bar (75 - 200 PSI) Standard Setting: 6.9 Bar (100 PSI) @ .95 LPM (.25 GPM)
06	17.2 - 41.4 Bar (250 - 600 PSI) Standard Setting: 20.7 Bar (300 PSI) @ .95 LPM (.25 GPM)
12	39.3 - 83 Bar (570 - 1200 PSI) Standard Setting: 41.4 Bar (600 PSI) @ .95 LPM (.25 GPM)
21	41.4 - 124.1 Bar (600 - 1800 PSI) Standard Setting: 69 Bar (1000 PSI) @ .95 LPM (.25 GPM)

Optional Pressure Setting
Pressure ÷ 10 i.e. 150 = 1500 PSI (Omit if standard setting is used) Setting Range: 50 to 2100 PSI All settings at .95 LPM (.25 GPM)

Code	Port Size	Body Part No.
Omit	Cartridge Only	
4P	1/4" NPTF	(B10-3-*4P)
6P	3/8" NPTF	(B10-3-*6P)
8P	1/2" NPTF	(B10-3-*8P)
6T	SAE-6	(B10-3-*6T)
8T	SAE-8	(B10-3-*8T)
6B	3/8" BSPG	(B10-3-6B)†
8B	1/2" BSPG	(B10-3-*8B)

* Add "A" for aluminum, omit for steel.
 † Steel body only.

Technical Information

- CV** Check Valves
- SH** Shuttle Valves
- LM** Load/Motor Controls
- FC** Flow Controls
- PC** Pressure Controls
- LE** Logic Elements
- DC** Directional Controls
- MV** Manual Valves
- SV** Solenoid Valves
- PV** Proportional Valves
- CE** Coils & Electronics
- BC** Bodies & Cavities
- TD** Technical Data

General Description

Pilot Operated Pressure Reducing Valve. For additional information see Technical Tips on pages PC1-PC6.



Features

- Hardened, precision ground parts for durability
- Low profile adapter for minimal space requirements
- Fully guided pilot for more consistent reseal
- Steel adapters are coated with yellow zinc dichromate for protection from salt spray
- Polyurethane "D"-Ring eliminates backup rings and prevents hydrolysis
- Internal screening protects pilot spring from debris

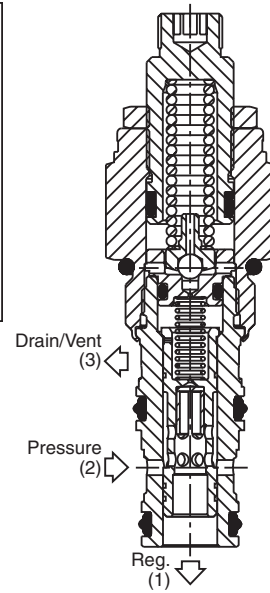
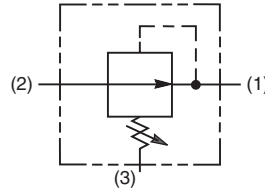
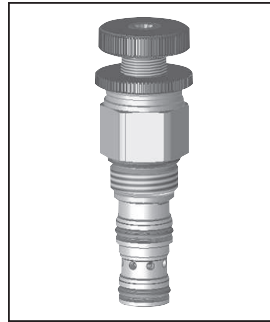

Specifications

Rated Flow	30 LPM (8 GPM)
Maximum Inlet Pressure	380 Bar (5500 PSI)
Maximum Pressure Setting	350 Bar (5000 PSI)
Maximum Tank Pressure	350 Bar (5000 PSI)
Maximum Drain Flow	0.56 LPM (0.15 GPM)
Cartridge Material	All parts steel. All operating parts hardened steel.
Operating Temp. Range/Seals	-45°C to +93.3°C ("D"-Ring) (-50°F to +200°F) -31.7°C to +121.1°C (Fluorocarbon) (-25°F to +250°F)
Fluid Compatibility/Viscosity	Mineral-based or synthetic with lubricating properties at viscosities of 45 to 2000 SSU (6 to 420 cSt)
Filtration	ISO Code 16/13, SAE Class 4 or better
Approx. Weight	.11 kg (.25 lbs.)
Cavity	C08-3 (See BC Section for more details)
Form Tool	Rougher NTF08-3R Finisher NFT08-3F

Performance Curves

Flow vs. Pressure (Through cartridge only)

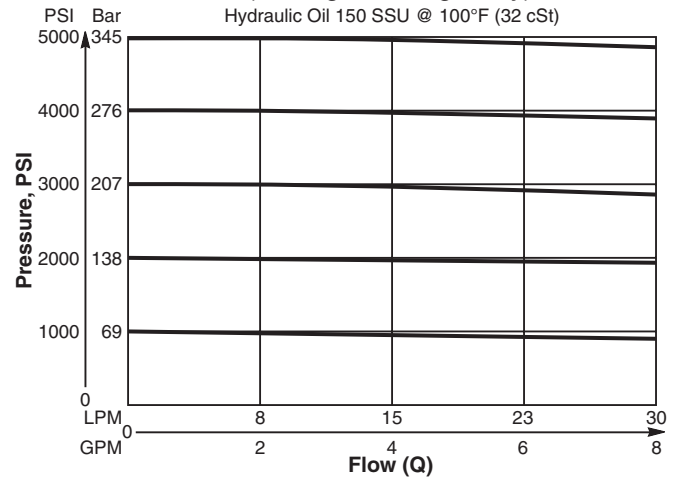

Flow vs. Pressure Drop (Through cartridge only)

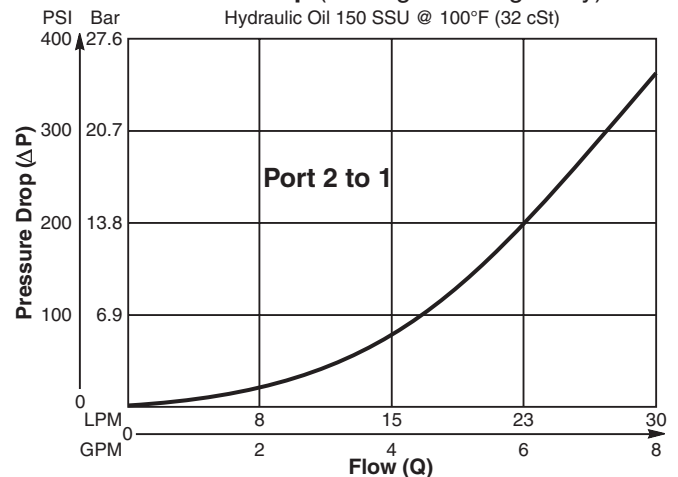

Dimensions Millimeters (Inches)

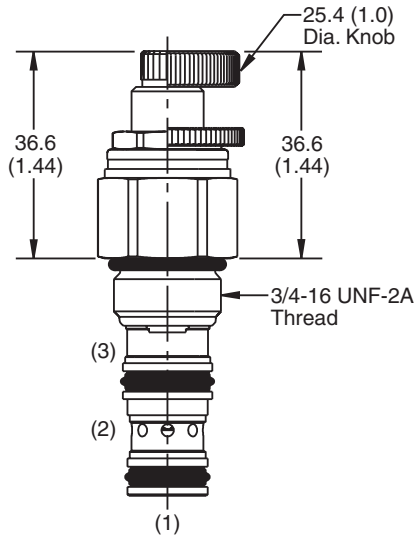

Screw/Knob Version

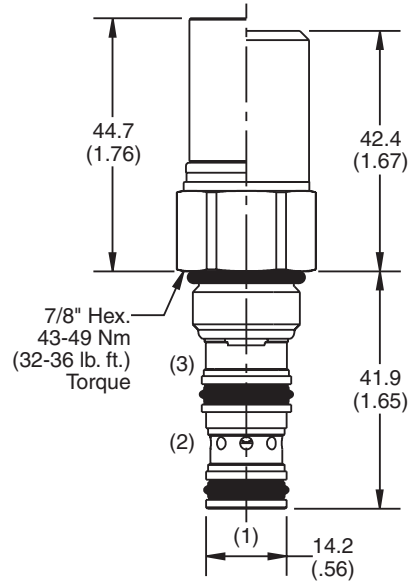

Fixed Cap/Tamper Resistant Version

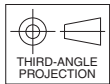

Ordering Information

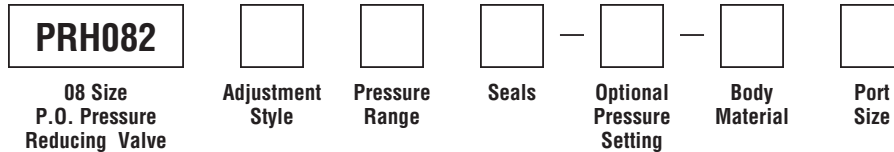

Code	Adjustment Style / Kit No.
F	Fixed style, preset at factory.
K	Knob Adjust (717784-10)
S	Screw Adjust
T	Tamper Resistant Cap (717943)

Code	Seals / Kit No.
Omit	"D"-Ring / (SK08-3)
N	Nitrile / (SK08-3N)
V	Fluorocarbon / (SK08-3V)

Code	Body Material
Omit	Steel
A	Aluminum

Code	Pressure Range
10	6.9 - 69 Bar (100 - 1000 PSI) Standard Setting: 34.5 Bar (500 PSI)
20	6.9 - 138 Bar (100 - 2000 PSI) Standard Setting: 69 Bar (1000 PSI)
30	13.8 - 207 Bar (200 - 3000 PSI) Standard Setting: 103.5 Bar (1500 PSI)
50	13.8 - 345 Bar (200 - 5000 PSI) Standard Setting: 172.4 Bar (2500 PSI)

Optional Pressure Setting
Pressure \pm 10 i.e. 235 = 2350 PSI (Omit if standard setting is used) Setting Range: 100 to 5000 PSI

Code	Port Size	Body Part No.
Omit	Cartridge Only	
4P	1/4" NPTF	(B08-3-*4P)
4T	SAE-4	(B08-3-*4T)
6T	SAE-6	(B08-3-*6T)
6B	3/8" BSPG	(B08-3-*6B)

* Add "A" for aluminum, omit for steel.

NOTE: For settings below 20.7 Bar (300 PSI), flow rating is limited to 11.3 LPM (3 GPM).

- CV**
Check Valves
- SH**
Shuttle Valves
- LM**
Load/Motor Controls
- FC**
Flow Controls
- PC**
Pressure Controls
- LE**
Logic Elements
- DC**
Directional Controls
- MV**
Manual Valves
- SV**
Solenoid Valves
- PV**
Proportional Valves
- CE**
Coils & Electronics
- BC**
Bodies & Cavities
- TD**
Technical Data

Technical Information

- CV** Check Valves
- SH** Shuttle Valves
- LM** Load/Motor Controls
- FC** Flow Controls
- PC** Pressure Controls
- LE** Logic Elements
- DC** Directional Controls
- MV** Manual Valves
- SV** Solenoid Valves
- PV** Proportional Valves
- CE** Coils & Electronics
- BC** Bodies & Cavities
- TD** Technical Data

General Description

Pilot Operated Pressure Reducing Valve. For additional information see Technical Tips on pages PC1-PC6.



Features

- Hardened, precision ground parts for durability
- Low profile adapter for minimal space requirements
- Fully guided poppet for more consistent reseal
- Steel adapters are coated with yellow zinc dichromate for protection from salt spray
- Polyurethane "D"-Ring eliminates backup rings and prevents hydrolysis
- Internal screening protects pilot spring from debris

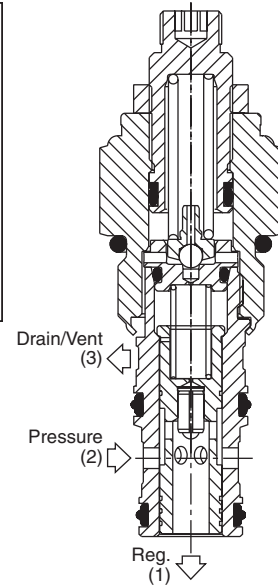
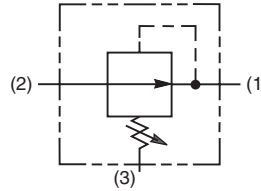
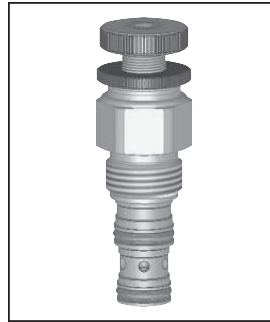

Specifications

Rated Flow	56.3 LPM (15 GPM)
Maximum Inlet Pressure	380 Bar (5500 PSI)
Maximum Pressure Setting	350 Bar (5000 PSI)
Maximum Tank Pressure	350 Bar (5000 PSI)
Maximum Drain Flow	0.94 LPM (0.25 GPM)
Cartridge Material	All parts steel. All operating parts hardened steel.
Operating Temp. Range/Seals	-45°C to +93.3°C ("D"-Ring) (-50°F to +200°F) -31.7°C to +121.1°C (Fluorocarbon) (-25°F to +250°F)
Fluid Compatibility/ Viscosity	Mineral-based or synthetic with lubricating properties at viscosities of 45 to 2000 SSU (6 to 420 cSt)
Filtration	ISO Code 16/13, SAE Class 4 or better
Approx. Weight	.23 kg (0.5 lbs.)
Cavity	C10-3 (See BC Section for more details)
Form Tool	Rougher NTF10-3R Finisher NFT10-3F

Performance Curves

Flow vs. Pressure (Through cartridge only)

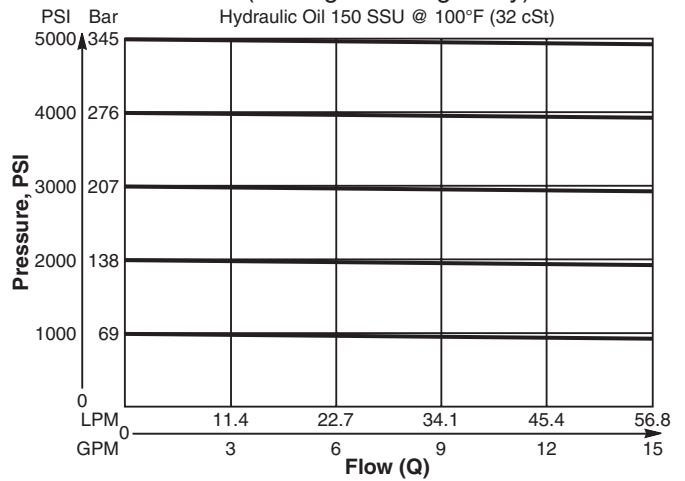

Pressure vs. Flow (Through cartridge only)

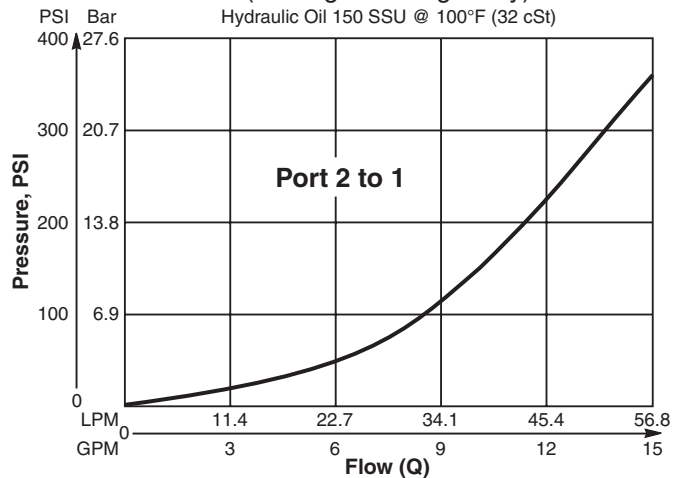

Dimensions Millimeters (Inches)

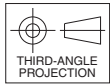
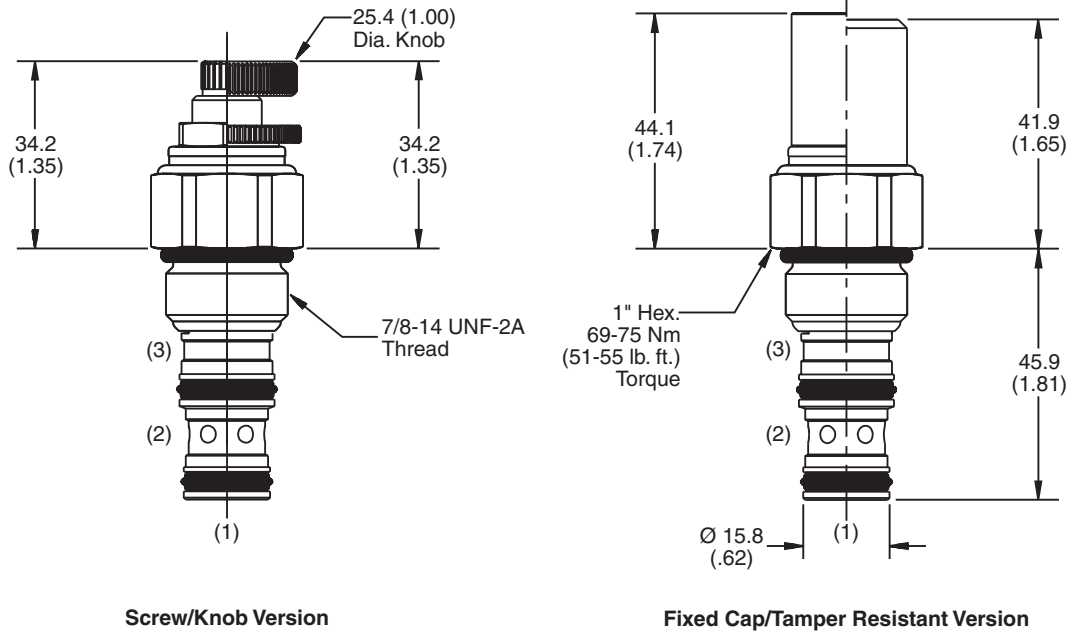

Screw/Knob Version

Fixed Cap/Tamper Resistant Version

Ordering Information

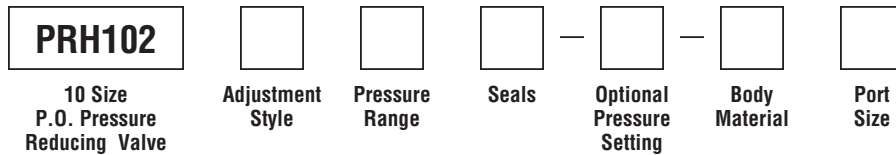

Code	Adjustment Style / Kit No.
F	Fixed style, preset at factory.
K	Knob Adjust (717784-10)
S	Screw Adjust
T	Tamper Resistant Cap (718083)

Code	Seals / Kit No.
Omit	"D"-Ring / (SK10-3)
N	Nitrile / (SK10-3N)
V	Fluorocarbon / (SK10-3V)

Code	Body Material
Omit	Steel
A	Aluminum

Code	Pressure Range
03	6.9 - 34.5 Bar (100 - 500 PSI) Standard Setting: 17.2 Bar (250 PSI)
10	13.7 - 69 Bar (200 - 1000 PSI) Standard Setting: 34.5 Bar (500 PSI)
20	27 - 138 Bar (400 - 2000 PSI) Standard Setting: 69 Bar (1000 PSI)
30	41.4 - 207 Bar (600 - 3000 PSI) Standard Setting: 103.5 Bar (1500 PSI)
50	82.8 - 345 Bar (1200 - 5000 PSI) Standard Setting: 172.4 Bar (2500 PSI)

Optional Pressure Setting	
Pressure	± 10
	i.e. 235 = 2350 PSI
	(Omit if standard setting is used)
Setting Range:	100 to 5000 PSI

Code	Port Size	Body Part No.
Omit	Cartridge Only	
4P	1/4" NPTF	(B10-3-*4P)
6P	3/8" NPTF	(B10-3-*6P)
8P	1/2" NPTF	(B10-3-*8P)
6T	SAE-6	(B10-3-*6T)
8T	SAE-8	(B10-3-*8T)
6B	3/8" BSPG	(B10-3-6B)†
8B	1/2" BSPG	(B10-3-*8B)

* Add "A" for aluminum, omit for steel.
 † Steel Body only.

NOTE: For settings below 20.7 Bar (300 PSI), flow rating is limited to 11.3 LPM (3 GPM).

- CV
Check Valves
- SH
Shuttle Valves
- LM
Load/Motor Controls
- FC
Flow Controls
- PC
Pressure Controls
- LE
Logic Elements
- DC
Directional Controls
- MV
Manual Valves
- SV
Solenoid Valves
- PV
Proportional Valves
- CE
Coils & Electronics
- BC
Bodies & Cavities
- TD
Technical Data

Technical Information

- CV** Check Valves
- SH** Shuttle Valves
- LM** Load/Motor Controls
- FC** Flow Controls
- PC** Pressure Controls
- LE** Logic Elements
- DC** Directional Controls
- MV** Manual Valves
- SV** Solenoid Valves
- PV** Proportional Valves
- CE** Coils & Electronics
- BC** Bodies & Cavities
- TD** Technical Data

General Description

Pilot Operated Pressure Reducing Valve. For additional information see Technical Tips on pages PC1-PC6.

Features

- Hardened, precision ground parts for durability
- High accuracy, pilot operation design
- Ball-type pilot for added stability
- All external parts have yellow zinc dichromate. This coating is ideal for salt spray applications.

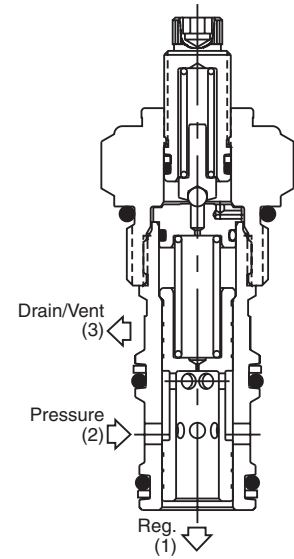
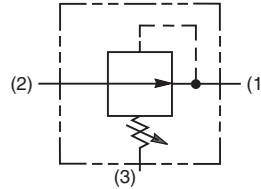
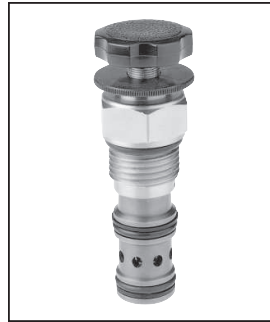

Specifications

Rated Flow	113.7 LPM (30 GPM)
Maximum Inlet Pressure	380 Bar (5500 PSI)
Maximum Pressure Setting	350 Bar (5000 PSI)
Maximum Tank Pressure	350 Bar (5000 PSI)
Maximum Drain Flow	1.9 LPM (0.50 GPM)
Cartridge Material	All parts steel. All operating parts hardened steel.
Operating Temp. Range (Ambient)	-40°C to +93.3°C (Nitrile) (-40°F to +200°F) -31.7°C to +121.1°C (Fluorocarbon) (-25°F to +250°F)
Fluid Compatibility/ Viscosity	Mineral-based or synthetic with lubricating properties at viscosities of 45 to 2000 SSU (6 to 420 cSt)
Filtration	ISO Code 16/13, SAE Class 4 or better
Approx. Weight	.27 kg (0.6 lbs.)
Cavity	C12-3 (See BC Section for more details)
Form Tool	Rougher NFT12-3R Finisher NFT12-3F

Performance Curve

Flow vs. Pressure

(Pressure rise through cartridge only)

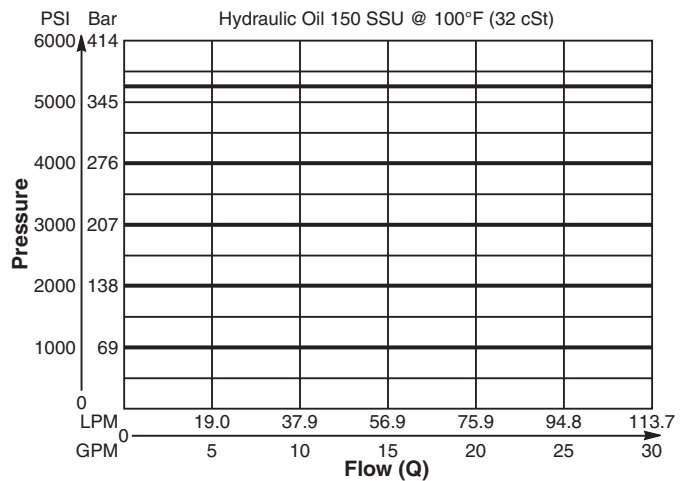

Dimensions Millimeters (Inches)

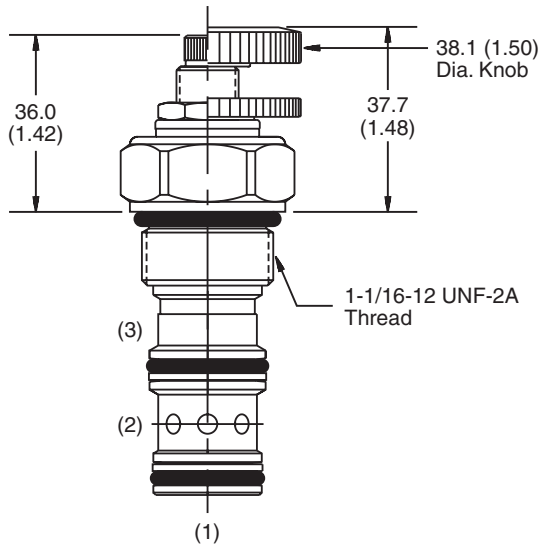

Screw/Knob Version

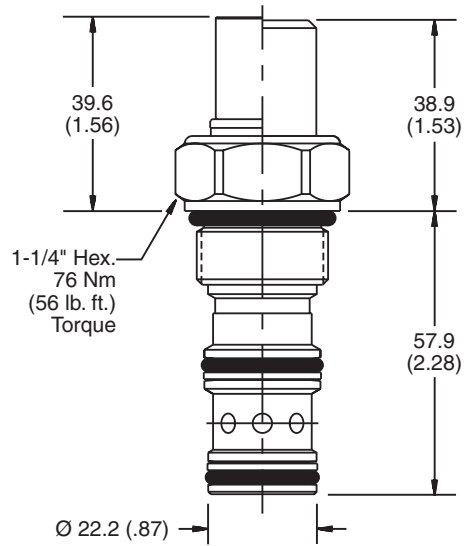

Fixed Cap/Tamper Resistant Version

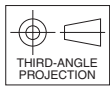

Ordering Information

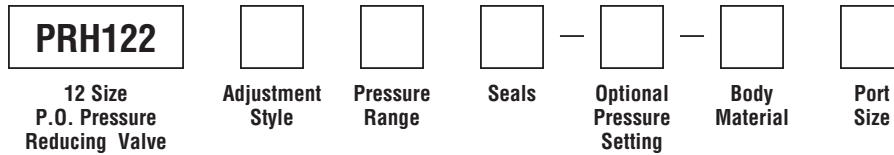

Code	Adjustment Style / Kit No.
F	Fixed style, preset at factory.
K	Knob Adjust (717784-15)
S	Screw Adjust
T	Tamper Resistant Cap (717785)

Code	Seals / Kit No.
Omit	Nitrile / (SK12-3)
V	Fluorocarbon / (SK12-3V)

Code	Body Material
Omit	Steel
A	Aluminum

Code	Pressure Range
10	6.9 - 69 Bar (100 - 1000 PSI) Standard Setting: 34.5 Bar (500 PSI)
20	13.8 - 138 Bar (200 - 2000 PSI) Standard Setting: 69 Bar (1000 PSI)
30	20.7 - 207 Bar (300 - 3000 PSI) Standard Setting: 103.5 Bar (1500 PSI)
50	34.5 - 345 Bar (500 - 5000 PSI) Standard Setting: 172.4 Bar (2500 PSI)

Optional Pressure Setting
Pressure \pm 10 i.e. 235 = 2350 PSI (Omit is standard setting is used) Setting Range: 100 to 5000 PSI

Code	Port Size	Body Part No.
Omit	Cartridge Only	
12T	SAE-12	(B12-3-*12T)
8B	1/2" BSPG	(B12-3-8B)†

* Add "A" for aluminum, omit for steel.
 † Steel Body only.

- CV**
Check Valves
- SH**
Shuttle Valves
- LM**
Load/Motor Controls
- FC**
Flow Controls
- PC**
Pressure Controls
- LE**
Logic Elements
- DC**
Directional Controls
- MV**
Manual Valves
- SV**
Solenoid Valves
- PV**
Proportional Valves
- CE**
Coils & Electronics
- BC**
Bodies & Cavities
- TD**
Technical Data

Technical Information

- CV** Check Valves
- SH** Shuttle Valves
- LM** Load/Motor Controls
- FC** Flow Controls
- PC** Pressure Controls
- LE** Logic Elements
- DC** Directional Controls
- MV** Manual Valves
- SV** Solenoid Valves
- PV** Proportional Valves
- CE** Coils & Electronics
- BC** Bodies & Cavities
- TD** Technical Data

General Description

Pilot Operated Pressure Reducing Valve. For additional information see Technical Tips on pages PC1-PC6.

Features

- Hardened, precision ground parts for durability
- High accuracy, pilot operation design
- Ball-type pilot for added stability
- All external parts have yellow zinc dichromate. This coating is ideal for salt spray applications.

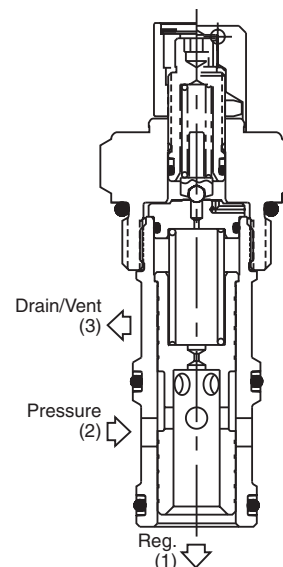
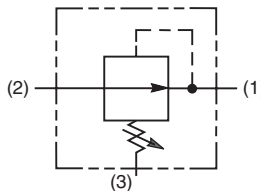
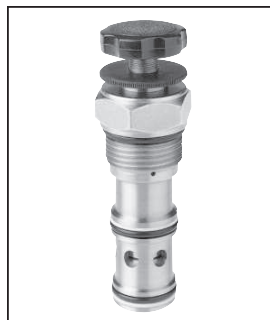

Specifications

Rated Flow	150 LPM (40 GPM)
Maximum Inlet Pressure	380 Bar (5500 PSI)
Maximum Pressure Setting	350 Bar (5000 PSI)
Maximum Tank Pressure	350 Bar (5000 PSI)
Maximum Drain Flow	0.94 LPM (0.25 GPM)
Cartridge Material	All parts steel. All operating parts hardened steel.
Operating Temp. Range/Seals	-40°C to +93.3°C (Nitrile) (-40°F to +200°F) -31.7°C to +121.1°C (Fluorocarbon) (-25°F to +250°F)
Fluid Compatibility/Viscosity	Mineral-based or synthetic with lubricating properties at viscosities of 45 to 2000 SSU (6 to 420 cSt)
Filtration	ISO Code 16/13, SAE Class 4 or better
Approx. Weight	0.9 kg (2.0 lbs.)
Cavity	C16-3 (See BC Section for more details)
Form Tool	Rougher NTF16-3R Finisher NFT16-3F

Performance Curve

Flow vs. Pressure

(Pressure rise through cartridge only)

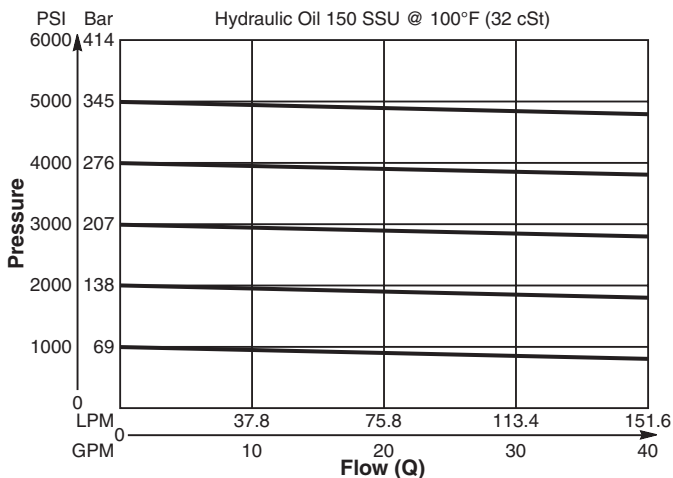

Dimensions Millimeters (Inches)

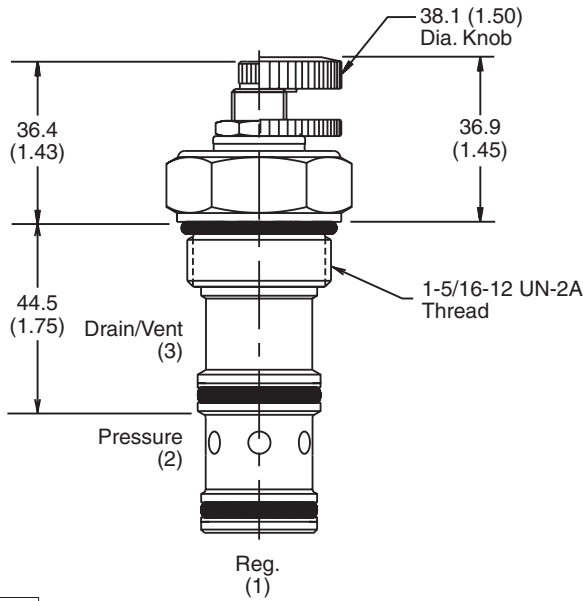

Screw/Knob Version

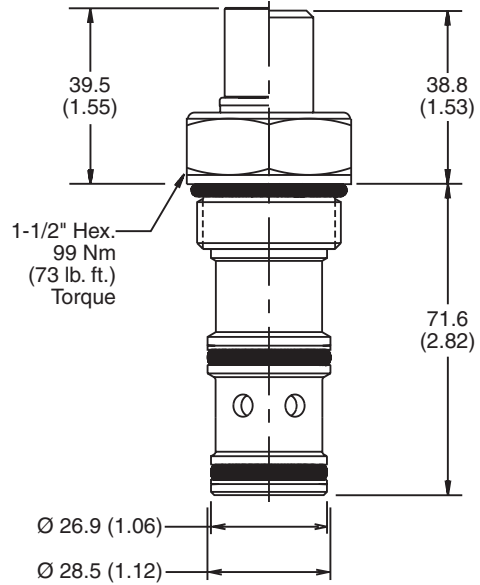

Fixed Cap/Tamper Resistant Version

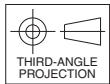

Ordering Information

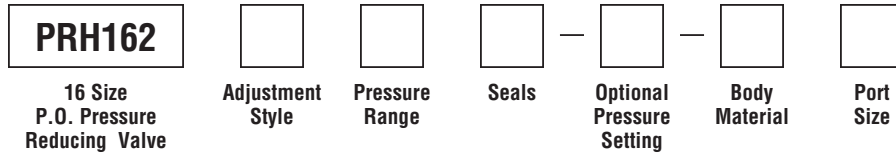

Code	Adjustment Style / Kit No.
F	Fixed style, preset at factory.
K	Knob Adjust (717784-15)
S	Screw Adjust
T	Tamper Resistant Cap (717785)

Code	Seals / Kit No.
Omit	Nitrile / (SK16-3)
V	Fluorocarbon / (SK16-3V)

Code	Body Material
Omit	Steel
A	Aluminum

Code	Pressure Range
10	6.9 - 69 Bar (100 - 1000 PSI) Standard Setting: 34.5 Bar (500 PSI)
20	13.8 - 138 Bar (200 - 2000 PSI) Standard Setting: 69 Bar (1000 PSI)
30	20.7 - 207 Bar (300 - 3000 PSI) Standard Setting: 103.5 Bar (1500 PSI)
50	34.5 - 345 Bar (500 - 5000 PSI) Standard Setting: 172.4 Bar (2500 PSI)

Optional Pressure Setting
Pressure \pm 10 i.e. 235 = 2350 PSI (Omit if standard setting is used) Setting Range: 100 to 5000 PSI

Code	Port Size	Body Part No.
Omit	Cartridge Only	
12T	SAE-12	(B16-3-*12T)
16T	SAE-16	(B16-3-*16T)

* Add "A" for aluminum, omit for steel.

Technical Information

- CV** Check Valves
- SH** Shuttle Valves
- LM** Load/Motor Controls
- FC** Flow Controls
- PC** Pressure Controls
- LE** Logic Elements
- DC** Directional Controls
- MV** Manual Valves
- SV** Solenoid Valves
- PV** Proportional Valves
- CE** Coils & Electronics
- BC** Bodies & Cavities
- TD** Technical Data

General Description

Pilot Operated Pressure Reducing/Relieving Valve. For additional information see Technical Tips on pages PC1-PC6.



Features

- Hardened, precision ground parts for durability
- Low profile adapter for minimal space requirements
- Fully guided pilot for more consistent reseal
- Steel adapters are coated with yellow zinc dichromate for protection from salt spray
- Polyurethane "D"-Ring eliminates backup rings and prevents hydrolysis
- Internal screening protects pilot spring from debris

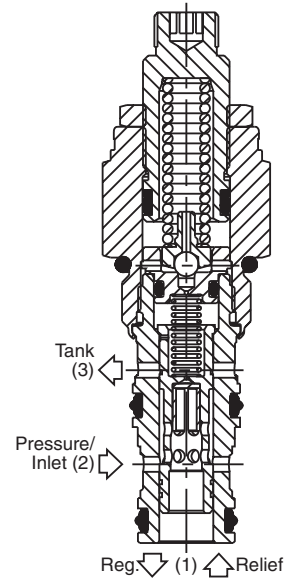
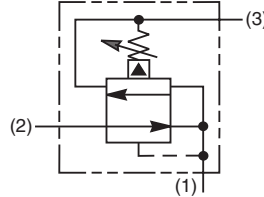

Specifications

Rated Flow	30 LPM (8 GPM)
Maximum Inlet Pressure	380 Bar (5500 PSI)
Maximum Pressure Setting	350 Bar (5000 PSI)
Maximum Tank Pressure	350 Bar (5000 PSI)
Maximum Drain Flow	0.56 LPM (0.15 GPM)
Cartridge Material	All parts steel. All operating parts hardened steel.
Operating Temp. Range/Seals	-45°C to +93.3°C ("D"-Ring) (-50°F to +200°F) -31.7°C to +121.1°C (Fluorocarbon) (-25°F to +250°F)
Fluid Compatibility/Viscosity	Mineral-based or synthetic with lubricating properties at viscosities of 45 to 2000 SSU (6 to 420 cSt)
Filtration	ISO Code 16/13, SAE Class 4 or better
Approx. Weight	.11 kg (.25 lbs.)
Cavity	C08-3 (See BC Section for more details)
Form Tool	Rougher NTF08-3R Finisher NFT08-3F

Performance Curves

Flow vs. Regulated Pressure (Through cartridge only)

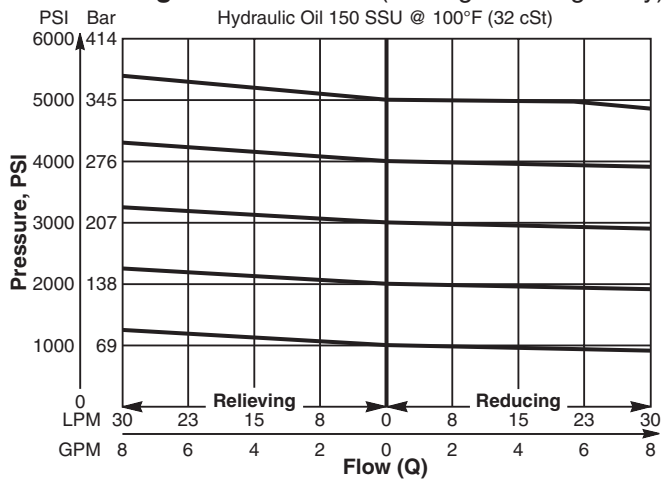

Flow vs. Pressure Drop (Through cartridge only)

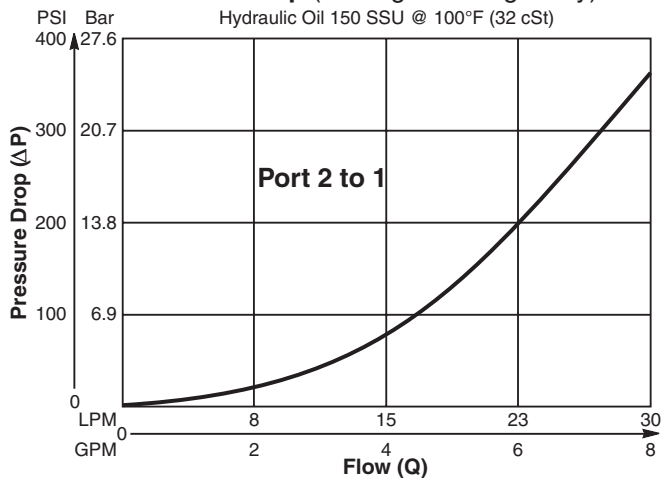

Dimensions Millimeters (Inches)

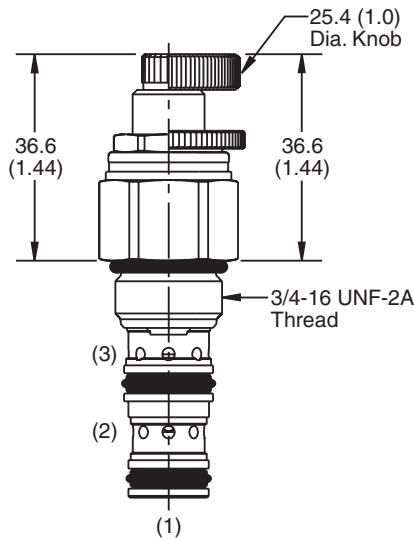

Screw/Knob Version

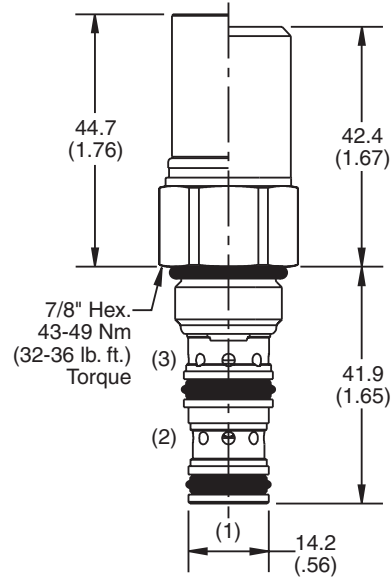

Fixed Cap/Tamper Resistant Version

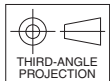

Ordering Information

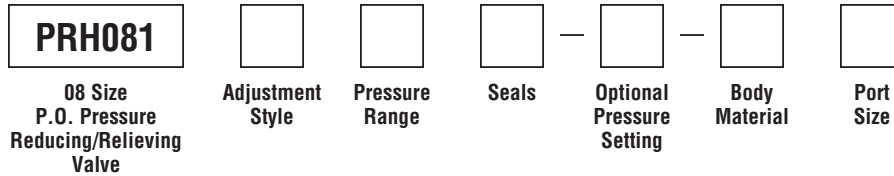

Code	Adjustment Style / Kit No.
F	Fixed style, preset at factory.
K	Knob Adjust (717784-10)
S	Screw Adjust
T	Tamper Resistant Cap (717943)

Code	Seals / Kit No.
Omit	"D"-Ring / (SK08-3)
N	Nitrile / (SK08-3N)
V	Fluorocarbon / (SK08-3V)

Code	Body Material
Omit	Steel
A	Aluminum

Code	Pressure Range
10	6.9 - 69 Bar (100 - 1000 PSI) Standard Setting: 34.5 Bar (500 PSI)
20	6.9 - 138 Bar (100 - 2000 PSI) Standard Setting: 69 Bar (1000 PSI)
30	13.8 - 207 Bar (200 - 3000 PSI) Standard Setting: 103.5 Bar (1500 PSI)
50	13.8 - 345 Bar (200 - 5000 PSI) Standard Setting: 172.4 Bar (2500 PSI)

Optional Pressure Setting
Pressure \pm 10 i.e. 235 = 2350 PSI (Omit if standard setting is used) Setting Range: 100 to 5000 PSI

Code	Port Size	Body Part No.
Omit	Cartridge Only	
4P	1/4" NPTF	(B08-3-*4P)
4T	SAE-4	(B08-3-*4T)
6T	SAE-6	(B08-3-*6T)
6B	3/8" BSPG	(B08-3-*6B)

* Add "A" for aluminum, omit for steel.

NOTE: For settings below 20.7 Bar (300 PSI), flow rating is limited to 11.3 LPM (3 GPM).

- CV**
Check Valves
- SH**
Shuttle Valves
- LM**
Load/Motor Controls
- FC**
Flow Controls
- PC**
Pressure Controls
- LE**
Logic Elements
- DC**
Directional Controls
- MV**
Manual Valves
- SV**
Solenoid Valves
- PV**
Proportional Valves
- CE**
Coils & Electronics
- BC**
Bodies & Cavities
- TD**
Technical Data

Technical Information

- CV** Check Valves
- SH** Shuttle Valves
- LM** Load/Motor Controls
- FC** Flow Controls
- PC** Pressure Controls
- LE** Logic Elements
- DC** Directional Controls
- MV** Manual Valves
- SV** Solenoid Valves
- PV** Proportional Valves
- CE** Coils & Electronics
- BC** Bodies & Cavities
- TD** Technical Data

General Description

Pilot Operated Pressure Reducing/Relieving Valve. For additional information see Technical Tips on pages PC1-PC6.



Features

- Hardened, precision ground parts for durability
- Low profile adapter for minimal space requirements
- Fully guided poppet for more consistent reseal
- Steel adapters are coated with yellow zinc dichromate for protection from salt spray
- Polyurethane "D"-Ring eliminates backup rings and prevents hydrolysis
- Internal screening protects pilot spring from debris

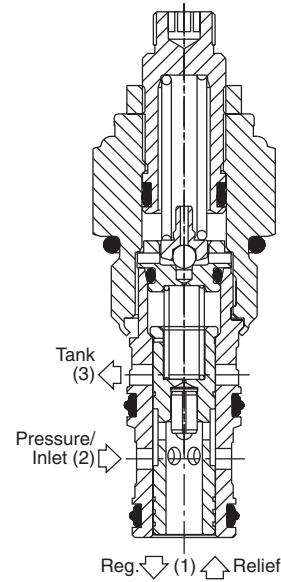
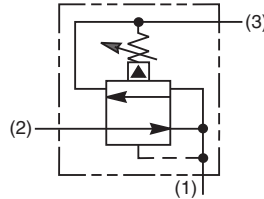

Specifications

Rated Flow	56.3 LPM (15 GPM)
Maximum Inlet Pressure	380 Bar (5500 PSI)
Maximum Pressure Setting	350 Bar (5000 PSI)
Maximum Tank Pressure	350 Bar (5000 PSI)
Maximum Drain Flow	0.94 LPM (0.25 GPM)
Cartridge Material	All parts steel. All operating parts hardened steel.
Operating Temp. Range/Seals	-45°C to +93.3°C ("D"-Ring) (-50°F to +200°F) -31.7°C to +121.1°C (Fluorocarbon) (-25°F to +250°F)
Fluid Compatibility/Viscosity	Mineral-based or synthetic with lubricating properties at viscosities of 45 to 2000 SSU (6 to 420 cSt)
Filtration	ISO Code 16/13, SAE Class 4 or better
Approx. Weight	.23 kg (0.5 lbs.)
Cavity	C10-3 (See BC Section for more details)
Form Tool	Rougher NTF10-3R Finisher NFT10-3F

Performance Curves

Flow vs. Regulated Pressure (Through cartridge only)

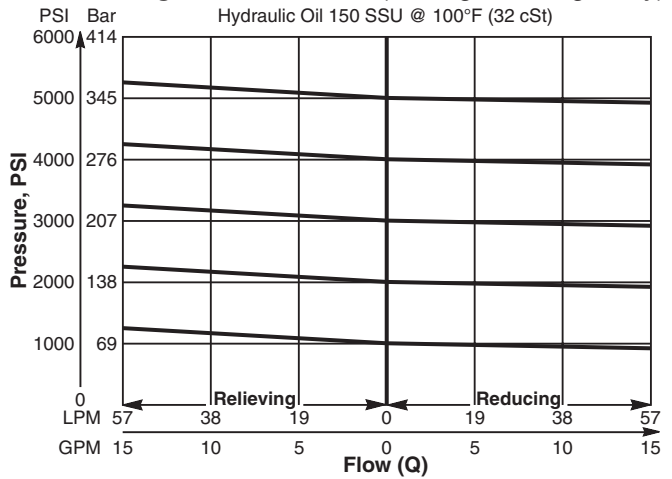

Pressure vs. Flow (Through cartridge only)

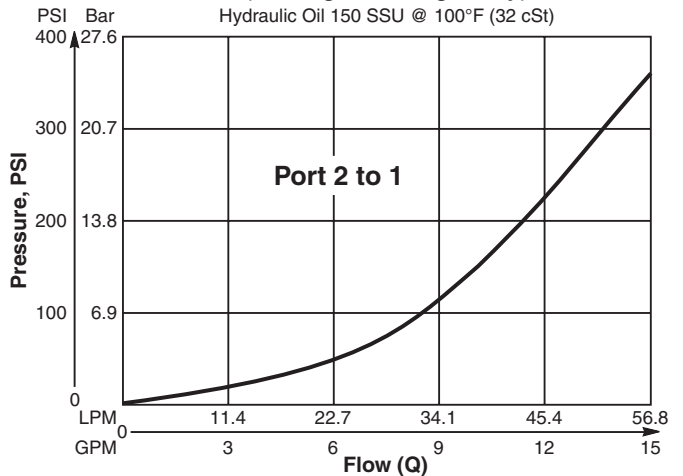

Dimensions Millimeters (Inches)

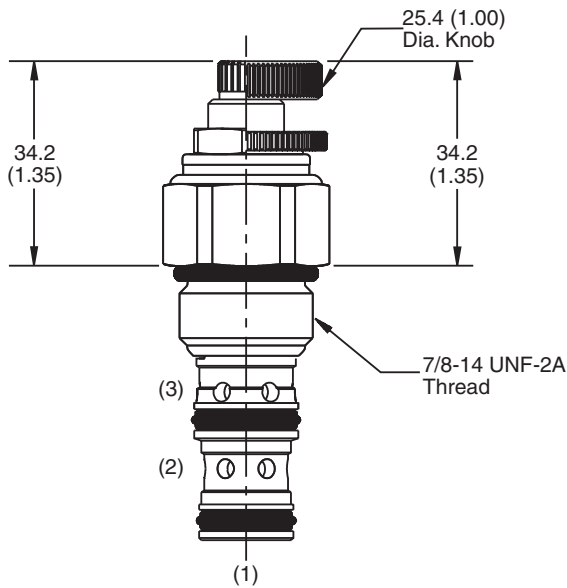

Screw/Knob Version

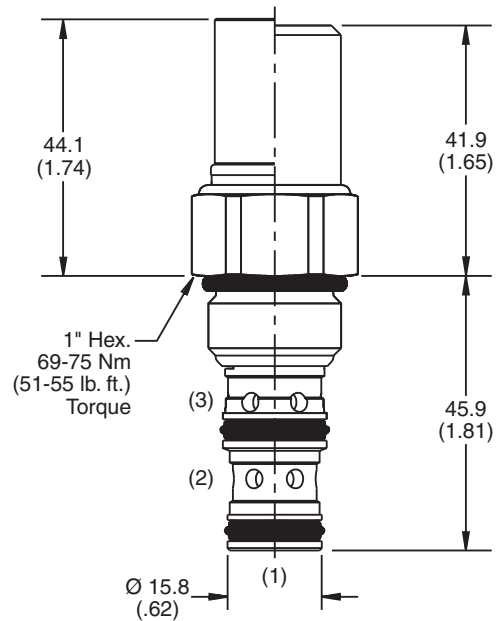

Fixed Cap/Tamper Resistant Version

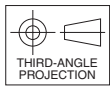

Ordering Information

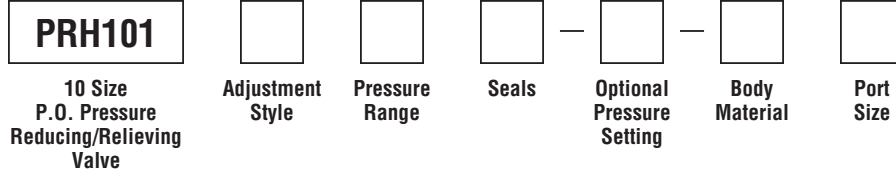

Code	Adjustment Style / Kit No.
F	Fixed style, preset at factory.
K	Knob Adjust (717784-10)
S	Screw Adjust
T	Tamper Resistant Cap (718083)

Code	Seals / Kit No.
Omit	"D"-Ring / (SK10-3)
N	Nitrile / (SK10-3N)
V	Fluorocarbon / (SK10-3V)

Code	Body Material
Omit	Steel
A	Aluminum

Code	Pressure Range
03	6.9 - 34.5 Bar (100 - 500 PSI) Standard Setting: 17.2 Bar (250 PSI)
10	13.7 - 69 Bar (200 - 1000 PSI) Standard Setting: 34.5 Bar (500 PSI)
20	27 - 138 Bar (400 - 2000 PSI) Standard Setting: 69 Bar (1000 PSI)
30	41.4 - 207 Bar (600 - 3000 PSI) Standard Setting: 103.5 Bar (1500 PSI)
50	82.8 - 345 Bar (1200 - 5000 PSI) Standard Setting: 172.4 Bar (2500 PSI)

Optional Pressure Setting
Pressure \pm 10 i.e. 235 = 2350 PSI (Omit if standard setting is used) Setting Range: 100 to 5000 PSI

Code	Port Size	Body Part No.
Omit	Cartridge Only	
4P	1/4" NPTF	(B10-3-*4P)
6P	3/8" NPTF	(B10-3-*6P)
8P	1/2" NPTF	(B10-3-*8P)
6T	SAE-6	(B10-3-*6T)
8T	SAE-8	(B10-3-*8T)
6B	3/8" BSPG	(B10-3-6B)†
8B	1/2" BSPG	(B10-3-*8P)

* Add "A" for aluminum, omit for steel.
 † Steel body only.

NOTE: For settings below 20.7 Bar (300 PSI), flow rating is limited to 11.3 LPM (3 GPM).

- CV** Check Valves
- SH** Shuttle Valves
- LM** Load/Motor Controls
- FC** Flow Controls
- PC** Pressure Controls
- LE** Logic Elements
- DC** Directional Controls
- MV** Manual Valves
- SV** Solenoid Valves
- PV** Proportional Valves
- CE** Coils & Electronics
- BC** Bodies & Cavities
- TD** Technical Data

Technical Information

- CV** Check Valves
- SH** Shuttle Valves
- LM** Load/Motor Controls
- FC** Flow Controls
- PC** Pressure Controls
- LE** Logic Elements
- DC** Directional Controls
- MV** Manual Valves
- SV** Solenoid Valves
- PV** Proportional Valves
- CE** Coils & Electronics
- BC** Bodies & Cavities
- TD** Technical Data

General Description

Pilot Operated Pressure Reducing/Relieving Valve. For additional information see Technical Tips on pages PC1-PC6.

Features

- Hardened, precision ground parts for durability
- Ball-type pilot for added stability
- Full capacity reducing/relieving
- Performs job of two separate valves in one
- All external parts have yellow zinc dichromate. This coating is ideal for salt spray applications.

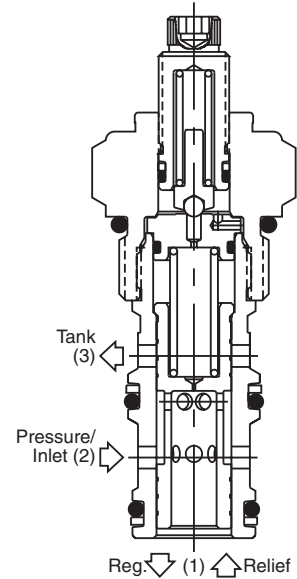
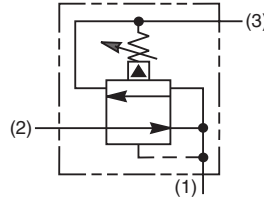

Specifications

Rated Flow	113.7 LPM (30 GPM)
Maximum Inlet Pressure	380 Bar (5500 PSI)
Maximum Pressure Setting	350 Bar (5000 PSI)
Maximum Tank Pressure	350 Bar (5000 PSI)
Maximum Drain Flow	0.94 LPM (0.25 GPM)
Cartridge Material	All parts steel. All operating parts hardened steel.
Operating Temp. Range/Seals	-40°C to +93.3°C (Nitrile) (-40°F to +200°F) -31.7°C to +121.1°C (Fluorocarbon) (-25°F to +250°F)
Fluid Compatibility/Viscosity	Mineral-based or synthetic with lubricating properties at viscosities of 45 to 2000 SSU (6 to 420 cSt)
Filtration	ISO Code 16/13, SAE Class 4 or better
Approx. Weight	.27 kg (0.6 lbs.)
Cavity	C12-3 (See BC Section for more details)
Form Tool	Rougher NTF12-3R Finisher NFT12-3F

Performance Curve

Flow vs. Regulated Pressure

(Pressure rise through cartridge only)

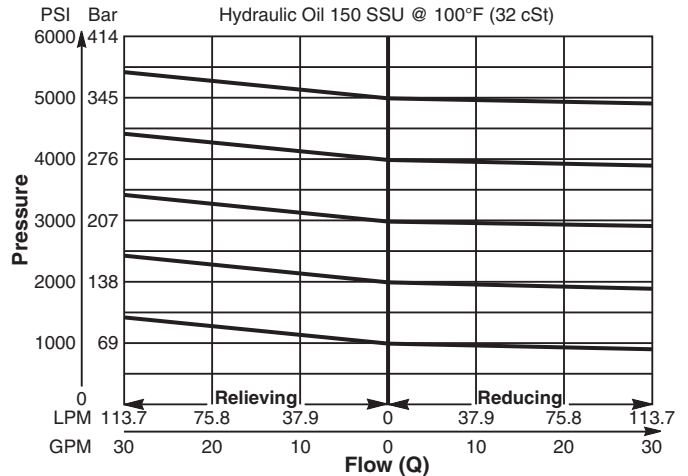

Dimensions Millimeters (Inches)

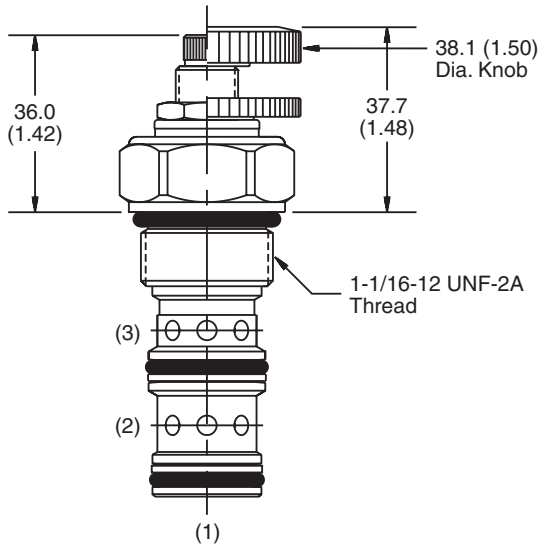

Screw/Knob Version

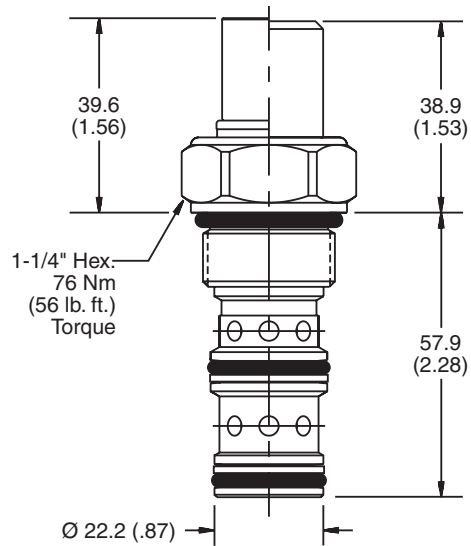

Fixed Cap/Tamper Resistant Version

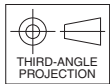

Ordering Information

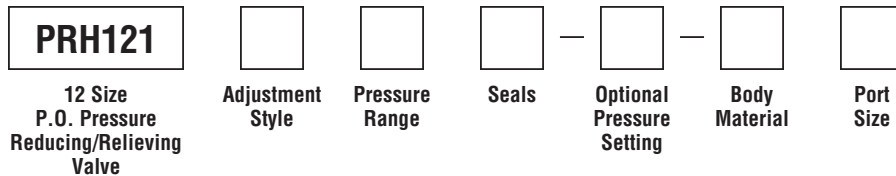

Code	Adjustment Style / Kit No.
F	Fixed style, preset at factory.
K	Knob Adjust (717784-15)
S	Screw Adjust
T	Tamper Resistant Cap (717785)

Code	Seals / Kit No.
Omit	Nitrile / (SK12-3)
V	Fluorocarbon / (SK12-3V)

Code	Body Material
Omit	Steel
A	Aluminum

Code	Pressure Range
10	6.9 - 69 Bar (100 - 1000 PSI) Standard Setting: 34.5 Bar (500 PSI)
20	13.8 - 138 Bar (200 - 2000 PSI) Standard Setting: 69 Bar (1000 PSI)
30	20.7 - 207 Bar (300 - 3000 PSI) Standard Setting: 103.5 Bar (1500 PSI)
50	34.5 - 345 Bar (500 - 5000 PSI) Standard Setting: 172.4 Bar (2500 PSI)

Optional Pressure Setting
Pressure \pm 10 i.e. 235 = 2350 PSI (Omit if standard setting is used) Setting Range: 100 to 5000 PSI

Code	Port Size	Body Part No.
Omit	Cartridge Only	
8T	SAE-8	(B12-3-*8T)
12T	SAE-12	(B12-3-*12T)
8B	1/2" BSPG	(B12-3-8B)†

* Add "A" for aluminum, omit for steel.
 † Steel body only.

- CV**
Check Valves
- SH**
Shuttle Valves
- LM**
Load/Motor Controls
- FC**
Flow Controls
- PC**
Pressure Controls
- LE**
Logic Elements
- DC**
Directional Controls
- MV**
Manual Valves
- SV**
Solenoid Valves
- PV**
Proportional Valves
- CE**
Coils & Electronics
- BC**
Bodies & Cavities
- TD**
Technical Data

Technical Information

- CV** Check Valves
- SH** Shuttle Valves
- LM** Load/Motor Controls
- FC** Flow Controls
- PC** Pressure Controls
- LE** Logic Elements
- DC** Directional Controls
- MV** Manual Valves
- SV** Solenoid Valves
- PV** Proportional Valves
- CE** Coils & Electronics
- BC** Bodies & Cavities
- TD** Technical Data

General Description

Pilot Operated Pressure Reducing/Relieving Valve. For additional information see Technical Tips on pages PC1-PC6.

Features

- Hardened, precision ground parts for durability
- Ball-type pilot for added stability
- Full capacity reducing/relieving
- Performs job of two separate valves in one
- All external parts have yellow zinc dichromate. This coating is ideal for salt spray applications.

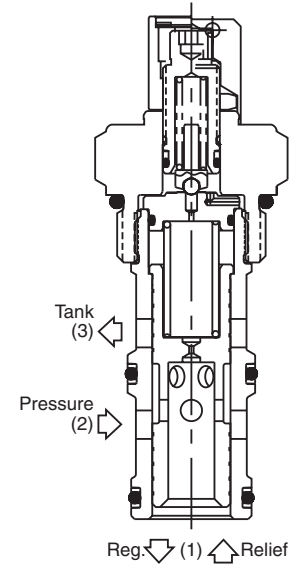
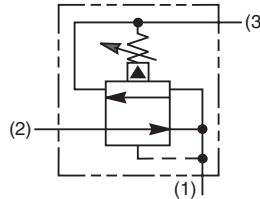

Specifications

Rated Flow	150 LPM (40 GPM)
Maximum Inlet Pressure	380 Bar (5500 PSI)
Maximum Pressure Setting	350 Bar (5000 PSI)
Maximum Tank Pressure	350 Bar (5000 PSI)
Maximum Drain Flow	1.9 LPM (0.5 GPM)
Cartridge Material	All parts steel. All operating parts hardened steel.
Operating Temp. Range/Seals	-40°C to +93.3°C (Nitrile) (-40°F to +200°F) -31.7°C to +121.1°C (Fluorocarbon) (-25°F to +250°F)
Fluid Compatibility/Viscosity	Mineral-based or synthetic with lubricating properties at viscosities of 45 to 2000 SSU (6 to 420 cSt)
Filtration	ISO Code 16/13, SAE Class 4 or better
Approx. Weight	0.9 kg (2.0 lbs.)
Cavity	C16-3 (See BC Section for more details)
Form Tool	Rougher NTF16-3R Finisher NFT16-3F

Performance Curve

Flow vs. Regulated Pressure

(Pressure rise through cartridge only)

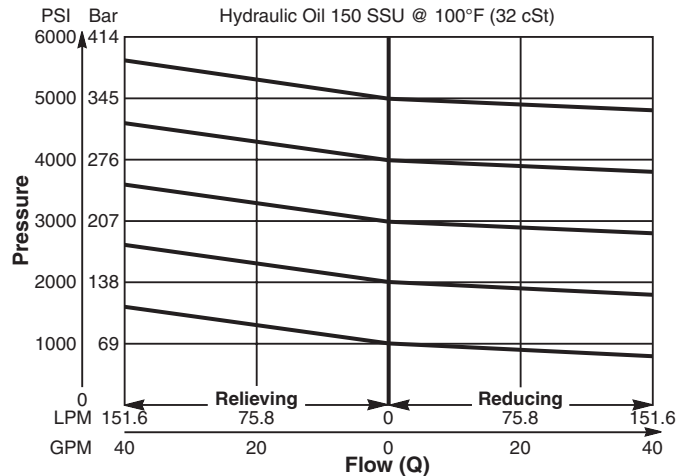

Dimensions Millimeters (Inches)

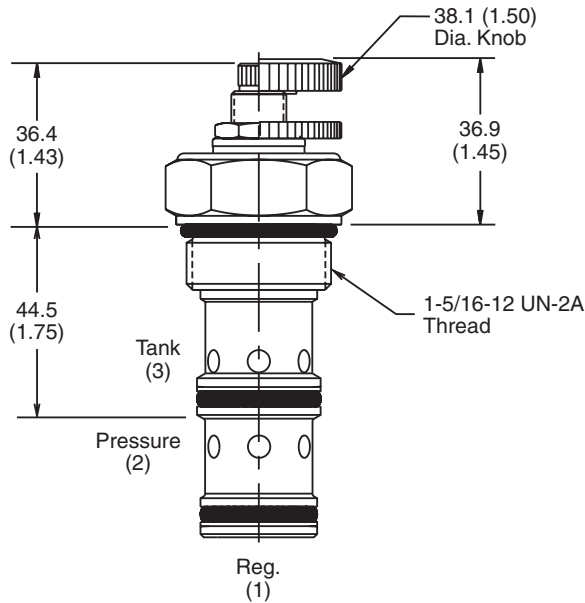

Screw/Knob Version

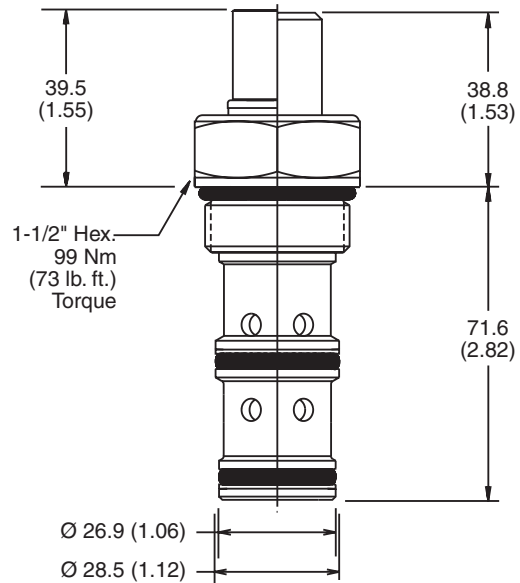

Fixed Cap/Tamper Resistant Version

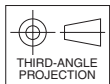

Ordering Information

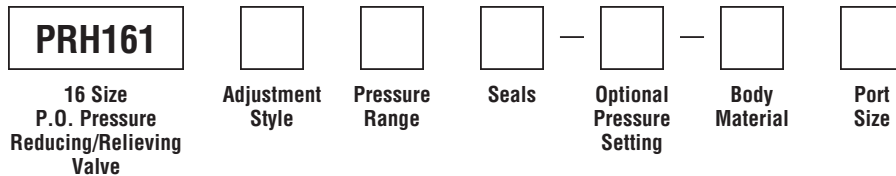

Code	Adjustment Style / Kit No.
F	Fixed style, preset at factory.
K	Knob Adjust (717784-15)
S	Screw Adjust
T	Tamper Resistant Cap (717785)

Code	Seals / Kit No.
Omit	Nitrile / (SK16-3)
V	Fluorocarbon / (SK16-3V)

Code	Body Material
Omit	Steel
A	Aluminum

Code	Pressure Range
10	6.9 - 69 Bar (100 - 1000 PSI) Standard Setting: 34.5 Bar (500 PSI)
20	13.8 - 138 Bar (200 - 2000 PSI) Standard Setting: 69 Bar (1000 PSI)
30	20.7 - 207 Bar (300 - 3000 PSI) Standard Setting: 103.5 Bar (1500 PSI)
50	34.5 - 345 Bar (500 - 5000 PSI) Standard Setting: 172.4 Bar (2500 PSI)

Optional Pressure Setting
Pressure \pm 10 i.e. 235 = 2350 PSI (Omit if standard setting is used) Setting Range: 100 to 5000 PSI

Code	Port Size	Body Part No.
Omit	Cartridge Only	
12T	SAE-12	(B16-3-*12T)
16T	SAE-16	(B16-3-*16T)

* Add "A" for aluminum, omit for steel.

Technical Information

- CV** Check Valves
- SH** Shuttle Valves
- LM** Load/Motor Controls
- FC** Flow Controls
- PC** Pressure Controls
- LE** Logic Elements
- DC** Directional Controls
- MV** Manual Valves
- SV** Solenoid Valves
- PV** Proportional Valves
- CE** Coils & Electronics
- BC** Bodies & Cavities
- TD** Technical Data

General Description

Pilot Operated Pressure Reducing/Relieving Valve with Reverse Flow Check Valve. For additional information see Technical Tips on pages PC1-PC6.

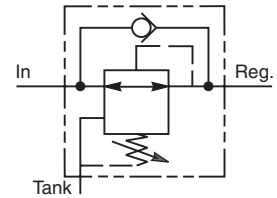

Features

- Hardened, precision ground parts for durability
- Built-in reverse flow check reduces plumbing
- Cartridge design
- All external parts have yellow zinc dichromate. This coating is ideal for salt spray applications.

Specifications

Rated Flow	56.3 LPM (15 GPM)
Maximum Inlet Press. (Reducing/Relieving mode)	380 Bar (5500 PSI)
Maximum Setting Press. (Reducing/Relieving mode)	350 Bar (5000 PSI)
Maximum Inlet Press. (Free Flow Check mode)	380 Bar (5500 PSI)
Maximum Drain Flow	0.94 LPM (0.25 GPM)
Cartridge Material	All parts steel. All operating parts hardened steel.
Body Material	Steel
Operating Temp. Range/Seals	-45°C to +93.3°C ("D"-Ring (-50°F to +200°F) -31.7°C to +121.1°C (Fluorocarbon) (-25°F to +250°F)
Fluid Compatibility/Viscosity	Mineral-based or synthetic with lubricating properties at viscosities of 45 to 2000 SSU (6 to 420 cSt)
Filtration	ISO Code 16/13, SAE Class 4 or better
Approx. Weight	1.0 kg (2.2 lbs.)

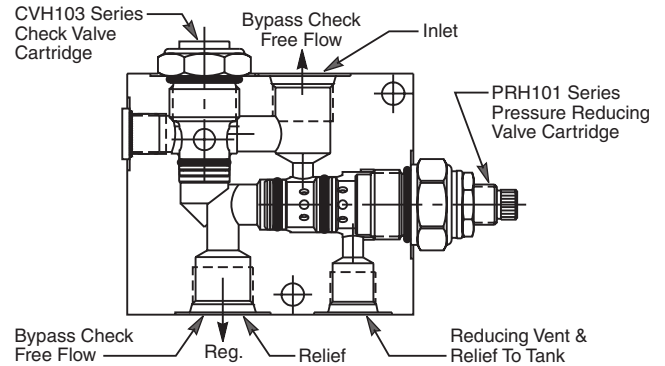

Performance Curve
Flow vs. Inlet Pressure

(Pressure rise through cartridge only)

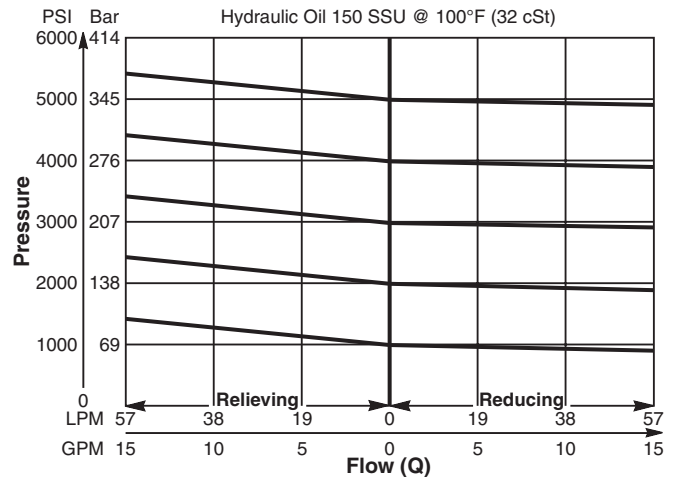

Dimensions Millimeters (Inches)

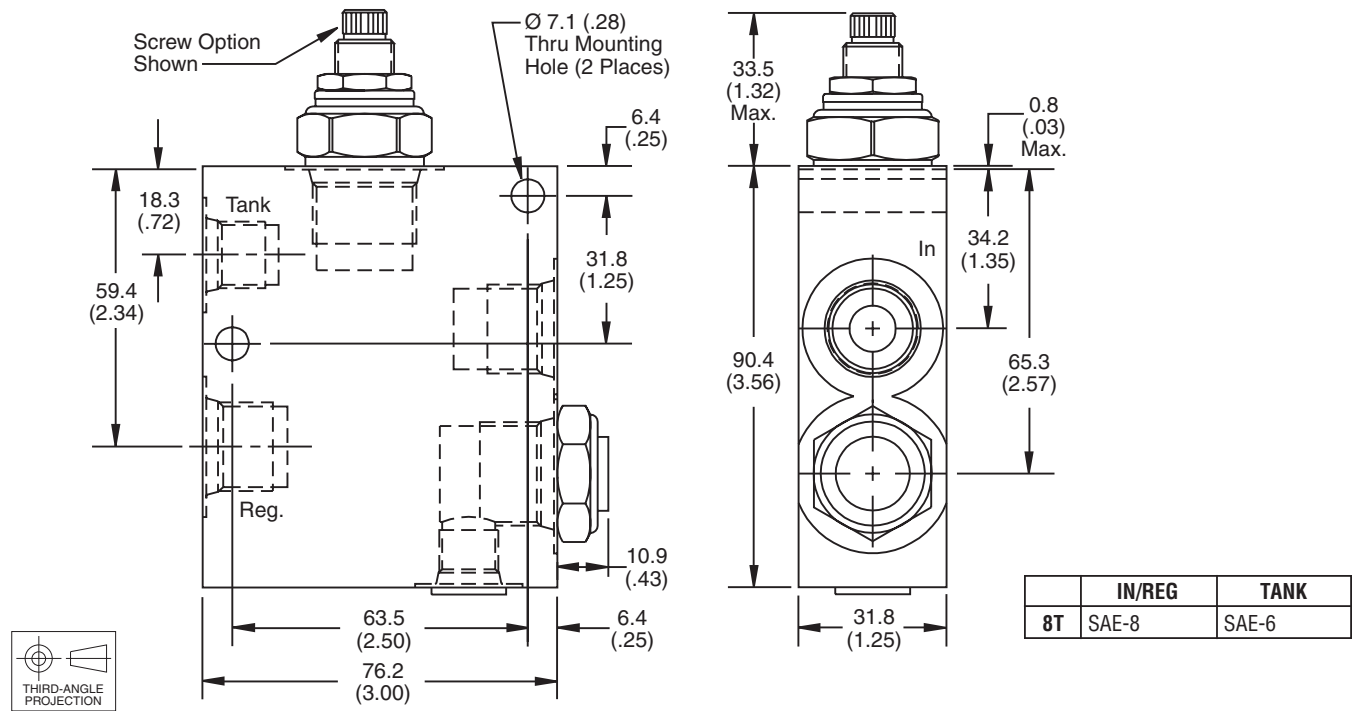

Ordering Information

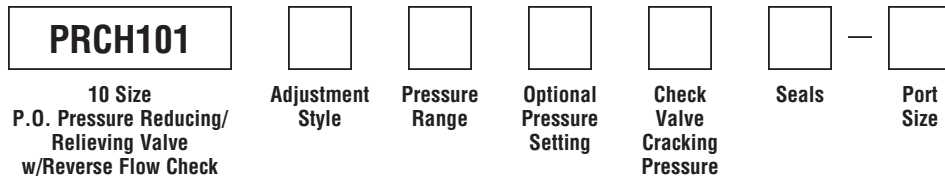

Code	Adjustment Style / Kit No.
F	Fixed style, preset at factory.
K	Knob Adjust (717784-10)
S	Screw Adjust
T	Tamper Resistant Cap (718083)

Optional Pressure Setting	
Pressure	± 10 i.e. 235 = 2350 PSI (Omit if standard setting is used)
Setting Range:	100 to 5000 PSI
All settings at crack pressure,	approximately .95 LPM (.25 GPM)

Code	Seals
Omit	"D"-Ring
N	Nitrile
V	Fluorocarbon

Code	Pressure Range
10	6.9 - 69 Bar (100 - 1000 PSI) Standard Setting: 34.5 Bar (500 PSI) @ crack pressure, approximately .95 LPM (.25 GPM)
20	6.9 - 138 Bar (100 - 2000 PSI) Standard Setting: 69 Bar (1000 PSI) @ crack pressure, approximately .95 LPM (.25 GPM)
30	13.8 - 207 Bar (200 - 3000 PSI) Standard Setting: 172.4 Bar (2500 PSI) @ crack pressure, approximately .95 LPM (.25 GPM)
50	13.8 - 345 Bar (200 - 5000 PSI) Standard Setting: 241.4 Bar (3500 PSI) @ crack pressure, approximately .95 LPM (.25 GPM)

Code	Cracking Pressure
Omit	0.3 Bar (5 PSI)
P15	1.0 Bar (15 PSI)
P20	1.4 Bar (20 PSI)
P40	2.8 Bar (40 PSI)
P50	3.5 Bar (50 PSI)
P65	4.5 Bar (65 PSI)
P80	5.5 Bar (80 PSI)

Code	Port Size	Part No.
8T	SAE-8	830349

Individual body requires 1 SAE 5 plug.
 Part number 5 HP50N-S.

- CV**
Check Valves
- SH**
Shuttle Valves
- LM**
Load/Motor Controls
- FC**
Flow Controls
- PC**
Pressure Controls
- LE**
Logic Elements
- DC**
Directional Controls
- MV**
Manual Valves
- SV**
Solenoid Valves
- PV**
Proportional Valves
- CE**
Coils & Electronics
- BC**
Bodies & Cavities
- TD**
Technical Data

	SERIES	CAVITY	DESCRIPTION	FLOW LPM/GPM	PRESSURE BAR/PSI	PAGE NO.
	PRESSURE RELIEVING					
	AP01B2YP	2G	Increase Pressure/Increase Current	5.3/1.4	350/5000	PV7-PV8
	AP02B2YP	C08-2	Increase Pressure/Increase Current	5.3/1.4	350/5000	PV9-PV10
	AP04G2YP	C10-2	Increase Pressure/Increase Current	45/12	350/5000	PV11-PV12
	PRESSURE RELIEVING					
	AP01B2YR	2G	Decrease Pressure/Increase Current	5.3/1.4	350/5000	PV13-PV14
	AP02B2YR	C08-2	Decrease Pressure/Increase Current	5.3/1.4	350/5000	PV15-PV16
	AP04G2YR	C10-2	Decrease Pressure/Increase Current	95/25	350/5000	PV17-PV18
	PRESSURE REDUCING					
	GP01 30	54-1	Pressure Reducing Valve	1.9/5	210/3000	PV19-PV20
	GTP02 34	C08-3	Pressure Reducing Valve	19/5	210/3000	PV21-PV22
	GTP04 34	3X	Pressure Reducing Valve	30/8	210/3000	PV23-PV24
	FLOW CONTROLS, 2-Way					
	DF122C	C12-2	Flow Control, N.C.	53/14	210/3000	PV25-PV26
	DF161C	C16-2	Flow Control, N.C.	150/40	210/3000	PV27-PV28
	DF201C	C20-2	Flow Control, N.C.	325/60	210/3000	PV29-PV30
	HP02C	2X	Flow Control, N.C.	23/6	210/3000	PV31-PV32
	JP02C	C08-3	Flow Control, N.C.	23/6	210/3000	PV33-PV34
	HP04C	C10-2	Flow Control, N.C.	36/9.5	210/3000	PV35-PV36
	JP04C 21	3X	Flow Control, N.C.	36/9.5	210/3000	PV37-PV38
	DFA125C21*	C12-3L	Flow Control, N.C.	56.8/15	210/3000	PV39-PV40
	<i>*The DFA125C21 will be available January 1, 2011.</i>					
	HP02P	2X	Flow Control, N.O.	19/5	210/3000	PV41-PV42
	JP02P	C08-3	Flow Control, N.O.	19/5	210/3000	PV43-PV44
	HP04P	C10-2	Flow Control, N.O.	30/8	210/3000	PV45-PV46
	JP04P	3X	Flow Control, N.O.	36/9.5	210/3000	PV47-PV48
	DF122N	C12-2	Flow Control, N.O.	53/14	210/3000	PV49-PV50
	FLOW CONTROLS, 3-WAY					
	JP04C 31	4C	Priority Flow Control, N.C.	30/8	210/3000	PV51-PV52
	DFA125C31	C12-4L	Priority Flow Control, N.C.	56.8/15	210/3000	PV53-PV54
	DIRECTIONAL CONTROL					
	GP02 51	C08-4	4 Way, 3 Pos - Closed Center	21/5.5	350/5000	PV55-PV56
	GP02 53	C08-4	4 Way, 3 Pos - Float Center	17/4.5	350/5000	PV57-PV58
	DSP105C1	C10-4	4 Way, 3 Pos - Closed Center	32/8.5	210/3000	PV59-PV61
	DSP105C4	C10-4	4 Way, 3 Pos - Float Center	32/8.5	210/3000	PV59-PV61

- CV**
Check Valves
- SH**
Shuttle Valves
- LM**
Load/Motor Controls
- FC**
Flow Controls
- PC**
Pressure Controls
- LE**
Logic Elements
- DC**
Directional Controls
- MV**
Manual Valves
- SV**
Solenoid Valves
- PV**
Proportional Valves
- CE**
Coils & Electronics
- BC**
Bodies & Cavities
- TD**
Technical Data

CV

Check
Valves

INTRODUCTION

This technical tips section is designed to help familiarize you with the Parker line of Proportional Valves. In this section we present common options, technical terms, as well as a brief synopsis of the operation and applications of the various products offered in this section. The intent of this section is to help you in selecting the best products for your application.

SH

Shuttle
Valves

LM

Load/Motor
Controls

COMMON OPTIONS

As you will see, Parker offers a variety of Proportional Valve products. As such, some of the options mentioned below may not be available on all valves. Consult the model coding and dimensions for each valve for specifics. Here are some of the common options available.

FC

Flow
Controls

Seals: The majority of the products are available in Nitrile or Fluorocarbon Seals. The Winner's Circle products feature a standard 4301 Polyurethane "D"-Ring. The "D"-Ring eliminates the need for backup rings. You should match the seal compatibility to the temperature and fluid being used in your application.

Overrides: Overrides are standard on many of the Parker proportional valves. The override is generally a push type that is flush with the end of the tube. Consult the individual catalog pages for more details.

PC

Pressure
Controls

LE

Logic
Elements

TECHNICAL TERMS

To help in applying our proportional valve line of product, we have listed some technical terms below, as well as some helpful hints in applying our valves.

DC

Directional
Controls

Ohm's Law: Electrical current is generated as a result of the relationship between input voltage and the resistance to the flow of electrical current. It is represented in equation form by $I = V/R$ (or $V=IR$), where I is current, V is voltage and R is resistance. This is an important relationship to remember when dealing with any electrically operated valves. Proportional valves allow varying control of flow or pressure, dependant on the current signal provided. As coils heat up, their resistance rises. This means a higher voltage must be available to maintain the same amount of pressure or flow. Thus, the application needs to be designed such that the full on position is about 70% of the initial current draw. On the individual catalog pages a maximum control current is specified to help in applying our proportional valves.

small back and forth movement of the valve spool around its set position. This rapid movement reduces the friction of the valve and leads to faster, more accurate response.

MV

Manual
Valves

SV

Solenoid
Valves

PV

Proportional
Valves

CE

Coils &
Electronics

PWM: Pulse Width Modulation (PWM) is the preferred signal for controlling electrical current. PWM is on / off voltage in a square wave form. The percent "on" time or duty cycle provides the average voltage. The valve driver adjusts the duty cycle to obtain current control. We recommend valve drivers with current control for optimum performance. PWM signals also usually provide dither for the proportional valve. Dither is a

PWM Frequency: The frequency of a PWM signal is the rate at which the signal is turned on and off. Parker's analog proportional valves are designed to work with low frequency responses between 100-400 Hz. The performance curves on our catalog pages were performed with a PWM signal at 200 Hz.

Hysteresis: Due to various factors, the performance of a proportional valve will show a slightly different performance when the current signal is increasing than it will when the signal is being decreased. This difference is usually expressed as a percentage of total input change and is referred to as the hysteresis of the valve.

BC

Bodies &
Cavities

TD

Technical
Data

Deadband: Cracking or deadband refers to the amount of the control signal that is needed to produce any movement of the spool. Thus, a 20% deadband means that 20% of the control signal is needed before the spool will move.

PRODUCT TYPES / APPLICATIONS

Proportional valves are nothing more than electrically adjustable hydraulic valves. They give the operator nearly infinite adjustment control and flexibility. Parker Hannifin offers various types of proportional flow control, pressure reducing, and relief valves.

Proportional Flow Control Valve

Proportional flow control valves provide pseudo pressure compensation and are used on systems requiring variable electronic control of flow. They allow the operator to vary the control signal to accelerate or decelerate an actuator. A compensator valve can be added to the circuit for enhanced compensation. Some typical applications would include the hoist control for a lift, or the speed control for a winch circuit. Parker offers both normally closed and normally open versions of proportional flow controls.

Normally Closed Proportional Flow Control

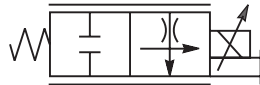

OPERATION - With the solenoid coil de-energized, the spool is held in a closed position by the spring force. When the solenoid coil is energized, the amperage of the signal moves the spool into an open position.

The spool is held in this position by a balance between spring force and electrical force. As the current increases, the spools opens further; allowing more flow. As the current decreases, the spool begins closing; allowing less flow. Pseudo compensation is obtained by the pressure drop across the orifices in the spool.

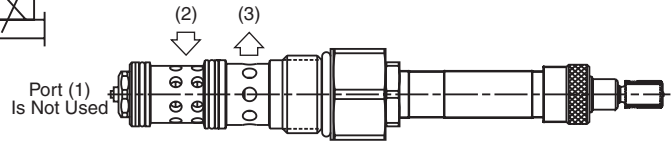

Normally Open Proportional Flow Control

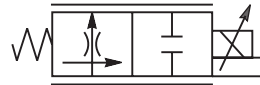

OPERATION - With the solenoid coil de-energized, the spool is held in an open position by spring force; allowing full flow to pass. As the solenoid coil is energized, the spool begins to move away from a full open position; allowing less flow to pass. Once a full electronic signal is given, the spool is held in a closed position; allowing no flow to pass. As the electronic signal is then reduced, the spool begins to open; allowing flow to pass again. Once a constant electronic signal is given, the spool is held in that position by a balance between electronic force and spring force. Pseudo compensation is obtained by the pressure drop across the orifices in the spool.

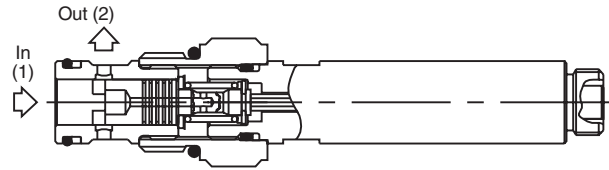

Normally Closed Proportional Needle Valve

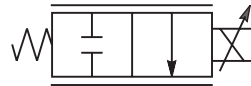

The proportional needle valves are electronic controlled variable needle valves. They are designed specifically for bleed off or unloading circuits as back pressure will affect performance.

OPERATION - With the solenoid de-energized, the main poppet is held in the closed position by spring force. When the solenoid is energized, the sensing spool moves into a partially open position relative to the percentage of rated current flowing through the coil. This action allows the main poppet to move away from the valve seat to a degree that corresponds to sensing spool position. The valve will maintain a fixed amount of opening as long as the electrical current remains constant and will vary proportionally with an increase or decrease in current.

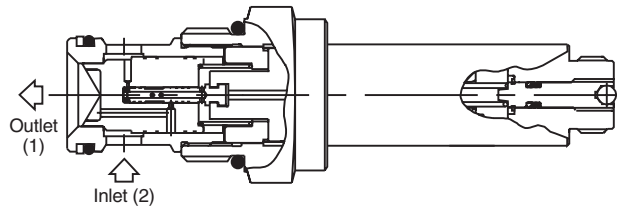

CV

Check Valves

SH

Shuttle Valves

LM

Load/Motor Controls

FC

Flow Controls

PC

Pressure Controls

LE

Logic Elements

DC

Directional Controls

MV

Manual Valves

SV

Solenoid Valves

PV

Proportional Valves

Coils & Electronics

BC

Bodies & Cavities

TD

Technical Data

- CV** Check Valves
- SH** Shuttle Valves
- LM** Load/Motor Controls
- FC** Flow Controls
- PC** Pressure Controls
- LE** Logic Elements
- DC** Directional Controls
- MV** Manual Valves
- SV** Solenoid Valves
- PV** Proportional Valves
- CE** Coils & Electronics
- BC** Bodies & Cavities
- TD** Technical Data

Proportional Priority Bypass Flow Control

The proportional priority bypass flow controls allow electronic control of the flow setting for the priority flow circuit. The priority flow remains constant regardless of changes in load or pressure. The excess inlet flow is diverted or bypassed to tank. The bypass port must not have any restrictions or performance will be hindered.

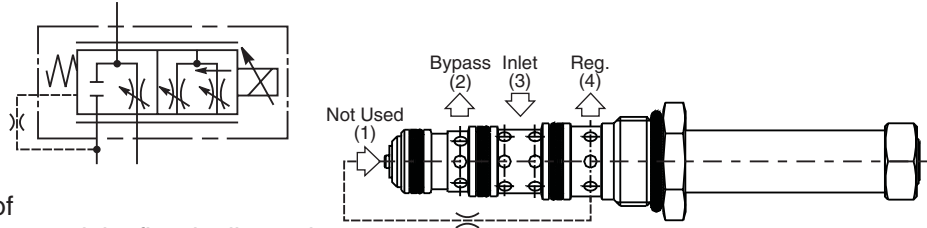

OPERATION - Flow enters the valve through port 3. With the coil de-energized, flow is bypassed to port 2. When the coil is energized, the internal orifice is increased allowing pressure compensated flow to the priority port (port 4). The excess flow is bypassed to port 2. As input current is increased, the priority flow increases and the bypass flow decreases. As the current is decreased, priority flow decreases and bypass flow is increased.

Direct Acting, Normally Closed Proportional Pressure Reducing Valve

Direct acting, normally closed proportional pressure reducing valves are used to electronically reduce the inlet pressure to one leg of a hydraulic circuit. This valve is used when a fixed regulated pressure is required regardless of the inlet pressure. This valve could be used as a clutch control for power shift transmissions and PTO, or as a pilot control for directional control valves.

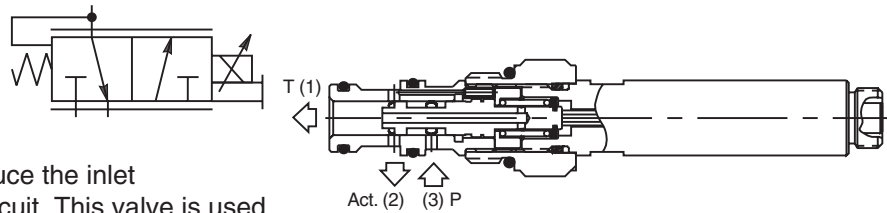

OPERATION - With the solenoid coil de-energized, the spool is held in a closed position by spring force. In this mode, the regulated pressure port is open to tank and the pressure inlet is blocked. As current is applied to the solenoid coil, the spool will begin to travel to a position where the pressure inlet port is connected to the regulated pressure port. At this point, reduced pressure becomes a function of the current signal. As long as the current signal is constant, the reduced pressure at the regulated pressure port will remain fixed regardless of any changes in inlet flow or inlet pressure. As the current signal increases or decreases, the reduced pressure at the regulated pressure port will change with respect to the changes in signal. Once the coil is fully energized, the reduced pressure of the regulated pressure port will be at the maximum reduced pressure for that valve.

Normally Closed Proportional Pressure Reducing / Relieving Valve

Normally Closed Proportional Pressure Reducing/Relieving Valves are used to electronically reduce the inlet pressure to one leg of a hydraulic circuit. In addition these valves act as a relief valve, relieving any shocks or surges that occur between its regulating port and the actuator. Parker offers direct acting and pilot operated versions of this valve. The direct acting valves are faster responding and generally have lower hysteresis, but are limited to smaller reduced pressures (generally below 800 psi depending on the valve.) Pilot operated are generally slower on response due to the two stage performance, but can have a reduced pressure as high as 3000 psi.

Direct Acting

OPERATION - With the solenoid coil de-energized, the spool is held in a closed position by spring force.

In this mode, the regulated pressure port is open to tank and the pressure inlet port is blocked. As an electronic signal is applied to the solenoid coil, the spool will begin to travel to a position where the pressure inlet port is connected to the regulated pressure port. At this point, reduced pressure becomes a function of the voltage signal. As long as the electronic signal is constant, the reduced pressure at the regulated pressure port will remain fixed regardless of any changes in inlet flow or inlet pressure. As the electronic signal increases or decreases, the reduced pressure at the regulated port will change with respect to the change in electronic signal. Once a full signal is given, the reduced pressure of the regulated pressure port will be at the maximum reduced pressure for that valve.

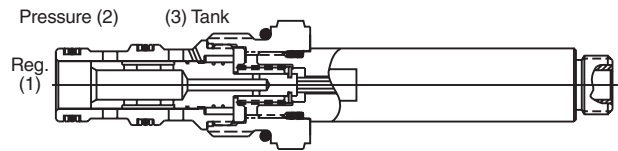
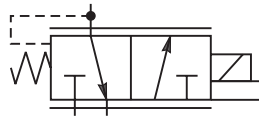

Pilot Operated

OPERATION - With the solenoid coil de-energized, the pilot dart is held open by the spring force. This allows the main spool to close and restricts flow from going from the inlet (2) port to the regulated port (1).

As the electronic signal is applied to the coil, the pilot dart is moved towards the pilot seat restricting pilot flow. This restriction raises the effective pressure inside the chamber between the spool and the pilot seat, allowing the spool to travel away from the pilot seat to a position where the pressure at inlet (2) is connected to the regulated pressure port (1). At this point, reduced pressure becomes a function of the electronic signal. As long as the electronic signal is constant, the reduced pressure at the regulated pressure port (2) will remain fixed regardless of any changes in inlet flow or inlet pressure. As the electronic signal increases or decreases, the reduced pressure at port (1) will change with respect to the change in the electronic signal.

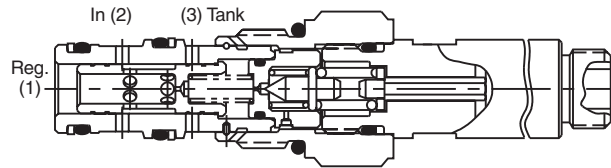
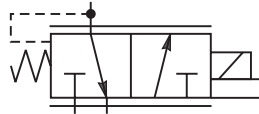

CV

Check Valves

SH

Shuttle Valves

LM

Load/Motor Controls

FC

Flow Controls

PC

Pressure Controls

LE

Logic Elements

DC

Directional Controls

MV

Manual Valves

SV

Solenoid Valves

PV

Proportional Valves

CE

Coils & Electronics

BC

Bodies & Cavities

TD

Technical Data

CV	Check Valves
SH	Shuttle Valves
LM	Load/Motor Controls
FC	Flow Controls
PC	Pressure Controls
LE	Logic Elements
DC	Directional Controls
MV	Manual Valves
SV	Solenoid Valves
PV	Proportional Valves
CE	Coils & Electronics
BC	Bodies & Cavities
TD	Technical Data

Normally Closed Proportional Relief Valve

Normally closed proportional relief valves are used to electronically control the system pressure. These valves are ideal for circuits with varying system pressures demands. A small flow pilot version of the normally closed proportional relief is also offered for piloting a larger logic element or vented relief valve. The normally closed relief defaults to a maximum pressure setting (i.e. 3000 psi) when there is no current applied.

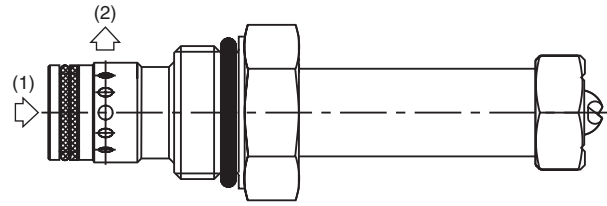
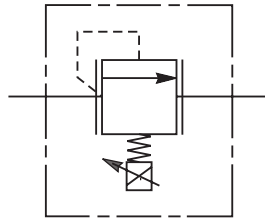

OPERATION - With the solenoid coil de-energized, the pilot dart is held closed by the spring. As current is applied to the coil, the pilot dart is moved creating less restriction of the pilot flow. As this restriction is reduced with the increasing current, the pressure setting also decreases. Once a constant electronic signal is given, the pilot dart is held in a given position, holding the pressure setting. This is maintained by the balance between the electronic spring force and the inlet pressure.

Normally Open Proportional Relief Valve

Normally open proportional relief valves are used to electronically control the system pressure. These valves are ideal for circuits with varying system pressure demands. A small flow pilot version of the normally open proportional relief is also offered for piloting a larger logic element or vented relief valve. The normally open relief defaults to minimum system pressure (i.e. 150 psi) when there is no current applied. Normally closed versions are also available upon request.

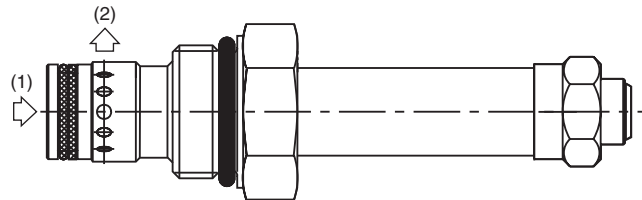
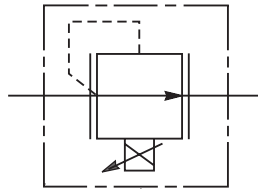

OPERATION - With the solenoid coil de-energized, the pilot dart is held open by the spring. This allows the main spool to open at minimum pressure 10.4 Bar (150 psi). As current is applied to the coil, the pilot dart is moved towards the pilot seat restricting pilot flow. This restriction raises the effective pressure setting of the valve. Once a constant electronic signal is given, the pilot dart is held in a given position, holding the pressure setting. This is maintained by a balance between electronic spring force and inlet pressure. As the electronic signal is reduced, the pilot dart is moved away from the pilot seat. This lowers the effective pressure setting of the valve.

Technical Information

- CV** Check Valves
- SH** Shuttle Valves
- LM** Load/Motor Controls
- FC** Flow Controls
- PC** Pressure Controls
- LE** Logic Elements
- DC** Directional Controls
- MV** Manual Valves
- SV** Solenoid Valves
- PV** Proportional Valves
- CE** Coils & Electronics
- BC** Bodies & Cavities
- TD** Technical Data

General Description

Proportional Relief Valve. Increasing Pressure With Increasing Current. For additional information see Technical Tips on pages PV1-PV6.

Features

- Analog Proportional Relief Valve regulates pressure proportionally to the solenoid current
- Direct acting poppet design
- One piece cartridge housing ensures internal concentricity
- Coil: Waterproof, hermetically sealed, requires no O'Rings; Symmetrical coil can be reversed without affecting performance.

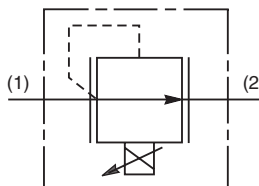
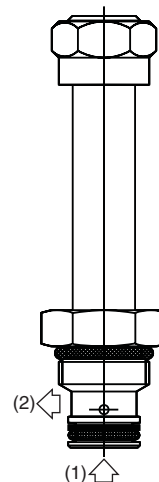

Specifications

Rated Flow (At 70 PSI ΔP)	07C 5.3 LPM (1.4 GPM) 14C 3.4 LPM (0.9 GPM) 21C 3.0 LPM (0.8 GPM) 35C 1.3 LPM (.35 GPM)
Max. Pressure At Port 1 @ 75% Input Current	07C 70 Bar (1000 PSI) 14C 140 Bar (2000 PSI) 21C 210 Bar (3000 PSI) 35C 350 Bar (5000 PSI)
Hysteresis @ 200 Hz PWM	5%
Cracking Pressure	07C .07 Bar (1 PSI) 14C .14 Bar (2 PSI) 21C .21 Bar (3 PSI) 35C .35 Bar (4 PSI)
Cartridge Material	All parts steel. All operating parts hardened steel.
Operating Temp. Range/Seals	-40°C to +93.3°C (Nitrile) (-40°F to +200°F) -31.7°C to +121.1°C (Fluorocarbon) (-25°F to +250°F)
Fluid Compatibility/ Viscosity	Mineral-based or synthetic with lubricating properties at viscosities of 45 to 2000 SSU (6 to 420 cSt)
Filtration	ISO Code 16/13, SAE Class 4 or better
Approx. Weight	.06 kg (.14 lbs.)
Cavity	2G (See BC Section for more details)

Performance Curves

▲ PWM Current Regulator Recommended

Pressure Drop vs. Flow

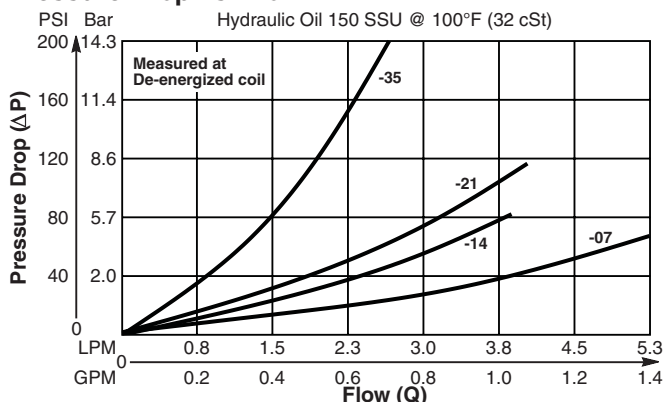

Pressure vs. Input Signal (Current)

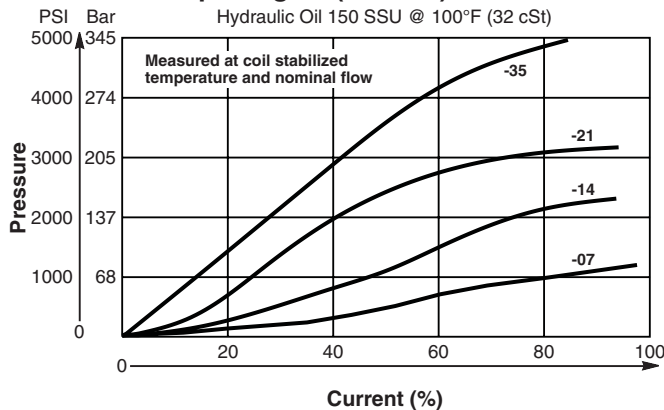

Dimensions Millimeters (Inches)

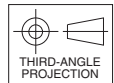
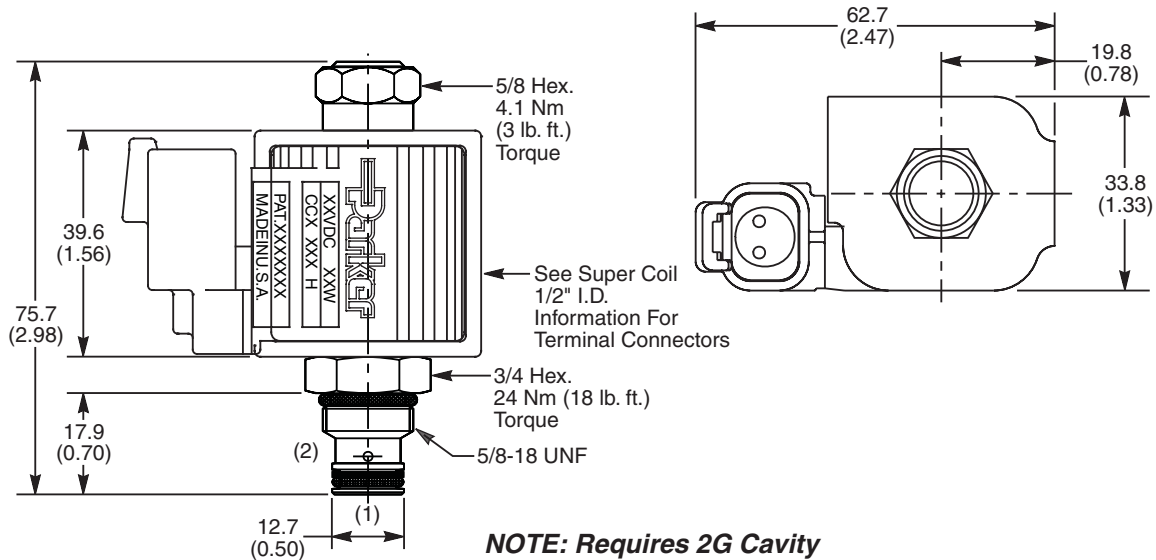

Ordering Information

AP01B2YP

08 Size Proportional Relief Valve Style Seals Coil Type Coil Voltage Coil Termination

Code	Style (Maximum Relief Pressure)
07C	70 Bar (1000 PSI)
14C	140 Bar (2000 PSI)
21C	210 Bar (3000 PSI)
35C	350 Bar (5000 PSI)

Custom pressure setting available. Consult factory.

Code	Seals / Kit No.
N	Nitrile / Buna-N (Std.) (SK30129N-1)
V	Fluorocarbon / (SK30129V-1)
E	Ethylene Propylene

Code	Coil Type
Omit	Without Coil
SP	Super Coil - 19 Watts

Code	Coil Voltage
Omit	Without Coil
D012	12 VDC
D024	24 VDC

Code	Coil Termination
Omit	Without Coil
D	DIN Plug Face
A	Amp Jr. Timer*
L	Dual Lead Wire*
LS	Sealed Lead Wire*
H	Molded Deutsch*

See Super Coil 1/2" I.D. *DC Only

Order Bodies Separately

LB10

Line Body Porting Body Material

Code	Porting
324	1/4" SAE
325	1/4" BSP

Code	Body Material
A	Aluminum
S	Steel



- CV** Check Valves
- SH** Shuttle Valves
- LM** Load/Motor Controls
- FC** Flow Controls
- PC** Pressure Controls
- LE** Logic Elements
- DC** Directional Controls
- MV** Manual Valves
- SV** Solenoid Valves
- PV** Proportional Valves
- CE** Coils & Electronics
- BC** Bodies & Cavities
- TD** Technical Data

Technical Information

- CV** Check Valves
- SH** Shuttle Valves
- LM** Load/Motor Controls
- FC** Flow Controls
- PC** Pressure Controls
- LE** Logic Elements
- DC** Directional Controls
- MV** Manual Valves
- SV** Solenoid Valves
- PV** Proportional Valves
- CE** Coils & Electronics
- BC** Bodies & Cavities
- TD** Technical Data

General Description

Proportional Relief Valve. Increasing Pressure With Increasing Current. For additional information see Technical Tips on pages PV1-PV6.

Features

- Analog Proportional Relief Valve regulates pressure proportionally to the solenoid current
- Direct acting poppet design
- One piece cartridge housing ensures internal concentricity
- Coil: Waterproof, hermetically sealed, requires no O'Rings; Symmetrical coil can be reversed without affecting performance.

NOTE:

This valve will be available January 1, 2011.

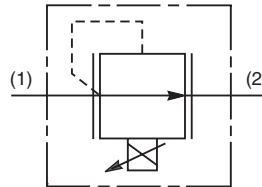
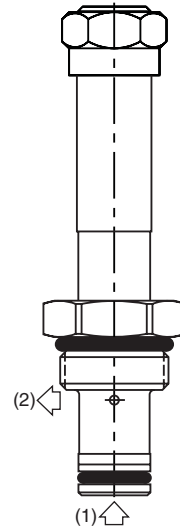
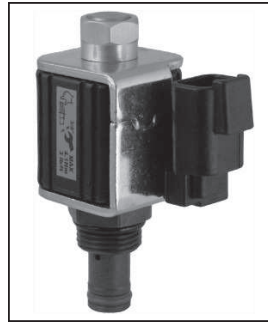

Specifications

Rated Flow (At 70 PSI ΔP)	07C 5.3 LPM (1.4 GPM) 14C 3.4 LPM (0.9 GPM) 21C 3.0 LPM (0.8 GPM) 35C 1.3 LPM (.35 GPM)
Max. Pressure At Port 1 @ 75% Input Current	07C 70 Bar (1000 PSI) 14C 140 Bar (2000 PSI) 21C 210 Bar (3000 PSI) 35C 350 Bar (5000 PSI)
Hysteresis @ 200 Hz PWM	5%
Cracking Pressure	07C .07 Bar (1 PSI) 14C .14 Bar (2 PSI) 21C .21 Bar (3 PSI) 35C .35 Bar (4 PSI)
Cartridge Material	All parts steel. All operating parts hardened steel.
Operating Temp. Range/Seals	-40°C to +93.3°C (Nitrile) (-40°F to +200°F) -31.7°C to +121.1°C (Fluorocarbon) (-25°F to +250°F)
Fluid Compatibility/ Viscosity	Mineral-based or synthetic with lubricating properties at viscosities of 45 to 2000 SSU (6 to 420 cSt)
Filtration	ISO Code 16/13, SAE Class 4 or better
Approx. Weight	.06 kg (.14 lbs.)
Cavity	C08-2 (See BC Section for more details)

Performance Curves

▲ PWM Current Regulator Recommended

Pressure Drop vs. Flow

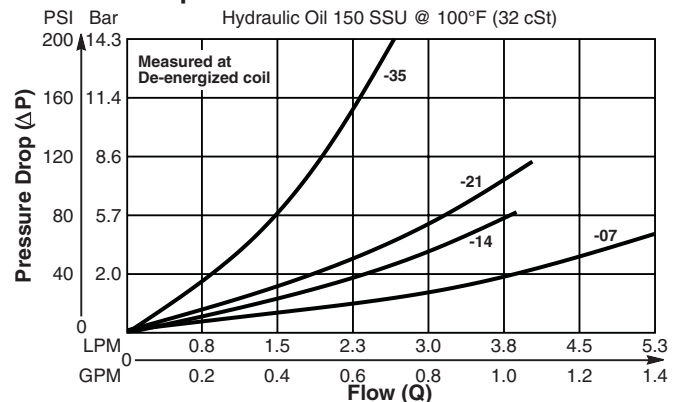

Pressure vs. Input Signal (Current)

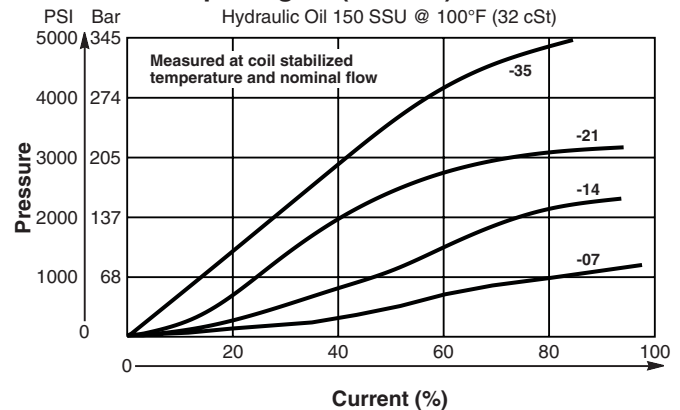

Dimensions Millimeters (Inches)

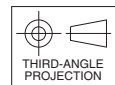
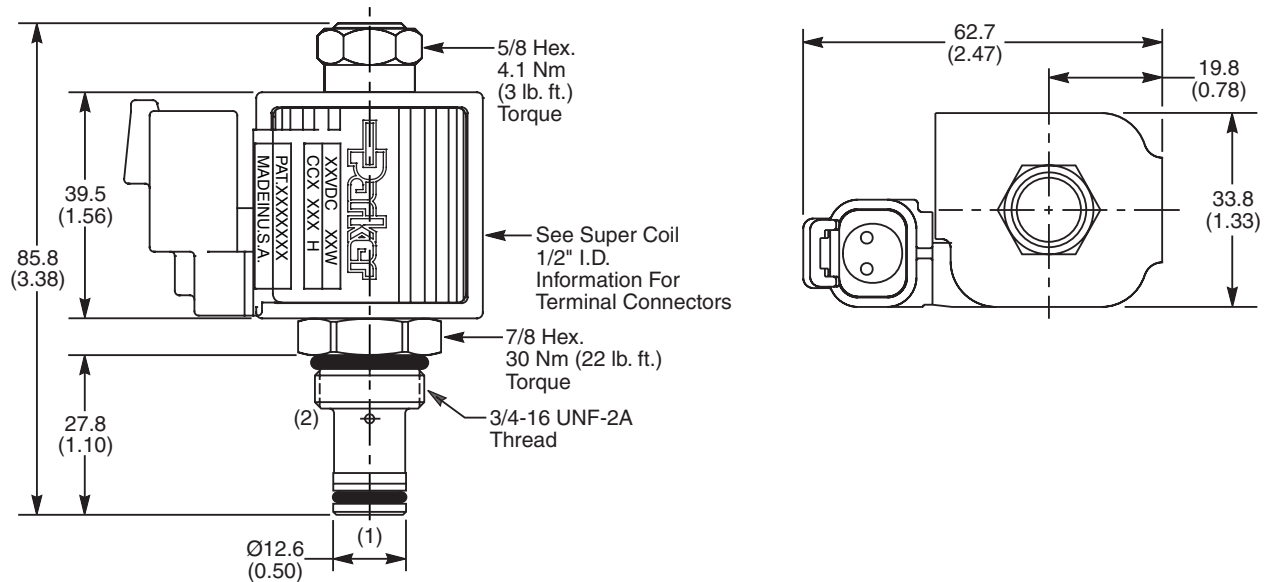

Ordering Information

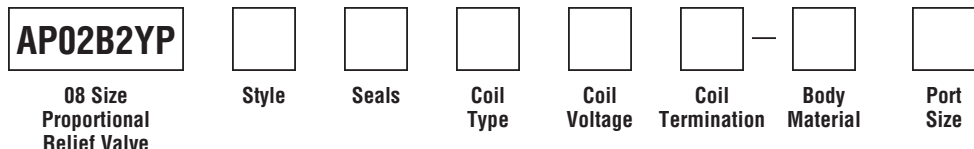

NOTE:
*This valve will be available
 January 1, 2011.*

Code	Style (Maximum Relief Pressure)
07C	70 Bar (1000 PSI)
14C	140 Bar (2000 PSI)
21C	210 Bar (3000 PSI)
35C	350 Bar (5000 PSI)

*Custom pressure setting available.
 Consult factory.*

Code	Seals / Kit No.
Omit	"D"-Ring / (SK08-2)
N	Nitrile / Buna-N (Std.) (SK08-2N)
V	Fluorocarbon / (SK08-2V)

Code	Coil Type
Omit	Without Coil
SP	Super Coil - 19 Watts

Code	Coil Voltage
Omit	Without Coil
D012	12 VDC
D024	24 VDC

Code	Coil Termination
Omit	Without Coil
D	DIN Plug Face
A	Amp Jr. Timer*
L	Dual Lead Wire*
LS	Sealed Lead Wire*
H	Molded Deutsch*

*See Super Coil 1/2" I.D.
 DC Only

Code	Body Material
Omit	Steel
A	Aluminum

Code	Port Size	Body Part No.
Omit	Cartridge Only	
4T	SAE-4	(B08-2-*4T)
6T	SAE-6	(B08-2-*6T)
6B	3/8" BSPG	(B08-2-*6B)

** Add "A" for aluminum, omit for steel.*



- CV**
Check Valves
- SH**
Shuttle Valves
- LM**
Load/Motor Controls
- FC**
Flow Controls
- PC**
Pressure Controls
- LE**
Logic Elements
- DC**
Directional Controls
- MV**
Manual Valves
- SV**
Solenoid Valves
- PV**
Proportional Valves
- CE**
Coils & Electronics
- BC**
Bodies & Cavities
- TD**
Technical Data

Technical Information

- CV** Check Valves
- SH** Shuttle Valves
- LM** Load/Motor Controls
- FC** Flow Controls
- PC** Pressure Controls
- LE** Logic Elements
- DC** Directional Controls
- MV** Manual Valves
- SV** Solenoid Valves
- PV** Proportional Valves
- CE** Coils & Electronics
- BC** Bodies & Cavities
- TD** Technical Data

General Description

Proportional Relief Valve. Increasing Pressure With Increasing Current. For additional information see Technical Tips on pages PV1-PV6.

Features

- Pilot operated spool-type design fits industry common cavity (10-2)
- Relieving pressure output is proportional to DC current input
- Precise setting of factory preset pressure in energized mode
- One piece cartridge housing ensures internal concentricity
- Coil: Waterproof, hermetically sealed, requires no O’Rings; Symmetrical coil can be reversed without affecting performance.

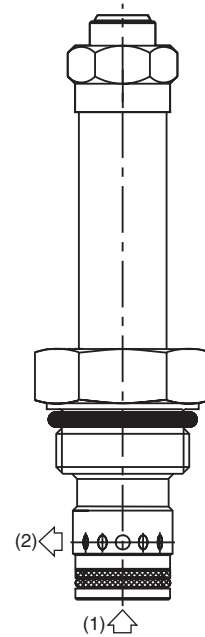
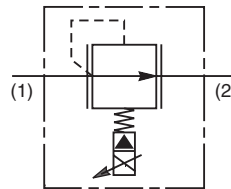
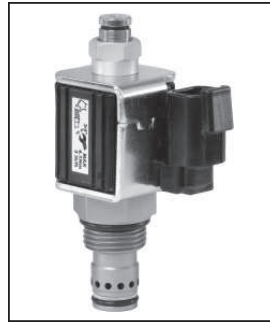

Specifications

Rated Flow (At 300 PSI ΔP) When Coil is Fully De-Energized	95 LPM (25 GPM)	
Factory Set Relief Pressure When Coil De-Energized Measured at 45 LPM (12 GPM)	10C	103 Bar (1500 PSI)
	21C	210 Bar (3000 PSI)
	35C	350 Bar (5000 PSI)
Hysteresis @ 250 Hz PWM	< 7% of Maximum Pressure Setting	
Response Time At 75% of Nominal Voltage Change (Measured To 90% of Press. Change)	To Unload	10ms
	To Load	
	10C	45 ms
	21C	60 ms
	35C	80 ms
Cartridge Material	All parts steel. All operating parts hardened steel.	
Operating Temp. Range/Seals	-40°C to +93.3°C (Nitrile) (-40°F to +200°F)	
	-31.7°C to +121.1°C (Fluorocarbon) (-25°F to +250°F)	
Fluid Compatibility/ Viscosity	Mineral-based or synthetic with lubricating properties at viscosities of 45 to 2000 SSU (6 to 420 cSt)	
Filtration	ISO Code 16/13, SAE Class 4 or better	
Approx. Weight	.14 kg (.31 lbs.)	
Cavity	C10-2 (See BC Section for more details)	

Performance Curves

▲ PWM Current Regulator Recommended

Relief Performance

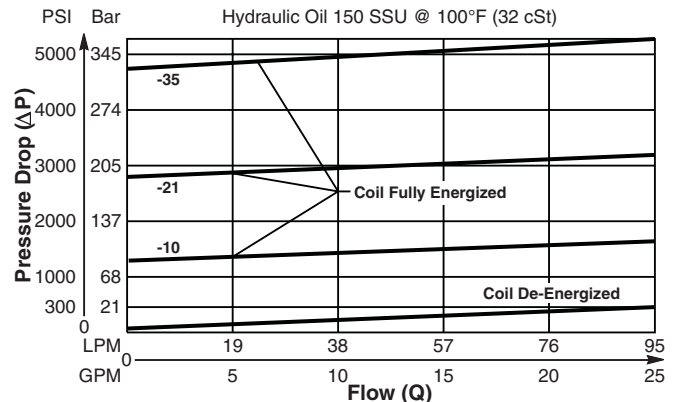

Pressure vs. Input Current

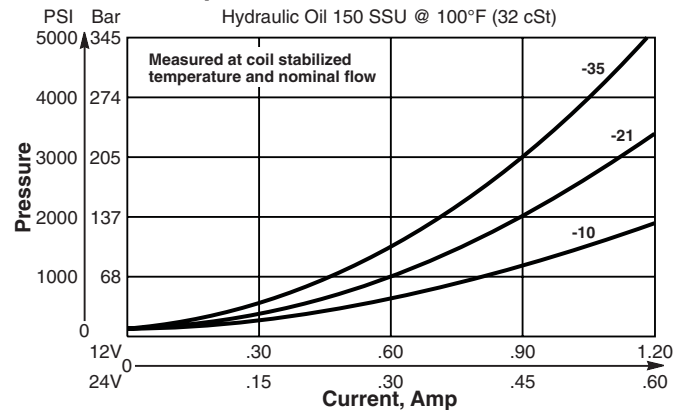

Dimensions Millimeters (Inches)

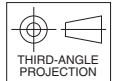
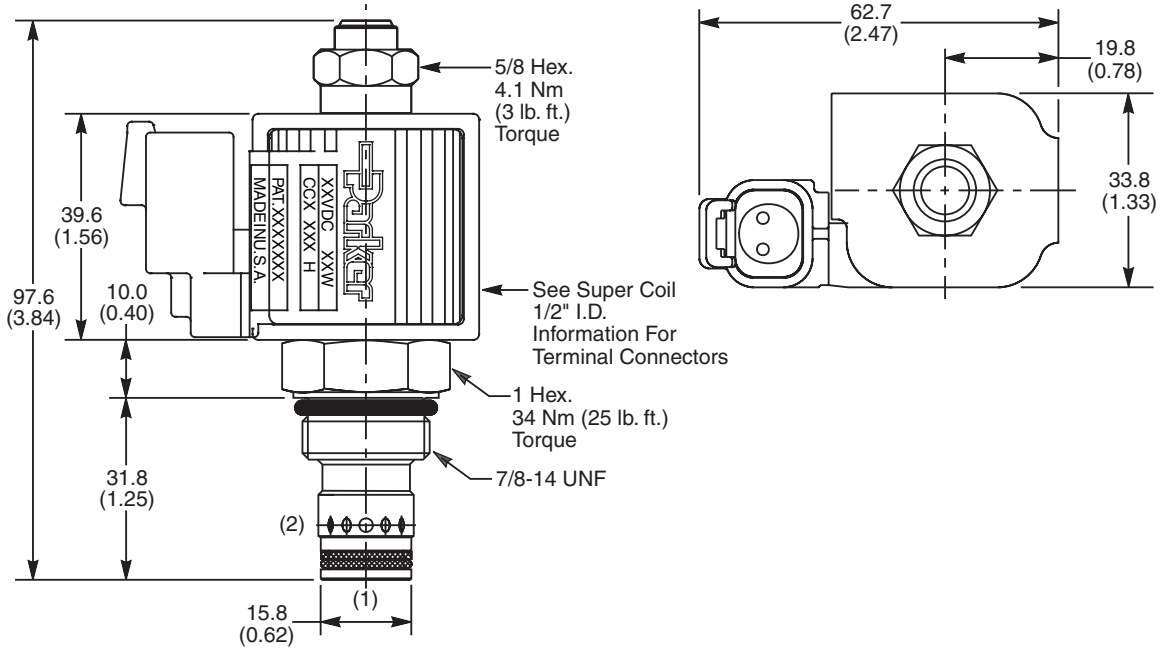

Ordering Information

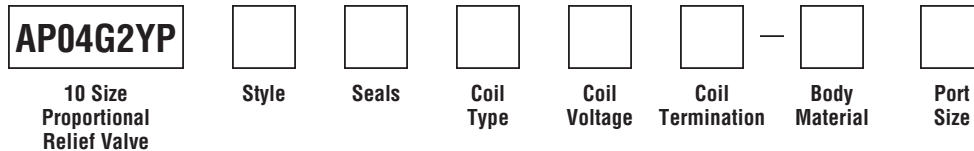

Code	Style (Maximum Relief Pressure)
10C	104 Bar (1500 PSI)
21C	210 Bar (3000 PSI)
35C	350 Bar (5000 PSI)

Custom pressure setting available. Consult factory.

Code	Seals / Kit. No.
N	Nitrile / Buna-N (Std.) (SK30503N-1)
V	Fluorocarbon / (SK30503V-1)

Code	Coil Type
Omit	Without Coil
SP	Super Coil - 19 Watts

Code	Coil Voltage
Omit	Without Coil
D012	12 VDC
D024	24 VDC

Code	Coil Termination
Omit	Without Coil
D	DIN Plug Face
A	Amp Jr. Timer*
L	Dual Lead Wire*
LS	Sealed Lead Wire*
H	Molded Deutsch*

See Super Coil 1/2" I.D.
 *DC Only

Code	Body Material
Omit	Steel
A	Aluminum

Code	Port Size	Body Part No.
Omit	Cartridge Only	
4P	1/4" NPTF	(B10-2-*4P)
6P	3/8" NPTF	(B10-2-*6P)
8P	1/2" NPTF	(B10-2-*8P)
6T	SAE-6	(B10-2-*6T)
8T	SAE-8	(B10-2-*8T)
T8T	SAE-8	(B10-2-T8T)†
6B	3/8" BSPG	(B10-2-*6B)

* Add "A" for aluminum, omit for steel.
 † Steel body only.

- CV
- Check Valves
- SH
- Shuttle Valves
- LM
- Load/Motor Controls
- FC
- Flow Controls
- PC
- Pressure Controls
- LE
- Logic Elements
- DC
- Directional Controls
- MV
- Manual Valves
- SV
- Solenoid Valves
- PV
- Proportional Valves
- CE
- Coils & Electronics
- BC
- Bodies & Cavities
- TD
- Technical Data

Technical Information

- CV** Check Valves
- SH** Shuttle Valves
- LM** Load/Motor Controls
- FC** Flow Controls
- PC** Pressure Controls
- LE** Logic Elements
- DC** Directional Controls
- MV** Manual Valves
- SV** Solenoid Valves
- PV** Proportional Valves
- CE** Coils & Electronics
- BC** Bodies & Cavities
- TD** Technical Data

General Description

Proportional Relief Valve. Decreasing Pressure With Increasing Current. For additional information see Technical Tips on pages PV1-PV6.

Features

- Analog Proportional Relief Valve regulates pressure proportionally to the input solenoid current
- Direct acting poppet design
- One piece cartridge housing ensures internal concentricity
- Coil: Waterproof, hermetically sealed, requires no O’Rings; Symmetrical coil can be reversed without affecting performance.

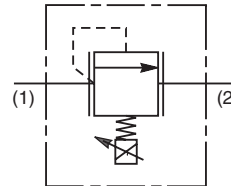
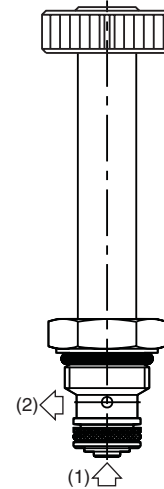

Specifications

Rated Flow (At 70 PSI ΔP)	07A 5.3 LPM (1.4 GPM) 14A 3.4 LPM (0.9 GPM) 21A 3.0 LPM (0.8 GPM) 35A 1.9 LPM (0.5 GPM)
Factory Set Relief Pressure When De-Energized (±5% -Std. ±2% - Low Variation)	07A 70 Bar (1000 PSI) 14A 140 Bar (2000 PSI) 21A 210 Bar (3000 PSI) 35A 350 Bar (5000 PSI)
Hysteresis @ 200 Hz PWM	< 10%
Cartridge Material	All parts steel. All operating parts hardened steel.
Operating Temp. Range/Seals	-40°C to +93.3°C (Nitrile) (-40°F to +200°F) -31.7°C to +121.1°C (Fluorocarbon) (-25°F to +250°F)
Fluid Compatibility/ Viscosity	Mineral-based or synthetic with lubricating properties at viscosities of 45 to 2000 SSU (6 to 420 cSt)
Filtration	ISO Code 16/13, SAE Class 4 or better
Approx. Weight	.09 kg (.19 lbs.)
Cavity	2G (See BC Section for more details)

Performance Curves

▲ PWM Current Regulator Recommended

Relief Performance

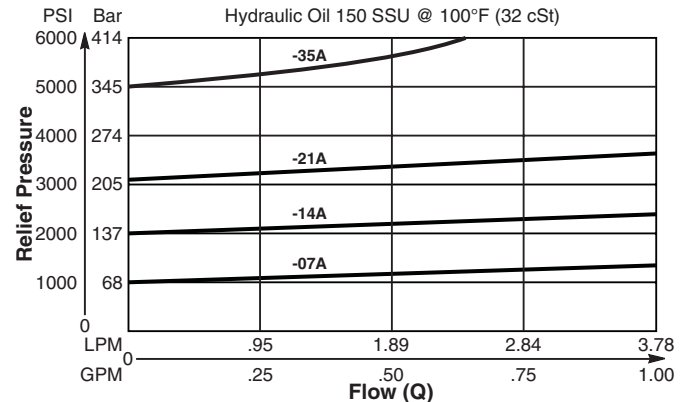

Pressure vs. Input Current

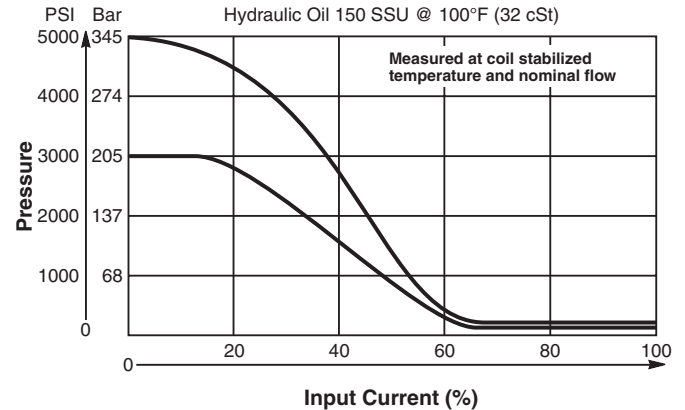

Dimensions Millimeters (Inches)

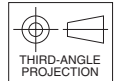
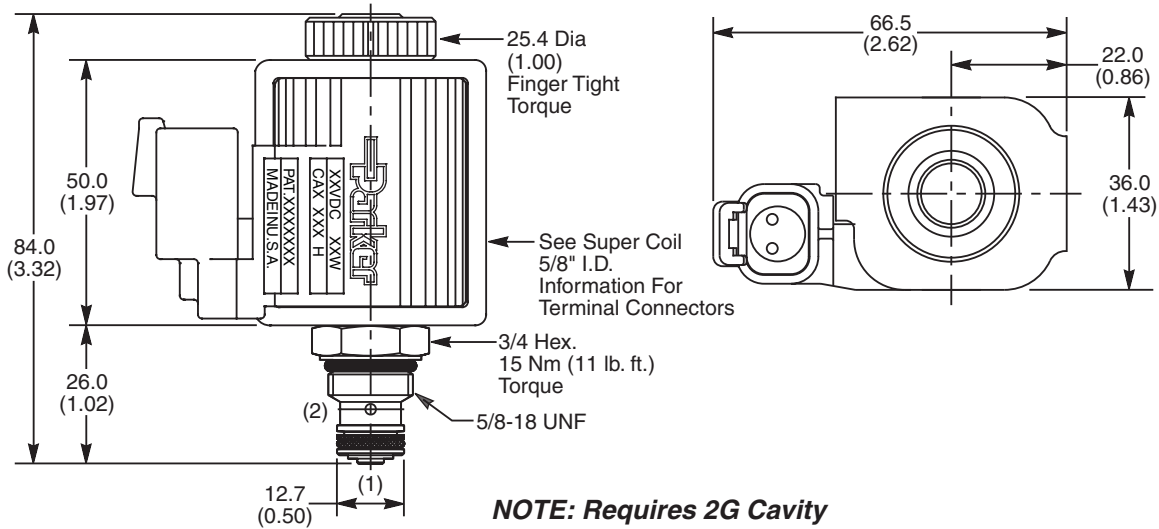

Ordering Information

AP01B2YR

08 Size Proportional Relief Valve Style Seals Coil Type Coil Voltage Coil Termination

Code	Style (Maximum Relief Pressure)
07AL	70 Bar (1000 PSI)
14AL	140 Bar (2000 PSI)
21AL	210 Bar (3000 PSI)
35AL	350 Bar (5000 PSI)

Custom pressure setting available. Consult factory.

Code	Seals / Kit. No.
N	Nitrile / Buna-N (Std.) (SK30129N-1)
V	Fluorocarbon / (SK30129V-1)
E	Ethylene Propylene

Code	Coil Type
Omit	Without Coil
SP	Super Coil - 28 Watts

Code	Coil Voltage
Omit	Without Coil
D012	12 VDC
D024	24 VDC

Code	Coil Termination
Omit	Without Coil
D	DIN Plug Face
A	Amp Jr. Timer*
L	Dual Lead Wire*
LS	Sealed Lead Wire*
H	Molded Deutsch*

See Super Coil 5/8" I.D.
 *DC Only

Order Bodies Separately

LB10

Line Body Porting Body Material

Code	Porting
324	1/4" SAE
325	1/4" BSP

Code	Body Material
A	Aluminum
S	Steel



- CV** Check Valves
- SH** Shuttle Valves
- LM** Load/Motor Controls
- FC** Flow Controls
- PC** Pressure Controls
- LE** Logic Elements
- DC** Directional Controls
- MV** Manual Valves
- SV** Solenoid Valves
- PV** Proportional Valves
- CE** Coils & Electronics
- BC** Bodies & Cavities
- TD** Technical Data

Technical Information

- CV** Check Valves
- SH** Shuttle Valves
- LM** Load/Motor Controls
- FC** Flow Controls
- PC** Pressure Controls
- LE** Logic Elements
- DC** Directional Controls
- MV** Manual Valves
- SV** Solenoid Valves
- PV** Proportional Valves
- CE** Coils & Electronics
- BC** Bodies & Cavities
- TD** Technical Data

General Description

Proportional Relief Valve. Decreasing Pressure With Increasing Current. For additional information see Technical Tips on pages PV1-PV6.

Features

- Analog Proportional Relief Valve regulates pressure proportionally to the input solenoid current
- Direct acting poppet design
- One piece cartridge housing ensures internal concentricity
- Coil: Waterproof, hermetically sealed, requires no O’Rings; Symmetrical coil can be reversed without affecting performance.

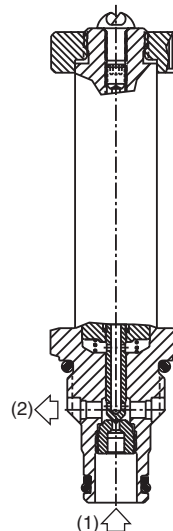
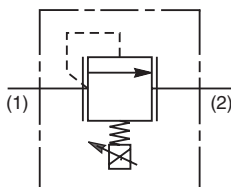

Specifications

Rated Flow (At 70 PSI ΔP)	07A 5.3 LPM (1.4 GPM) 14A 3.4 LPM (0.9 GPM) 21A 3.0 LPM (0.8 GPM) 35A 1.9 LPM (0.5 GPM)
Factory Set Relief Pressure When De-Energized (±5% -Std. ±2% - Low Variation)	07A 70 Bar (1000 PSI) 14A 140 Bar (2000 PSI) 21A 210 Bar (3000 PSI) 35A 350 Bar (5000 PSI)
Hysteresis @ 200 Hz PWM	< 10%
Cartridge Material	All parts steel. All operating parts hardened steel.
Operating Temp. Range/Seals	-40°C to +93.3°C (Nitrile) (-40°F to +200°F) -31.7°C to +121.1°C (Fluorocarbon) (-25°F to +250°F)
Fluid Compatibility/ Viscosity	Mineral-based or synthetic with lubricating properties at viscosities of 45 to 2000 SSU (6 to 420 cSt)
Filtration	ISO Code 16/13, SAE Class 4 or better
Approx. Weight	.09 kg (.19 lbs.)
Cavity	C08-2 (See BC Section for more details)

Performance Curves

▲ PWM Current Regulator Recommended

Relief Performance

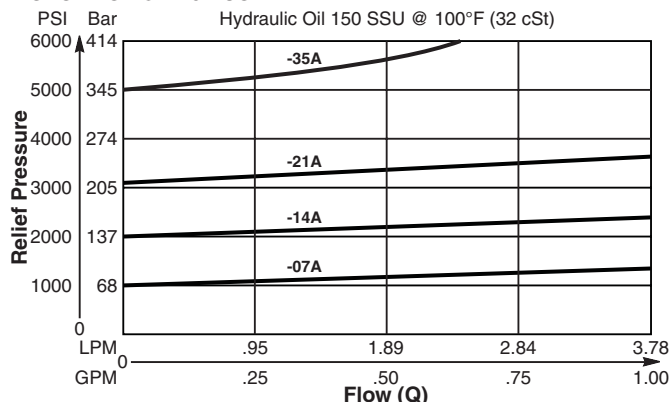

Pressure vs. Input Current

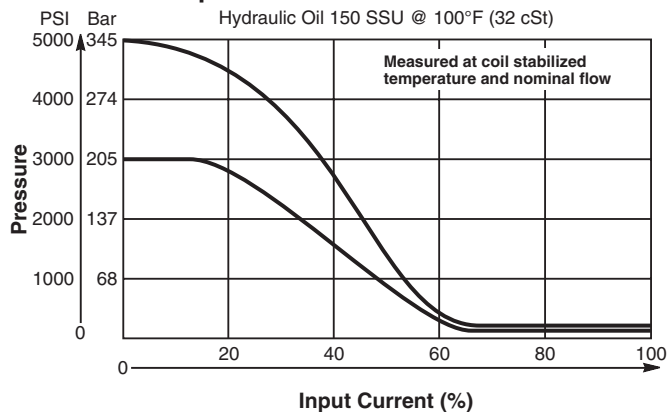

Dimensions Millimeters (Inches)

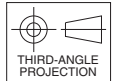
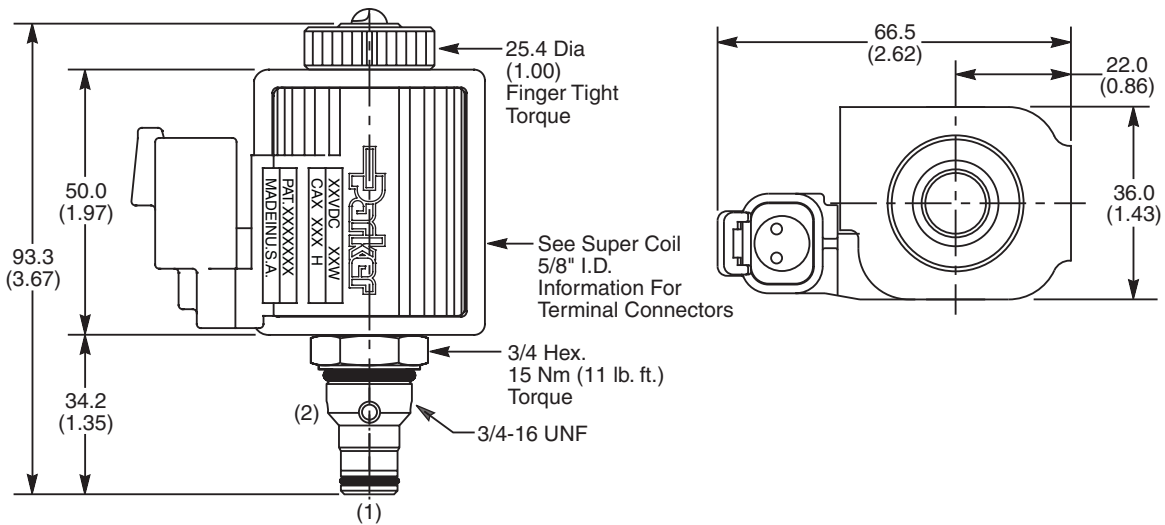

Ordering Information

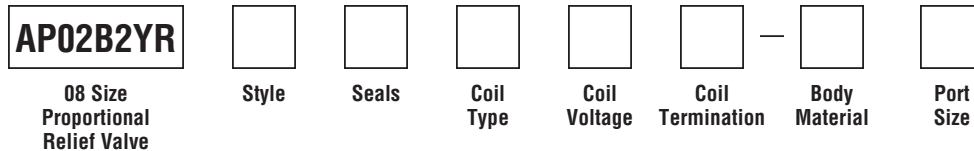

Code	Style (Maximum Relief Pressure)
07AL	70 Bar (1000 PSI)
14AL	140 Bar (2000 PSI)
21AL	210 Bar (3000 PSI)
35AL	350 Bar (5000 PSI)

Custom pressure setting available. Consult factory.

Code	Seals / Kit. No.
N	Nitrile / Buna-N (Std.) (SK30006N-1)
V	Fluorocarbon / (SK30006V-1)
E	Ethylene Propylene

Code	Coil Type
Omit	Without Coil
SP	Super Coil - 28 Watts

Code	Coil Voltage
Omit	Without Coil
D012	12 VDC
D024	24 VDC

Code	Coil Termination
Omit	Without Coil
D	DIN Plug Face
A	Amp Jr. Timer*
L	Dual Lead Wire*
LS	Sealed Lead Wire*
H	Molded Deutsch*

See Super Coil 5/8" I.D.
 *DC Only

Code	Body Material
Omit	Steel
A	Aluminum

Code	Port Size	Body Part No.
Omit	Cartridge Only	
4P	1/4" NPTF	(B08-2-*4P)
6P	3/8" NPTF	(B08-2-*6P)
4T	SAE-4	(B08-2-*4T)
6T	SAE-6	(B08-2-*6T)
6B	3/8" BSPG	(B08-2-*6B)

* Add "A" for aluminum, omit for steel.

- CV**
Check Valves
- SH**
Shuttle Valves
- LM**
Load/Motor Controls
- FC**
Flow Controls
- PC**
Pressure Controls
- LE**
Logic Elements
- DC**
Directional Controls
- MV**
Manual Valves
- SV**
Solenoid Valves
- PV**
Proportional Valves
- CE**
Coils & Electronics
- BC**
Bodies & Cavities
- TD**
Technical Data

Technical Information

- CV** Check Valves
- SH** Shuttle Valves
- LM** Load/Motor Controls
- FC** Flow Controls
- PC** Pressure Controls
- LE** Logic Elements
- DC** Directional Controls
- MV** Manual Valves
- SV** Solenoid Valves
- PV** Proportional Valves
- CE** Coils & Electronics
- BC** Bodies & Cavities
- TD** Technical Data

General Description

Proportional Relief Valve. Decreasing Pressure With Increasing Current. For additional information see Technical Tips on pages PV1-PV6.

Features

- Pilot operated spool-type design
- Precise setting of factory preset pressure in de-energized mode
- One piece cartridge housing ensures internal concentricity
- Coil: Waterproof, hermetically sealed, requires no O'Rings; Symmetrical coil can be reversed without affecting performance.

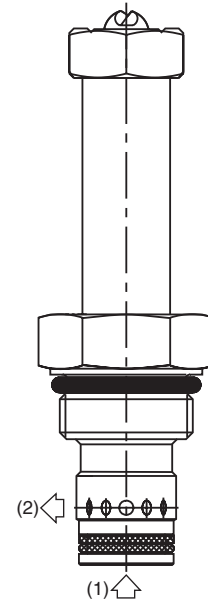
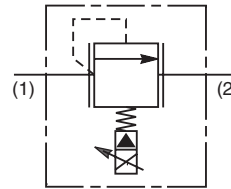
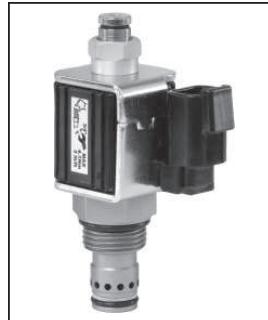

Specifications

Rated Flow (At 300 PSI ΔP) When Coil is Fully Energized	95 LPM (25 GPM)	
Factory Set Relief Pressure When Coil De-Energized Measured at 45 LPM (12 GPM)	10C	103 Bar (1500 PSI)
	21C	210 Bar (3000 PSI)
	35C	350 Bar (5000 PSI)
Hysteresis @ 250 Hz PWM	< 7% of Maximum Pressure Setting	
Response Time At 75% of Nominal Voltage Change (Measured To 90% of Press. Change)	To Unload	45ms
	To Load	25ms
Cartridge Material	All parts steel. All operating parts hardened steel.	
Operating Temp. Range/Seals	-40°C to +93.3°C (Nitrile) (-40°F to +200°F) -31.7°C to +121.1°C (Fluorocarbon) (-25°F to +250°F)	
Fluid Compatibility/ Viscosity	Mineral-based or synthetic with lubricating properties at viscosities of 45 to 2000 SSU (6 to 420 cSt)	
Filtration	ISO Code 16/13, SAE Class 4 or better	
Approx. Weight	.14 kg (.30 lbs.)	
Cavity	C10-2 (See BC Section for more details)	

Performance Curves

▲ PWM Current Regulator Recommended

Relief Performance

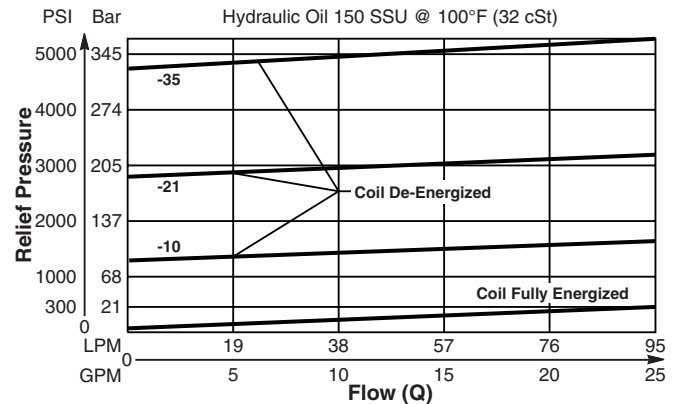

Pressure vs. Input Current

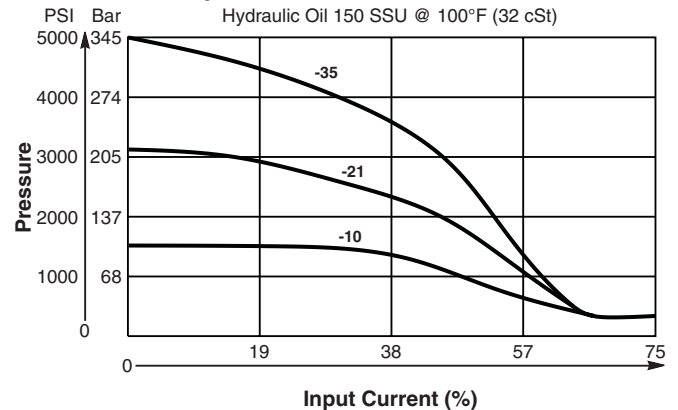

Dimensions Millimeters (Inches)

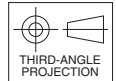
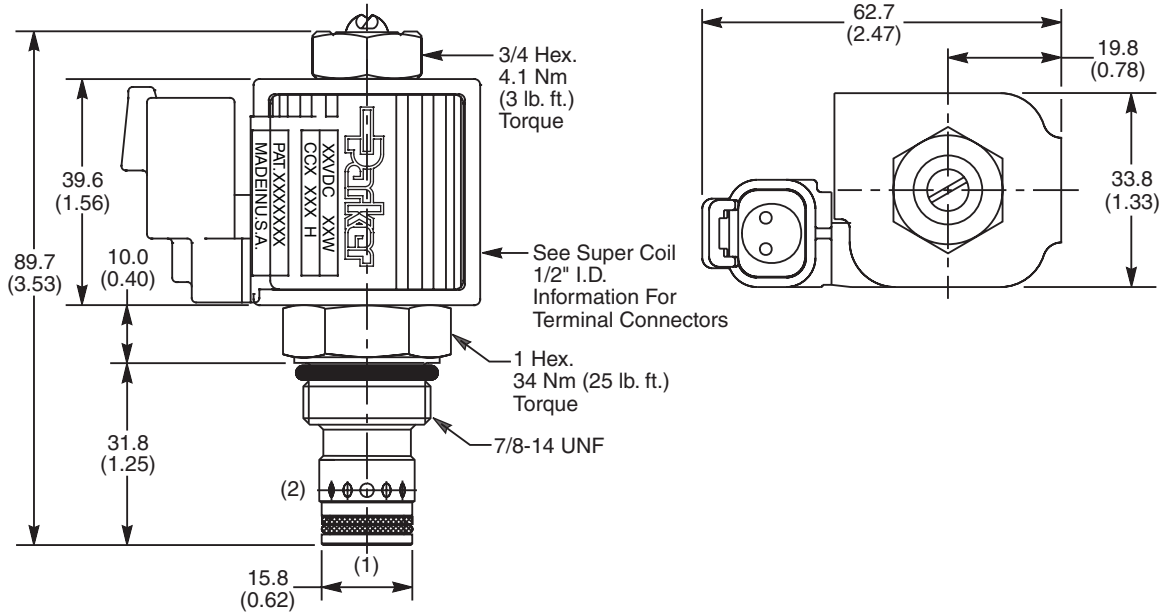

Ordering Information

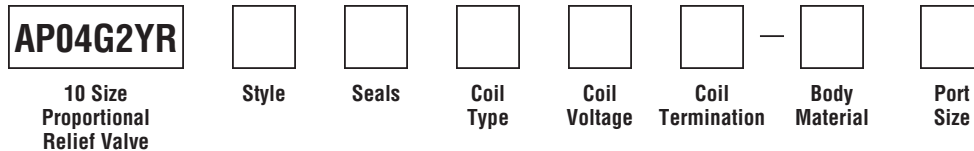

Code	Style (Maximum Relief Pressure)
10C	104 Bar (1500 PSI)
21C	210 Bar (3000 PSI)
35C	350 Bar (5000 PSI)

Custom pressure setting available. Consult factory.

Code	Seals / Kit. No.
N	Nitrile / Buna-N (Std.) (SK30503N-1)
V	Fluorocarbon / (SK30503V-1)

Code	Coil Type
Omit	Without Coil
SP	Super Coil - 19 Watts

Code	Coil Voltage
Omit	Without Coil
D012	12 VDC
D024	24 VDC

Code	Coil Termination
Omit	Without Coil
D	DIN Plug Face
A	Amp Jr. Timer*
L	Dual Lead Wire*
LS	Sealed Lead Wire*
H	Molded Deutsch*

See Super Coil 1/2" I.D.
 *DC Only

Code	Body Material
Omit	Steel
A	Aluminum

Code	Port Size	Body Part No.
Omit	Cartridge Only	
4P	1/4" NPTF	(B10-2-*4P)
6P	3/8" NPTF	(B10-2-*6P)
8P	1/2" NPTF	(B10-2-*8P)
6T	SAE-6	(B10-2-*6T)
8T	SAE-8	(B10-2-*8T)
T8T	SAE-8	(B10-2-T8T)†
6B	3/8" BSPG	(B10-2-*6B)

* Add "A" for aluminum, omit for steel.
 † Steel body only.

- CV
- Check Valves
- SH
- Shuttle Valves
- LM
- Load/Motor Controls
- FC
- Flow Controls
- PC
- Pressure Controls
- LE
- Logic Elements
- DC
- Directional Controls
- MV
- Manual Valves
- SV
- Solenoid Valves
- PV
- Proportional Valves
- CE
- Coils & Electronics
- BC
- Bodies & Cavities
- TD
- Technical Data

Technical Information

- CV** Check Valves
- SH** Shuttle Valves
- LM** Load/Motor Controls
- FC** Flow Controls
- PC** Pressure Controls
- LE** Logic Elements
- DC** Directional Controls
- MV** Manual Valves
- SV** Solenoid Valves
- PV** Proportional Valves
- CE** Coils & Electronics
- BC** Bodies & Cavities
- TD** Technical Data

General Description

3 Way, 2 Position, Proportional Pressure Reducing Valve. Bottom Cylinder Port. For additional information see Technical Tips on pages PV1-PV6.

Features

- Designed for pilot control of directional valves
- Low Hysteresis
- One piece cartridge housing ensures internal concentricity
- Coil: Waterproof, hermetically sealed, requires no O’Rings; Symmetrical coil can be reversed without affecting performance.

Specifications

Rated Flow (At 70 PSI ΔP)	1.9 LPM (0.5 GPM)
Max. Regulated Pressure @ 75% Current	Standard 17 Bar (250 PSI) High Pressure 22 Bar (320 PSI)
Max. Input Press. At Port 1	210 Bar (3000 PSI)
Max. Tank Press.	30 Bar (440 PSI)
Max. Drainage Flow In Regulating Zone	5 cc/min. When De-Energized 200 cc/min. In Regulating Zone At 68 Bar (1000 PSI) Input Pressure
Hysteresis @ 200 Hz PWM	2%
Dead End Response Time	t on = 30 ms t off = 10 ms At Step Signal 0 To 75% of Nominal Voltage
Cartridge Material	All parts steel. All operating parts hardened steel.
Operating Temp. Range/Seals	-40°C to +93.3°C (Nitrile) (-40°F to +200°F) -31.7°C to +121.1°C (Fluorocarbon) (-25°F to +250°F)
Fluid Compatibility/ Viscosity	Mineral-based or synthetic with lubricating properties at viscosities of 45 to 2000 SSU (6 to 420 cSt)
Filtration	ISO Code 16/13, SAE Class 4 or better
Approx. Weight	.08 kg (.17 lbs.)
Cavity	54-1 (See BC Section for more details)

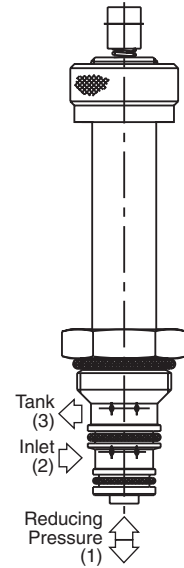
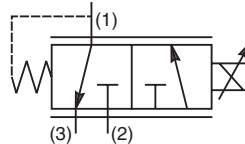

Performance Curves

▲ PWM Current Regulator Recommended

Pressure Drop vs. Flow

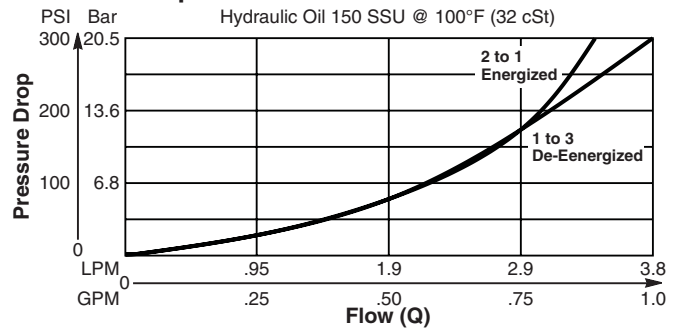

Pressure @ Port 1 vs. Input Current

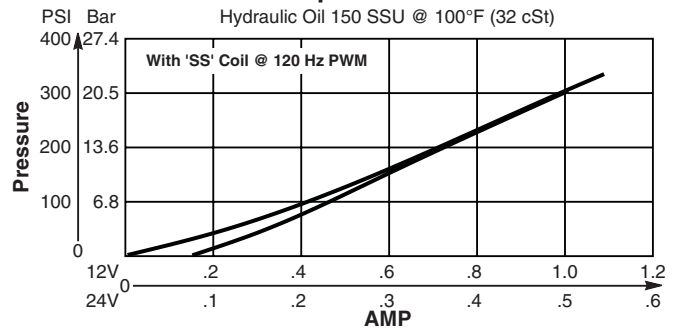

Pressure @ Port 1 vs. Input Current

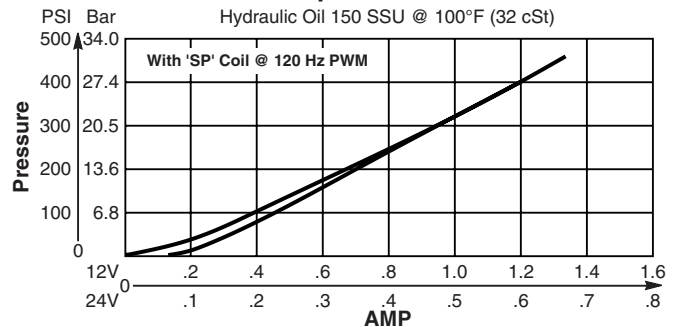

Dimensions Millimeters (Inches)

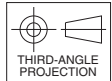
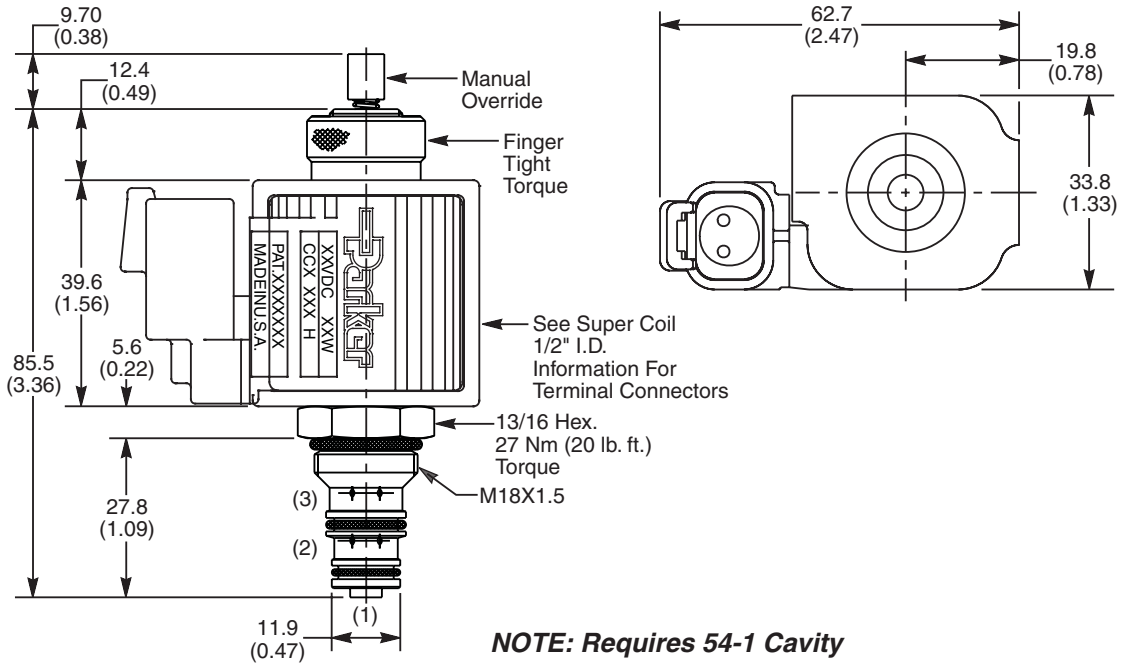

Ordering Information

GP01	30						
08 Size Proportional Valve	Style	Override Option	Filter Screen	Seals	Coil Type	Coil Voltage	Coil Termination

Code	Style
30	Standard ('SS' Coil)
30	High Pressure ('SP' Coil)

Code	Filter Screen
Omit	Not Required
F	60 Mesh Screen on Inlet Port

Code	Coil Type
Omit	Without Coil
SS	Super Coil - 14 Watts
SP	Super Coil - 19 Watts

Code	Coil Termination
Omit	Without Coil
D	DIN Plug Face
A	Amp Jr. Timer*
L	Dual Lead Wire*
LS	Sealed Lead Wire*
H	Molded Deutsch*

Code	Override Option
Omit	If No M.O.
1	Manual Override

Code	Seals / Kit No.
N	Nitrile / Buna-N (Std.) (SK30122N-1)
V	Fluorocarbon / (SK30122V-1)

Code	Coil Voltage
Omit	Without Coil
D012	12 VDC
D024	24 VDC

See Super Coil 1/2" I.D.
*DC Only

Order Bodies Separately

LB10		
Line Body	Porting	Body Material

Code	Porting
591	1/4" SAE

Code	Body Material
A	Aluminum
S	Steel



- CV**
Check Valves
- SH**
Shuttle Valves
- LM**
Load/Motor Controls
- FC**
Flow Controls
- PC**
Pressure Controls
- LE**
Logic Elements
- DC**
Directional Controls
- MV**
Manual Valves
- SV**
Solenoid Valves
- PV**
Proportional Valves
- CE**
Coils & Electronics
- BC**
Bodies & Cavities
- TD**
Technical Data

Technical Information

- CV** Check Valves
- SH** Shuttle Valves
- LM** Load/Motor Controls
- FC** Flow Controls
- PC** Pressure Controls
- LE** Logic Elements
- DC** Directional Controls
- MV** Manual Valves
- SV** Solenoid Valves
- PV** Proportional Valves
- CE** Coils & Electronics
- BC** Bodies & Cavities
- TD** Technical Data

General Description

3 Way, 2 Position, Proportional Pressure Reducing Valve. Side Cylinder Port. For additional information see Technical Tips on pages PV1-PV6.

Features

- Minimal Hysteresis
- One piece cartridge housing ensures internal concentricity
- Coil: Waterproof, hermetically sealed, requires no O’Rings; Symmetrical coil can be reversed without affecting performance.
- Nonmagnetic spool and housing assembly

Specifications

Rated Flow (At 70 PSI ΔP)	19 LPM (5 GPM)												
Max. Regulated Pressure @ 75% Current (Using ‘SP’ Coil)	<table style="border: none;"> <tr><td>02</td><td>12/17 Bar (180/240 PSI)</td></tr> <tr><td>03</td><td>19/26 Bar (270/375 PSI)</td></tr> <tr><td>05</td><td>31/40 Bar (450/580 PSI)</td></tr> <tr><td>06</td><td>41/51 Bar (600/740 PSI)</td></tr> <tr><td>09</td><td>65/79 Bar (940/1140 PSI)</td></tr> <tr><td>18</td><td>114/145 Bar (1650/2100 PSI)</td></tr> </table>	02	12/17 Bar (180/240 PSI)	03	19/26 Bar (270/375 PSI)	05	31/40 Bar (450/580 PSI)	06	41/51 Bar (600/740 PSI)	09	65/79 Bar (940/1140 PSI)	18	114/145 Bar (1650/2100 PSI)
02	12/17 Bar (180/240 PSI)												
03	19/26 Bar (270/375 PSI)												
05	31/40 Bar (450/580 PSI)												
06	41/51 Bar (600/740 PSI)												
09	65/79 Bar (940/1140 PSI)												
18	114/145 Bar (1650/2100 PSI)												
Max. Input Press. At Port 3	210 Bar (3000 PSI)												
Max. Drainage Flow In Regulating Zone	100 cc/min. When De-Energized 750 cc/min. In Regulating Zone At 21 Bar (300 PSI) Input Pressure												
Hysteresis @ 100 Hz PWM	3.5%												
Dead End Response Time	10 ms At Step Signal 0 To 75% of Nominal Voltage												
Cartridge Material	All parts steel. All operating parts hardened steel.												
Operating Temp. Range/Seals	-40°C to +93.3°C (Nitrile) (-40°F to +200°F) -31.7°C to +121.1°C (Fluorocarbon) (-25°F to +250°F)												
Fluid Compatibility/ Viscosity	Mineral-based or synthetic with lubricating properties at viscosities of 45 to 2000 SSU (6 to 420 cSt)												
Filtration	ISO Code 16/13, SAE Class 4 or better												
Approx. Weight	.08 kg (.17 lbs.)												
Cavity	C08-3 (See BC Section for more details)												

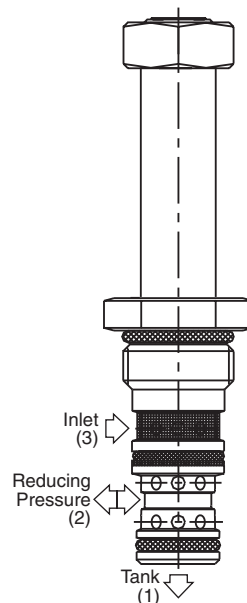
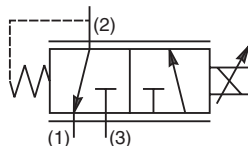

Performance Curves

▲ PWM Current Regulator Recommended

Pressure Drop vs. Flow

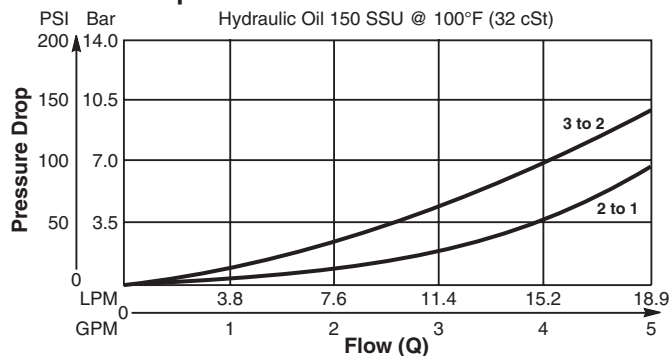

Pressure @ Port 2 vs. Input Current

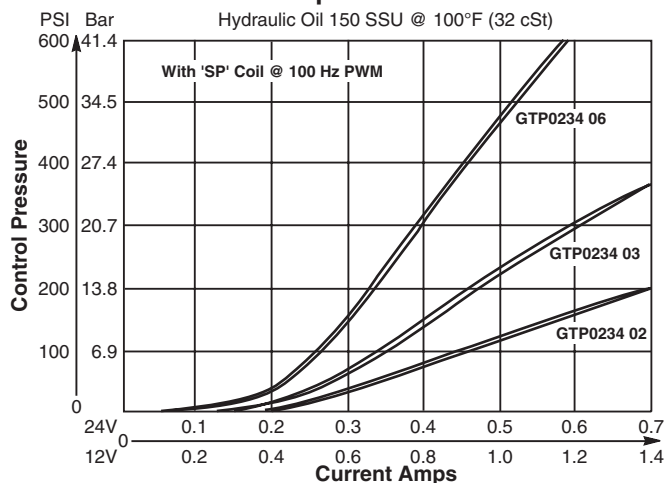

Dimensions Millimeters (Inches)

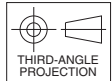
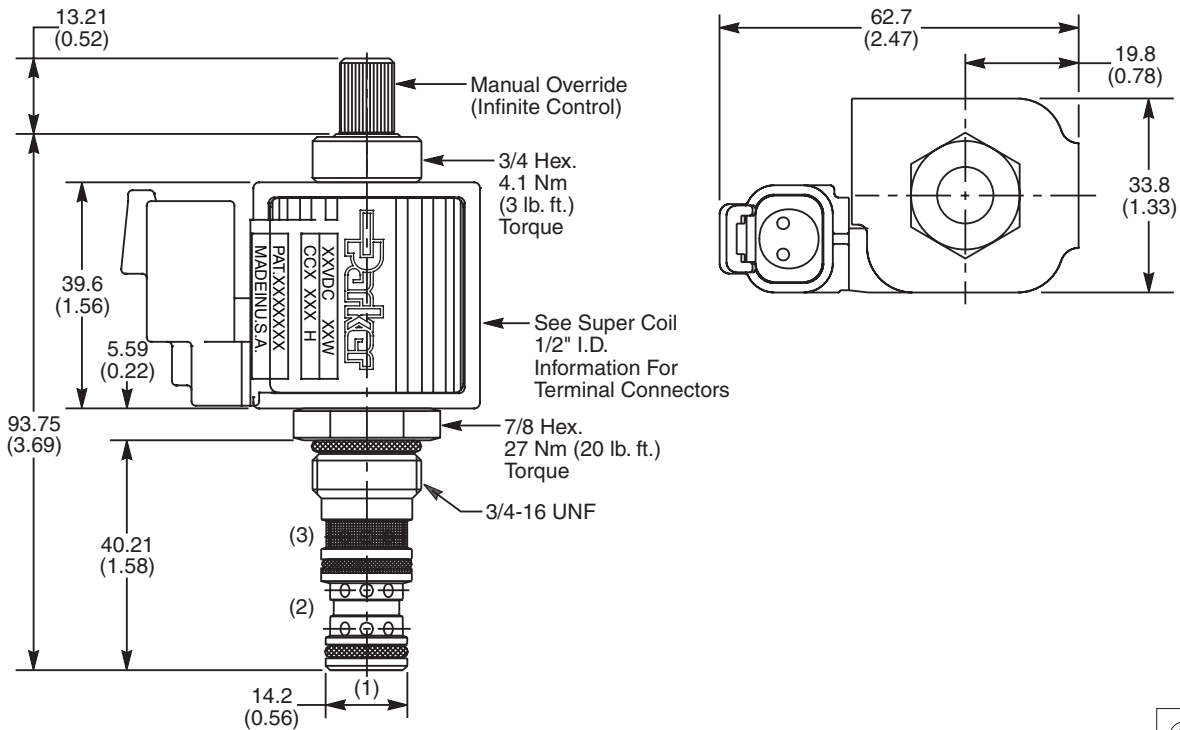

Ordering Information

08 Size Proportional Valve **Style** **Override Option** **Filter Screen** **Seals** **Coil Type** **Coil Voltage** **Coil Termination** **Body Material** **Port Size**

Code	Style (Maximum Regulated Pressure Range - SP COIL)
02	12/17 Bar (180/240 PSI)
03	19/26 Bar (270/375 PSI)
05	31/40 Bar (450/580 PSI)
06	41/51 Bar (600/740 PSI)
09	65/79 Bar (940/1140 PSI)
18	114/145 Bar (1650/2100 PSI)

Code	Filter Screen
1	60 Mesh Screen on Inlet Port

Code	Coil Voltage
Omit	Without Coil
D012	12 VDC
D024	24 VDC

Code	Body Material
Omit	Steel
A	Aluminum

Code	Override Option
0	Not Required
5	Detented M.O.

Code	Seals / Kit No.
N	Nitrile / Buna-N (Std.) (SK30081N-1)
V	Fluorocarbon / (SK30081V-1)

Code	Coil Termination
Omit	Without Coil
D	DIN Plug Face
A	Amp Jr. Timer*
L	Dual Lead Wire*
LS	Sealed Lead Wire*
H	Molded Deutsch*

Code	Port Size	Body Part No.
Omit	Cartridge Only	
4P	1/4" NPTF	(B08-3-*4P)
4T	SAE-4	(B08-3-*4T)
6T	SAE-6	(B08-3-*6T)
6B	3/8" BSPG	(B08-3-*6B)

* Add "A" for aluminum, omit for steel.

Code	Coil Type
Omit	Without Coil
SS	Super Coil - 14 Watts
SP	Super Coil - 19 Watts

See Super Coil 1/2" I.D.
 *DC Only

- CV Check Valves
- SH Shuttle Valves
- LM Load/Motor Controls
- FC Flow Controls
- PC Pressure Controls
- LE Logic Elements
- DC Directional Controls
- MV Manual Valves
- SV Solenoid Valves
- PV Proportional Valves
- CE Coils & Electronics
- BC Bodies & Cavities
- TD Technical Data

Technical Information

- CV** Check Valves
- SH** Shuttle Valves
- LM** Load/Motor Controls
- FC** Flow Controls
- PC** Pressure Controls
- LE** Logic Elements
- DC** Directional Controls
- MV** Manual Valves
- SV** Solenoid Valves
- PV** Proportional Valves
- CE** Coils & Electronics
- BC** Bodies & Cavities
- TD** Technical Data

General Description

3 Way, 2 Position, Proportional Pressure Reducing Valve. Side Cylinder Port. For additional information see Technical Tips on pages PV1-PV6.

Features

- Minimal Hysteresis
- One piece cartridge housing ensures internal concentricity
- Coil: Waterproof, hermetically sealed, requires no O’Rings; Symmetrical coil can be reversed without affecting performance.
- Nonmagnetic spool and housing assembly

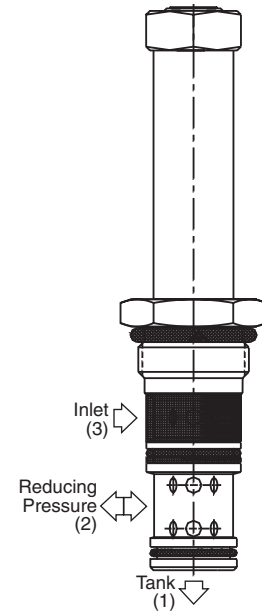
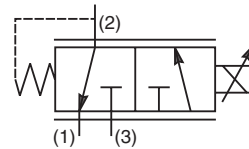

Specifications

Rated Flow (At 70 PSI ΔP)	30 LPM (8 GPM)								
Max. Regulated Pressure @ 75% Current (Using ‘SP’ Coil)	<table border="0"> <tr> <td>02</td> <td>14/17 Bar (200/240 PSI)</td> </tr> <tr> <td>03</td> <td>21/27 Bar (300/390 PSI)</td> </tr> <tr> <td>05</td> <td>29/38 Bar (420/550 PSI)</td> </tr> <tr> <td>09</td> <td>56/74 Bar (810/1080 PSI)</td> </tr> </table>	02	14/17 Bar (200/240 PSI)	03	21/27 Bar (300/390 PSI)	05	29/38 Bar (420/550 PSI)	09	56/74 Bar (810/1080 PSI)
02	14/17 Bar (200/240 PSI)								
03	21/27 Bar (300/390 PSI)								
05	29/38 Bar (420/550 PSI)								
09	56/74 Bar (810/1080 PSI)								
Max. Input Press. At Port 3	210 Bar (3000 PSI)								
Max. Drainage Flow In Regulating Zone	25 cc/min. When De-Energized 800 cc/min. In Regulating Zone At 21 Bar (300 PSI) Input Pressure								
Hysteresis @ 200 Hz PWM	3.5%								
Dead End Response Time	40 ms At Step Signal 0 To 75% of Nominal Voltage								
Cartridge Material	All parts steel. All operating parts hardened steel.								
Operating Temp. Range/Seals	-40°C to +93.3°C (Nitrile) (-40°F to +200°F) -31.7°C to +121.1°C (Fluorocarbon) (-25°F to +250°F)								
Fluid Compatibility/ Viscosity	Mineral-based or synthetic with lubricating properties at viscosities of 45 to 2000 SSU (6 to 420 cSt)								
Filtration	ISO Code 16/13, SAE Class 4 or better								
Approx. Weight	.13 kg (.28 lbs.)								
Cavity	3X (See BC Section for more details)								

Performance Curves

▲ PWM Current Regulator Recommended

Pressure Drop vs. Flow

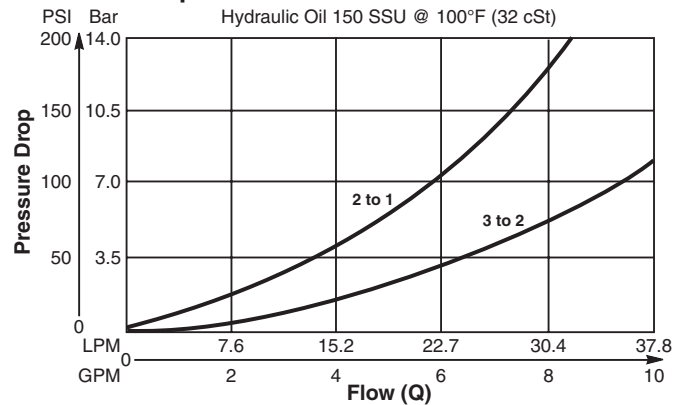

Pressure @ Port 2 vs. Input Current

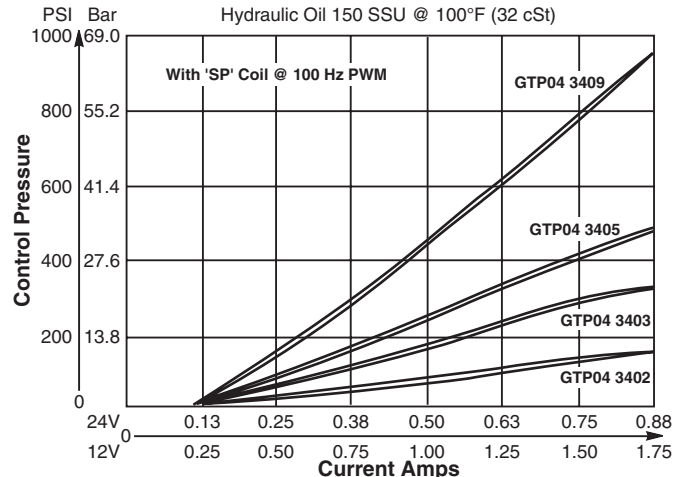

Dimensions Millimeters (Inches)

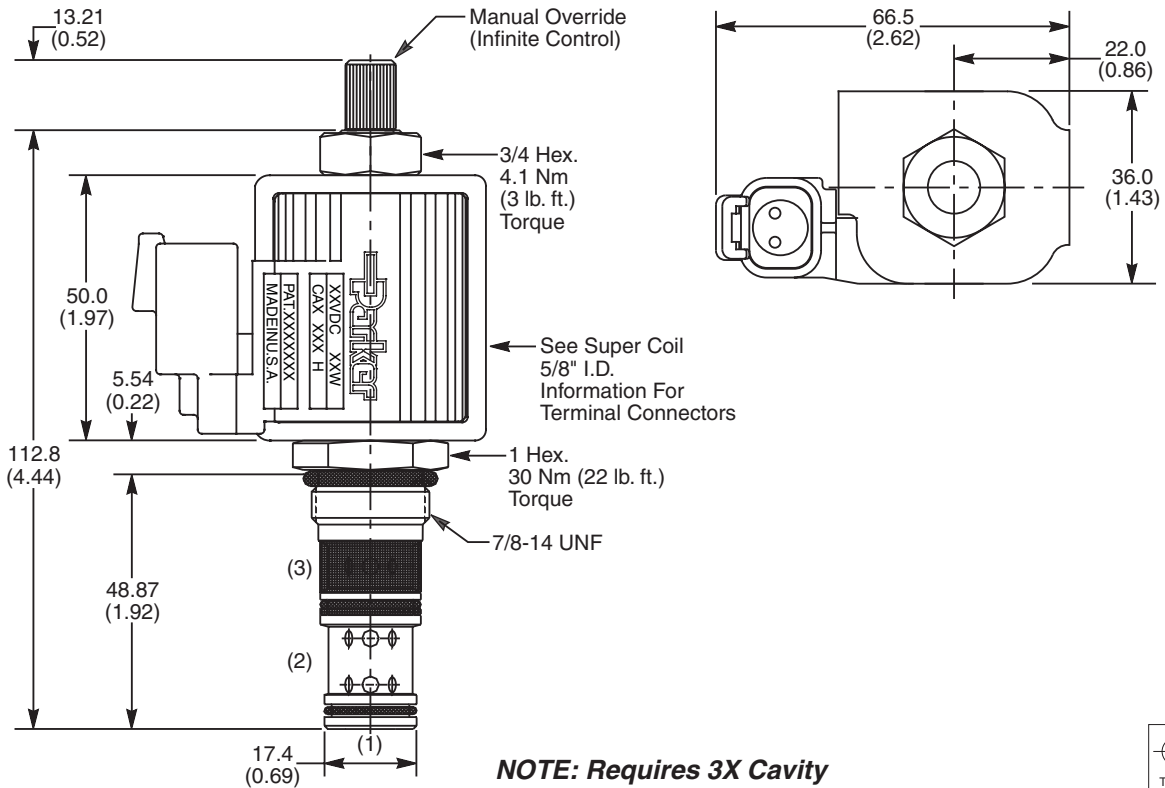

Ordering Information

GTP0434

10 Size Proportional Valve Style Override Option Filter Screen Seals Coil Type Coil Voltage Coil Termination

Code	Style (Maximum Regulated Pressure Range - SP Coil)
02	14/17 Bar (200/240 PSI)
03	21/27 Bar (300/390 PSI)
05	29/38 Bar (420/550 PSI)
09	56/74 Bar (810/1080 PSI)

Contact factory for other regulated pressure to 124 Bar (1800 PSI)

Code	Override Option
0	Not Required
5	Detented M.O.

Code	Filter Screen
1	60 Mesh Screen on Inlet Port

Code	Seals / Kit No.
N	Nitrile / Buna-N (Std.) (SK30081N-1)
V	Fluorocarbon / (SK30081V-1)

Code	Coil Type
Omit	Without Coil
SS	Super Coil - 18 Watts
SP	Super Coil - 28 Watts

Code	Coil Voltage
Omit	Without Coil
D012	12 VDC
D024	24 VDC

Code	Coil Termination
Omit	Without Coil
D	DIN Plug Face
A	Amp Jr. Timer*
L	Dual Lead Wire*
LS	Sealed Lead Wire*
H	Molded Deutsch*

See Super Coil 5/8" I.D.
*DC Only

Order Bodies Separately

LB10

Line Body Porting Body Material

Code	Porting
553	1/2" SAE
554	3/8" BSP

Code	Body Material
A	Aluminum
S	Steel



- CV
- Check Valves
- SH
- Shuttle Valves
- LM
- Load/Motor Controls
- FC
- Flow Controls
- PC
- Pressure Controls
- LE
- Logic Elements
- DC
- Directional Controls
- MV
- Manual Valves
- SV
- Solenoid Valves
- PV
- Proportional Valves
- CE
- Coils & Electronics
- BC
- Bodies & Cavities
- TD
- Technical Data

Technical Information

- CV** Check Valves
- SH** Shuttle Valves
- LM** Load/Motor Controls
- FC** Flow Controls
- PC** Pressure Controls
- LE** Logic Elements
- DC** Directional Controls
- MV** Manual Valves
- SV** Solenoid Valves
- PV** Proportional Valves
- CE** Coils & Electronics
- BC** Bodies & Cavities
- TD** Technical Data

General Description

Normally Closed Proportional Flow Control Valve. For additional information see Technical Tips on pages PV1-PV6.

Features

- On-off type solenoids
- Low hysteresis
- PWM signal preferred
- Manual override standard
- All external parts zinc plated

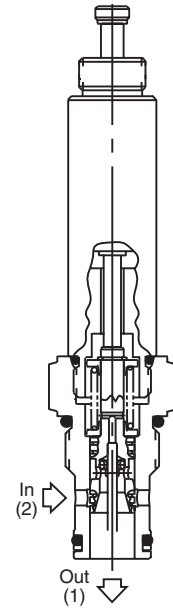
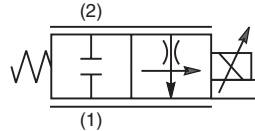
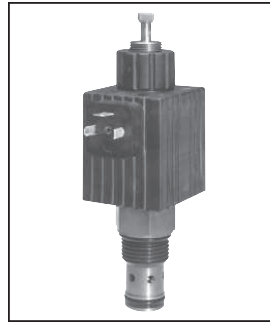

Specifications

Rated Flow Valve Fully Open	53 LPM (14 GPM)
Maximum Inlet Pressure	210 Bar (3000 PSI)
Hysteresis @ 200 Hz PWM	4%
Cracking (Dead band)	20% - 30% of Input Signal
Frequency	100 - 400 Hz (200 Hz Preferred)
Maximum Control Current	12 VDC 2.45A 24VDC 1.23A
Cartridge Material	All parts steel. All operating parts hardened steel.
Operating Temp. Range/Seals	-40°C to +93.3°C (Nitrile) (-40°F to +200°F) -31.7°C to +121.1°C (Fluorocarbon) (-25°F to +250°F)
Fluid Compatibility/Viscosity	Mineral-based or synthetic with lubricating properties at viscosities of 45 to 2000 SSU (6 to 420 cSt)
Filtration	ISO Code 16/13, SAE Class 4 or better
Approx. Weight	.32 kg (0.7 lbs.)
Cavity	C12-2 (See BC Section for more details)
Form Tool	Rougher None Finisher NFT12-2F

Performance Curves

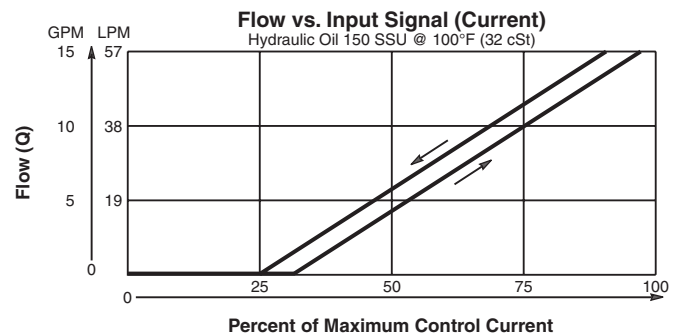
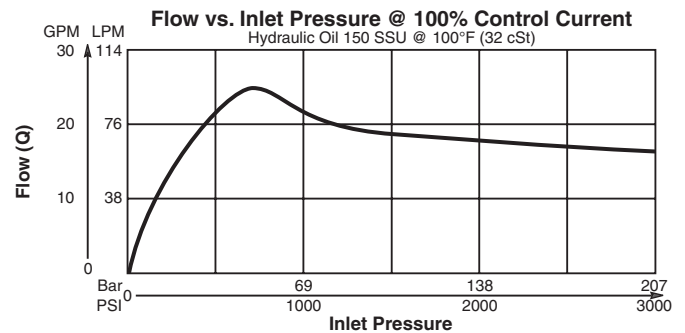
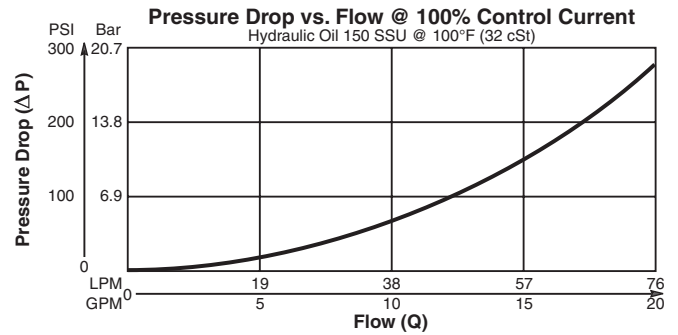

Dimensions Millimeters (Inches)

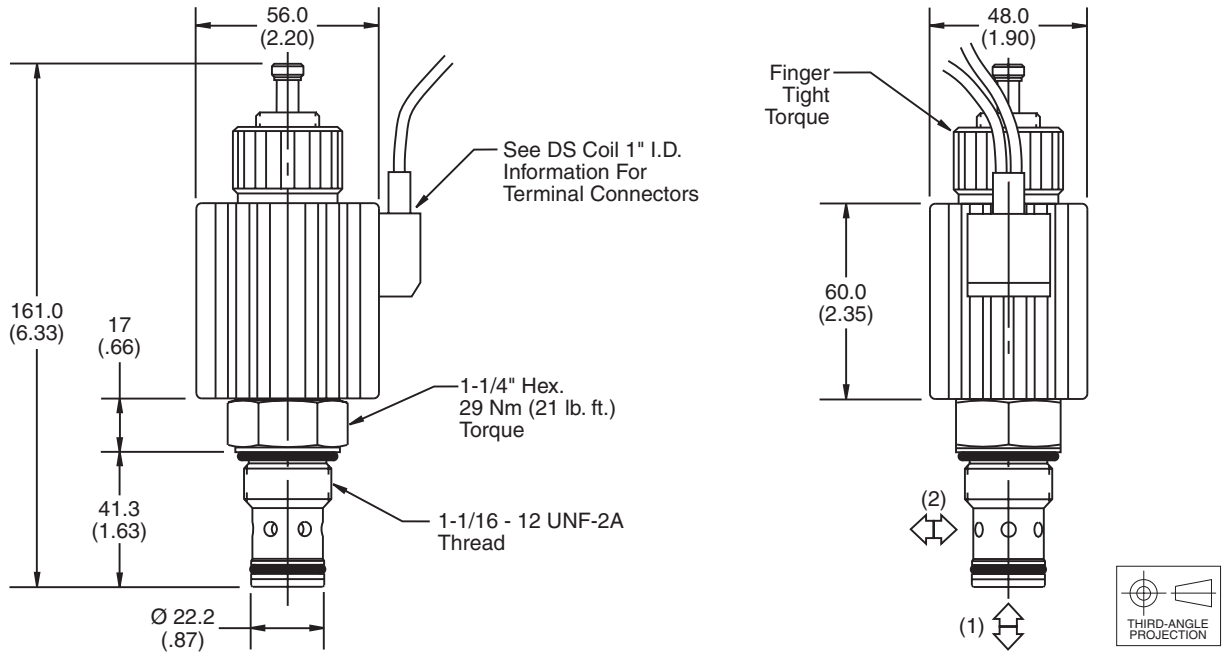

Ordering Information

DF122C14

12 Size Normally Closed Proportional Flow Control Valve

Override Options **Seals** **Coil Voltage** **Coil Wattage** **Coil Termination** **Body Material** **Port Size**

Code	Override Options
Omit	Push Type with Extended Rod

Code	Coil Voltage
Omit	Cartridge without Coil
D012	12 VDC
D024	24 VDC

Code	Coil Termination
Omit	Cartridge without Coil
D	DIN
P	Dual Spade
W	Dual Wire

See DS Coil 1" I.D.

Code	Body Material
Omit	Steel
A	Aluminum

Code	Seals / Kit. No.
Omit	Nitrile / (SK12-2)
V	Fluorocarbon / (SK12-2V)

Code	Coil Wattage
Omit	Cartridge without Coil
H	High Watt

Code	Port Size	Body Part No.
12P	3/4" NTPF	(B12-2-*12P)
8T	SAE - 8	(B12-2-*8T)
12T	SAE - 12	(B12-2-*12T)

** Add "A" for aluminum, omit for steel.*

- CV** Check Valves
- SH** Shuttle Valves
- LM** Load/Motor Controls
- FC** Flow Controls
- PC** Pressure Controls
- LE** Logic Elements
- DC** Directional Controls
- MV** Manual Valves
- SV** Solenoid Valves
- PV** Proportional Valves
- CE** Coils & Electronics
- BC** Bodies & Cavities
- TD** Technical Data

Technical Information

- CV** Check Valves
- SH** Shuttle Valves
- LM** Load/Motor Controls
- FC** Flow Controls
- PC** Pressure Controls
- LE** Logic Elements
- DC** Directional Controls
- MV** Manual Valves
- SV** Solenoid Valves
- PV** Proportional Valves
- CE** Coils & Electronics
- BC** Bodies & Cavities
- TD** Technical Data

General Description

Normally Closed Proportional Needle Valve. This valve is designed specifically for bleed off or unloading circuits. Back pressure will affect performance. For additional information see Technical Tips on pages PV1-PV6.

Features

- On-off type solenoids
- Low hysteresis
- PWM signal preferred
- All external parts zinc plated

Specifications

Rated Flow Valve Fully Open	High Watt Coil 150 LPM (40 GPM)
Maximum Inlet Pressure	210 Bar (3000 PSI)
Leakage at 150 SSU (32 cSt)	125 cc/min. (7.6 in ³ /min.)
Hysteresis @ 200 Hz PWM	4%
Cracking (Dead band)	20% - 30% of Input Signal
Frequency	100 - 400 Hz (200 Hz Preferred)
Maximum Control Current	12 VDC 24VDC High Watt 2.45A 1.23A
Cartridge Material	All parts steel. All operating parts hardened steel.
Operating Temp. Range/Seals	-40°C to +93.3°C (Nitrile) (-40°F to +200°F) -31.7°C to +121.1°C (Fluorocarbon) (-25°F to +250°F)
Fluid Compatibility/ Viscosity	Mineral-based or synthetic with lubricating properties at viscosities of 45 to 2000 SSU (6 to 420 cSt)
Filtration	ISO Code 16/13, SAE Class 4 or better
Approx. Weight	.34 kg (0.75 lbs.)
Cavity	C16-2 (See BC Section for more details)
Form Tool	Rougher None Finisher NFT16-2F

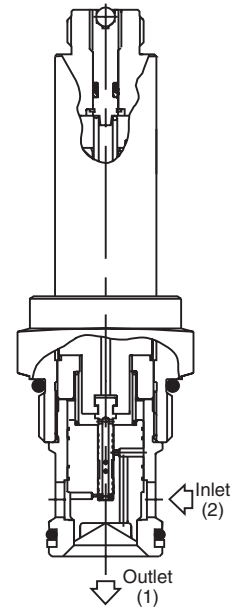
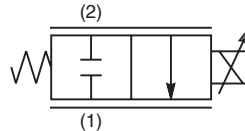
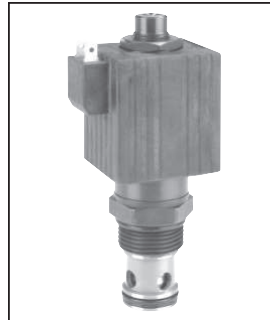

Performance Curves

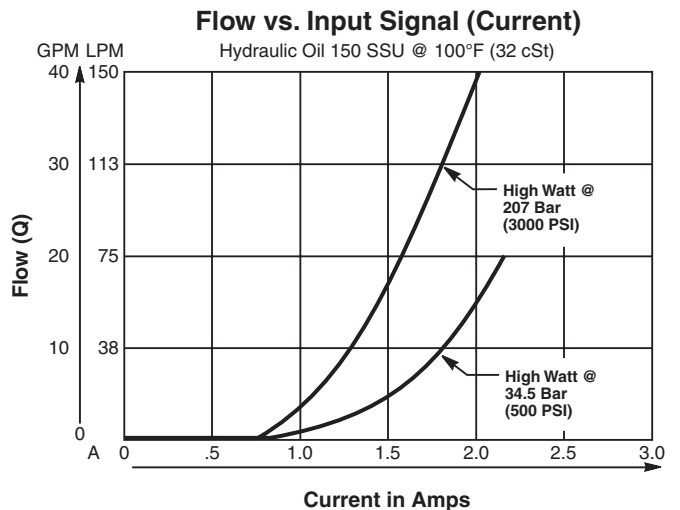
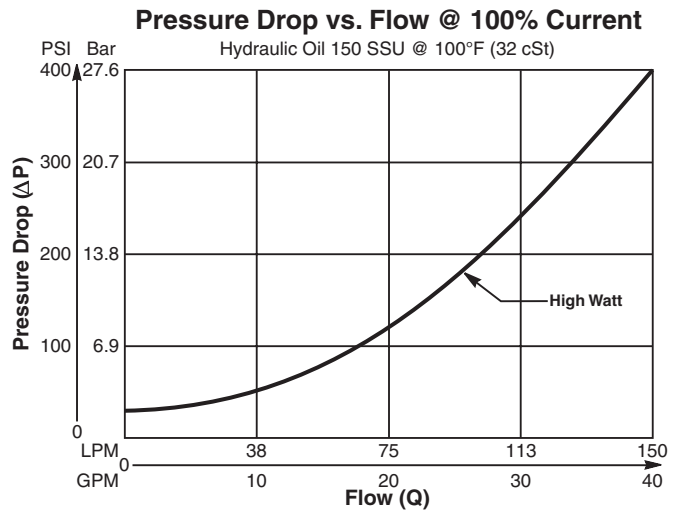

Dimensions Millimeters (Inches)

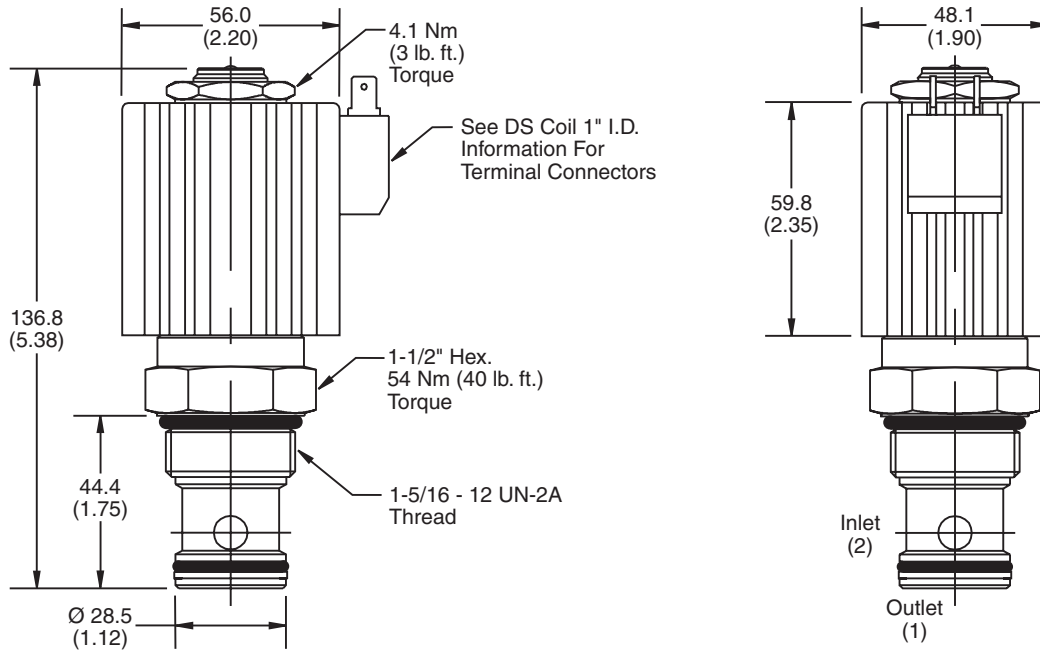

Ordering Information

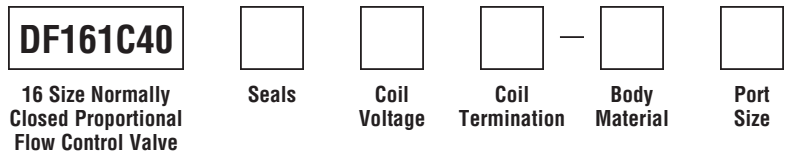

Code	Seals / Kit. No.
Omit	Nitrile / (SK16-2)
V	Fluorocarbon / (SK16-2V)

Code	Coil Voltage
Omit	Cartridge without Coil
D012	12 VDC
D024	24 VDC

Code	Coil Termination
Omit	Cartridge without Coil
D	DIN
P	Dual Spade
W	Dual Wire

See DS Coil 1" I.D

Code	Body Material
Omit	Steel
A	Aluminum

Code	Port Size	Body Part No.
12P	3/4" NTPF	(B16-2-*12P)
16P	1" NTPF	(B16-2-*16P)
8T	SAE - 8	(B16-2-*8T)
12T	SAE - 12	(B16-2-*12T)
16T	SAE - 16	(B16-2-*16T)
12B	3/4" BSPG	(B16-2-12B)†
16B	1" BSPG	(B16-2-*16B)

* Add "A" for aluminum, omit for steel.
 † Steel body only.

- CV
- Check Valves
- SH
- Shuttle Valves
- LM
- Load/Motor Controls
- FC
- Flow Controls
- PC
- Pressure Controls
- LE
- Logic Elements
- DC
- Directional Controls
- MV
- Manual Valves
- SV
- Solenoid Valves
- PV
- Proportional Valves
- CE
- Coils & Electronics
- BC
- Bodies & Cavities
- TD
- Technical Data

Technical Information

- CV** Check Valves
- SH** Shuttle Valves
- LM** Load/Motor Controls
- FC** Flow Controls
- PC** Pressure Controls
- LE** Logic Elements
- DC** Directional Controls
- MV** Manual Valves
- SV** Solenoid Valves
- PV** Proportional Valves
- CE** Coils & Electronics
- BC** Bodies & Cavities
- TD** Technical Data

General Description

Normally Closed Proportional Needle Valve. This valve is designed specifically for bleed off or unloading circuits. Back pressure will affect performance. For additional information see Technical Tips on pages PV1-PV6.

Features

- On-off type solenoids
- Low hysteresis
- PWM signal preferred
- All external parts zinc plated

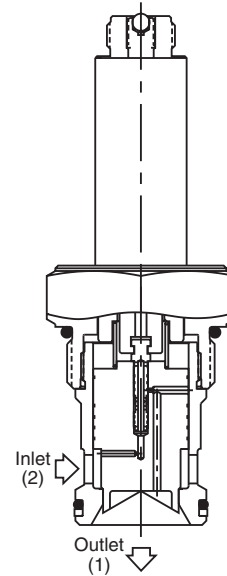
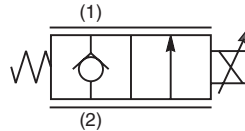
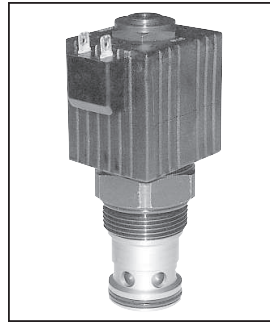

Specifications

Rated Flow Valve Fully Open	Low Watt 180 LPM (48 GPM) High Watt 227 LPM (60 GPM)
Maximum Inlet Pressure	210 Bar (3000 PSI)
Leakage at 150 SSU (32 cSt)	125 cc/min. (7.6 in ³ /min.)
Hysteresis @ 200 Hz PWM	4%
Cracking (Dead band)	20% - 30% of Input Signal
Frequency	100 - 400 Hz (200 Hz Preferred)
Maximum Control Current	12 VDC 24VDC Low Watt 1.75A .91A High Watt 2.45A 1.23A
Cartridge Material	All parts steel. All operating parts hardened steel.
Operating Temp. Range/Seals	-40°C to +93.3°C (Nitrile) (-40°F to +200°F) -31.7°C to +121.1°C (Fluorocarbon) (-25°F to +250°F)
Fluid Compatibility/Viscosity	Mineral-based or synthetic with lubricating properties at viscosities of 45 to 2000 SSU (6 to 420 cSt)
Filtration	ISO Code 16/13, SAE Class 4 or better
Approx. Weight	.34 kg (0.75 lbs.)
Cavity	C20-2 (See BC Section for more details)
Form Tool	Rougher None Finisher NFT20-2F

Performance Curves

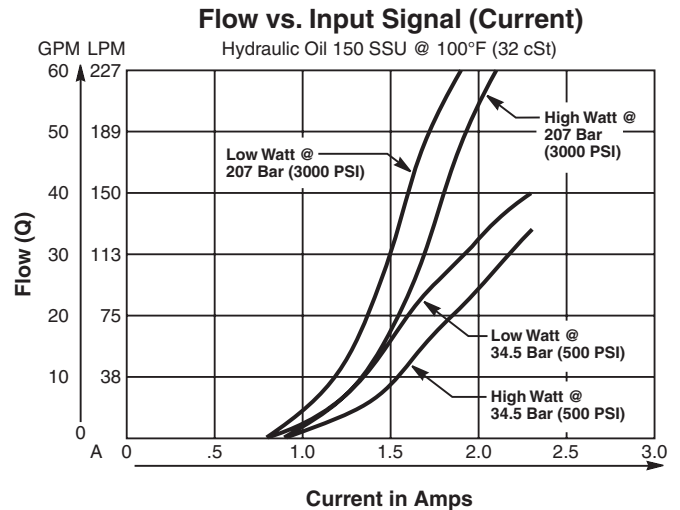
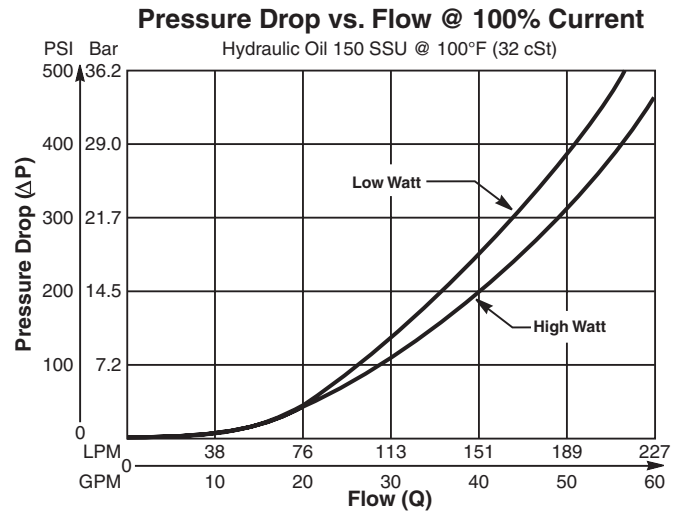

Technical Information

Dimensions Millimeters (Inches)

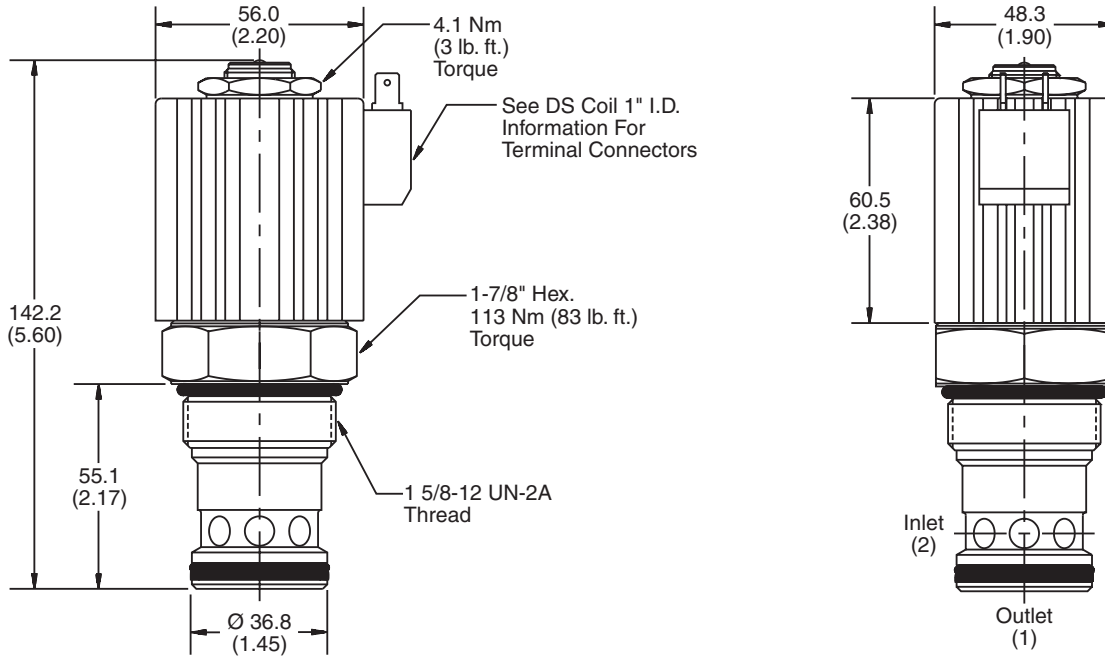

Ordering Information

DF201C60

20 Size Normally Closed Proportional Flow Control Valve

Seals Coil Voltage Coil Wattage Coil Termination Body Material Port Size

Code	Seals / Kit. No.
Omit	Nitrile / (SK20-2)
V	Fluorocarbon / (SK20-2V)

Code	Coil Voltage
Omit	Cartridge without Coil
D012	12 VDC
D024	24 VDC

Code	Coil Termination
Omit	Cartridge without Coil
D	DIN
P	Dual Spade
W	Dual Wire

Code	Body Material
Omit	Steel
A	Aluminum

Code	Coil Wattage
Omit	Cartridge without Coil
L	Low Watt
H	High Watt

See DS Coil 1" I.D.

Code	Port Size	Body Part No.
20T	SAE - 20	(B20-2-*20T)
20B	1-1/4" BSPG	(B20-2-*20B)

* Add "A" for aluminum, omit for steel.

- CV
Check Valves
- SH
Shuttle Valves
- LM
Load/Motor Controls
- FC
Flow Controls
- PC
Pressure Controls
- LE
Logic Elements
- DC
Directional Controls
- MV
Manual Valves
- SV
Solenoid Valves
- PV
Proportional Valves
- CE
Coils & Electronics
- BC
Bodies & Cavities
- TD
Technical Data

Technical Information

- CV** Check Valves
- SH** Shuttle Valves
- LM** Load/Motor Controls
- FC** Flow Controls
- PC** Pressure Controls
- LE** Logic Elements
- DC** Directional Controls
- MV** Manual Valves
- SV** Solenoid Valves
- PV** Proportional Valves
- CE** Coils & Electronics
- BC** Bodies & Cavities
- TD** Technical Data

General Description

2 Way, Normally Closed, Proportional Flow Regulator Valve. Partially Pressure Compensated. For additional information see Technical Tips on pages PV1-PV6.

Features

- Analog Proportional Partially Pressure Compensated Flow Regulator regulates flow proportionally to the input solenoid current.
- A low cost valve designed to be used in applications where fine pressure compensation is not required.
- One piece cartridge housing ensures internal concentricity
- Coil: Waterproof, hermetically sealed, requires no O’Rings; Symmetrical coil can be reversed without affecting performance.
- Nonmagnetic spool and housing assembly
- Factory-adjusted low variation option (Model “L”) is available for applications where low variation of flow from valve to valve is essential at a given current or when an external pressure compensator is used.

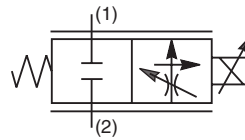
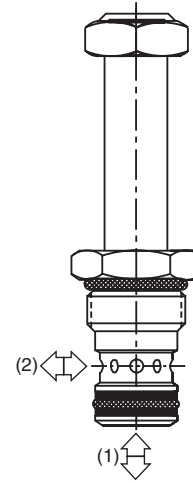

Specifications

Rated Flow @ 210 Bar (3000 PSI)	Standard (‘SS’ Coil) 2 to 1 13.3 LPM (3.5 GPM) 1 to 2 9.5 LPM (2.5 GPM) High Flow (‘SP’ Coil) 2 to 1 22.8 LPM (6.0 GPM) 1 to 2 15.0 LPM (4.0 GPM)
Preferable Input Port For Best Hysteresis	Port 1
Hysteresis @ 100 Hz PWM	<10%
Cracking Pressure	25% of Input Current
Variation of Flow @ 35% of Rated Current & Constant ΔP Maintained By Pressure Compensator	Standard Model Up To ±20% Of Rated Flow Model “L” ±7% Of Rated Flow
Cartridge Material	All parts steel. All operating parts hardened steel.
Operating Temp. Range/Seals	-40°C to +93.3°C (Nitrile) (-40°F to +200°F) -31.7°C to +121.1°C (Fluorocarbon) (-25°F to +250°F)
Fluid Compatibility/ Viscosity	Mineral-based or synthetic with lubricating properties at viscosities of 45 to 2000 SSU (6 to 420 cSt)
Filtration	ISO Code 16/13, SAE Class 4 or better
Approx. Weight	.08 kg (.17 lbs.)
Cavity	2X (See BC Section for more details)

Performance Curves

▲ PWM Current Regulator Recommended

Flow vs. Input Current

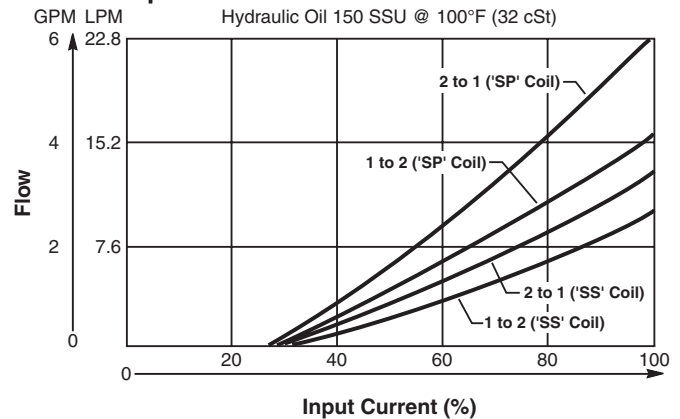

Flow Regulation (Measured at 75% of Rated Current)

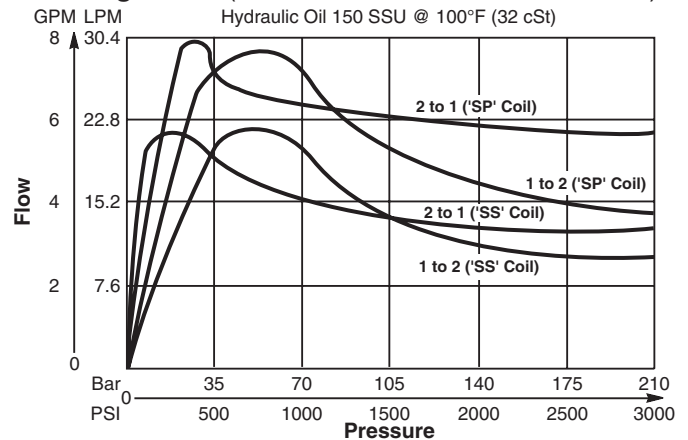

Dimensions Millimeters (Inches)

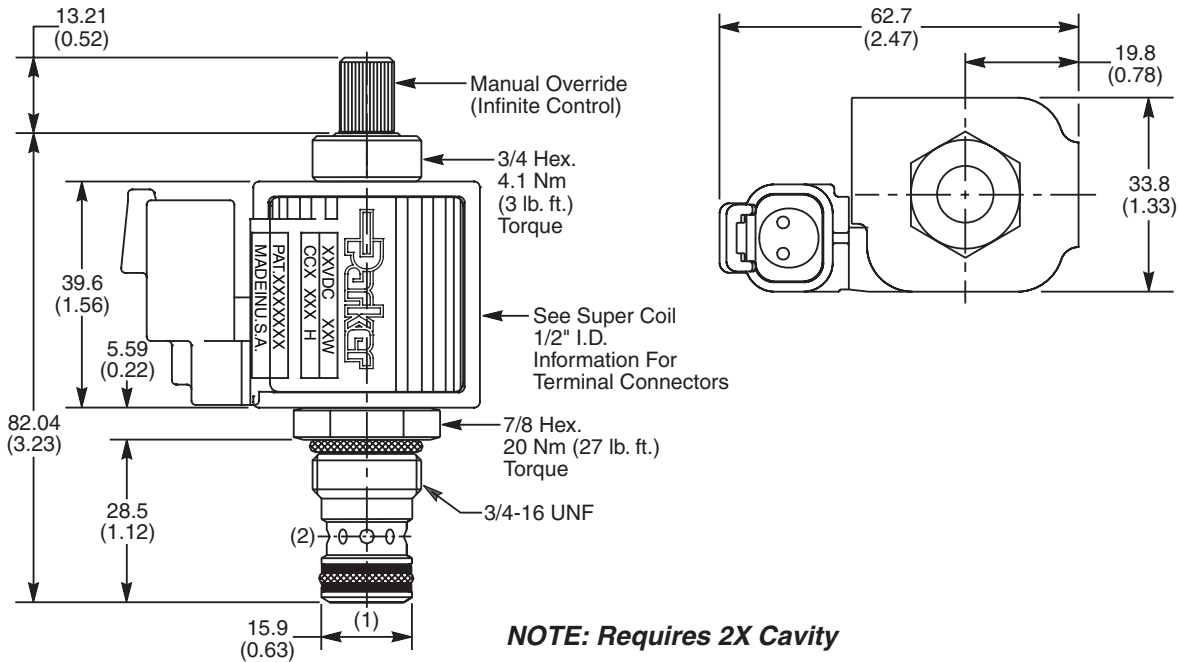

NOTE: Requires 2X Cavity

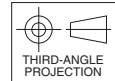

Ordering Information

HP02C	21							
08 Size Proportional Valve	Style	Override Option	Filter Screen	Seals	Flow Variation	Coil Type	Coil Voltage	Coil Termination

Code	Style (Maximum Regulated Flow)
21	Standard ('SS' Coil) 13.3 LPM (3.5 GPM)
21	High Flow ('SP' Coil) 22.8 LPM (6.0 GPM)

Code	Filter Screen
0	Not Available

Code	Seals / Kit No.
N	Nitrile / Buna-N (Std.) (SK30076N-1)
V	Fluorocarbon / (SK30076V-1)

Code	Flow Variation
Omit	Standard Up to ±20% of Rated Flow
L	Low Variation (±7% of Rated Flow)

Code	Coil Voltage
Omit	Without Coil
D012	12 VDC
D024	24 VDC

Code	Override Option
0	Not Required
5	Detented M.O. (Infinite Control)

Code	Coil Type
Omit	Without Coil
SS	Super Coil - 14 Watts
SP	Super Coil - 19 Watts

Code	Coil Termination
Omit	Without Coil
D	DIN Plug Face
A	Amp Jr. Timer*
L	Dual Lead Wire*
LS	Sealed Lead Wire*
H	Molded Deutsch*

See Super Coil 1/2" I.D.
*DC Only

Order Bodies Separately

LB10		
Line Body	Porting	Body Material

Code	Porting
513	3/8" SAE
515	1/4" BSP

Code	Body Material
A	Aluminum
S	Steel



- CV**
Check Valves
- SH**
Shuttle Valves
- LM**
Load/Motor Controls
- FC**
Flow Controls
- PC**
Pressure Controls
- LE**
Logic Elements
- DC**
Directional Controls
- MV**
Manual Valves
- SV**
Solenoid Valves
- PV**
Proportional Valves
- CE**
Coils & Electronics
- BC**
Bodies & Cavities
- TD**
Technical Data

Technical Information

- CV** Check Valves
- SH** Shuttle Valves
- LM** Load/Motor Controls
- FC** Flow Controls
- PC** Pressure Controls
- LE** Logic Elements
- DC** Directional Controls
- MV** Manual Valves
- SV** Solenoid Valves
- PV** Proportional Valves
- CE** Coils & Electronics
- BC** Bodies & Cavities
- TD** Technical Data

General Description

2 Way, Normally Closed, Proportional Flow Regulator Valve. Pressure Compensated. For additional information see Technical Tips on pages PV1-PV6.

Features

- One piece cartridge housing ensures internal concentricity
- Coil: Waterproof, hermetically sealed, requires no O’Rings; Symmetrical coil can be reversed without affecting performance.
- Nonmagnetic spool and housing assembly
- Factory-adjusted low variation option (Model “L”) is available for applications where low variation of flow from valve to valve is essential at a given current.

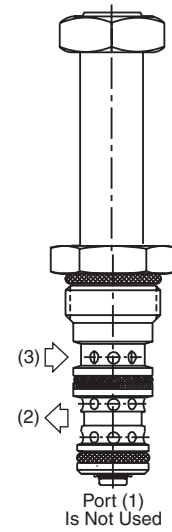
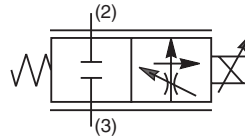

Specifications

Rated Flow	20	7.5 LPM (2 GPM) Low Flow ('SS' Coil)
	21	15 LPM (4 GPM) Standard ('SS' Coil)
	21	23 LPM (6 GPM) High Flow ('SP' Coil)
Maximum Input Pressure At Port 2	210 Bar (3000 PSI)	
Minimum Pressure Differential	20	6.9 Bar (150 PSI) Low Flow
	21	13.8 Bar (200 PSI) Standard
	21	20.7 Bar (300 PSI) High Flow
Maximum Internal Leakage	570 cc (35 cu. in.) @ 210 Bar (3000 PSI)	
Hysteresis @ 100 Hz PWM	<10% (Low Flow and Standard) <3% (High Flow)	
Cracking Pressure	25% of Input Signal	
Variation of Flow @ 35% of Rated Current	Standard Model Up To ±20% Of Rated Flow Model “L” ±7% Of Rated Flow	
Cartridge Material	All parts steel. All operating parts hardened steel.	
Operating Temp. Range/Seals	-40°C to +93.3°C (Nitrile) (-40°F to +200°F) -31.7°C to +121.1°C (Fluorocarbon) (-25°F to +250°F)	
Fluid Compatibility/ Viscosity	Mineral-based or synthetic with lubricating properties at viscosities of 45 to 2000 SSU (6 to 420 cSt)	
Filtration	ISO Code 16/13, SAE Class 4 or better	
Approx. Weight	.08 kg (.17 lbs.)	
Cavity	C08-3 (See BC Section for more details)	

Performance Curves

▲ PWM Current Regulator Recommended

Flow vs. Input Current

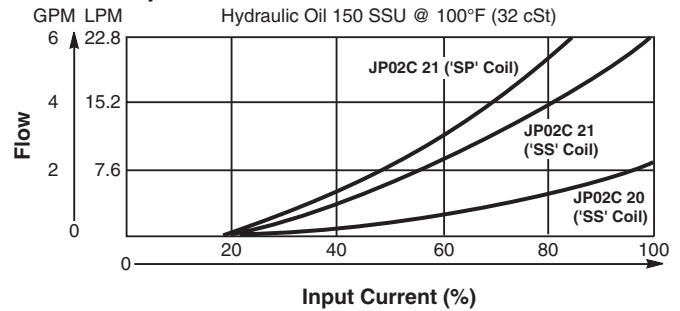

Flow Regulation (Measured 75% of Rated Current)

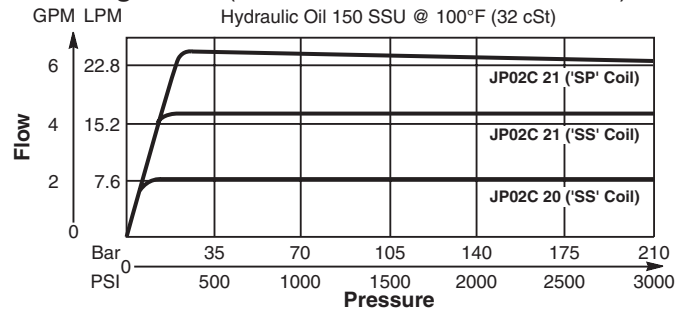

Pressure Drop vs. Flow

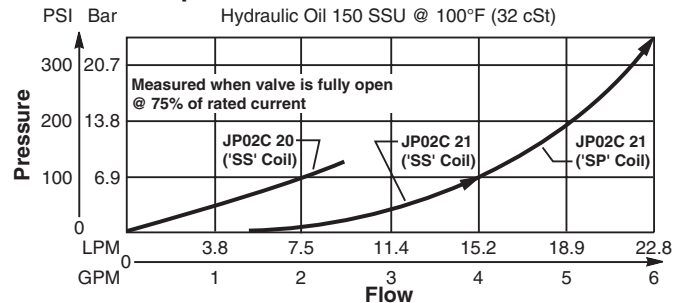

Dimensions Millimeters (Inches)

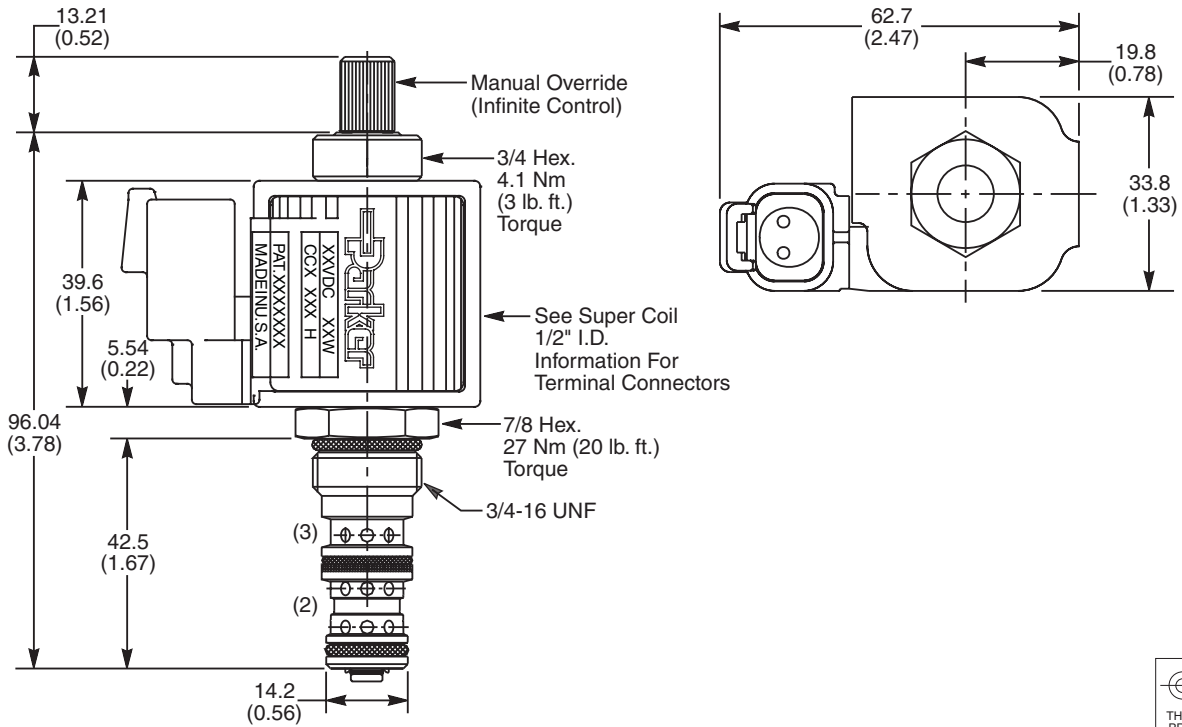

Ordering Information

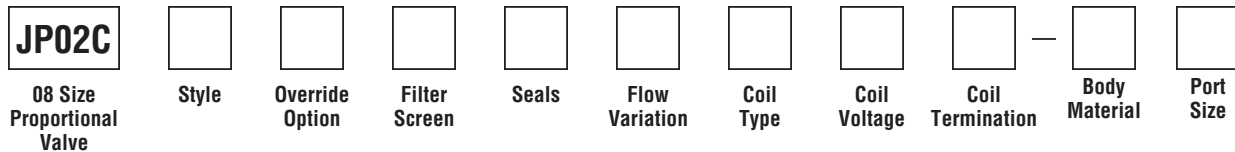

Code	Style (Maximum Regulated Flow)
20	Low Flow ('SS' Coil) 7.5 LPM (2 GPM)
21	Standard ('SS' Coil) 15 LPM (4 GPM)
21	High Flow ('SP' Coil) 23 LPM (6 GPM)

Code	Seals / Kit No.
N	Nitrile / Buna-N (Std.) (SK30105N-1)
V	Fluorocarbon / (SK30105V-1)

Code	Coil Voltage
Omit	Without Coil
D012	12 VDC
D024	24 VDC

Code	Body Material
Omit	Steel
A	Aluminum

Code	Override Option
0	Not Required
5	Detented M.O. (Infinite Control)

Code	Flow Variation
Omit	Standard Up to ±20% of Rated Flow
L	Low Variation (±7% of Rated Flow)

Code	Coil Termination
Omit	Without Coil
D	DIN Plug Face
A	Amp Jr. Timer*
L	Dual Lead Wire*
LS	Sealed Lead Wire*
H	Molded Deutsch*

Code	Port Size	Body Part No.
Omit	Cartridge Only	
4P	1/4" NPTF	(B08-3-*4P)
4T	SAE-4	(B08-3-*4T)
6T	SAE-6	(B08-3-*6T)
6B	3/8" BSPG	(B08-3-*6B)

Code	Filter Screen
0	Not Available
1	60 Mesh Screen on Port 2

Code	Coil Type
Omit	Without Coil
SS	Super Coil - 14 Watts
SP	Super Coil - 19 Watts

See Super Coil 1/2" I.D.
*DC Only

* Add "A" for aluminum, omit for steel.

Technical Information

- CV** Check Valves
- SH** Shuttle Valves
- LM** Load/Motor Controls
- FC** Flow Controls
- PC** Pressure Controls
- LE** Logic Elements
- DC** Directional Controls
- MV** Manual Valves
- SV** Solenoid Valves
- PV** Proportional Valves
- CE** Coils & Electronics
- BC** Bodies & Cavities
- TD** Technical Data

General Description

2 Way, Normally Closed, Proportional Flow Regulator Valve. Partially Pressure Compensated. For additional information see Technical Tips on pages PV1-PV6.

Features

- Analog Proportional Partially Pressure Compensated Flow Regulator regulates flow proportionally to the input solenoid current.
- A low cost valve designed to be used in applications where fine pressure compensation is not required.
- One piece cartridge housing ensures internal concentricity
- Coil: Waterproof, hermetically sealed, requires no O’Rings; Symmetrical coil can be reversed without affecting performance.
- Nonmagnetic spool and housing assembly
- Factory-adjusted low variation option (Model “L”) is available for applications where low variation of flow from valve to valve is essential at a given current or when an external pressure compensator is used.

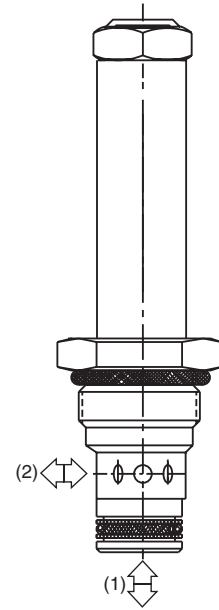
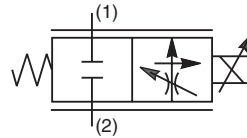

Specifications

Rated Flow 2 to 1 @ 210 Bar (3000 PSI)	Standard ('SS' Coil) 30 LPM (8 GPM) High Flow ('SP' Coil) 36 LPM (9.5 GPM)
Preferable Input Port For Best Hysteresis	Port 1
Hysteresis @ 100 Hz PWM	<10%
Cracking Pressure	21% of Rated Current (Standard) 17% of Rated Current (High Flow)
Variation of Flow @ 35% of Rated Current & Constant Pressure Compensator	Standard Model Up To ±5% Of Rated Flow Model "L" ±2% Of Rated Flow
Cartridge Material	All parts steel. All operating parts hardened steel.
Operating Temp. Range/Seals	-40°C to +93.3°C (Nitrile) (-40°F to +200°F) -31.7°C to +121.1°C (Fluorocarbon) (-25°F to +250°F)
Fluid Compatibility/ Viscosity	Mineral-based or synthetic with lubricating properties at viscosities of 45 to 2000 SSU (6 to 420 cSt)
Filtration	ISO Code 16/13, SAE Class 4 or better
Approx. Weight	.12 kg (.26 lbs.)
Cavity	C10-2 (See BC Section for more details)

Performance Curves

▲ PWM Current Regulator Recommended

Flow vs. Input Current

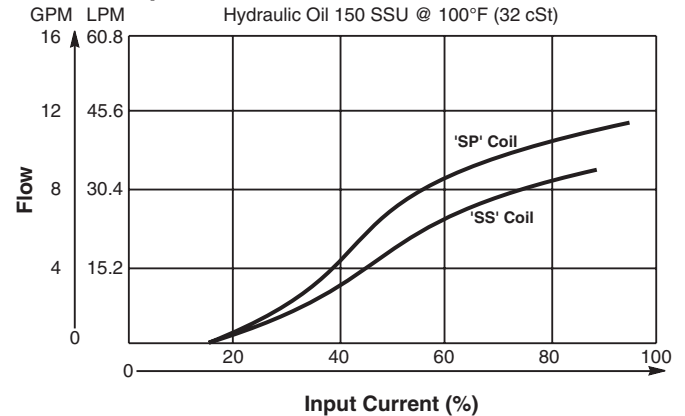

Flow Regulation

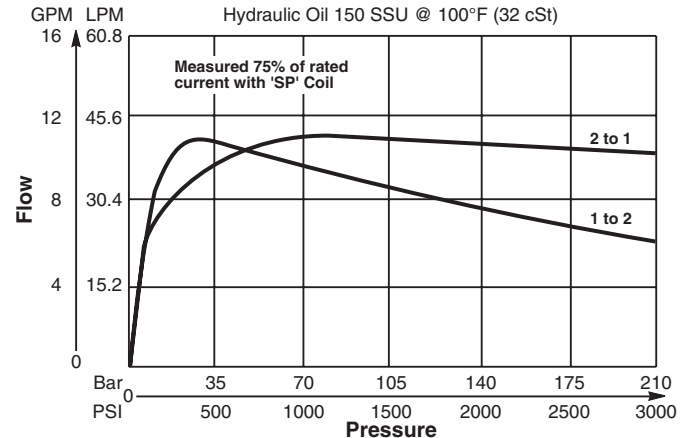

Dimensions Millimeters (Inches)

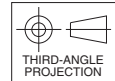
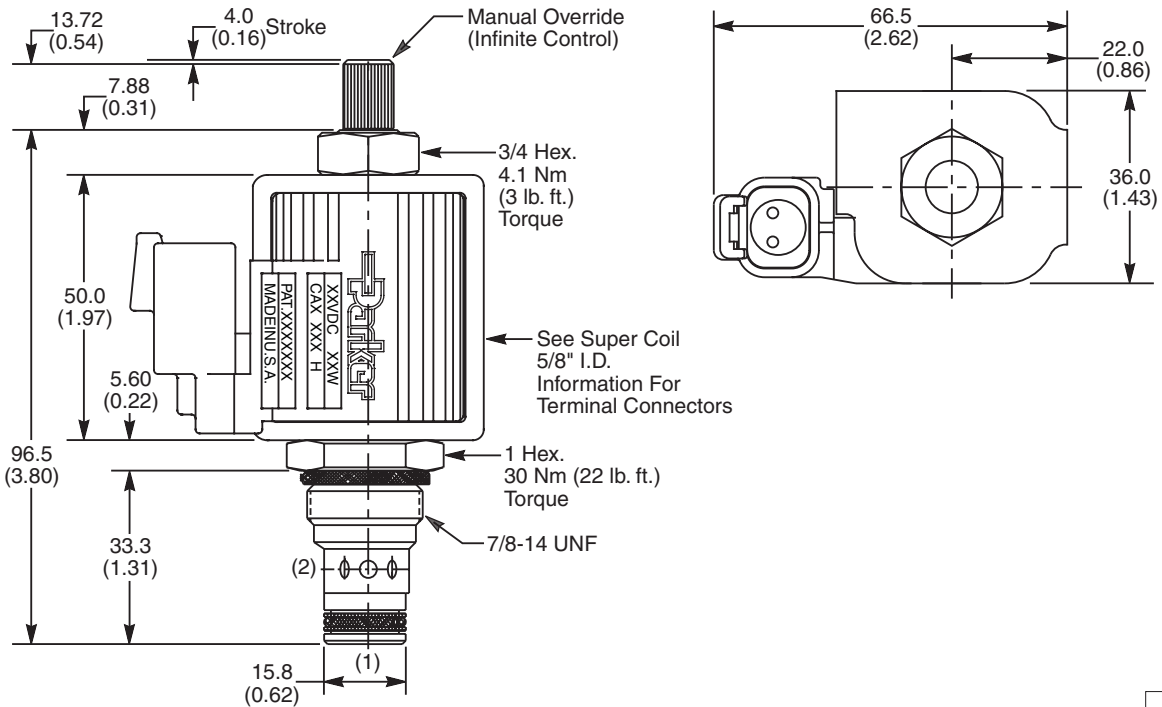

Ordering Information

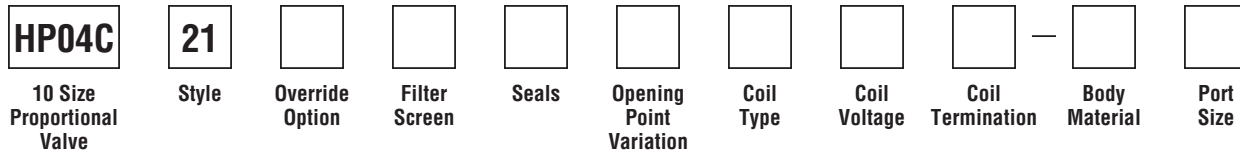

Code	Style (Maximum Regulated Flow)
21	Standard ('SS' Coil) 30 LPM (8 GPM)
21	High Flow ('SP' Coil) 36 LPM (9.5 GPM)

Code	Seals / Kit No.
N	Nitrile / Buna-N (Std.) (SK30503N-1)
V	Fluorocarbon / (SK30503V-1)

Code	Coil Voltage
Omit	Without Coil
D012	12 VDC
D024	24 VDC

Code	Body Material
Omit	Steel
A	Aluminum

Code	Override Option
0	Not Required
5	Detented M.O. (Infinite Control)

Code	Flow Variation
Omit	Standard Up to ±5% of Current
L	Low Variation (±2% of Current Flow)

Code	Coil Termination
Omit	Without Coil
D	DIN Plug Face
A	Amp Jr. Timer*
L	Dual Lead Wire*
LS	Sealed Lead Wire*
H	Molded Deutsch*

Code	Port Size	Body Part No.
Omit	Cartridge Only	
4P	1/4" NPTF	(B10-2-*4P)
6P	3/8" NPTF	(B10-2-*6P)
8P	1/2" NPTF	(B10-2-*8P)
6T	SAE-6	(B10-2-*6T)
8T	SAE-8	(B10-2-*8T)
T8T	SAE-8	(B10-2-T8T)†
6B	3/8" BSPG	(B10-2-*6B)

Code	Filter Screen
0	Not Available

Code	Coil Type
Omit	Without Coil
SS	Super Coil - 18 Watts
SP	Super Coil - 28 Watts

See Super Coil 5/8" I.D.
*DC Only

* Add "A" for aluminum, omit for steel.
† Steel body only.

- CV
- Check Valves
- SH
- Shuttle Valves
- LM
- Load/Motor Controls
- FC
- Flow Controls
- PC
- Pressure Controls
- LE
- Logic Elements
- DC
- Directional Controls
- MV
- Manual Valves
- SV
- Solenoid Valves
- PV
- Proportional Valves
- CE
- Coils & Electronics
- BC
- Bodies & Cavities
- TD
- Technical Data

Technical Information

- CV** Check Valves
- SH** Shuttle Valves
- LM** Load/Motor Controls
- FC** Flow Controls
- PC** Pressure Controls
- LE** Logic Elements
- DC** Directional Controls
- MV** Manual Valves
- SV** Solenoid Valves
- PV** Proportional Valves
- CE** Coils & Electronics
- BC** Bodies & Cavities
- TD** Technical Data

General Description

2 Way, Normally Closed, Proportional Flow Regulator Valve. Pressure Compensated. For additional information see Technical Tips on pages PV1-PV6.

Features

- One piece cartridge housing ensures internal concentricity
- Coil: Waterproof, hermetically sealed, requires no O’Rings; Symmetrical coil can be reversed without affecting performance.
- Nonmagnetic spool and housing assembly
- Factory-adjusted low variation option (Model “L”) is available for applications where low variation of flow from valve to valve is essential at a given current.

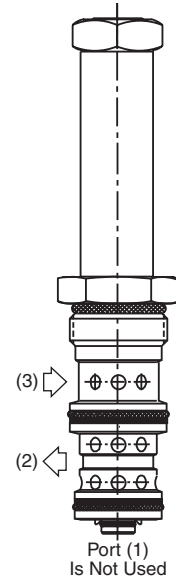
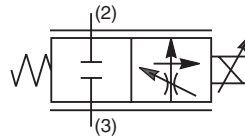

Specifications

Rated Flow	21	30 LPM (8 GPM) Standard ('SS' Coil)
	21	36 LPM (9.5 GPM) High Flow ('SP' Coil)
Maximum Input Pressure At Port 2	210 Bar (3000 PSI)	
Minimum Pressure Differential	21	13.8 Bar (200 PSI) Standard
	21	20.7 Bar (300 PSI) High Flow
Maximum Internal Leakage	780 cc (46 cu. in.) @ 210 Bar (3000 PSI)	
Hysteresis @ 100 Hz PWM	7%	
Cracking Pressure	25% of Input Signal	
Variation of Flow @ 35% of Rated Current	Standard Model Up To ±20% Of Rated Flow	
	Model "L" ±7% Of Rated Flow	
Cartridge Material	All parts steel. All operating parts hardened steel.	
Operating Temp. Range/Seals	-40°C to +93.3°C (Nitrile) (-40°F to +200°F) -31.7°C to +121.1°C (Fluorocarbon) (-25°F to +250°F)	
Fluid Compatibility/ Viscosity	Mineral-based or synthetic with lubricating properties at viscosities of 45 to 2000 SSU (6 to 420 cSt)	
Filtration	ISO Code 16/13, SAE Class 4 or better	
Approx. Weight	.13 kg (.28 lbs.)	
Cavity	3X (See BC Section for more details)	

Performance Curves

▲ PWM Current Regulator Recommended

Flow vs. Input Signal

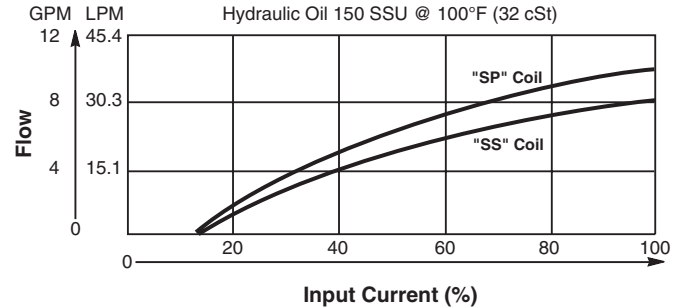

Flow Regulation (Measured 75% of Rated Current)

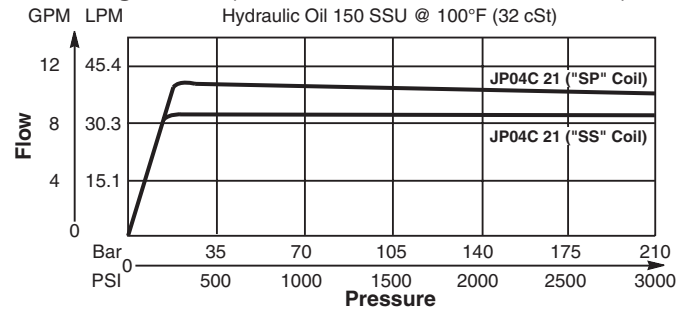

Pressure Drop vs. Flow

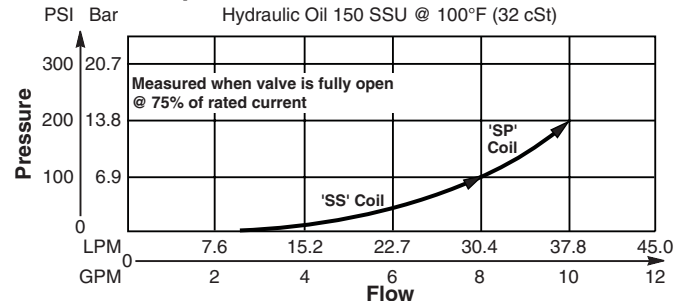

Dimensions Millimeters (Inches)

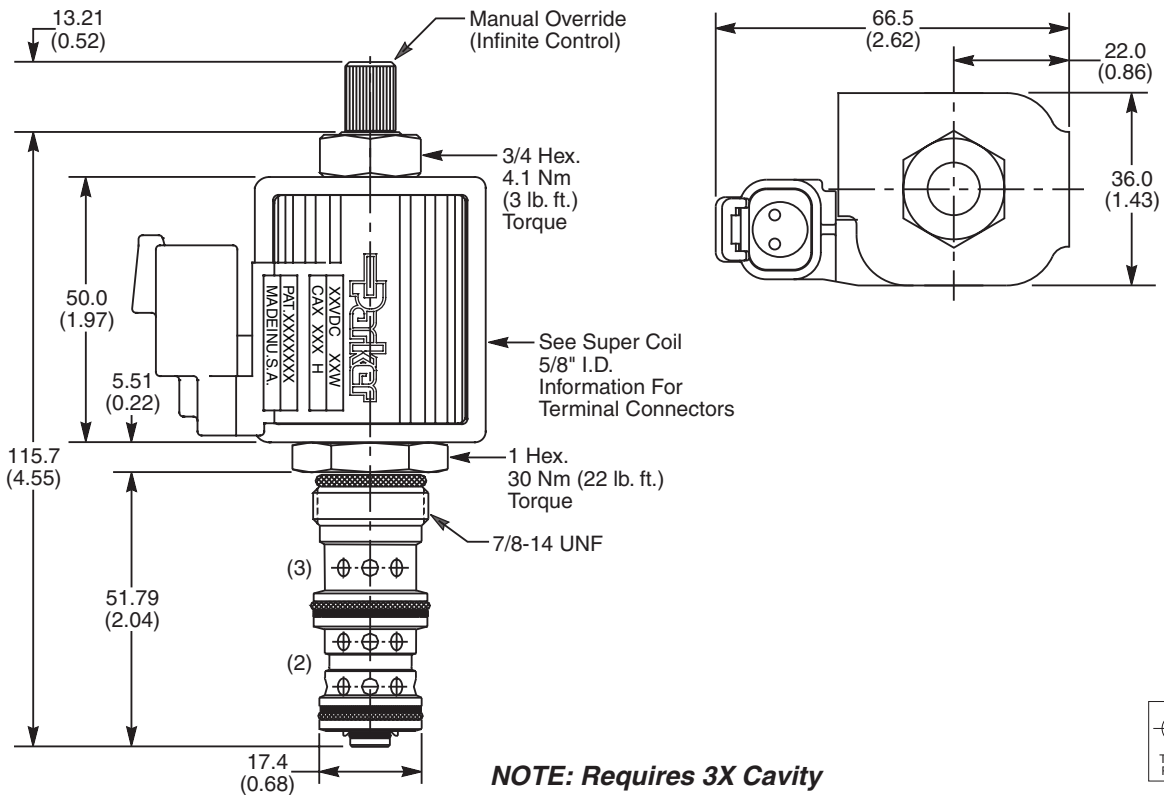

NOTE: Requires 3X Cavity

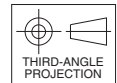

Ordering Information

JP04C **21**

10 Size Proportional Valve Style Override Option Filter Screen Seals Flow Variation Coil Type Coil Voltage Coil Termination

Code	Style (Maximum Regulated Flow)
21	Standard ('SS' Coil) 30 LPM (8 GPM)
21	High Flow ('SP' Coil) 36 LPM 9.5 GPM)

Code	Filter Screen
0	Not Required
1	60 Mesh Screen on Port 2

Code	Flow Variation
Omit	Standard Up to ±20% of Rated Flow
L	Low Variation (±7% of Rated Flow)

Code	Coil Voltage
Omit	Without Coil
D012	12 VDC
D024	24 VDC

Code	Override Option
0	Not Required
5	Detented M.O. (Infinite Control)

Code	Seals / Kit No.
N	Nitrile / Buna-N (Std.) (SK30106N-1)
V	Fluorocarbon / (SK30106V-1)

Code	Coil Type
Omit	Without Coil
SS	Super Coil - 18 Watts
SP	Super Coil - 28 Watts

Code	Coil Termination
Omit	Without Coil
D	DIN Plug Face
A	Amp Jr. Timer*
L	Dual Lead Wire*
LS	Sealed Lead Wire*
H	Molded Deutsch*

See Super Coil 5/8" I.D.
 *DC Only

Order Bodies Separately

LB10

Line Body Porting Body Material

Code	Porting
553	1/2" SAE
554	3/8" BSP

Code	Body Material
A	Aluminum
S	Steel



- CV**
- Check Valves
- SH**
- Shuttle Valves
- LM**
- Load/Motor Controls
- FC**
- Flow Controls
- PC**
- Pressure Controls
- LE**
- Logic Elements
- DC**
- Directional Controls
- MV**
- Manual Valves
- SV**
- Solenoid Valves
- PV**
- Proportional Valves
- CE**
- Coils & Electronics
- BC**
- Bodies & Cavities
- TD**
- Technical Data

Technical Information

- CV** Check Valves
- SH** Shuttle Valves
- LM** Load/Motor Controls
- FC** Flow Controls
- PC** Pressure Controls
- LE** Logic Elements
- DC** Directional Controls
- MV** Manual Valves
- SV** Solenoid Valves
- PV** Proportional Valves
- CE** Coils & Electronics
- BC** Bodies & Cavities
- TD** Technical Data

General Description

2 Way, Normally Closed, Proportional Flow Regulator Valve. Pressure Compensated. For additional information see Technical Tips on pages PV1-PV6.

Features

- One piece cartridge housing ensures internal concentricity
- Coil: Waterproof, hermetically sealed, requires no O'Rings; Symmetrical coil can be reversed without affecting performance.

NOTE:

This valve will be available January 1, 2011.

Specifications

Rated Flow @ 75% of Rated Current	56.8 LPM (15 GPM) Requires ('SP' Coil)
Maximum Input Pressure At Port 2	210 Bar (3000 PSI)
Minimum Pressure Differential	20.7 Bar (300 PSI)
Maximum Internal Leakage	568 cc (35 cu. in.) @ 210 Bar (3000 PSI)
Hysteresis @ 100 Hz PWM	>15%
Cartridge Material	All parts steel. All operating parts hardened steel.
Operating Temp. Range/Seals	-40°C to +93.3°C (Nitrile) (-40°F to +200°F) -31.7°C to +121.1°C (Fluorocarbon) (-25°F to +250°F)
Fluid Compatibility/ Viscosity	Mineral-based or synthetic with lubricating properties at viscosities of 45 to 2000 SSU (6 to 420 cSt)
Filtration	ISO Code 16/13, SAE Class 4 or better
Approx. Weight	.40 kg (.89 lbs.)
Cavity	C12-3L (See BC Section for more details)

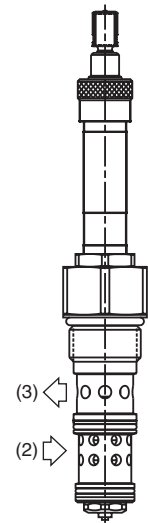
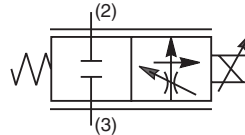

Port (1) Is Not Used

Performance Curves

▲ PWM Current Regulator Recommended

Pressure Compensation of Regulated Flow

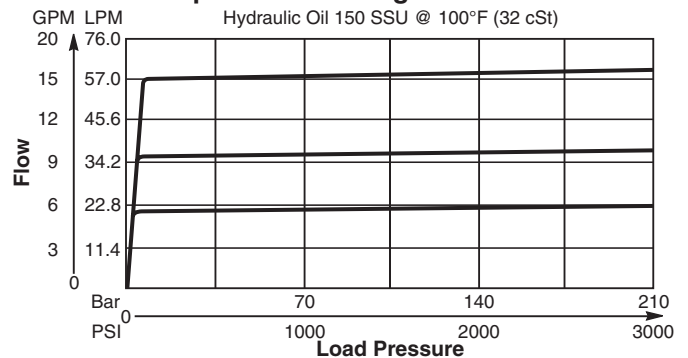

Flow vs. Input Current

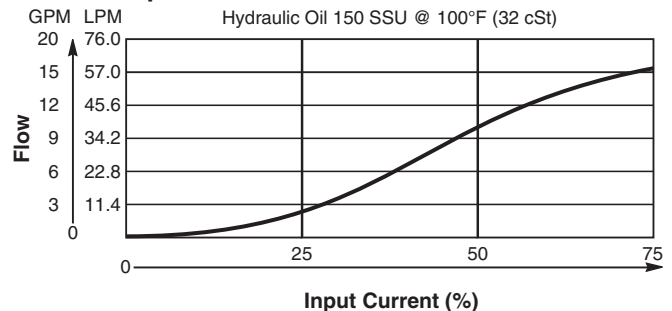

Pressure Drop vs. Flow (Through cartridge only)

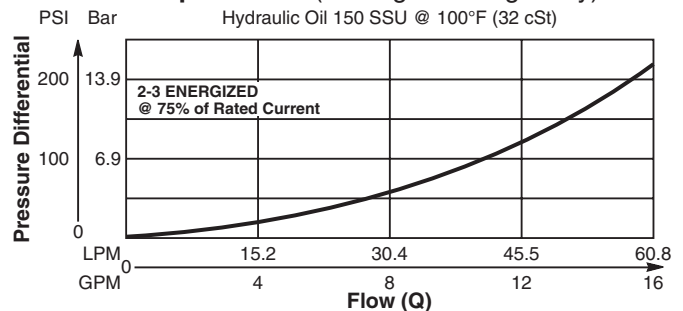

Dimensions Millimeters (Inches)

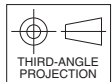
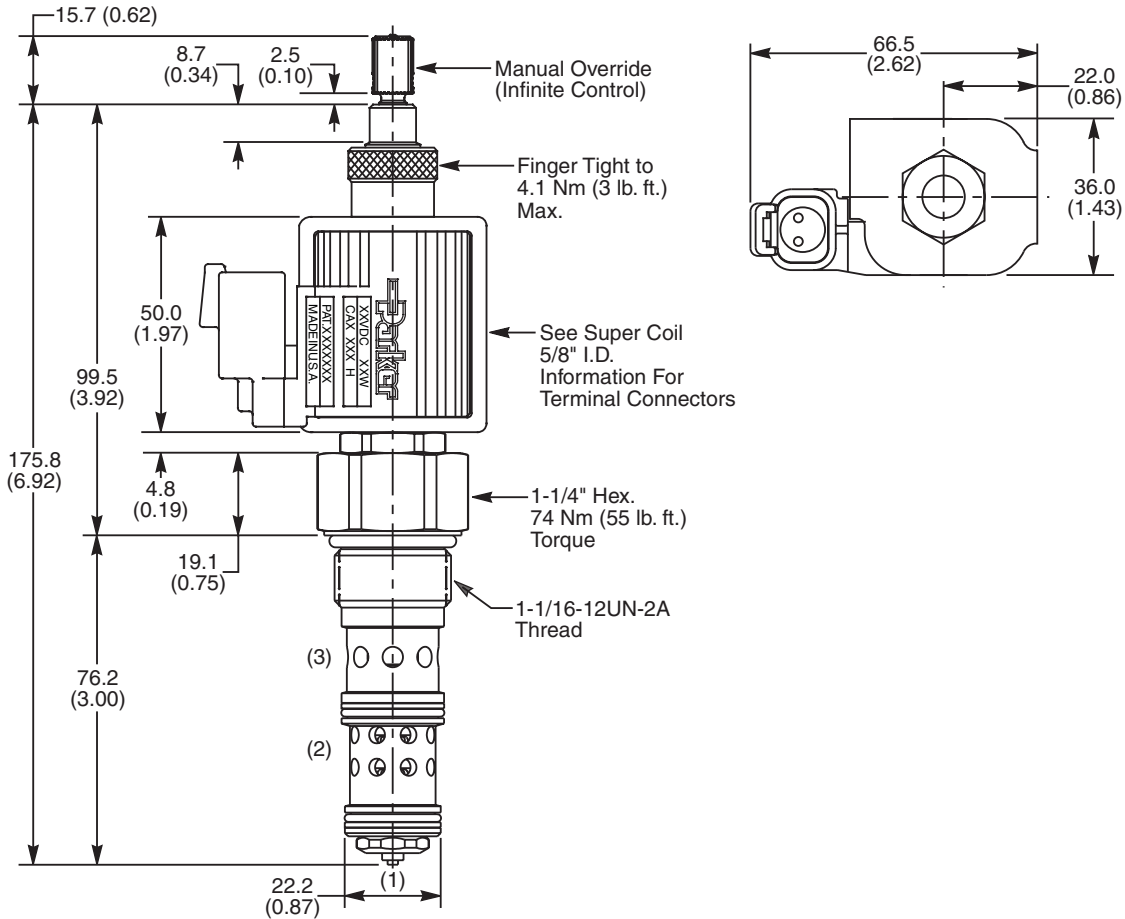

Ordering Information

DFA125C	21	S				
12 Size Proportional Valve	Style	Override Option	Seals	Coil Type	Coil Voltage	Coil Termination

NOTE:
*This valve will be available
January 1, 2011.*

Code	Style (Maximum Regulated Flow)
21	High Flow ('SP' Coil) 56.8 LPM (15 GPM)

Code	Seals / Kit No.
N	Nitrile / Buna-N (Std.) (SK12-3LN)
V	Fluorocarbon / (SK12-3LV)

Code	Coil Type
Omit	Without Coil
SP	Super Coil - 28 Watts

Code	Coil Termination
Omit	Without Coil
D	DIN Plug Face
A	Amp Jr. Timer*
S	Dual Spade*
L	Dual Lead Wire*
LS	Sealed Lead Wire*
H	Molded Deutsch*

Code	Override Option
Omit	Not Available
S	Standard M.O. (Infinite Control)

Code	Coil Voltage
Omit	Without Coil
D012	12 VDC
D024	24 VDC

*See Super Coil 5/8" I.D.
DC Only

Order Bodies Separately

B12	3L	A	12T
12 Size	3-Way Long Cavity	Body Material	Port Size

Code	Body Material
A	Aluminum

Code	Port Size
12T	SAE - 12

CV

Check
Valves

SH

Shuttle
Valves

LM

Load/Motor
Controls

FC

Flow
Controls

PC

Pressure
Controls

LE

Logic
Elements

DC

Directional
Controls

MV

Manual
Valves

SV

Solenoid
Valves

PV

Proportional
Valves

CE

Coils &
Electronics

BC

Bodies &
Cavities

TD

Technical
Data

Technical Information

- CV** Check Valves
- SH** Shuttle Valves
- LM** Load/Motor Controls
- FC** Flow Controls
- PC** Pressure Controls
- LE** Logic Elements
- DC** Directional Controls
- MV** Manual Valves
- SV** Solenoid Valves
- PV** Proportional Valves
- CE** Coils & Electronics
- BC** Bodies & Cavities
- TD** Technical Data

General Description

2 Way, Normally Open, Proportional Flow Regulator Valve. Partially Pressure Compensated. For additional information see Technical Tips on pages PV1-PV6.

Features

- Analog Proportional Partially Pressure Compensated Flow Regulator regulates flow proportionally to the input solenoid current
- The valve is designed to be used in applications where fine pressure compensation is not required and an economical solution is important
- One piece cartridge housing ensures internal concentricity
- Coil: Waterproof, hermetically sealed, requires no O’Rings; Symmetrical coil can be reversed without affecting performance.
- Nonmagnetic spool and housing assembly
- Factory-adjusted low variation option (Model “L”) is available for applications where low variation of flow from valve to valve is essential at a given current or when an external pressure compensator is used.

Specifications

Rated Flow @ 210 Bar (3000 PSI)	2 to 1 19 LPM (5 GPM)
Preferable Input Port For Best Hysteresis	Port 1
Hysteresis @ 100 Hz PWM	<10%
Variation of Flow @ 35% of Rated Current & Constant ΔP Maintained By Pressure Compensator	Standard Model Up To ±20% Of Rated Flow Model “L” ±7% Of Rated Flow
Cartridge Material	All parts steel. All operating parts hardened steel.
Operating Temp. Range/Seals	-40°C to +93.3°C (Nitrile) (-40°F to +200°F) -31.7°C to +121.1°C (Fluorocarbon) (-25°F to +250°F)
Fluid Compatibility/ Viscosity	Mineral-based or synthetic with lubricating properties at viscosities of 45 to 2000 SSU (6 to 420 cSt)
Filtration	ISO Code 16/13, SAE Class 4 or better
Approx. Weight	.08 kg (.17 lbs.)
Cavity	2X (See BC Section for more details)

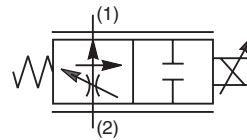
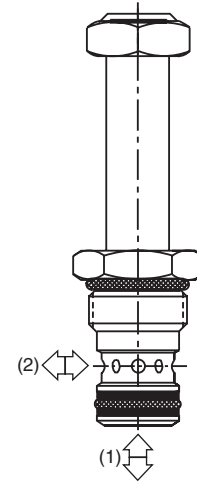

Performance Curves

▲ PWM Current Regulator Recommended

Flow vs. Input Current

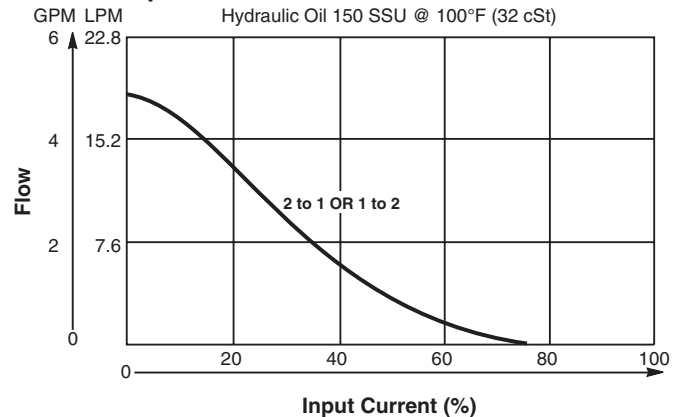

Flow Regulation (Measured at De-Energized Coil)

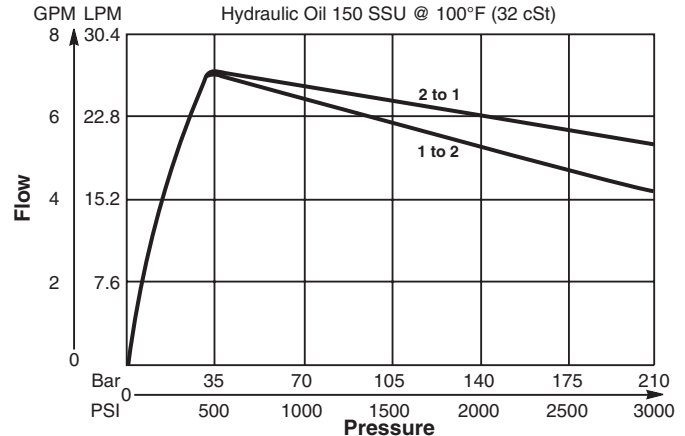

Dimensions Millimeters (Inches)

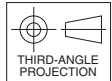
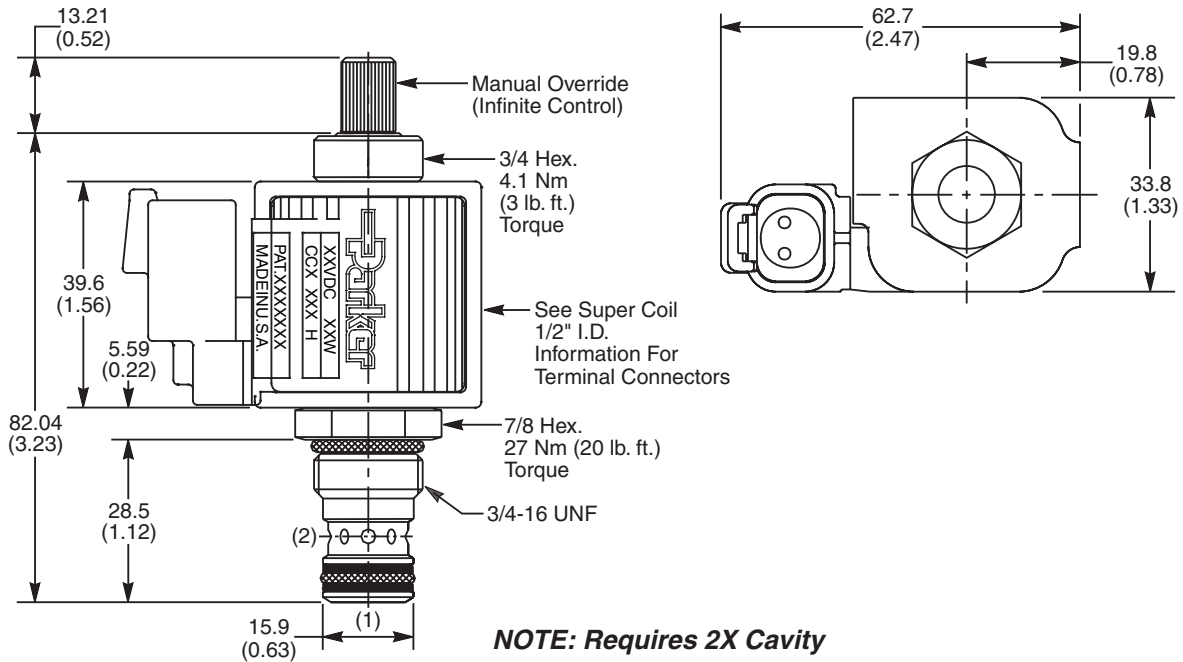

Ordering Information

HP02P **21**

08 Size Proportional Valve **Style** **Override Option** **Filter Screen** **Seals** **Flow Variation** **Coil Type** **Coil Voltage** **Coil Termination**

Code	Style (Maximum Regulated Flow)
21	High Flow ('SP' Coil) 19 LPM (5 GPM)

Code	Filter Screen
0	Not Available

Code	Flow Variation
Omit	Standard Up to ±20% of Rated Flow
L	Low Variation (±7% of Rated Flow)

Code	Coil Voltage
Omit	Without Coil
D012	12 VDC
D024	24 VDC

Code	Override Option
0	Not Required
5	Detented M.O. (Infinite Control)

Code	Seals / Kit No.
N	Nitrile / Buna-N (Std.) (SK30076N-1)
V	Fluorocarbon / (SK30076V-1)

Code	Coil Type
Omit	Without Coil
SP	Super Coil - 19 Watts

Code	Coil Termination
Omit	Without Coil
D	DIN Plug Face
A	Amp Jr. Timer*
L	Dual Lead Wire*
LS	Sealed Lead Wire*
H	Molded Deutsch*

See Super Coil 1/2" I.D.
*DC Only

Order Bodies Separately

LB10

Line Body **Porting** **Body Material**

Code	Porting
513	3/8" SAE
515	1/4" BSP

Code	Body Material
A	Aluminum
S	Steel



- CV**
Check Valves
- SH**
Shuttle Valves
- LM**
Load/Motor Controls
- FC**
Flow Controls
- PC**
Pressure Controls
- LE**
Logic Elements
- DC**
Directional Controls
- MV**
Manual Valves
- SV**
Solenoid Valves
- PV**
Proportional Valves
- CE**
Coils & Electronics
- BC**
Bodies & Cavities
- TD**
Technical Data

Technical Information

- CV** Check Valves
- SH** Shuttle Valves
- LM** Load/Motor Controls
- FC** Flow Controls
- PC** Pressure Controls
- LE** Logic Elements
- DC** Directional Controls
- MV** Manual Valves
- SV** Solenoid Valves
- PV** Proportional Valves
- CE** Coils & Electronics
- BC** Bodies & Cavities
- TD** Technical Data

General Description

2 Way, Normally Open, Proportional Flow Regulator Valve. Pressure Compensated. For additional information see Technical Tips on pages PV1-PV6.

Features

- One piece cartridge housing ensures internal concentricity
- Coil: Waterproof, hermetically sealed, requires no O’Rings; Symmetrical coil can be reversed without affecting performance.
- Nonmagnetic spool and housing assembly
- Factory-adjusted low variation option (Model “L”) is available for applications where low variation of flow from valve to valve is essential at a given current.

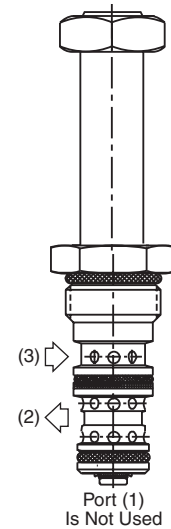
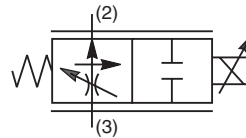

Specifications

Rated Flow	20	9.5 LPM (2.5 GPM) Standard (‘SS’ Coil)
	21	19 LPM (5 GPM) High Flow (‘SP’ Coil)
Maximum Input Pressure At Port 2	210 Bar (3000 PSI)	
Minimum Pressure Differential	20	6.9 Bar (150 PSI) Standard
	21	20.7 Bar (300 PSI) High Flow
Maximum Internal Leakage	570 cc (35 cu. in.) @ 210 Bar (3000 PSI)	
Hysteresis @ 100 Hz PWM	<3%	
Variation of Flow @ 35% of Rated Current	Standard Model Up To ±20% Of Rated Flow Model “L” ±7% Of Rated Flow	
Cartridge Material	All parts steel. All operating parts hardened steel.	
Operating Temp. Range/Seals	-40°C to +93.3°C (Nitrile) (-40°F to +200°F) -31.7°C to +121.1°C (Fluorocarbon) (-25°F to +250°F)	
Fluid Compatibility/ Viscosity	Mineral-based or synthetic with lubricating properties at viscosities of 45 to 2000 SSU (6 to 420 cSt)	
Filtration	ISO Code 16/13, SAE Class 4 or better	
Approx. Weight	.08 kg (.17 lbs.)	
Cavity	C08-3 (See BC Section for more details)	

Performance Curves

▲ PWM Current Regulator Recommended

Flow vs. Input Current

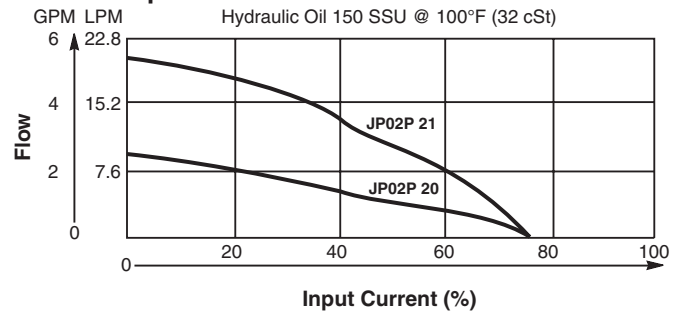

Flow Regulation (Measured 75% of Rated Current)

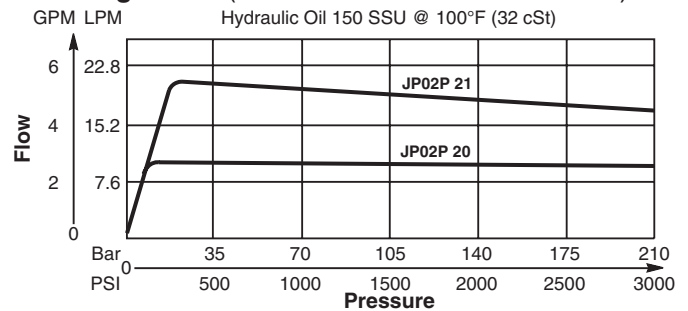

Pressure Drop vs. Flow

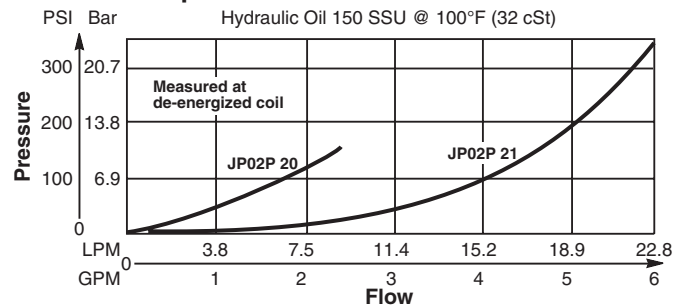

Dimensions Millimeters (Inches)

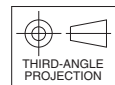
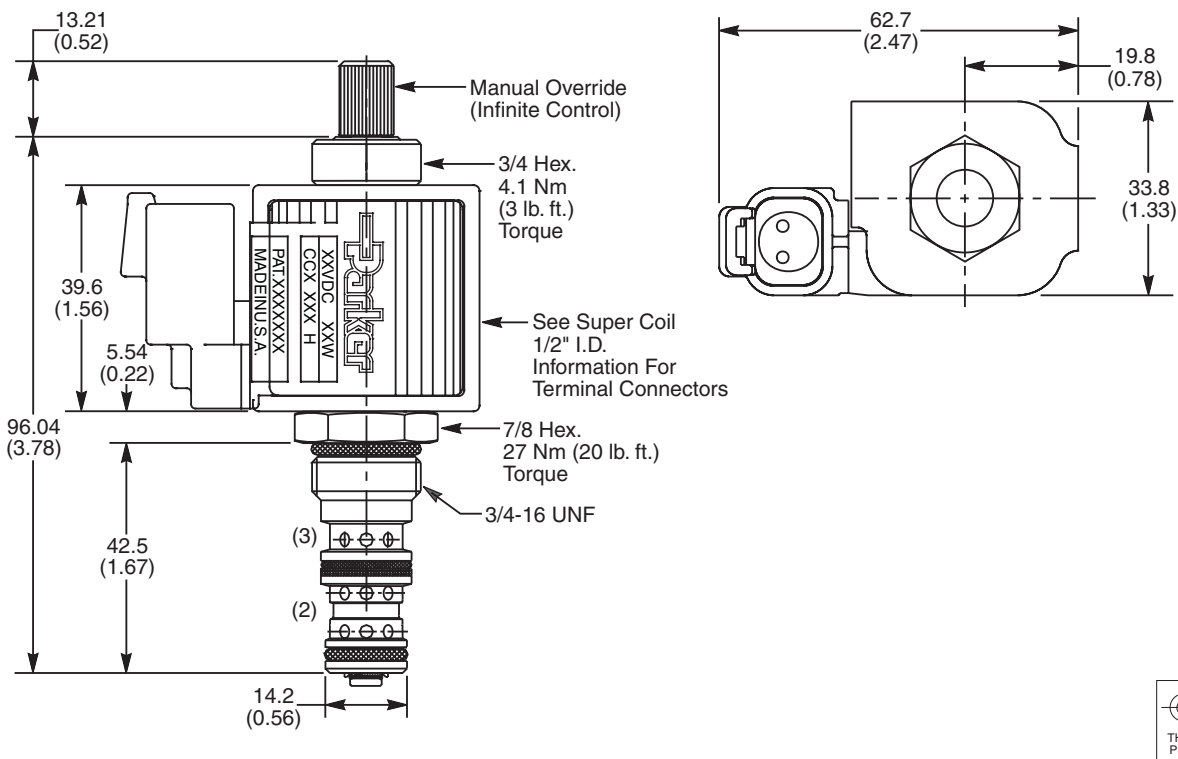

Ordering Information

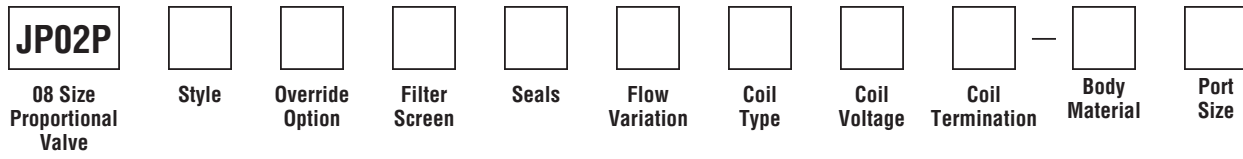

Code	Style (Maximum Regulated Flow)	Code	Seals / Kit No.	Code	Coil Voltage	Code	Body Material		
20	Standard ('SS' Coil) 9.5 LPM (2.5 GPM)	N	Nitrile / Buna-N (Std.) (SK30105N-1)	Omit	Without Coil	Omit	Steel		
21	High Flow ('SP' Coil) 19 LPM (5 GPM)	V	Fluorocarbon / (SK30105V-1)	D012	12 VDC	A	Aluminum		
				D024	24 VDC				
Code	Override Option	Code	Flow Variation	Code	Coil Termination	Code	Port Size	Code	Body Part No.
0	Not Required	Omit	Standard Up to ±20% of Rated Flow	Omit	Without Coil	Omit	Cartridge Only	4P	1/4" NPTF (B08-3-*4P)
5	Detented M.O. (Infinite Control)	L	Low Variation (±7% of Rated Flow)	D	DIN Plug Face	4T	SAE-4 (B08-3-*4T)	6T	SAE-6 (B08-3-*6T)
Code	Filter Screen	Code	Coil Type	L	Dual Lead Wire*	6B	3/8" BSPG (B08-3-*6B)		
0	Not Required	Omit	Without Coil	LS	Sealed Lead Wire*				
1	60 Mesh Screen on Port 2	SS	Super Coil - 14 Watts	H	Molded Deutsch*				
		SP	Super Coil - 19 Watts						

See Super Coil 1/2" I.D.
 *DC Only

* Add "A" for aluminum, omit for steel.



- CV Check Valves
- SH Shuttle Valves
- LM Load/Motor Controls
- FC Flow Controls
- PC Pressure Controls
- LE Logic Elements
- DC Directional Controls
- MV Manual Valves
- SV Solenoid Valves
- PV Proportional Valves
- CE Coils & Electronics
- BC Bodies & Cavities
- TD Technical Data

Technical Information

- CV** Check Valves
- SH** Shuttle Valves
- LM** Load/Motor Controls
- FC** Flow Controls
- PC** Pressure Controls
- LE** Logic Elements
- DC** Directional Controls
- MV** Manual Valves
- SV** Solenoid Valves
- PV** Proportional Valves
- CE** Coils & Electronics
- BC** Bodies & Cavities
- TD** Technical Data

General Description

2 Way, Normally Open, Proportional Flow Regulator Valve. Partially Pressure Compensated. For additional information see Technical Tips on pages PV1-PV6.

Features

- Analog Proportional Partially Pressure Compensated Flow Regulator regulates flow proportionally to the input solenoid current
- The valve is designed to be used in applications where fine pressure compensation is not required and an economical solution is important
- One piece cartridge housing ensures internal concentricity
- Coil: Waterproof, hermetically sealed, requires no O’Rings; Symmetrical coil can be reversed without affecting performance.
- Nonmagnetic spool and housing assembly
- Factory-adjusted low variation option (Model “L”) is available for applications where low variation of flow from valve to valve is essential at a given current or when an external pressure compensator is used.

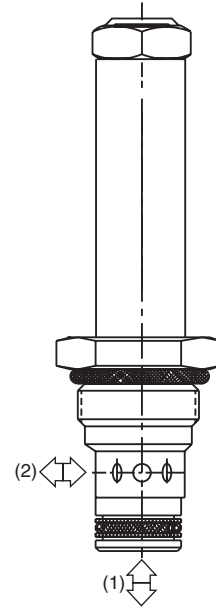
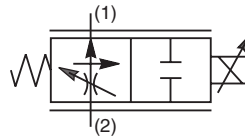

Specifications

Rated Flow @ 210 Bar (3000 PSI)	23 LPM (6 GPM)
Hysteresis @ 100 Hz PWM	<10%
Closing Point	65% of Rated Current
Variation of Closing Point	Standard Model Up To ±5% Of Rated Current Model “L” ±2% Of Rated Current
Cartridge Material	All parts steel. All operating parts hardened steel.
Operating Temp. Range/Seals	-40°C to +93.3°C (Nitrile) (-40°F to +200°F) -31.7°C to +121.1°C (Fluorocarbon) (-25°F to +250°F)
Fluid Compatibility/ Viscosity	Mineral-based or synthetic with lubricating properties at viscosities of 45 to 2000 SSU (6 to 420 cSt)
Filtration	ISO Code 16/13, SAE Class 4 or better
Approx. Weight	.12 kg (.26 lbs.)
Cavity	C10-2 (See BC Section for more details)

Performance Curves

▲ PWM Current Regulator Recommended

Flow vs. Input Current

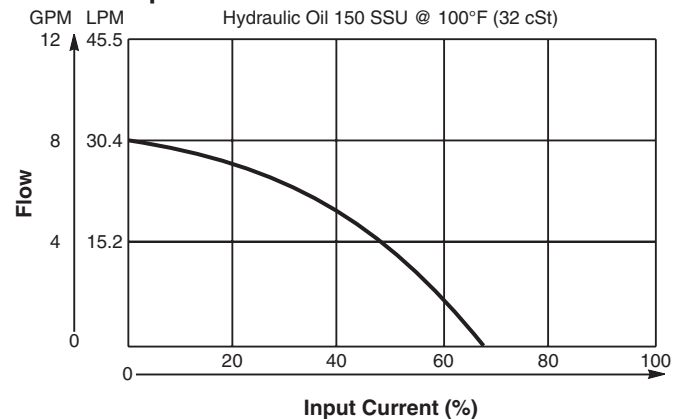

Flow Regulation

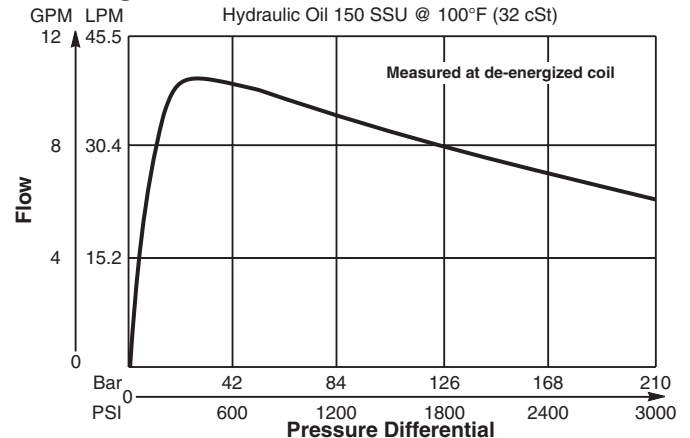

Dimensions Millimeters (Inches)

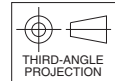
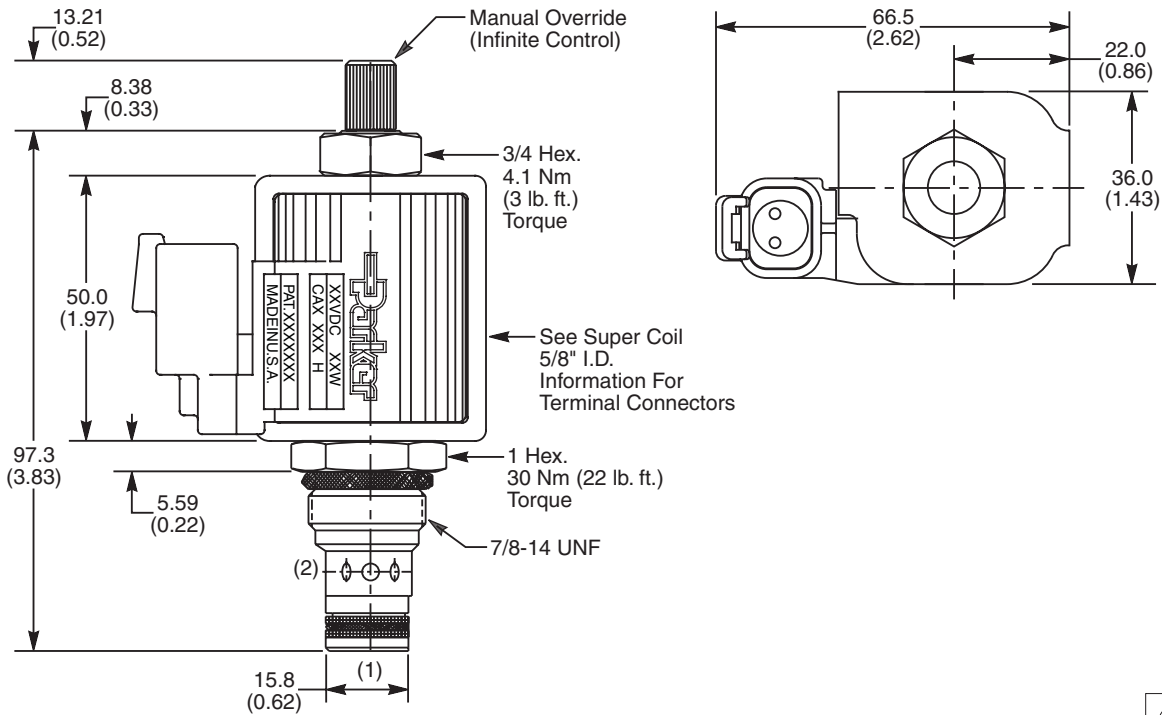

Ordering Information

HP04P	21									
10 Size Proportional Valve	Style	Override Option	Filter Screen	Seals	Opening Point Variation	Coil Type	Coil Voltage	Coil Termination	Body Material	Port Size

Code	Style (Maximum Regulated Flow)
21	High Flow ("SP" Coil) 30 LPM (8 GPM)

Code	Seals / Kit No.
N	Nitrile / Buna-N (Std.) (SK30503N-1)
V	Fluorocarbon / (SK30503V-1)

Code	Coil Voltage
Omit	Without Coil
D012	12 VDC
D024	24 VDC

Code	Body Material
Omit	Steel
A	Aluminum

Code	Override Option
0	Not Required
5	Detented M.O. (Infinite Control)

Code	Flow Variation
Omit	Standard Up to ±5% of Current Flow
L	Low Variation (±2% of Current Flow)

Code	Coil Termination
Omit	Without Coil
D	DIN Plug Face
A	Amp Jr. Timer*
L	Dual Lead Wire*
LS	Sealed Lead Wire*
H	Molded Deutsch*

Code	Port Size	Body Part No.
Omit	Cartridge Only	
4P	1/4" NPTF	(B10-2-*4P)
6P	3/8" NPTF	(B10-2-*6P)
8P	1/2" NPTF	(B10-2-*8P)
6T	SAE-6	(B10-2-*6T)
8T	SAE-8	(B10-2-*8T)
T8T	SAE-8	(B10-2-T8T)†
6B	3/8" BSPG	(B10-2-*6B)

Code	Filter Screen
0	Not Available

Code	Coil Type
Omit	Without Coil
SP	Super Coil - 28 Watts

See Super Coil 5/8" I.D.
*DC Only

* Add "A" for aluminum, omit for steel.
† Steel body only.

- CV
- Check Valves
- SH
- Shuttle Valves
- LM
- Load/Motor Controls
- FC
- Flow Controls
- PC
- Pressure Controls
- LE
- Logic Elements
- DC
- Directional Controls
- MV
- Manual Valves
- SV
- Solenoid Valves
- PV
- Proportional Valves
- CE
- Coils & Electronics
- BC
- Bodies & Cavities
- TD
- Technical Data

Technical Information

- CV** Check Valves
- SH** Shuttle Valves
- LM** Load/Motor Controls
- FC** Flow Controls
- PC** Pressure Controls
- LE** Logic Elements
- DC** Directional Controls
- MV** Manual Valves
- SV** Solenoid Valves
- PV** Proportional Valves
- CE** Coils & Electronics
- BC** Bodies & Cavities
- TD** Technical Data

General Description

2 Way, Normally Open, Proportional Flow Regulator Valve. Pressure Compensated. For additional information see Technical Tips on pages PV1-PV6.

Features

- One piece cartridge housing ensures internal concentricity
- Coil: Waterproof, hermetically sealed, requires no O’Rings; Symmetrical coil can be reversed without affecting performance.
- Nonmagnetic spool and housing assembly
- Factory-adjusted low variation option (Model “L”) is available for applications where low variation of flow from valve to valve is essential at a given current.

Specifications

Rated Flow	36 LPM (9.5 GPM) High Flow (‘SP’ Coil)
Maximum Input Pressure At Port 2	210 Bar (3000 PSI)
Minimum Pressure Differential	14 Bar (200 PSI)
Maximum Internal Leakage	780 cc (46 cu. in.) @ 210 Bar (3000 PSI)
Hysteresis @ 100 Hz PWM	7%
Variation of Flow @ 35% of Rated Current	Standard Model Up To ±20% Of Rated Flow Model “L” ±7% Of Rated Flow
Cartridge Material	All parts steel. All operating parts hardened steel.
Operating Temp. Range/Seals	-40°C to +93.3°C (Nitrile) (-40°F to +200°F) -31.7°C to +121.1°C (Fluorocarbon) (-25°F to +250°F)
Fluid Compatibility/ Viscosity	Mineral-based or synthetic with lubricating properties at viscosities of 45 to 2000 SSU (6 to 420 cSt)
Filtration	ISO Code 16/13, SAE Class 4 or better
Approx. Weight	.13 kg (.28 lbs.)
Cavity	3X (See BC Section for more details)

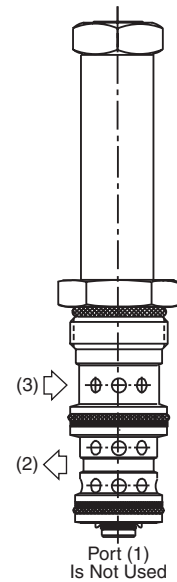
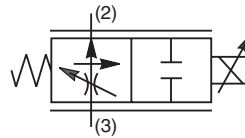

Performance Curves

▲ PWM Current Regulator Recommended

Flow vs. Input Current

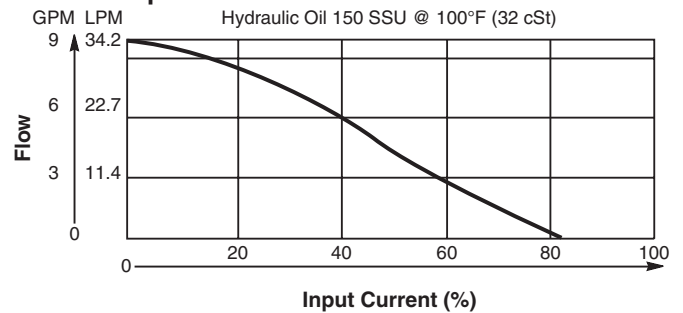

Flow Regulation

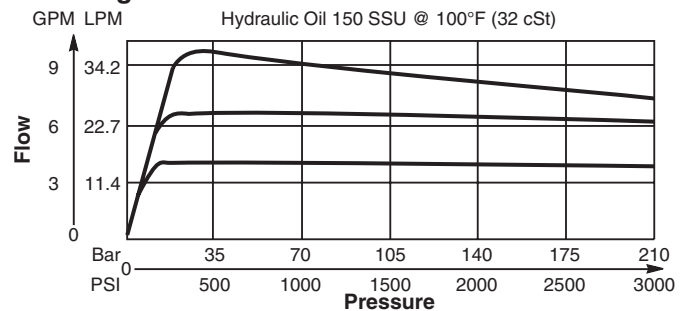

Pressure Drop vs. Flow

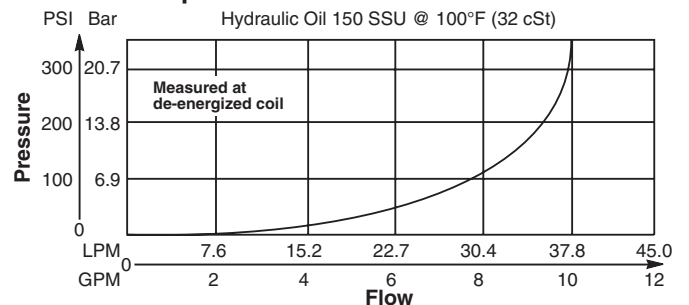

Dimensions Millimeters (Inches)

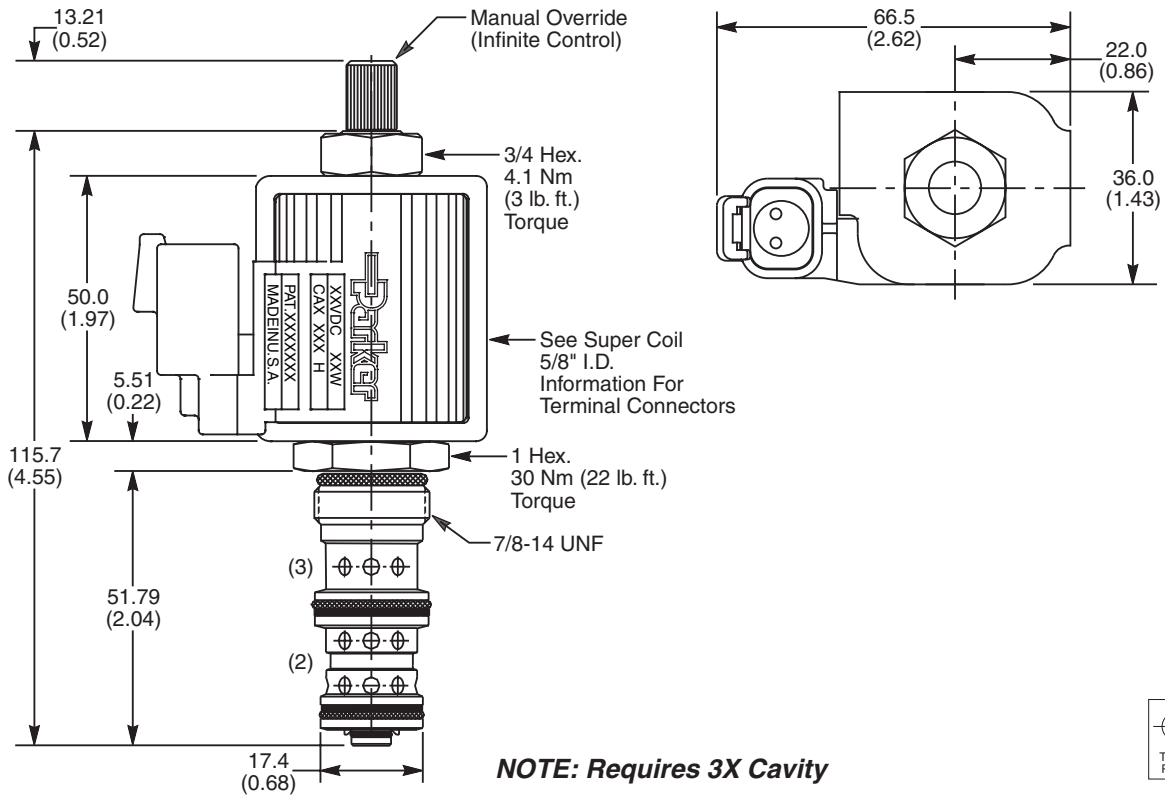

Ordering Information

JP04P **21**

10 Size Proportional Valve **Style** **Override Option** **Filter Screen** **Seals** **Flow Variation** **Coil Type** **Coil Voltage** **Coil Termination**

Code	Style (Maximum Regulated Flow)
21	High Flow ('SP' Coil) 36 LPM 9.5 GPM)

Code	Filter Screen
0	Not Required
1	60 Mesh Screen on Port 2

Code	Flow Variation
Omit	Standard Up to ±20% of Rated Flow
L	Low Variation (±7% of Rated Flow)

Code	Coil Voltage
Omit	Without Coil
D012	12 VDC
D024	24 VDC

Code	Override Option
0	Not Required
5	Detented M.O. (Infinite Control)

Code	Seals / Kit No.
N	Nitrile / Buna-N (Std.) (SK30106N-1)
V	Fluorocarbon / (SK30106V-1)

Code	Coil Type
Omit	Without Coil
SP	Super Coil - 28 Watts

Code	Coil Termination
Omit	Without Coil
D	DIN Plug Face
A	Amp Jr. Timer*
L	Dual Lead Wire*
LS	Sealed Lead Wire*
H	Molded Deutsch*

See Super Coil 5/8" I.D.
*DC Only

Order Bodies Separately

LB10

Line Body **Porting** **Body Material**

Code	Porting
553	1/2" SAE
554	3/8" BSP

Code	Body Material
A	Aluminum
S	Steel



- CV**
- Check Valves
- SH**
- Shuttle Valves
- LM**
- Load/Motor Controls
- FC**
- Flow Controls
- PC**
- Pressure Controls
- LE**
- Logic Elements
- DC**
- Directional Controls
- MV**
- Manual Valves
- SV**
- Solenoid Valves
- PV**
- Proportional Valves
- CE**
- Coils & Electronics
- BC**
- Bodies & Cavities
- TD**
- Technical Data

Technical Information

- CV** Check Valves
- SH** Shuttle Valves
- LM** Load/Motor Controls
- FC** Flow Controls
- PC** Pressure Controls
- LE** Logic Elements
- DC** Directional Controls
- MV** Manual Valves
- SV** Solenoid Valves
- PV** Proportional Valves
- CE** Coils & Electronics
- BC** Bodies & Cavities
- TD** Technical Data

General Description

Normally Open Proportional Flow Control Valve. For additional information see Technical Tips on pages PV1-PV6.

Features

- On-off type solenoids
- Low hysteresis
- PWM signal preferred
- Manual override standard
- All external parts zinc plated

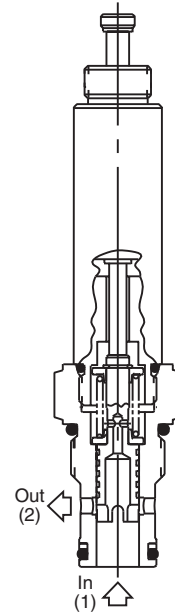
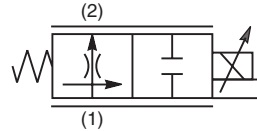
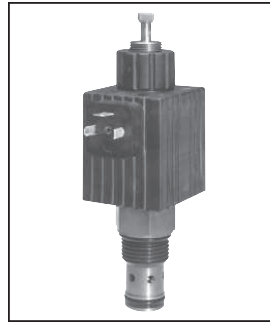

Specifications

Rated Flow Valve Fully Open	53 LPM (14 GPM)
Maximum Inlet Pressure	210 Bar (3000 PSI)
Hysteresis @ 200 Hz PWM	4%
Frequency	100 - 400 Hz (200 Hz Preferred)
Maximum Control Current	12 VDC 2.45A 24VDC 1.23A
Cartridge Material	All parts steel. All operating parts hardened steel.
Operating Temp. Range/Seals	-40°C to +93.3°C (Nitrile) (-40°F to +200°F) -31.7°C to +121.1°C (Fluorocarbon) (-25°F to +250°F)
Fluid Compatibility/Viscosity	Mineral-based or synthetic with lubricating properties at viscosities of 45 to 2000 SSU (6 to 420 cSt)
Filtration	ISO Code 16/13, SAE Class 4 or better
Approx. Weight	.32 kg (0.7 lbs.)
Cavity	C12-2 (See BC Section for more details)
Form Tool	Rougher None Finisher NFT12-2F

Note: 4.1 Bar (60psi) is required at port 1 to fully return Manual override.

Performance Curves

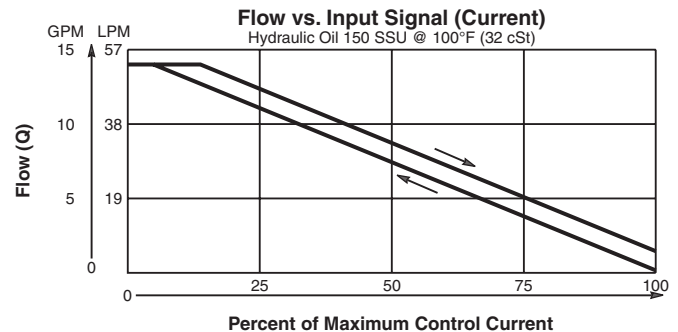
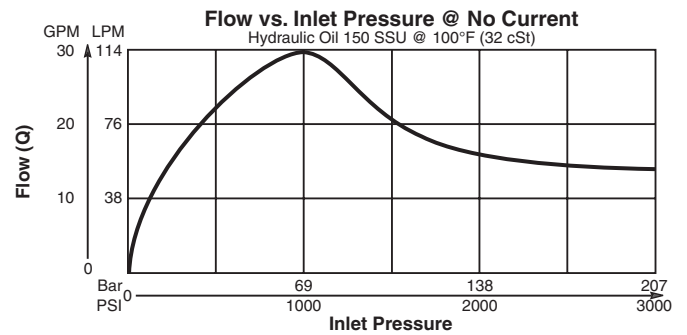
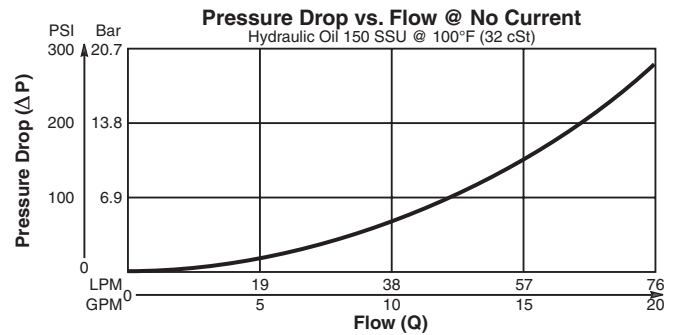

Technical Information

Dimensions Millimeters (Inches)

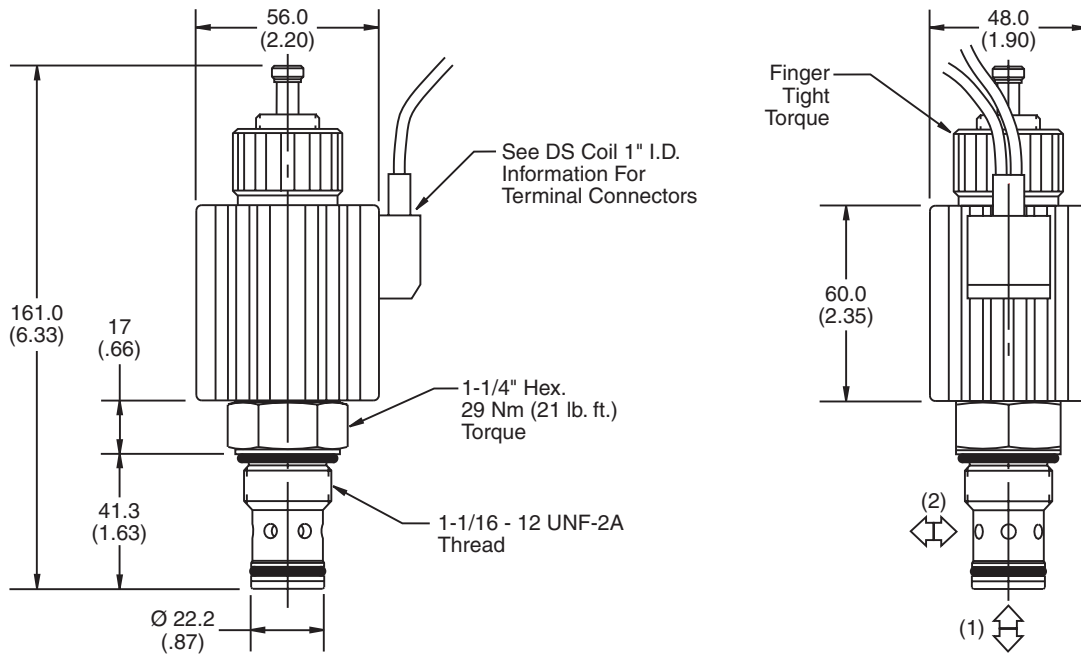

Ordering Information

DF122N14

12 Size Normally Open Proportional Flow Control Valve

Override Options Seals Coil Voltage Coil Wattage Coil Termination Body Material Port Size

Code	Override Options
Omit	Push Type with Extenden Rod

Code	Coil Voltage
Omit	Cartridge without Coil
D012	12 VDC
D024	24 VDC

Code	Coil Termination
Omit	Cartridge without Coil
D	DIN
P	Dual Spade
W	Dual Wire

Code	Body Material
Omit	Steel
A	Aluminum

Code	Seals / Kit. No.
Omit	Nitrile / (SK12-2)
V	Fluorocarbon / (SK12-2V)

Code	Coil Wattage
Omit	Cartridge without Coil
H	High Watt

See DS Coil 1" I.D.

Code	Port Size	Body Part No.
12P	3/4" NTPF	(B12-2-*12P)
8T	SAE - 8	(B12-2-*8T)
12T	SAE - 12	(B12-2-*12T)

* Add "A" for aluminum, omit for steel.

Technical Information

- CV** Check Valves
- SH** Shuttle Valves
- LM** Load/Motor Controls
- FC** Flow Controls
- PC** Pressure Controls
- LE** Logic Elements
- DC** Directional Controls
- MV** Manual Valves
- SV** Solenoid Valves
- PV** Proportional Valves
- CE** Coils & Electronics
- BC** Bodies & Cavities
- TD** Technical Data

General Description

3 Way, Normally Closed, Proportional Flow Regulator Valve. Pressure Compensated. For additional information see Technical Tips on pages PV1-PV6.

Features

- Analog proportional pressure compensated flow control valve regulates flow proportionally to the input solenoid current
- One piece cartridge housing ensures internal concentricity
- Coil: Waterproof, hermetically sealed, requires no O’Rings; Symmetrical coil can be reversed without affecting performance.
- Nonmagnetic spool and housing assembly
- Factory-adjusted low variation option (Model “L”) is available for applications where low variation of flow from valve to valve is essential at a given current.

Specifications

Rated Inlet Flow	60 LPM (16 GPM)				
Rated Regulated Flow	<table border="0"> <tr> <td>31</td> <td>26 LPM (7 GPM) Standard (‘SS’ Coil)</td> </tr> <tr> <td>31</td> <td>30 LPM (8 GPM) High Flow (‘SP’ Coil)</td> </tr> </table>	31	26 LPM (7 GPM) Standard (‘SS’ Coil)	31	30 LPM (8 GPM) High Flow (‘SP’ Coil)
31	26 LPM (7 GPM) Standard (‘SS’ Coil)				
31	30 LPM (8 GPM) High Flow (‘SP’ Coil)				
Maximum Input Pressure At Port 3	210 Bar (3000 PSI)				
Minimum Pressure Differential	<table border="0"> <tr> <td>31</td> <td>13.8 Bar (200 PSI) Standard</td> </tr> <tr> <td>31</td> <td>20.7 Bar (300 PSI) High Flow</td> </tr> </table>	31	13.8 Bar (200 PSI) Standard	31	20.7 Bar (300 PSI) High Flow
31	13.8 Bar (200 PSI) Standard				
31	20.7 Bar (300 PSI) High Flow				
Maximum Internal Leakage	780 cc (46 cu. in.) @ 210 Bar (3000 PSI)				
Hysteresis @ 100 Hz PWM	7%				
Opening Point	<table border="0"> <tr> <td>Standard</td> <td>21% of Nominal Amperage</td> </tr> <tr> <td>High Flow</td> <td>17% of Nominal Amperage</td> </tr> </table>	Standard	21% of Nominal Amperage	High Flow	17% of Nominal Amperage
Standard	21% of Nominal Amperage				
High Flow	17% of Nominal Amperage				
Variation of Opening Point	<table border="0"> <tr> <td>Standard Model</td> <td>Up To ±50% Of Amperage</td> </tr> <tr> <td>Model “L”</td> <td>±20% Of Amperage</td> </tr> </table>	Standard Model	Up To ±50% Of Amperage	Model “L”	±20% Of Amperage
Standard Model	Up To ±50% Of Amperage				
Model “L”	±20% Of Amperage				
Cartridge Material	All parts steel. All operating parts hardened steel.				
Operating Temp. Range/Seals	<table border="0"> <tr> <td>-40°C to +93.3°C (Nitrile)</td> <td>(-40°F to +200°F)</td> </tr> <tr> <td>-31.7°C to +121.1°C (Fluorocarbon)</td> <td>(-25°F to +250°F)</td> </tr> </table>	-40°C to +93.3°C (Nitrile)	(-40°F to +200°F)	-31.7°C to +121.1°C (Fluorocarbon)	(-25°F to +250°F)
-40°C to +93.3°C (Nitrile)	(-40°F to +200°F)				
-31.7°C to +121.1°C (Fluorocarbon)	(-25°F to +250°F)				
Fluid Compatibility/ Viscosity	Mineral-based or synthetic with lubricating properties at viscosities of 45 to 2000 SSU (6 to 420 cSt)				
Filtration	ISO Code 16/13, SAE Class 4 or better				
Approx. Weight	.14 kg (.31 lbs.)				
Cavity	4C (See BC Section for more details)				

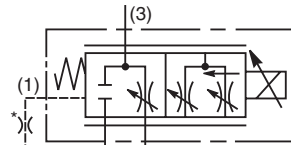

*Always connect Port (1) to Port (4) through .039" orifice.

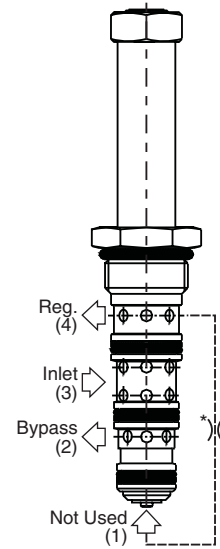

Performance Curves

▲ PWM Current Regulator Recommended

Pressure Compensation of Regulated Flow (Port 4)

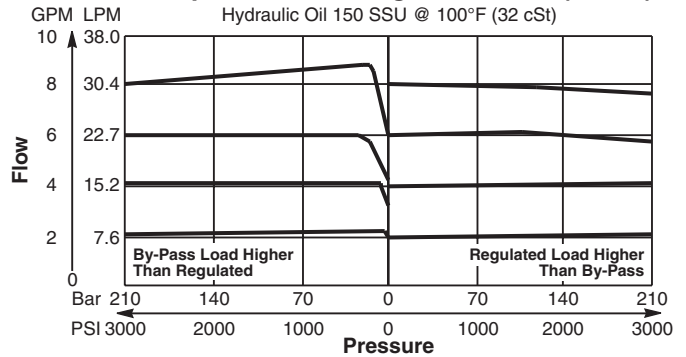

Regulated Flow vs. Input Current Stabilized

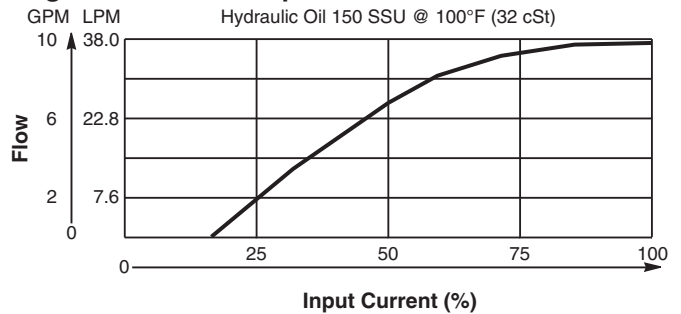

Pressure Drop vs. Flow at Coil Fully Energized

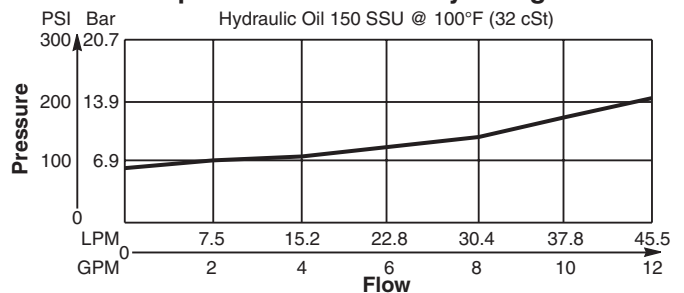

Dimensions Millimeters (Inches)

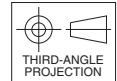
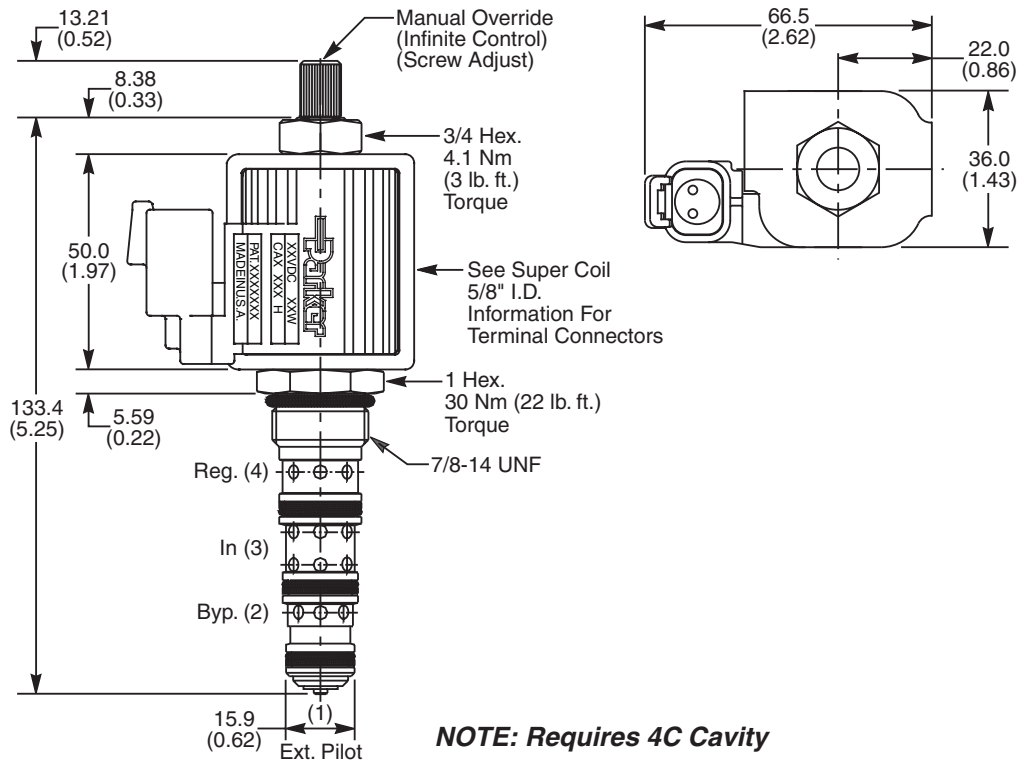

Ordering Information

JP04C	31							
10 Size Proportional Valve	Style	Override Option	Filter Screen	Seals	Flow Variation	Coil Type	Coil Voltage	Coil Termination

Code	Style (Maximum Regulated Flow)
31	Standard ('SS' Coil) 26 LPM (7 GPM)
31	High Flow ('SP' Coil) 30 LPM (8 GPM)

Code	Filter Screen
0	Not Available

Code	Seals / Kit No.
N	Nitrile / Buna-N (Std.) (SK30082N-1)
V	Fluorocarbon / (SK30082V-1)

Code	Flow Variation
Omit	Standard Up to ±50% of Opening Amps
L	Low Variation (±20% of Opening Amps)

Code	Coil Voltage
Omit	Without Coil
D012	12 VDC
D024	24 VDC

Code	Override Option
0	Not Required
5	Screw Adjust

Code	Coil Type
Omit	Without Coil
SS	Super Coil - 18 Watts
SP	Super Coil - 28 Watts

Code	Coil Termination
Omit	Without Coil
D	DIN Plug Face
A	Amp Jr. Timer*
L	Dual Lead Wire*
LS	Sealed Lead Wire*
H	Molded Deutsch*

See Super Coil 5/8" I.D.
*DC Only

Order Bodies Separately

LB10		
Line Body	Porting	Body Material

Code	Porting
562	1/2" SAE
563	3/8" BSP

Code	Body Material
A	Aluminum
S	Steel



- CV Check Valves
- SH Shuttle Valves
- LM Load/Motor Controls
- FC Flow Controls
- PC Pressure Controls
- LE Logic Elements
- DC Directional Controls
- MV Manual Valves
- SV Solenoid Valves
- PV Proportional Valves
- CE Coils & Electronics
- BC Bodies & Cavities
- TD Technical Data

Technical Information

- CV** Check Valves
- SH** Shuttle Valves
- LM** Load/Motor Controls
- FC** Flow Controls
- PC** Pressure Controls
- LE** Logic Elements
- DC** Directional Controls
- MV** Manual Valves
- SV** Solenoid Valves
- PV** Proportional Valves
- CE** Coils & Electronics
- BC** Bodies & Cavities
- TD** Technical Data

General Description

3 Way, Normally Closed, Proportional Flow Regulator Valve. Pressure Compensated. For additional information see Technical Tips on pages PV1-PV6.

Features

- Analog proportional pressure compensated flow control valve regulates flow proportionally to the input solenoid current
- One piece cartridge housing ensures internal concentricity
- Coil: Waterproof, hermetically sealed, requires no O'Rings; Symmetrical coil can be reversed without affecting performance.

Specifications

Rated Inlet Flow	75 LPM (20 GPM)
Rated Regulated Flow	56.8 LPM (15 GPM) Requires ('SP' Coil)
Maximum Input Pressure At Port 3	210 Bar (3000 PSI)
Minimum Pressure Differential	13.8 Bar (200 PSI)
Maximum Internal Leakage	568 cc (35 cu. in.) @ 210 Bar (3000 PSI)
Hysteresis @ 100 Hz PWM	>15%
Cartridge Material	All parts steel. All operating parts hardened steel.
Operating Temp. Range/Seals	-40°C to +93.3°C (Nitrile) (-40°F to +200°F) -31.7°C to +121.1°C (Fluorocarbon) (-25°F to +250°F)
Fluid Compatibility/ Viscosity	Mineral-based or synthetic with lubricating properties at viscosities of 45 to 2000 SSU (6 to 420 cSt)
Filtration	ISO Code 16/13, SAE Class 4 or better
Approx. Weight	.45 kg (1.0 lbs.)
Cavity	C12-4L (See BC Section for more details)

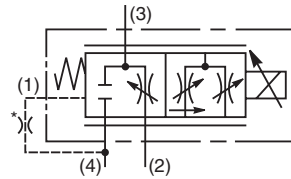

*Always connect Port (1) to Port (4) through .039" orifice.

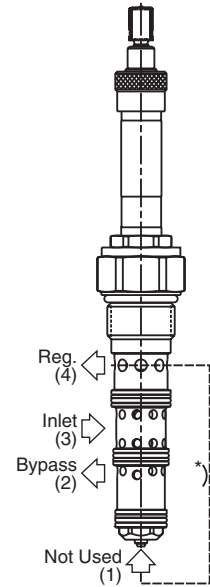

Performance Curves

▲ PWM Current Regulator Recommended

Pressure Compensation of Regulated Flow (Port 4)

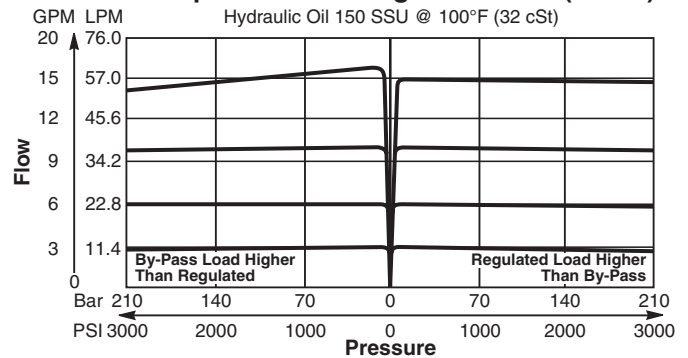

Regulated Flow vs. Input Current Stabilized

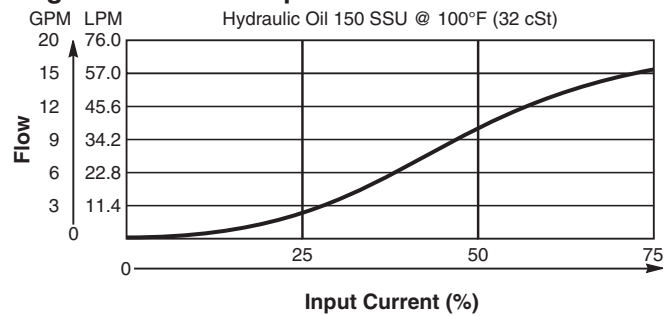

Pressure Drop vs. Flow (Through cartridge only)

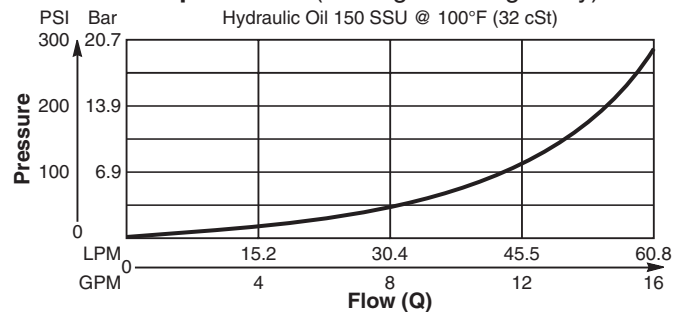

Dimensions Millimeters (Inches)

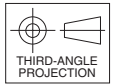
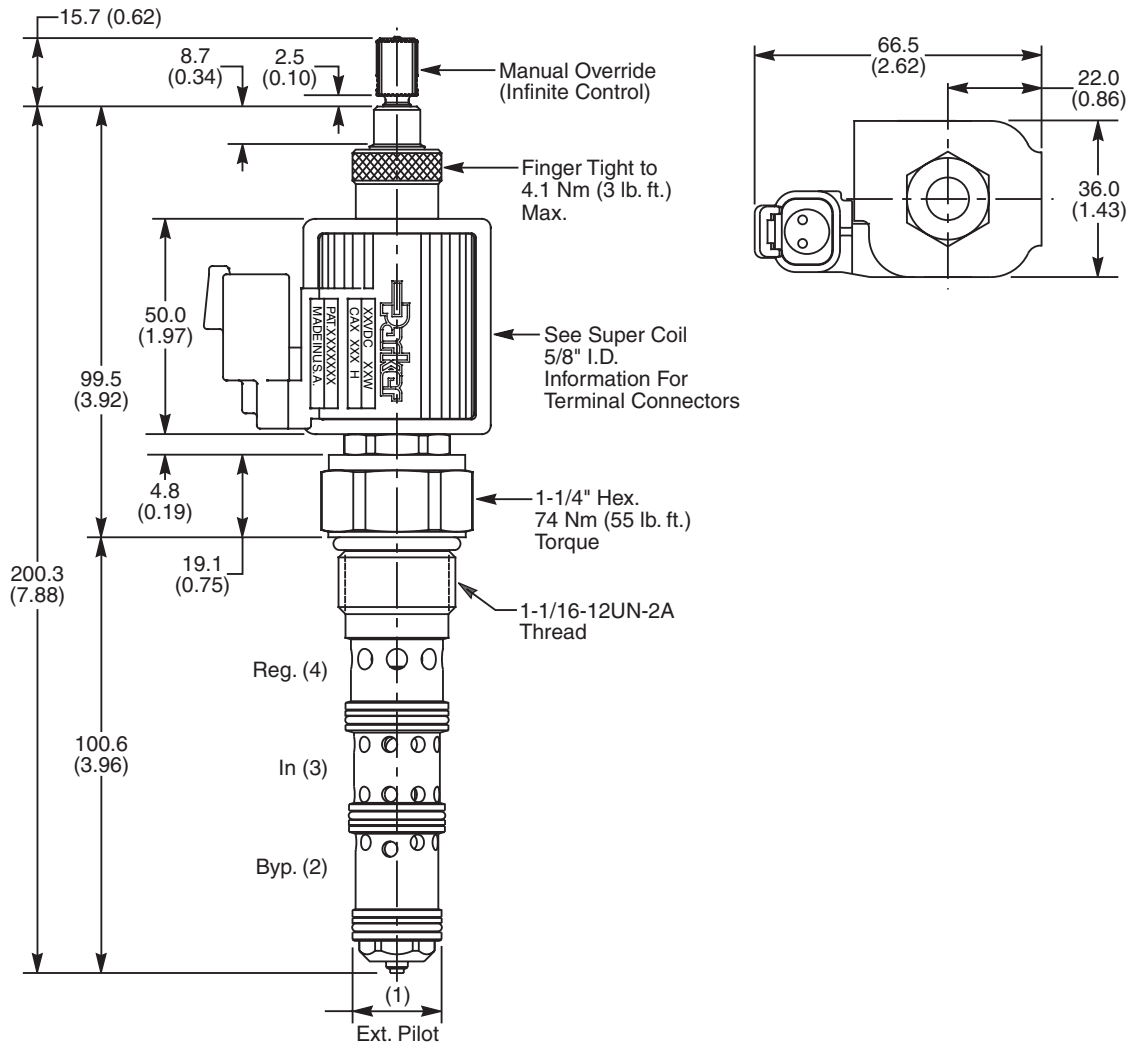

Ordering Information

DFA125C	31	S				
12 Size Proportional Valve	Style	Override Option	Seals	Coil Type	Coil Voltage	Coil Termination

Code	Style (Maximum Regulated Flow)
31	High Flow ("SP" Coil) 56.8 LPM (15 GPM)

Code	Coil Type
Omit	Without Coil
SP	Super Coil - 28 Watts

Code	Coil Termination
Omit	Without Coil
D	DIN Plug Face
A	Amp Jr. Timer*
S	Dual Spade*
L	Dual Lead Wire*
LS	Sealed Lead Wire*
H	Molded Deutsch*

See Super Coil 5/8" I.D.
*DC Only

Code	Override Option
Omit	Not Available
S	Standard M.O. (Infinite Control)

Code	Coil Voltage
Omit	Without Coil
D012	12 VDC
D024	24 VDC

Code	Seals / Kit No.
N	Nitrile / Buna-N (Std.) (SK12-4LN)
V	Fluorocarbon / (SK12-4LV)

Order Bodies Separately

B12	4L	A	12T
12 Size	4-Way Long Cavity	Body Material	Port Size

Code	Body Material
A	Aluminum

Code	Port Size
12T	SAE - 12



- CV** Check Valves
- SH** Shuttle Valves
- LM** Load/Motor Controls
- FC** Flow Controls
- PC** Pressure Controls
- LE** Logic Elements
- DC** Directional Controls
- MV** Manual Valves
- SV** Solenoid Valves
- PV** Proportional Valves
- CE** Coils & Electronics
- BC** Bodies & Cavities
- TD** Technical Data

Technical Information

- CV** Check Valves
- SH** Shuttle Valves
- LM** Load/Motor Controls
- FC** Flow Controls
- PC** Pressure Controls
- LE** Logic Elements
- DC** Directional Controls
- MV** Manual Valves
- SV** Solenoid Valves
- PV** Proportional Valves
- CE** Coils & Electronics
- BC** Bodies & Cavities
- TD** Technical Data

General Description

4 Way, 3 Position, Proportional Directional Control Valve. Closed Center Spool. For additional information see Technical Tips on pages PV1-PV6.

Features

- One piece cartridge housing ensures internal concentricity
- Coil: Waterproof, hermetically sealed, requires no O’Rings; Symmetrical coil can be reversed without affecting performance.

Specifications

Operating Pressure	Ports 2, 3 and 4 350 Bar (5000 PSI) Port 1 210 Bar (3000 PSI)
Hysteresis @ 100 Hz PWM	<6%
Cracking Flow	25% to 30% of Input Signal
Variation of Flow	±15% @ 75% of Nominal Current and Constant ΔP Maintained by Pressure Compensator
Port to Port Leakage	10 cu. in. @ 3000 PSI
Step Response Time at 75% of Amps	On 50 ms Off 40 ms
Cartridge Material	All parts steel. All operating parts hardened steel.
Operating Temp. Range/Seals	-40°C to +93.3°C (Nitrile) (-40°F to +200°F) -31.7°C to +121.1°C (Fluorocarbon) (-25°F to +250°F)
Fluid Compatibility/Viscosity	Mineral-based or synthetic with lubricating properties at viscosities of 45 to 2000 SSU (6 to 420 cSt)
Filtration	ISO Code 16/13, SAE Class 4 or better
Approx. Weight	.15 kg (.34 lbs.)
Cavity	C08-4

Typical Performance

SPOOL TYPE AND FLOW	RATED FLOW AT 75% OF NOMINAL CURRENT LPM - (GPM)		SUPER COIL TYPE		Compensator ΔP Bar (PSI)
	'a' SOLENOID PUSH P to A, B to T	'b' SOLENOID PULL P to B, A to T	PUSH	PULL	
51L Low Flow	5.3 - (1.4)	5.3 - (1.4)	SP	SP	10 (150)
	3.4 - (0.9)	3.4 - (0.9)	SS	SS	5 (75)
51 Standard	13.3 - (3.5)	17 - (4.5)	SP	SP	15 (220)
	11.4 - (3.0)	15.2 - (4.0)	SS	SS	15 (220)
52 High Flow	21 - (5.5)	17 - (4.5)	SP	SP	20 (290)
	17.4 - (4.5)	13 - (3.5)	SP	SP	15 (220)

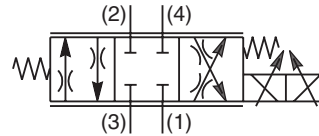
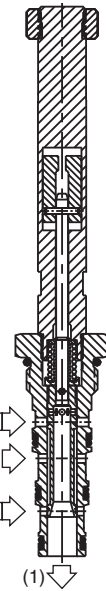

Performance Curves

▲ PWM Current Regulator Recommended

51L With 5 Bar, 75 PSI Compensator
51 With 15 Bar, 220 PSI Compensator and SS Coil

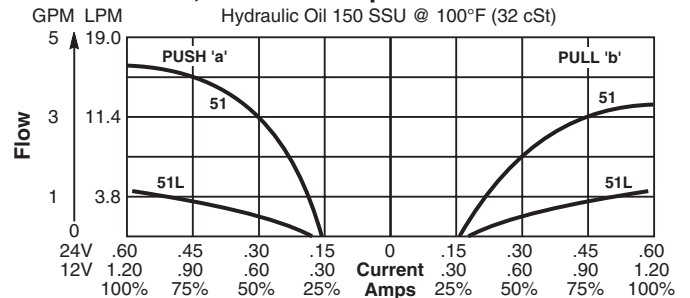

52 With 20 Bar, 290 PSI Compensator and SP Coil

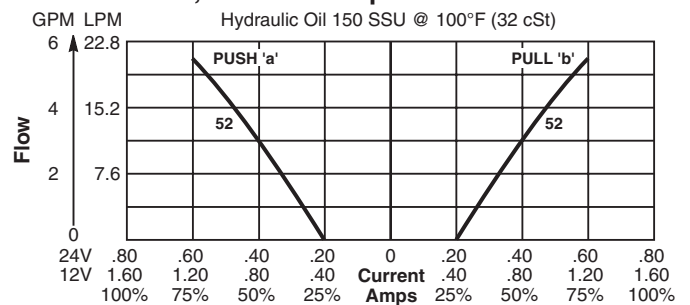

Flow vs. Load

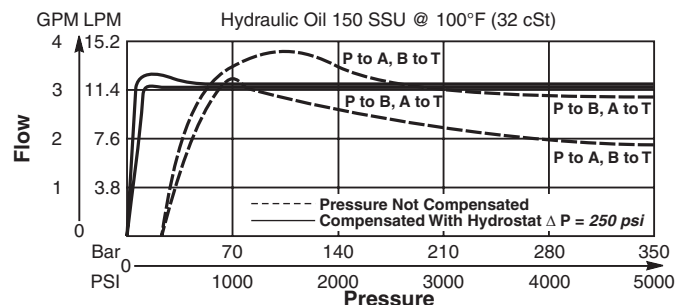

Technical Information

Dimensions Millimeters (Inches)

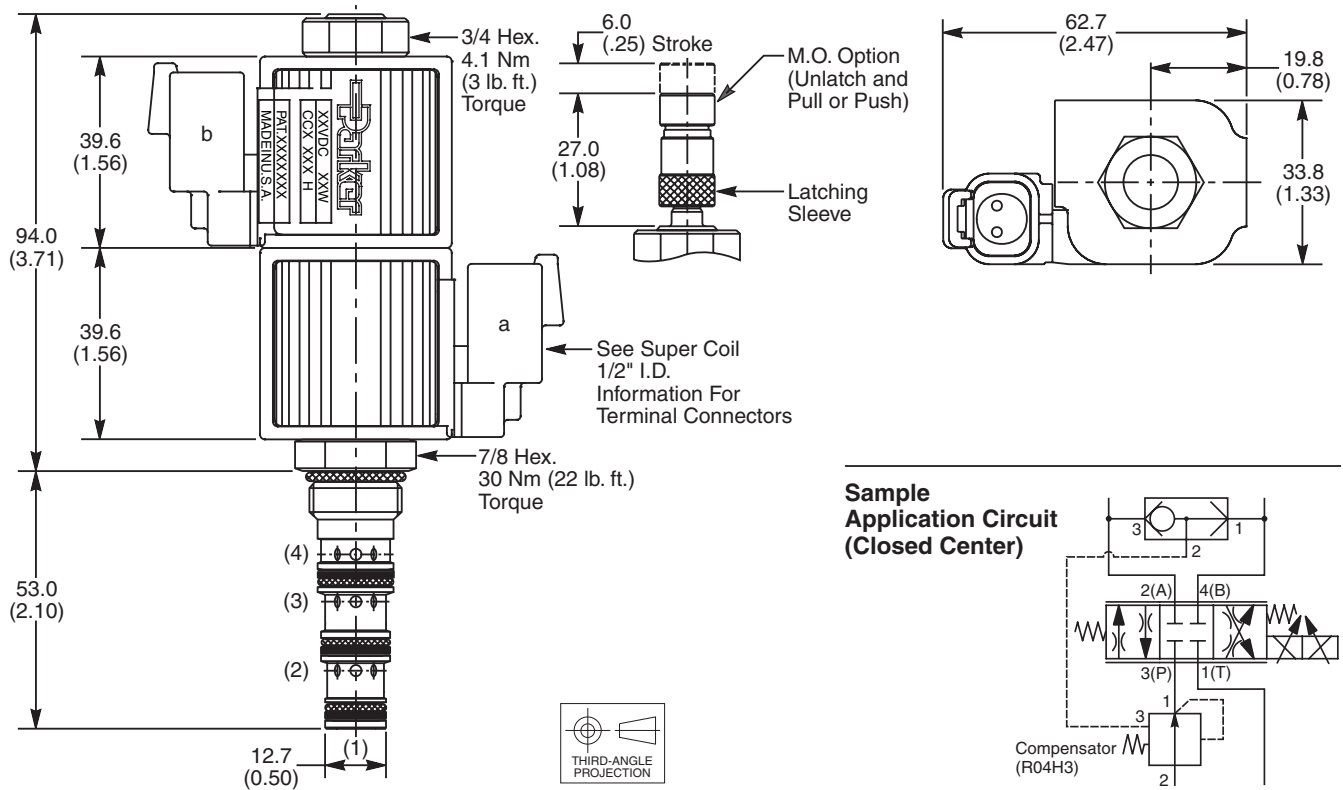

Ordering Information

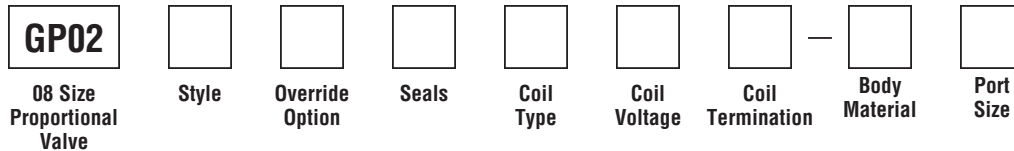

Code	Style - Closed Center (Flow Pressure and Performance)
51	Standard
51L	Low Flow
52	High Flow

Code	Seals / Kit No.
N	Nitrile / Buna-N (Std.) (SK30078N-1)
V	Fluorocarbon / (SK30078V-1)

Code	Coil Voltage
Omit	Without Coil
D012	12 VDC
D024	24 VDC

Code	Body Material
Omit	Steel
A	Aluminum

Code	Override Option
Omit	Not Required
1	Manual Override
2	Detented M.O.

Code	Coil Type
Omit	Without Coil
SS	Super Coil - 14 Watts
SP	Super Coil - 19 Watts

Code	Coil Termination
Omit	Without Coil
D	DIN Plug Face
A	Amp Jr. Timer*
L	Dual Lead Wire*
LS	Sealed Lead Wire*
H	Molded Deutsch*

Code	Port Size	Body Part No.
Omit	Cartridge Only	
4T	SAE-4	(B08-4-*4T)
6T	SAE-6	(B08-4-*6T)
6B	3/8" BSPG	(B08-4-*6B)

* Add "A" for aluminum, omit for steel.

See Super Coil 1/2" I.D.
*DC Only

- CV
- Check Valves
- SH
- Shuttle Valves
- LM
- Load/Motor Controls
- FC
- Flow Controls
- PC
- Pressure Controls
- LE
- Logic Elements
- DC
- Directional Controls
- MV
- Manual Valves
- SV
- Solenoid Valves
- PV
- Proportional Valves
- CE
- Coils & Electronics
- BC
- Bodies & Cavities
- TD
- Technical Data

Technical Information

- CV** Check Valves
- SH** Shuttle Valves
- LM** Load/Motor Controls
- FC** Flow Controls
- PC** Pressure Controls
- LE** Logic Elements
- DC** Directional Controls
- MV** Manual Valves
- SV** Solenoid Valves
- PV** Proportional Valves
- CE** Coils & Electronics
- BC** Bodies & Cavities
- TD** Technical Data

General Description

4 Way, 3 Position, Proportional Directional Control Valve. Floating Center Spool. For additional information see Technical Tips on pages PV1-PV6.

Features

- One piece cartridge housing ensures internal concentricity
- Coil: Waterproof, hermetically sealed, requires no O'Rings; Symmetrical coil can be reversed without affecting performance.

Specifications

Operating Pressure	Ports 2, 3 and 4 350 Bar (5000 PSI) Port 1 210 Bar (3000 PSI)
Hysteresis @ 100 Hz PWM	<6%
Cracking Flow	25% to 30% of Input Signal
Variation of Flow	±15% @ 75% of Nominal Current and Constant ΔP Maintained by Pressure Compensator
Port to Port Leakage	10 cu. in. @ 3000 PSI
Step Response Time at 75% of Amps	On 50 ms Off 40 ms
Cartridge Material	All parts steel. All operating parts hardened steel.
Operating Temp. Range/Seals	-40°C to +93.3°C (Nitrile) (-40°F to +200°F) -31.7°C to +121.1°C (Fluorocarbon) (-25°F to +250°F)
Fluid Compatibility/Viscosity	Mineral-based or synthetic with lubricating properties at viscosities of 45 to 2000 SSU (6 to 420 cSt)
Filtration	ISO Code 16/13, SAE Class 4 or better
Approx. Weight	.15 kg (.34 lbs.)
Cavity	C08-4

Typical Performance

SPOOL TYPE AND FLOW	RATED FLOW AT 75% OF NOMINAL CURRENT LPM - (GPM)		SUPER COIL TYPE		Compensator ΔP Bar (PSI)
	'a' SOLENOID PUSH P to A, B to T	'b' SOLENOID PULL P to B, A to T	PUSH	PULL	
53L Low Flow	5.3 - (1.4)	5 - (1.4)	SP	SP	10 (150)
	4 - (1.0)	4 - (1.0)	SS	SS	5 (75)
53 Standard	14 - (3.8)	15 - (4.0)	SP	SP	10 (150)
	9 - (2.5)	10 - (2.7)	SS	SS	5 (75)
54 High Flow	17 - (4.5)	19 - (5.0)	SP	SP	20 (290)
	15 - (4.0)	15 - (4.0)	SS	SS	15 (220)

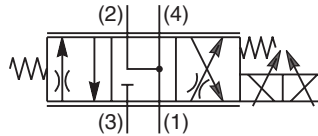
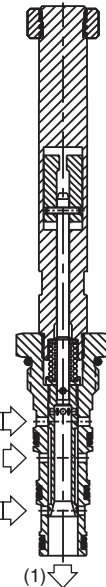

Performance Curves

▲ PWM Current Regulator Recommended
53 and 53L With 5 Bar, 75 PSI Compensator and SS Coil

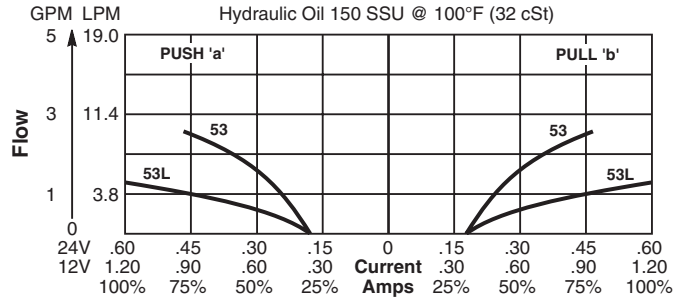

54 With 20 Bar, 290 PSI Compensator and SP Coil

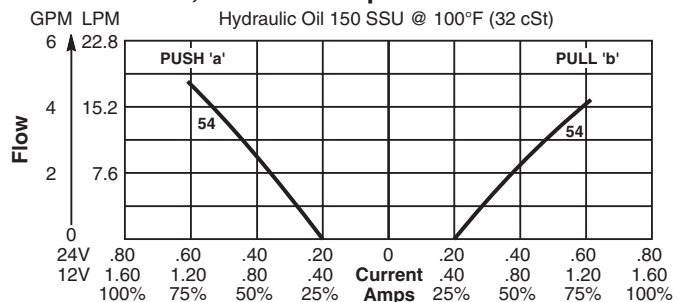

Flow vs. Load

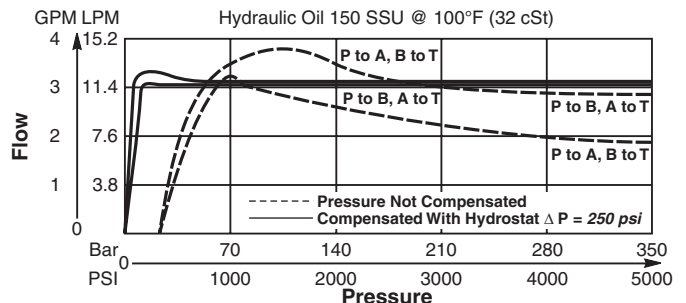

Technical Information

Dimensions Millimeters (Inches)

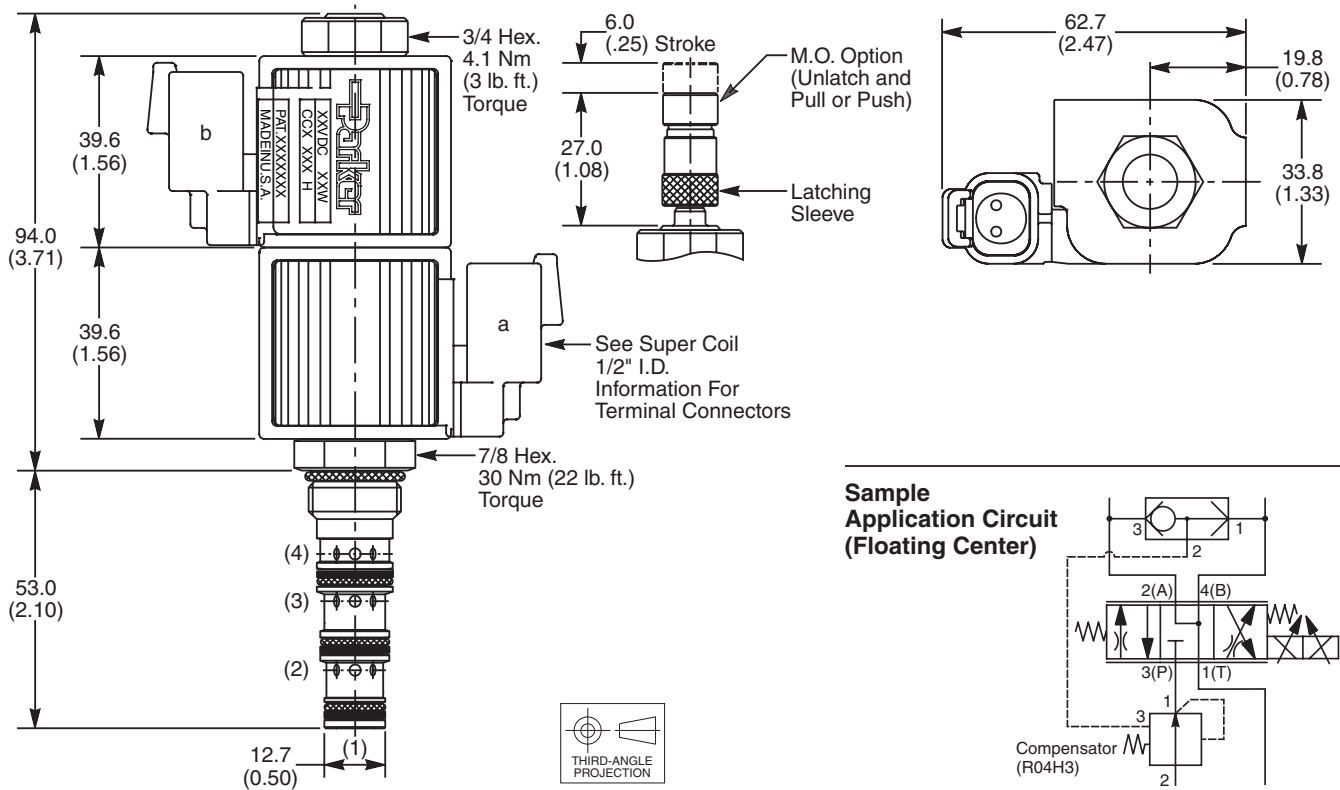

Ordering Information

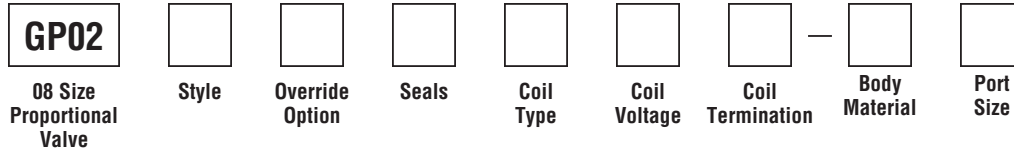

Code	Style - Floating Center (Flow Pressure and Performance)
53	Standard
53L	Low Flow
54	High Flow

Code	Seals / Kit No.
N	Nitrile / Buna-N (Std.) (SK30078N-1)
V	Fluorocarbon / (SK30078V-1)

Code	Coil Voltage
Omit	Without Coil
D012	12 VDC
D024	24 VDC

Code	Body Material
Omit	Steel
A	Aluminum

Code	Override Option
Omit	Not Required
1	Manual Override
2	Detented M.O.

Code	Coil Type
Omit	Without Coil
SS	Super Coil - 14 Watts
SP	Super Coil - 19 Watts

Code	Coil Termination
Omit	Without Coil
D	DIN Plug Face
A	Amp Jr. Timer*
L	Dual Lead Wire*
LS	Sealed Lead Wire*
H	Molded Deutsch*

Code	Port Size	Body Part No.
Omit	Cartridge Only	
4T	SAE-4	(B08-4-*4T)
6T	SAE-6	(B08-4-*6T)
6B	3/8" BSPG	(B08-4-*6B)

* Add "A" for aluminum, omit for steel.

See Super Coil 1/2" I.D.
*DC Only

Technical Information

- CV** Check Valves
- SH** Shuttle Valves
- LM** Load/Motor Controls
- FC** Flow Controls
- PC** Pressure Controls
- LE** Logic Elements
- DC** Directional Controls
- MV** Manual Valves
- SV** Solenoid Valves
- PV** Proportional Valves
- CE** Coils & Electronics
- BC** Bodies & Cavities
- TD** Technical Data

General Description

4 Way, 3 Position, Proportional Directional Control Valve. Closed Center or Floating Center Spool. For additional information see Technical Tips on pages PV1-PV6.

Features

- One piece cartridge housing ensures internal concentricity
- Coil: Waterproof, hermetically sealed, requires no O'Rings; Symmetrical coil can be reversed without affecting performance.
- All external parts zinc plated

Specifications

Operating Pressure	210 Bar (3000 PSI)
Hysteresis @ 100 Hz PWM	<6%
Cracking Flow	25% to 30% of Input Signal
Variation of Flow	±15% @ 75% of Nominal Current and Constant ΔP Maintained by Pressure Compensator
Port to Port Leakage	10 cu. in. @ 3000 PSI
Step Response Time at 75% of Amps	On 50 ms Off 40 ms
Cartridge Material	All parts steel. All operating parts hardened steel.
Operating Temp. Range/Seals	-45°C to +93.3°C ("D"-Ring) (-50°F to +200°F) -31.7°C to +121.1°C (Fluorocarbon) (-25°F to +250°F)
Fluid Compatibility/ Viscosity	Mineral-based or synthetic with lubricating properties at viscosities of 45 to 2000 SSU (6 to 420 cSt)
Filtration	ISO Code 16/13, SAE Class 4 or better
Approx. Weight	.28 kg (.57 lbs.)
Cavity	C10-4

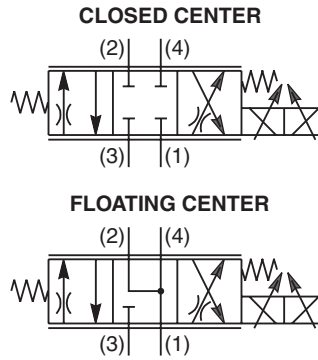
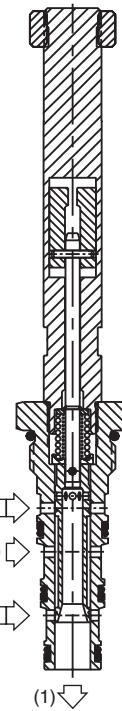

Sample Application Circuit

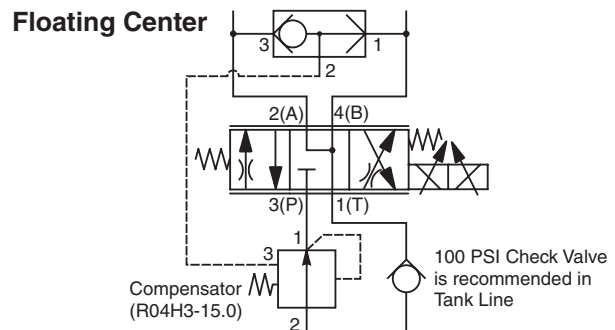
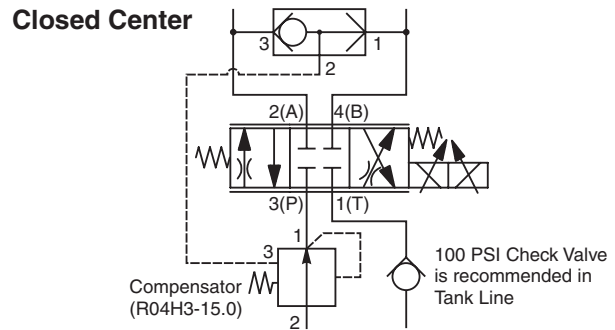

Dimensions Millimeters (Inches)

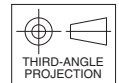
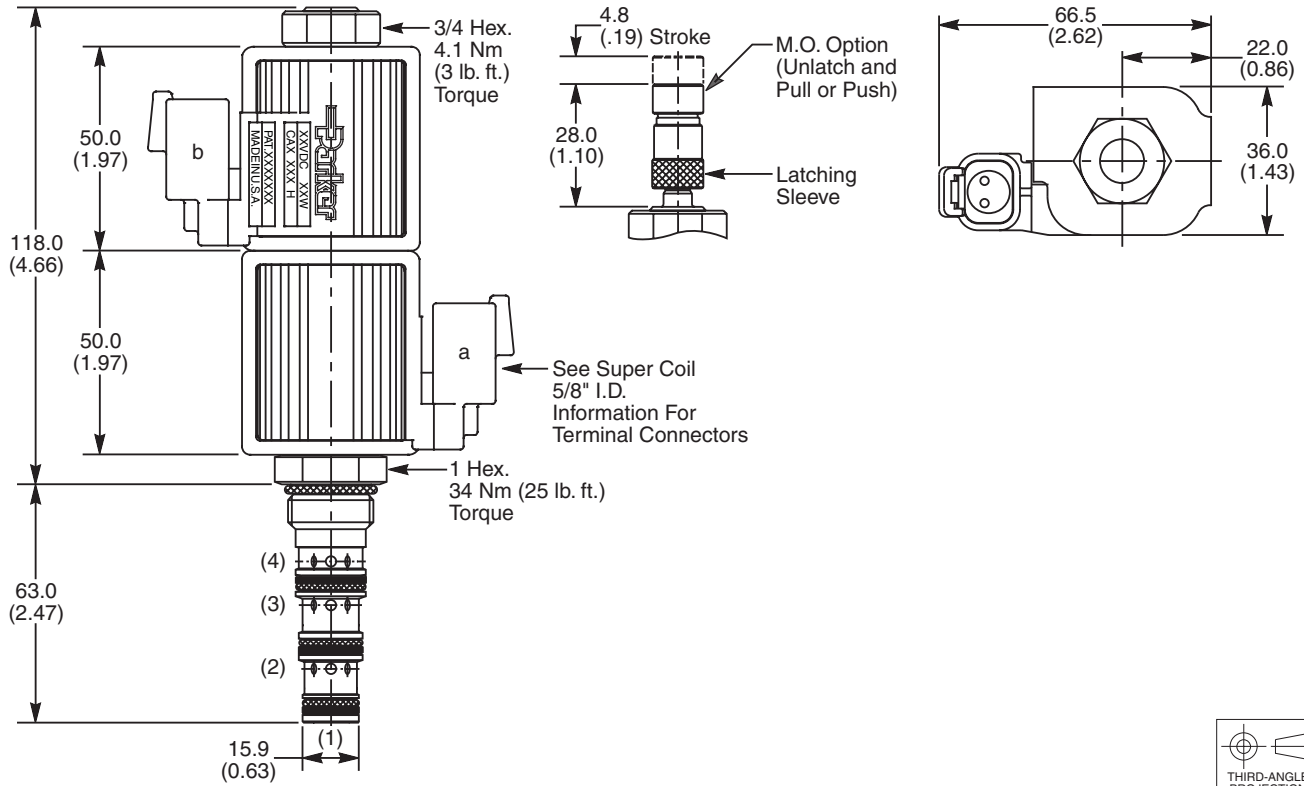

Ordering Information

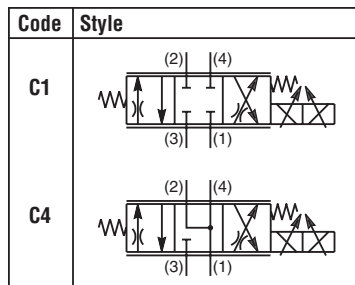
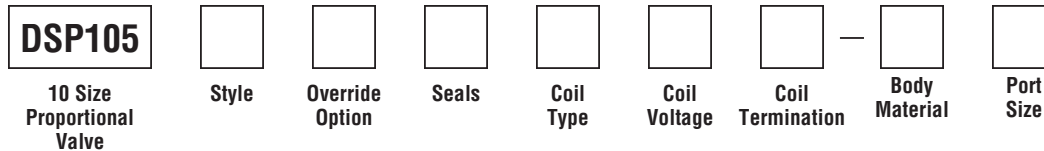

Code	Seals / Kit No.
Omit	"D"-Ring / (SK10-4)
N	Nitrile / (SK10-4N)
V	Fluorocarbon / (SK10-4V)

Code	Coil Type
Omit	Without Coil
SP	Super Coil - 28 Watts

Code	Coil Voltage
Omit	Without Coil
D012	12 VDC
D024	24 VDC

Code	Coil Termination
Omit	Without Coil
D	DIN Plug Face
A	Amp Jr. Timer*
L	Dual Lead Wire*
H	Molded Deutsch*

Code	Body Material
Omit	Steel
A	Aluminum

Code	Port Size	Body Part No.
Omit	Cartridge Only	
6P	3/8" NPTF	(B10-4-*6P)
6T	SAE-6	(B10-4-*6T)
8T	SAE-8	(B10-4-*8T)
6B	3/8" BSPG	(B10-4-6B)†

* Add "A" for aluminum, omit for steel.
† Steel body only.

Code	Override Option
Omit	None
M	Push/Pull

See Super Coil 5/8" I.D.
*DC Only

- CV Check Valves
- SH Shuttle Valves
- LM Load/Motor Controls
- FC Flow Controls
- PC Pressure Controls
- LE Logic Elements
- DC Directional Controls
- MV Manual Valves
- SV Solenoid Valves
- PV Proportional Valves
- CE Coils & Electronics
- BC Bodies & Cavities
- TD Technical Data

- CV** Check Valves
- SH** Shuttle Valves
- LM** Load/Motor Controls
- FC** Flow Controls
- PC** Pressure Controls
- LE** Logic Elements
- DC** Directional Controls
- MV** Manual Valves
- SV** Solenoid Valves
- PV** Proportional Valves
- CE** Coils & Electronics
- BC** Bodies & Cavities
- TD** Technical Data

▲ PWM Current Regulator Recommended

51 With 15 Bar, 220 PSI Compensator and SP Coil

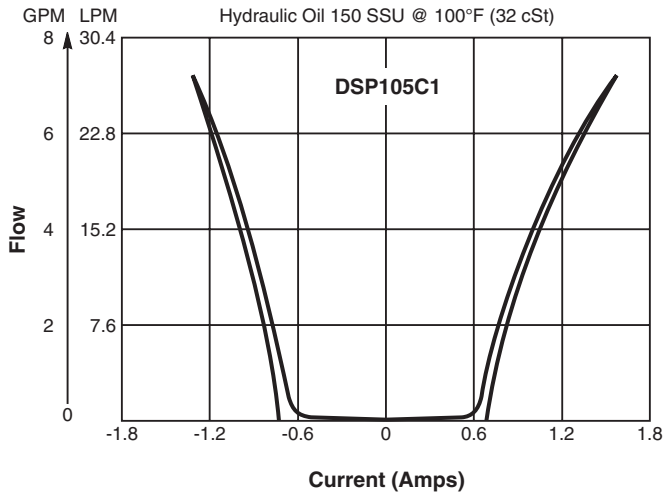

53 With 15 Bar, 220 PSI Compensator and SP Coil

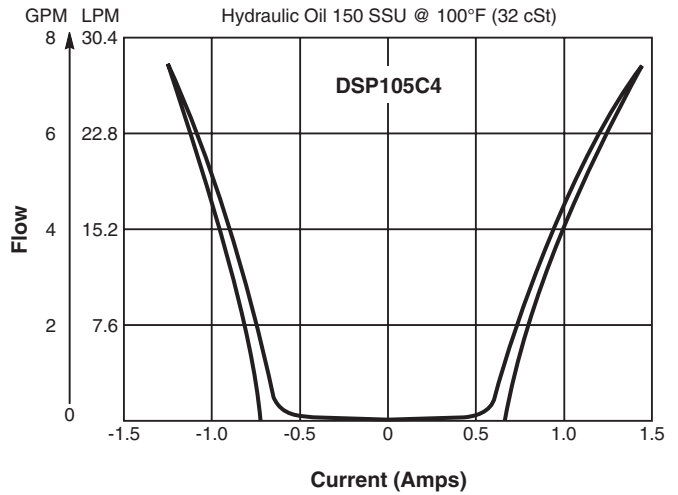

**Pressure Compensation Pull Coil
 Inlet to Work Port**

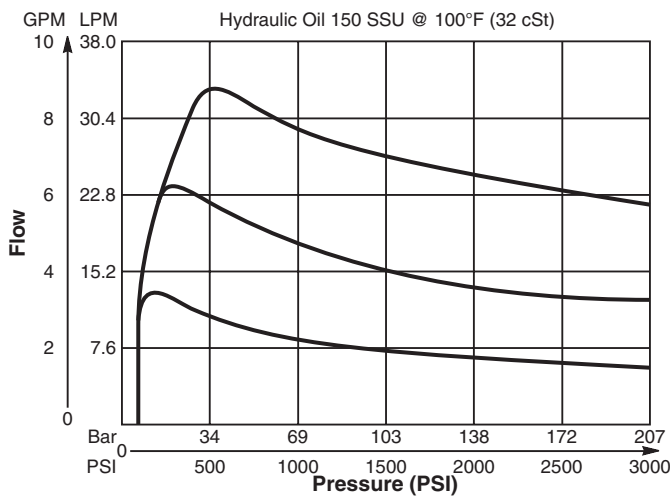

**Pressure Compensation Push Coil
 Inlet to Work Port**

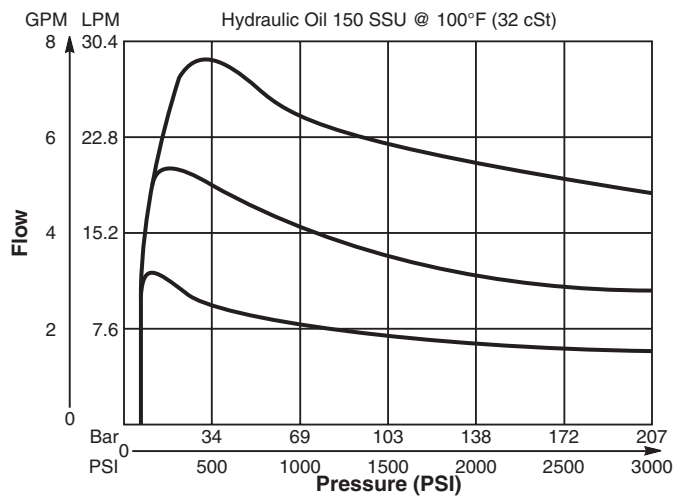

51 Spool Port 3 to 4

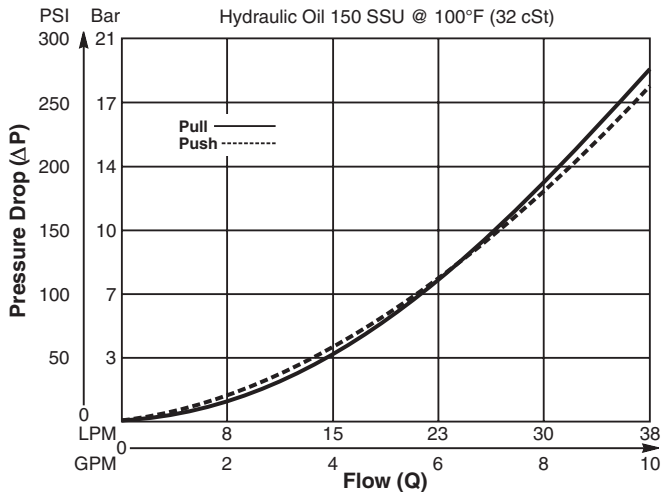

Contents

Shuttle Valves

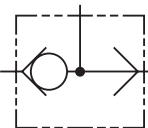
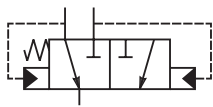
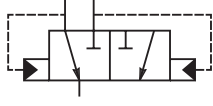
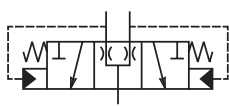
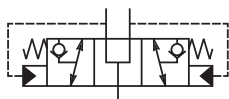
	SERIES	CAVITY	DESCRIPTION	FLOW LPM/GPM	PRESSURE BAR/PSI	PAGE NO.
	KSWA3	SW-3	Ball Insert Type	9.5/2.5	420/6000	SH3
	K2A005	3Z	Poppet Insert Type	38/10	350/5000	SH4
	CS041B	C04-3	Cartridge Shuttle	3.8/1.0	207/3000	SH5
	K02A3	C08-3	Cartridge Shuttle	50/13	420/6000	SH6
	CSH101B	C10-3	Cartridge Shuttle	38/10	350/5000	SH7
	ASH-04		In-Line Shuttle,-4 Male JIC	11/3	207/3000	SH8-SH9
	ASH-06		In-Line Shuttle,-6T	22/6	207/3000	SH8-SH9
	K04B3	C10-3	Spool Type Shuttle	90/24	420/6000	SH10
	K04D3	C10-3	Spool Type Shuttle	90/24	420/6000	SH11
	K04C3	C10-4	Spool Type, Spring Centered, All Ports Closed	100/26	420/6000	SH12
	K3A125	3U	Spool Type, Spring Centered, All Ports Closed	175/46	350/5000	SH13
	K04F3	C10-4	Spool Type, Spring Centered, All Ports Open	100/26	420/6000	SH14
	K04G3	C10-4	Spool Type Shuttle, Inverse	50/13	350/5000	SH15

CV
Check Valves
SH
Shuttle Valves
LM
Load/Motor Controls
FC
Flow Controls
PC
Pressure Controls
LE
Logic Elements
DC
Directional Controls
MV
Manual Valves
SV
Solenoid Valves
PV
Proportional Valves
CE
Coils & Electronics
BC
Bodies & Cavities
TD
Technical Data



- CV** Check Valves
- SH** Shuttle Valves
- LM** Load/Motor Controls
- FC** Flow Controls
- PC** Pressure Controls
- LE** Logic Elements
- DC** Directional Controls
- MV** Manual Valves
- SV** Solenoid Valves
- PV** Proportional Valves
- CE** Coils & Electronics
- BC** Bodies & Cavities
- TD** Technical Data

INTRODUCTION:

Shuttle valves accept flow from two different sources and divert the highest pressure to a single outlet port. Shuttle valves are commonly used in Load Sensing circuits as well as Brake circuits. Parker offers many different types of shuttles, including ball type, poppet type, spool type. There are a number of configurations available such as cartridge type, insert type, and an in-line version.

Ball Type - Cartridge Style

The valve consists of a steel ball that can seal against one of two adjacent seats, providing a path from the highest pressure signal to another function.

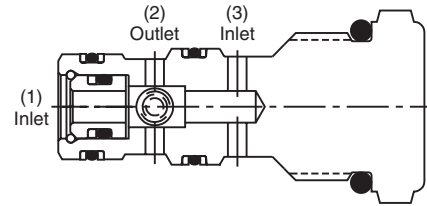
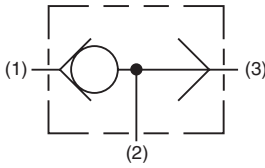

When one inlet port is pressurized, the ball or poppet is forced against the opposite seat, blocking that inlet and providing a flow path to the outlet port.

Poppet Type - Insert Style

This shuttle performs the same function, but allows for higher flow rates due to poppet design.

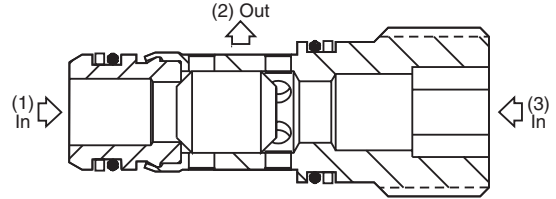
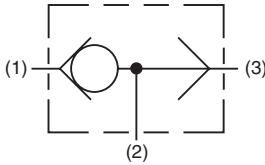

In-Line Type

This shuttle variant performs the same function in a self-contained body. It can be mounted anywhere on the machine.

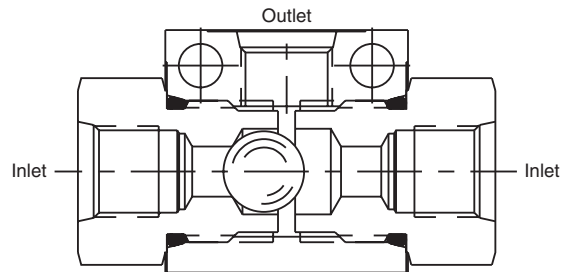
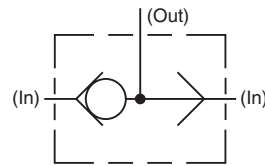

Spool Type - Centered or Spring Offset

The spool type shuttle allows for higher flow rates. These are 2 position valves.

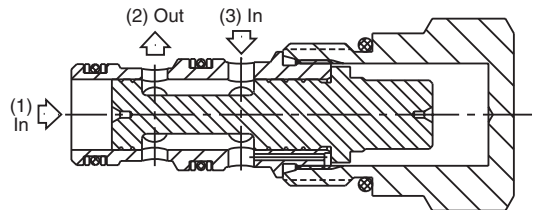
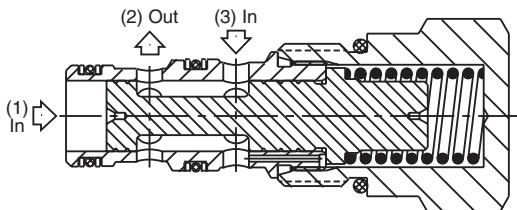
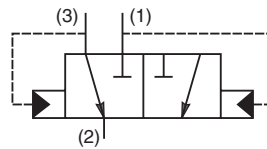
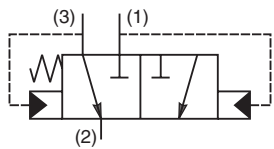

3 Way 2 Position Spool type shuttles are designed to direct flow in such a way as to allow higher pressure signals to open the lower pressure port and connect it to the common outlet port. These spring centered valves will shift when pressure at either end of the spool exceed the spring setting. These are typically used in transmission hot oil shuttle circuits.

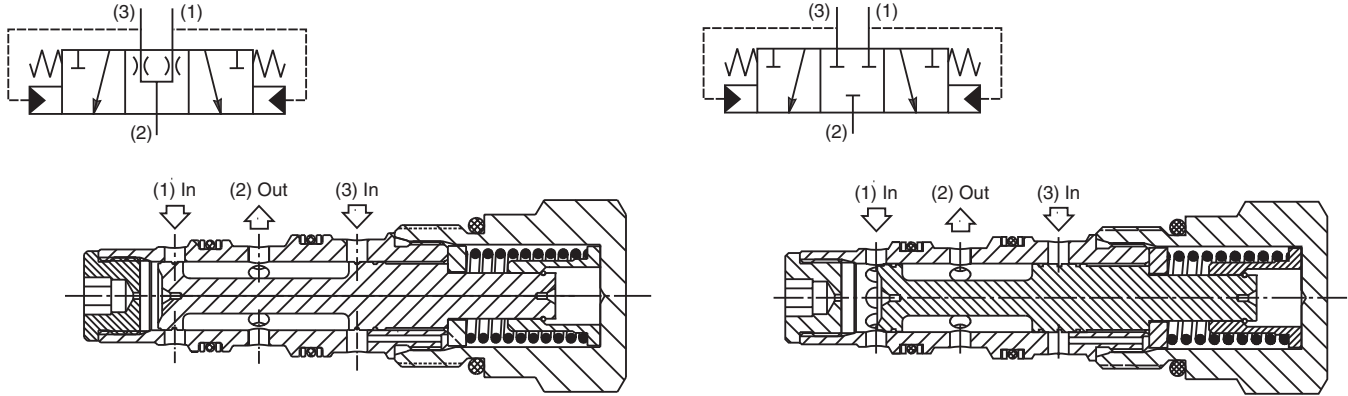

CV
Check Valves
SH
Shuttle Valves
LM
Load/Motor Controls
FC
Flow Controls
PC
Pressure Controls
LE
Logic Elements
DC
Directional Controls
MV
Manual Valves
SV
Solenoid Valves
PV
Proportional Valves
CE
Coils & Electronics
BC
Bodies & Cavities
TD
Technical Data

Technical Information

General Description

Ball Type, Two Position, Three Way Shuttle Valve.
For additional information see Technical Tips on pages SH1-SH2.

Features

- Compact, cost effective design
- Ball type construction for maximum durability
- Minimal leakage - less than 3 drops/min.
- Contamination tolerant
- Hardened working parts for maximum durability
- All external parts zinc plated

Performance Curve

Pressure Drop vs. Flow (Through cartridge only)

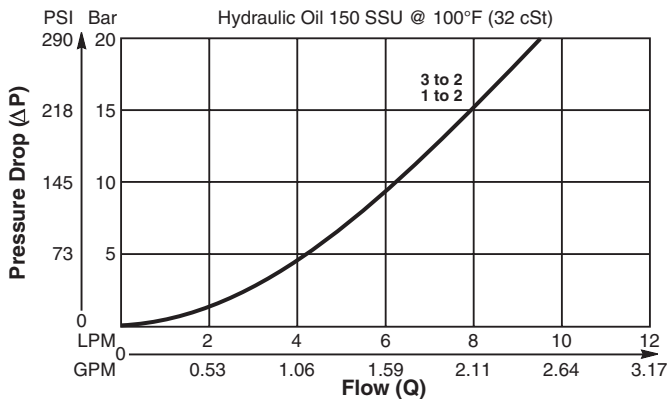

Specifications

Rated Flow	9.5 LPM (2.5 GPM)
Nominal Flow @ 7 Bar (100 PSI)	5 LPM (1.32 GPM)
Maximum Inlet Pressure	420 Bar (6000 PSI)
Cartridge Material	All parts steel. All operating parts hardened steel.
Operating Temp. Range/Seals	-40°C to +93.3°C (Nitrile, Buna-N) (-40°F to +200°F) -31.7°C to +121.1°C (Fluorocarbon) (-25°F to +250°F)
Fluid Compatibility/Viscosity	Mineral-based or synthetic with lubricating properties at viscosities of 45 to 2000 SSU (6 to 420 cSt)
Filtration	ISO code 16/13, SAE Class 4 or better
Approx. Weight	.01 kg (.02 lbs.)
Cavity	CAVSW-3 (See BC Section for more details)

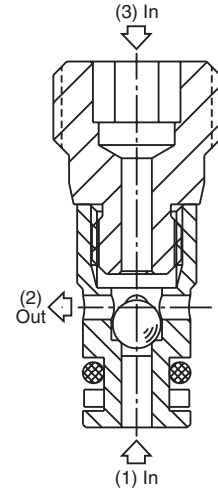
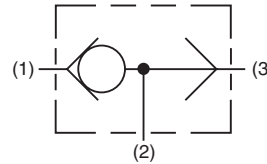

Dimensions

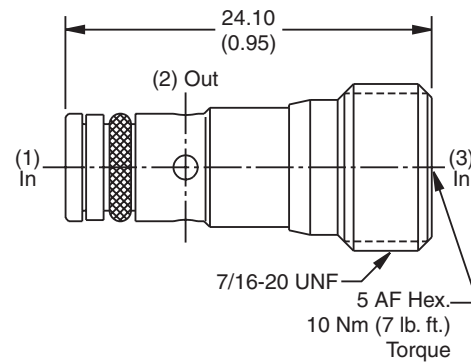

Application

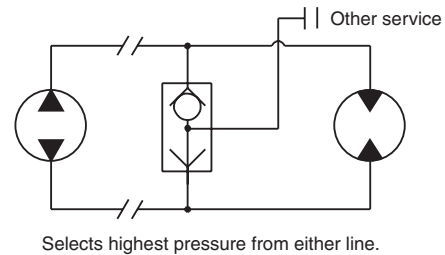

Ordering Information

KSWA3 Shuttle Valve

Seals

Order Bodies Separately

LB10 Line Body Porting Body Material

Code	Seals / Kit No.
N	Nitrile, Buna-N / (SK30523N-1)
V	Fluorocarbon / (SK30523V-1)

Code	Porting
815	1/4" SAE
816	1/4" BSP

Code	Body Material
A	Aluminum
S	Steel

- CV** Check Valves
- SH** Shuttle Valves
- LM** Load/Motor Controls
- FC** Flow Controls
- PC** Pressure Controls
- LE** Logic Elements
- DC** Directional Controls
- MV** Manual Valves
- SV** Solenoid Valves
- PV** Proportional Valves
- CE** Coils & Electronics
- BC** Bodies & Cavities
- TD** Technical Data

Technical Information

- CV Check Valves
- SH Shuttle Valves
- LM Load/Motor Controls
- FC Flow Controls
- PC Pressure Controls
- LE Logic Elements
- DC Directional Controls
- MV Manual Valves
- SV Solenoid Valves
- PV Proportional Valves
- CE Coils & Electronics
- BC Bodies & Cavities
- TD Technical Data

General Description

Poppet Type, Two Position, Three Way Shuttle Valve. For additional information see Technical Tips on pages SH1-SH2.

Features

- High flow capacity
- Compact cost effective design
- Poppet type construction for minimal leakage
- Contamination tolerant
- All external parts zinc plated

Performance Curve

Pressure Drop vs. Flow (Through cartridge only)

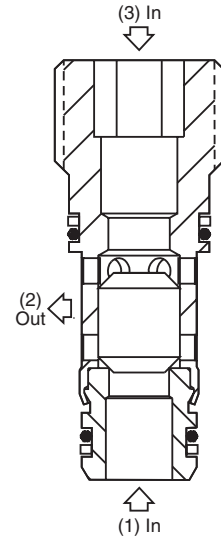
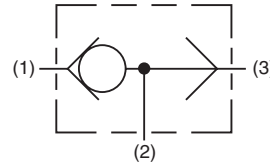
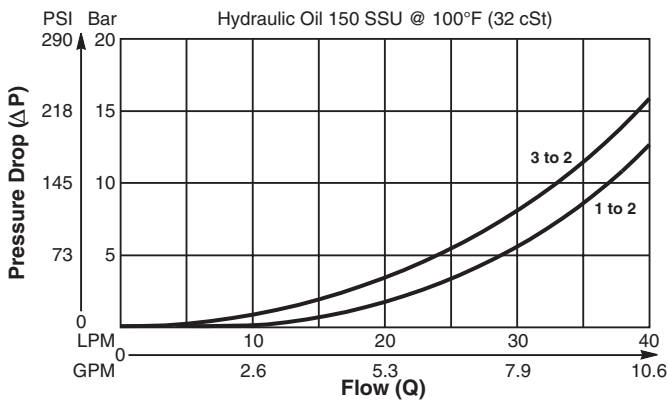

Dimensions Millimeters (Inches)

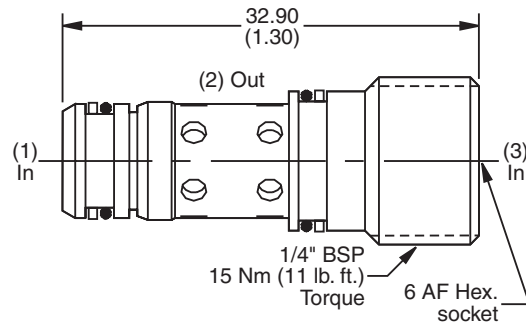

Specifications

Rated Flow	38 LPM (10 GPM)
Nominal Flow @ 7 Bar (100 PSI)	28 LPM (7.4 GPM)
Maximum Inlet Pressure	350 Bar (5000 PSI)
Cartridge Material	Steel operating parts, hardened steel poppet.
Operating Temp. Range/Seals	-40°C to +93.3°C (Nitrile, Buna-N) (-40°F to +200°F) -31.7°C to +121.1°C (Fluorocarbon) (-25°F to +250°F)
Fluid Compatibility/Viscosity	Mineral-based or synthetic with lubricating properties at viscosities of 45 to 2000 SSU (6 to 420 cSt)
Filtration	ISO code 16/13, SAE Class 4 or better
Approx. Weight	.02 kg (.04 lbs.)
Cavity	3Z (See BC Section for more details)

Application

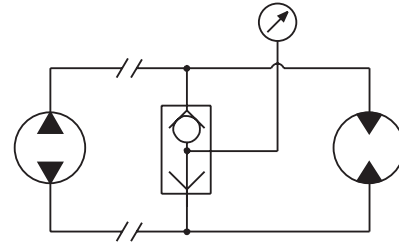

Selects highest pressure from either line.

Ordering Information

K2A005 Shuttle Valve Seals

Code	Seals / Kit No.
N	Nitrile, Buna-N / (SK30091N-1)
V	Fluorocarbon / (SK30091V-1)

Order Bodies Separately

LB10

Line Body Porting Body Material

Code	Porting
313	1/4" BSP
320	1/4" SAE

Code	Body Material
A	Aluminum
S	Steel



Technical Information

General Description

Cartridge Style Shuttle Valve. For additional information see Technical Tips on pages SH1-SH2.

Features

- Hardened, precision ground parts for durability
- Rapid response to load direction changes
- All external parts zinc plated

Performance Curve

Pressure Drop vs. Flow (Through cartridge only)

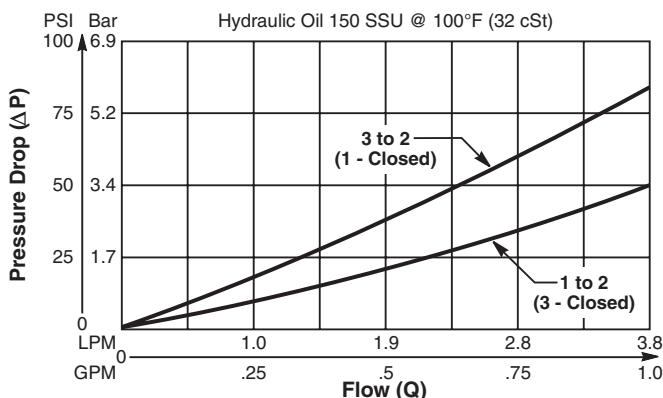

Specifications

Rated Flow	3.8 LPM (1 GPM)
Nominal Flow @ 7 Bar (100 PSI)	
Maximum Inlet Pressure	207 Bar (3000 PSI)
Leakage at 150 SSU (32 cSt)	5 drops/min. (.33 cc/min.) at 207 Bar (3000 PSI)
Cartridge Material	All parts steel. All operating parts hardened steel.
Operating Temp. Range/Seals	-40°C to +93.3°C (Nitrile) (-40°F to +200°F) -31.7°C to +121.1°C (Fluorocarbon) (-25°F to +250°F)
Fluid Compatibility/Viscosity	Mineral-based or synthetic with lubricating properties at viscosities of 45 to 2000 SSU (6 to 420 cSt)
Filtration	ISO code 16/13, SAE Class 4 or better
Approx. Weight	.02 kg (.04 lbs.)
Cavity	C04-3 (See BC Section for more details)
Form Tool	Rougher NFT04-3R Finisher NFT04-3F

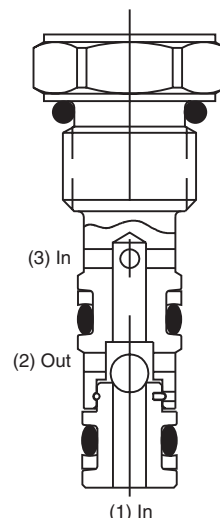
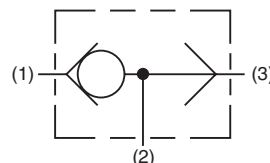

Dimensions Millimeters (Inches)

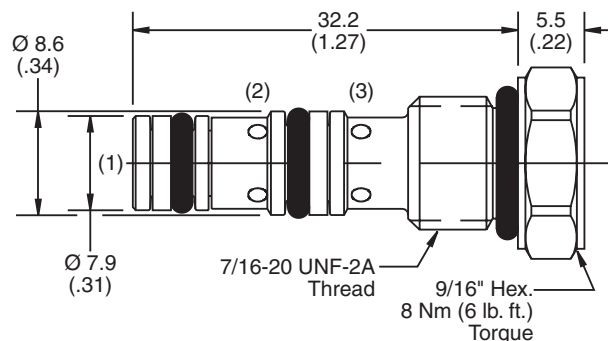

Ordering Information



Code	Seals / Kit No.
Omit	Nitrile / (SK03-3)
V	Fluorocarbon / (SK04-3V)

Code	Port Size	Body Part No.
Omit		Cartridge Only
A4T	SAE-4	(B04-3-A4T)

- CV** Check Valves
- SH** Shuttle Valves
- LM** Load/Motor Controls
- FC** Flow Controls
- PC** Pressure Controls
- LE** Logic Elements
- DC** Directional Controls
- MV** Manual Valves
- SV** Solenoid Valves
- PV** Proportional Valves
- CE** Coils & Electronics
- BC** Bodies & Cavities
- TD** Technical Data

Technical Information

- CV** Check Valves
- SH** Shuttle Valves
- LM** Load/Motor Controls
- FC** Flow Controls
- PC** Pressure Controls
- LE** Logic Elements
- DC** Directional Controls
- MV** Manual Valves
- SV** Solenoid Valves
- PV** Proportional Valves
- CE** Coils & Electronics
- BC** Bodies & Cavities
- TD** Technical Data

General Description

Ball Type, Two Position, Three Way Shuttle Valve. For additional information see Technical Tips on pages SH1-SH2.

Features

- High flow capacity
- Ball type construction for maximum wear resistance and greater durability
- Minimal leakage - less than 3 drops/min.
- Contamination tolerant
- All external parts zinc plated

Performance Curve

Pressure Drop vs. Flow (Through cartridge only)

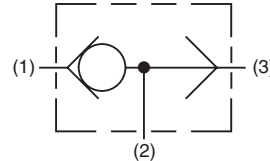
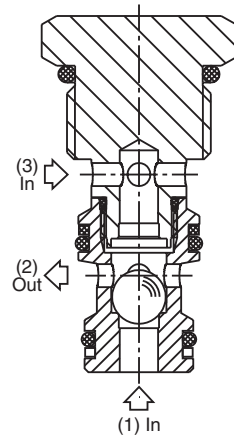
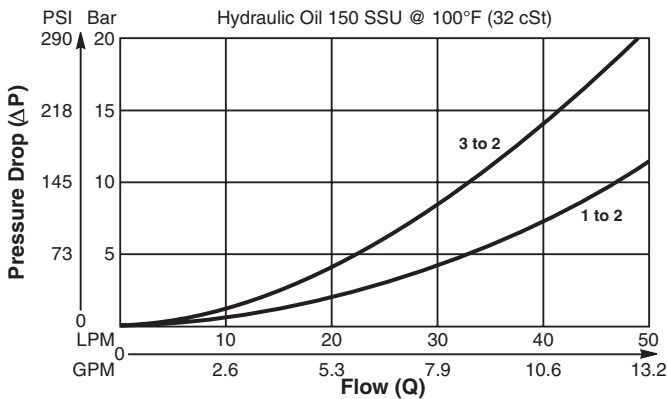

Dimensions Millimeters (Inches)

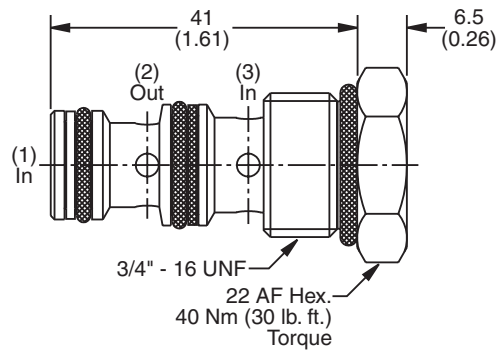

Specifications

Rated Flow	50 LPM (13 GPM)
Nominal Flow @ 7 Bar (100 PSI)	27 LPM (7 GPM)
Maximum Inlet Pressure	420 Bar (6000 PSI)
Cartridge Material	Steel operating parts, hardened steel poppet.
Operating Temp. Range/Seals	-40°C to +93.3°C (Nitrile, Buna-N) (-40°F to +200°F) -31.7°C to +121.1°C (Fluorocarbon) (-25°F to +250°F)
Fluid Compatibility/Viscosity	Mineral-based or synthetic with lubricating properties at viscosities of 45 to 2000 SSU (6 to 420 cSt)
Filtration	ISO code 16/13, SAE Class 4 or better
Approx. Weight	.07 kg (.15 lbs.)
Cavity	C08-3 (See BC Section for more details)

Application

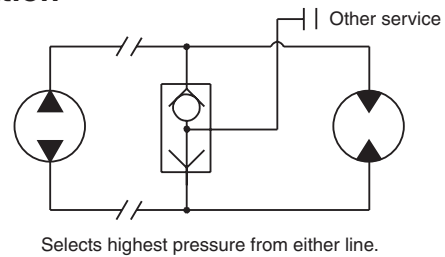

Ordering Information

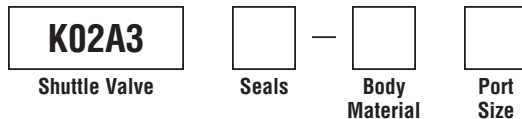

Code	Seals / Kit No.
N	Nitrile, Buna-N / (SK30521N-1)
V	Fluorocarbon / (SK30521V-1)

Code	Body Material
Omit	Steel
A	Aluminum

Code	Port Size	Body Part No.
Omit		Cartridge Only
4P	1/4" NPTF	(B08-3-*4P)
4T	SAE-4	(B08-3-*4T)
6T	SAE-6	(B08-3-*6T)
6B	3/8" BSPG	(B08-3-*6B)

* Add "A" for aluminum, omit for steel.

Technical Information

General Description

Cartridge Style Shuttle Valve. For additional information see Technical Tips on pages SH1-SH2.

Features

- Hardened, precision ground parts for durability
- 5000 PSI rated
- All external parts zinc plated

Performance Curve

Pressure Drop vs. Flow (Through cartridge only)

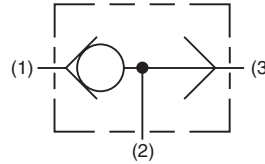
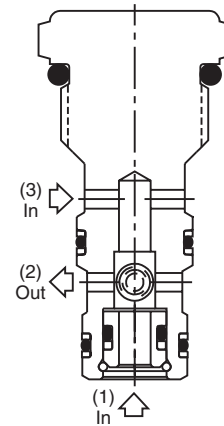
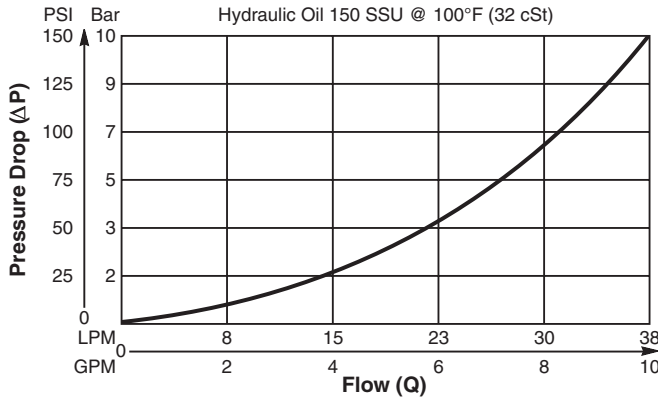

Dimensions Millimeters (Inches)

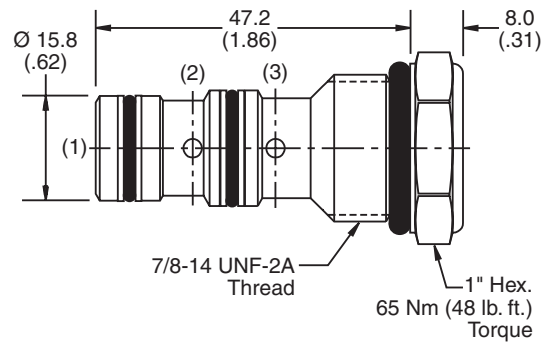

Specifications

Rated Flow	38 LPM (10 GPM)
Maximum Inlet Pressure	350 Bar (5000 PSI)
Leakage at 150 SSU (32 cSt)	10 drops/min. (.67 cc/min.) at 350 Bar (5000 PSI)
Cartridge Material	All parts steel. All operating parts hardened steel.
Operating Temp. Range/Seals	-40°C to +93.3°C (Nitrile) (-40°F to +200°F) -31.7°C to +121.1°C (Fluorocarbon) (-25°F to +250°F)
Fluid Compatibility/Viscosity	Mineral-based or synthetic with lubricating properties at viscosities of 45 to 2000 SSU (6 to 420 cSt)
Filtration	ISO code 16/13, SAE Class 4 or better
Approx. Weight	.14 kg (0.3 lbs.)
Cavity	C10-3 (See BC Section for more details)
Form Tool	Rougher NFT10-3R Finisher NFT10-3F

Ordering Information

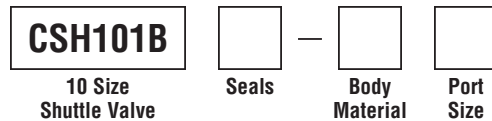

Code	Seals / Kit No.
Omit	Nitrile / (SK10-3N)
V	Fluorocarbon / (SK10-3V)

Code	Body Material
Omit	Steel
A	Aluminum

Code	Port Size	Body Part No.
Omit	Cartridge Only	
4P	1/4" NPTF	(B10-3-*4P)
6P	3/8" NPTF	(B10-3-*6P)
8P	1/2" NPTF	(B10-3-*8P)
6T	SAE-6	(B10-3-*6T)
8T	SAE-8	(B10-3-*8T)
6B	3/8" BSPG	(B10-3-6B)†
8B	1/2" BSPG	(B10-3-*8B)

* Add "A" for aluminum, omit for steel.
† Steel body only.

- CV Check Valves
- SH Shuttle Valves
- LM Load/Motor Controls
- FC Flow Controls
- PC Pressure Controls
- LE Logic Elements
- DC Directional Controls
- MV Manual Valves
- SV Solenoid Valves
- PV Proportional Valves
- CE Coils & Electronics
- BC Bodies & Cavities
- TD Technical Data

Technical Information

- CV Check Valves
- SH Shuttle Valves
- LM Load/Motor Controls
- FC Flow Controls
- PC Pressure Controls
- LE Logic Elements
- DC Directional Controls
- MV Manual Valves
- SV Solenoid Valves
- PV Proportional Valves
- CE Coils & Electronics
- BC Bodies & Cavities
- TD Technical Data

General Description

In-Line Style Shuttle Valve. For additional information see Technical Tips on pages SH1-SH2.

Features

- Compact in size
- In-line mounting
- Easily adaptable to various applications
- All external parts zinc plated

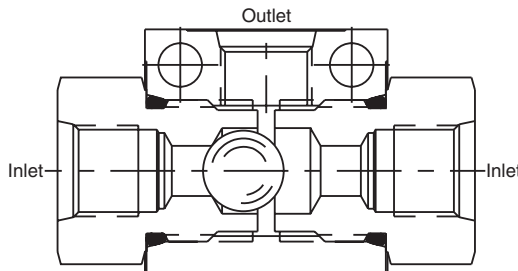
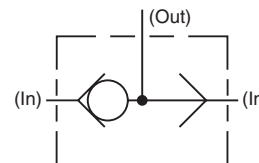
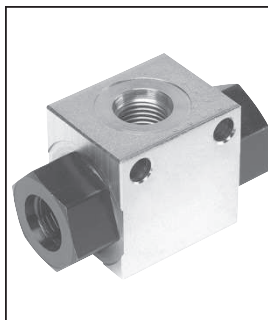

Specifications

Rated Flow	ASH-04-3 11 LPM (3 GPM) ASH-06-2 22 LPM (6 GPM)
Maximum Inlet Pressure	207 Bar (3000 PSI)
Leakage at 150 SSU (32 cSt)	5 drops/min. (.33 cc/min.) at 172 Bar (2500 PSI)
Body Material	Steel (Chromate Plated)
Operating Temp. Range/Seals	-40°C to +93.3°C (-40°F to +200°F) (Nitrile Seals Only)
Fluid Compatibility/Viscosity	Mineral-based or synthetic with lubricating properties at viscosities of 45 to 2000 SSU (6 to 420 cSt)
Filtration	ISO code 16/13, SAE Class 4 or better
Approx. Weight	ASH-04-3 .36 kg (0.8 lbs.) ASH-06-2 .45 kg (1.0 lbs.)

Performance Curves

Flow vs. Pressure Drop (Through cartridge only)

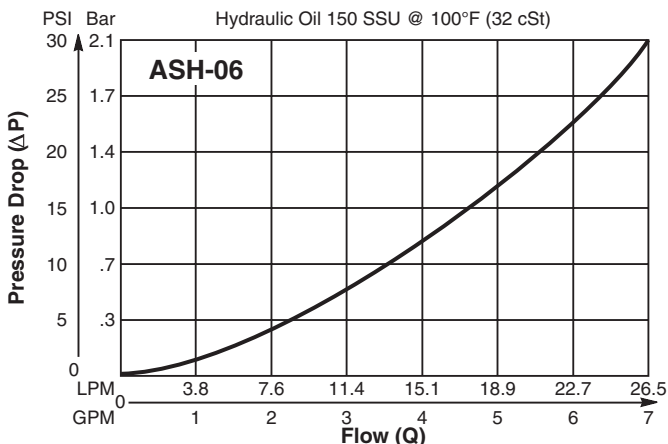
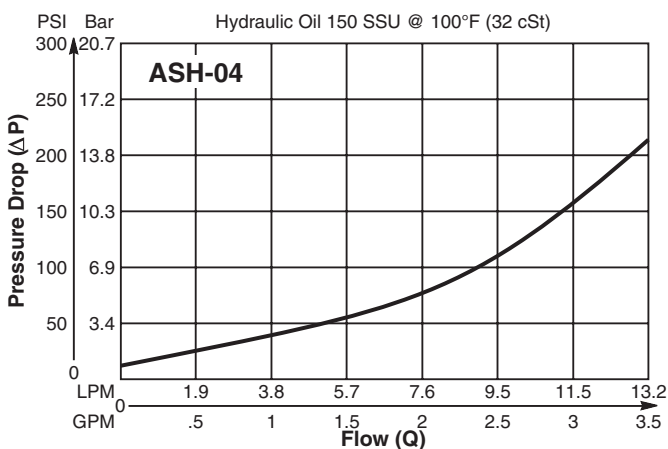

Technical Information

Dimensions Millimeters (Inches)

ASH-04-3

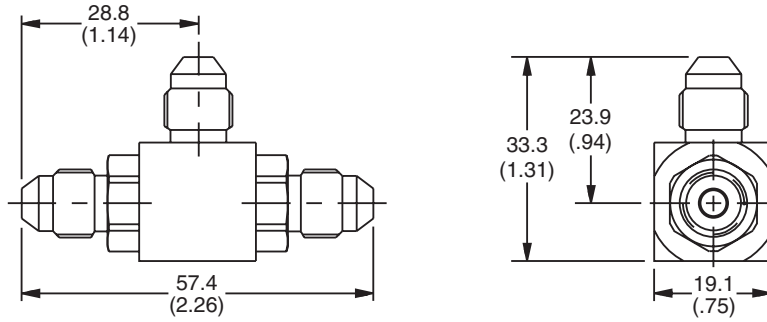

ASH-06-2

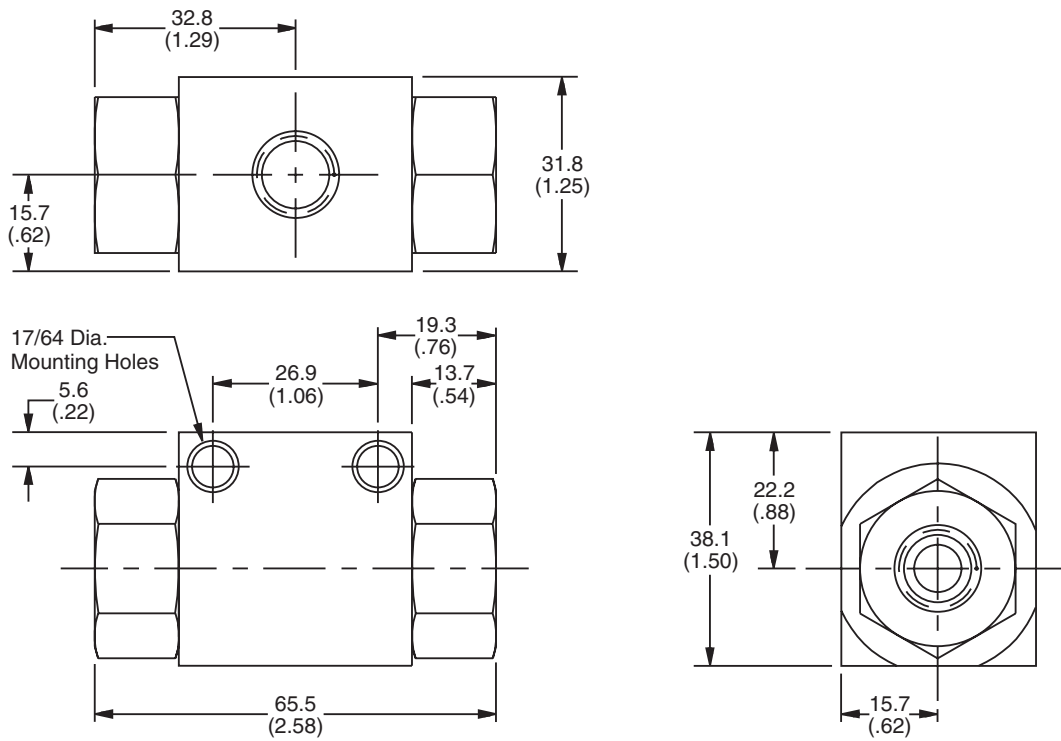

Ordering Information

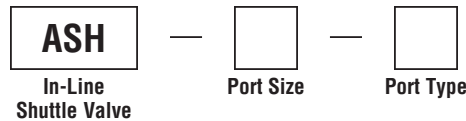

Code	Port Size
04	1/4" JIC
06	SAE-6

Code	Port Type
2	SAE (#6)
3	Male JIC (1/4" only)

- CV
Check Valves
- SH
Shuttle Valves
- LM
Load/Motor Controls
- FC
Flow Controls
- PC
Pressure Controls
- LE
Logic Elements
- DC
Directional Controls
- MV
Manual Valves
- SV
Solenoid Valves
- PV
Proportional Valves
- CE
Coils & Electronics
- BC
Bodies & Cavities
- TD
Technical Data

Technical Information

- CV** Check Valves
- SH** Shuttle Valves
- LM** Load/Motor Controls
- FC** Flow Controls
- PC** Pressure Controls
- LE** Logic Elements
- DC** Directional Controls
- MV** Manual Valves
- SV** Solenoid Valves
- PV** Proportional Valves
- CE** Coils & Electronics
- BC** Bodies & Cavities
- TD** Technical Data

General Description

Two Position, Three Way, Spring Offset Shuttle Valve. For additional information see Technical Tips on pages SH1-SH2.

Features

- High flow capacity
- Various switching pressures available
- Used as automatic brake release valve on motors, where brake release is required at pressures between 1 & 10 bar.
- Hardened working parts for maximum durability
- All external parts zinc plated

Performance Curve

Pressure Drop vs. Flow (Through cartridge only)

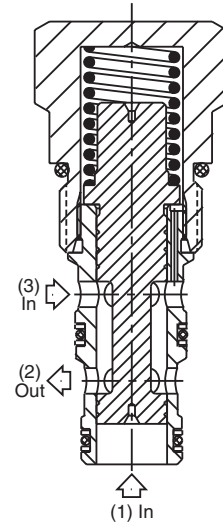
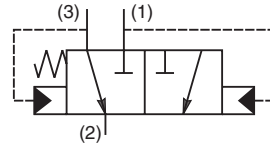
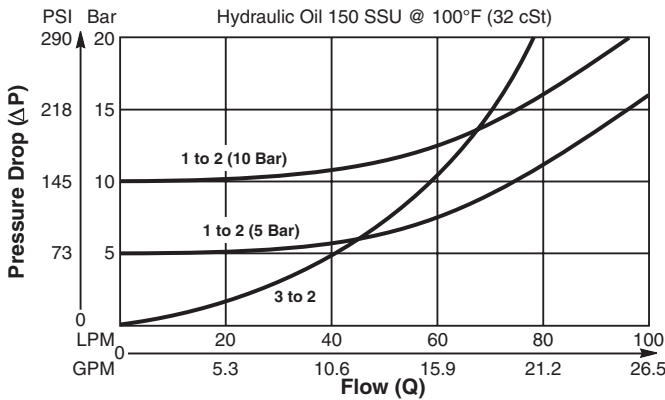

Dimensions Millimeters (Inches)

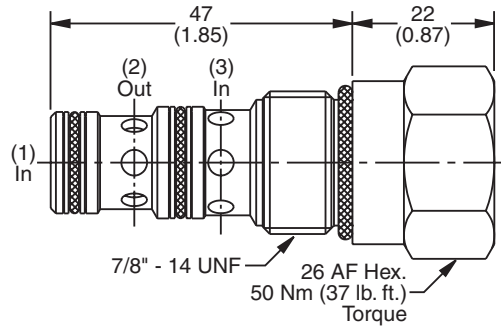

Specifications

Rated Flow	90 LPM (24 GPM)
Nominal Flow @ 7 Bar (100 PSI)	50 LPM (13 GPM)
Maximum Inlet Pressure	420 Bar (6000 PSI)
Cartridge Material	All parts steel. All operating parts hardened steel.
Operating Temp. Range/Seals	-40°C to +93.3°C (Nitrile, Buna-N) (-40°F to +200°F) -31.7°C to +121.1°C (Fluorocarbon) (-25°F to +250°F)
Fluid Compatibility/Viscosity	Mineral-based or synthetic with lubricating properties at viscosities of 45 to 2000 SSU (6 to 420 cSt)
Filtration	ISO code 16/13, SAE Class 4 or better
Approx. Weight	.14 kg (.31 lbs.)
Cavity	C10-3 (See BC Section for more details)

Application

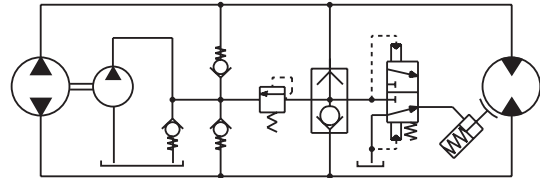

Brake release at various switching pressures.

Ordering Information

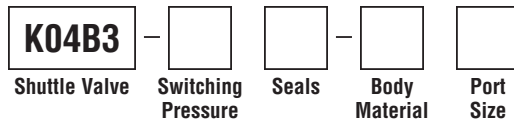

Code	Switching Pressure
5.0	5.0 Bar (73 PSI) Std.
10.0	10.0 Bar (145 PSI)

Code	Seals / Kit No.
N	Nitrile, Buna-N / (SK30505N-1)
V	Fluorocarbon / (SK30505V-1)

Code	Body Material
Omit	Steel
A	Aluminum

Code	Port Size	Body Part No.
Omit	Cartridge Only	
4P	1/4" NPTF	(B10-3-*4P)
6P	3/8" NPTF	(B10-3-*6P)
8P	1/2" NPTF	(B10-3-*8P)
6T	SAE-6	(B10-3-*6T)
8T	SAE-8	(B10-3-*8T)
6B	3/8" BSPG	(B10-3-6B)†
8B	1/2" BSPG	(B10-3-*8B)

* Add "A" for aluminum, omit for steel.
† Steel bodies only.

Technical Information

General Description

Two Position, Three Way Shuttle Valve.
For additional information see Technical Tips on pages SH1-SH2.

Features

- High flow capacity
- Used as automatic brake release valve on motors
- Hardened working parts for maximum durability
- All external parts zinc plated

Performance Curve

Pressure Drop vs. Flow (Through cartridge only)

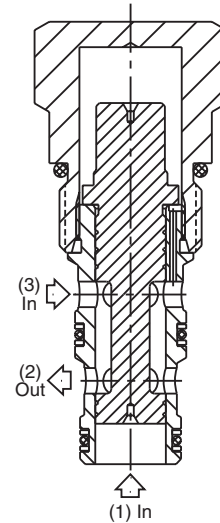
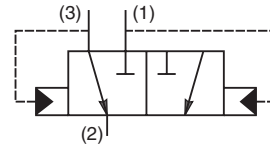
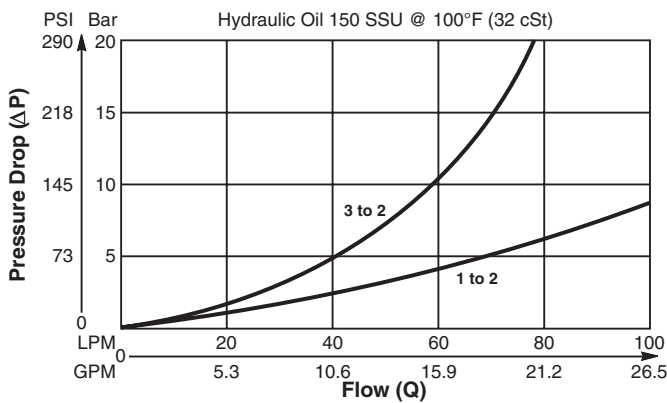

Dimensions Millimeters (Inches)

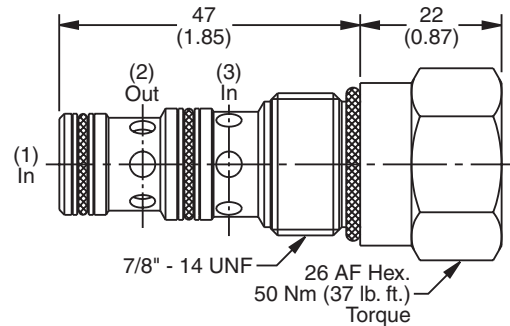

Specifications

Rated Flow	90 LPM (24 GPM)
Nominal Flow @ 7 Bar (100 PSI)	50 LPM (13 GPM)
Maximum Inlet Pressure	420 Bar (6000 PSI)
Cartridge Material	All parts steel. All operating parts hardened steel.
Operating Temp. Range/Seals	-40°C to +93.3°C (Nitrile, Buna-N) (-40°F to +200°F) -31.7°C to +121.1°C (Fluorocarbon) (-25°F to +250°F)
Fluid Compatibility/Viscosity	Mineral-based or synthetic with lubricating properties at viscosities of 45 to 2000 SSU (6 to 420 cSt)
Filtration	ISO code 16/13, SAE Class 4 or better
Approx. Weight	.14 kg (.31 lbs.)
Cavity	C10-3 (See BC Section for more details)

Application

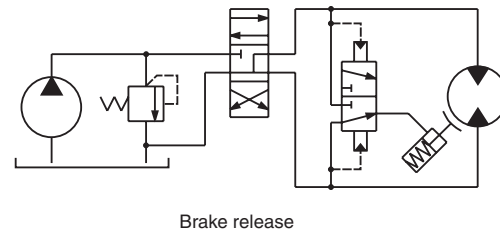

Ordering Information

K04D3 Shuttle Valve	Seals	Body Material	Port Size
Code Seals / Kit No.	Code Port Size	Code Body Part No.	
N Nitrile, Buna-N / (SK30505N-1)	4P 1/4" NPTF (B10-3-*4P)	Omit Cartridge Only	
V Fluorocarbon / (SK30505V-1)	6P 3/8" NPTF (B10-3-*6P)	6T SAE-6 (B10-3-*6T)	
	8P 1/2" NPTF (B10-3-*8P)	8T SAE-8 (B10-3-*8T)	
		6B 3/8" BSPG (B10-3-6B)†	
		8B 1/2" BSPG (B10-3-*8B)	
Code Body Material			
Omit Steel			
A Aluminum			

* Add "A" for aluminum, omit for steel.
† Steel bodies only.



CV Check Valves

SH Shuttle Valves

LM Load/Motor Controls

FC Flow Controls

PC Pressure Controls

LE Logic Elements

DC Directional Controls

MV Manual Valves

SV Solenoid Valves

PV Proportional Valves

CE Coils & Electronics

BC Bodies & Cavities

TD Technical Data

Technical Information

- CV Check Valves
- SH Shuttle Valves
- LM Load/Motor Controls
- FC Flow Controls
- PC Pressure Controls
- LE Logic Elements
- DC Directional Controls
- MV Manual Valves
- SV Solenoid Valves
- PV Proportional Valves
- CE Coils & Electronics
- BC Bodies & Cavities
- TD Technical Data

General Description

Two Position, Three Way, Spring Centered Shuttle Valve. For additional information see Technical Tips on pages SH1-SH2.

Features

- High flow capacity
- Various switching pressures available
- Use as purge valve in transmission systems
- Hardened working parts for maximum durability
- All external parts zinc plated

Performance Curve

Pressure Drop vs. Flow (Through cartridge only)

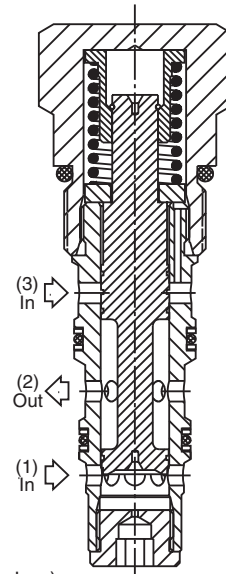
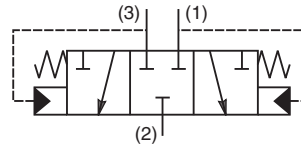
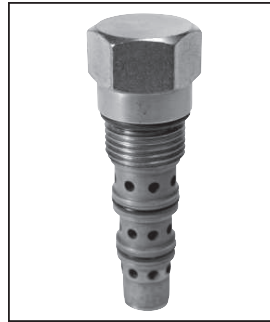
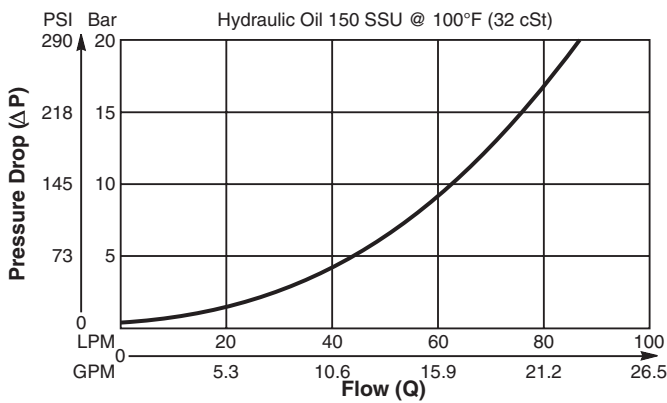

Dimensions Millimeters (Inches)

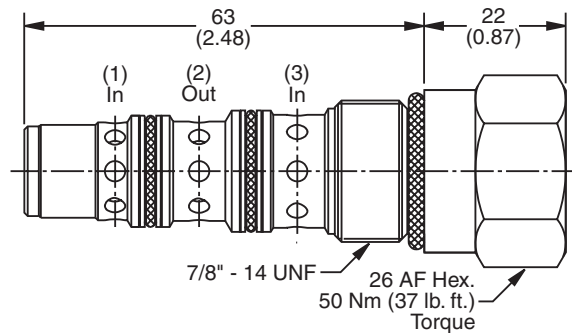

Specifications

Rated Flow	100 LPM (26 GPM)
Nominal Flow @ 7 Bar (100 PSI)	55 LPM (15 GPM)
Maximum Inlet Pressure	420 Bar (6000 PSI)
Cartridge Material	All parts steel. All operating parts hardened steel.
Operating Temp. Range/Seals	-40°C to +93.3°C (Nitrile, Buna-N) (-40°F to +200°F) -31.7°C to +121.1°C (Fluorocarbon) (-25°F to +250°F)
Fluid Compatibility/Viscosity	Mineral-based or synthetic with lubricating properties at viscosities of 45 to 2000 SSU (6 to 420 cSt)
Filtration	ISO code 16/13, SAE Class 4 or better
Approx. Weight	.17 kg (.37 lbs.)
Cavity	C10-4 (See BC Section for more details)

Application

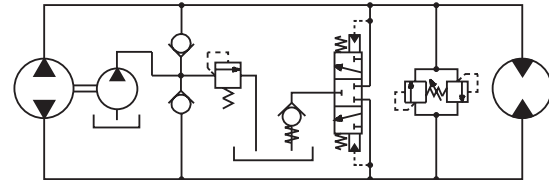

Purge valve in transmission circuit

Ordering Information

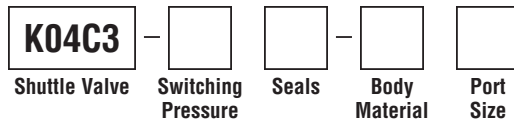

Code	Switching Pressure
0.0	0 Bar (0 PSI)
2.5	2.5 Bar (36 PSI)
5.0	5.0 Bar (73 PSI) Std.
10.0	10.0 Bar (145 PSI)
15.0	15.0 Bar (218 PSI)

Code	Body Material
Omit	Steel
A	Aluminum

Code	Seals / Kit No.
N	Nitrile, Buna-N / (SK30504N-1)
V	Fluorocarbon / (SK30504V-1)

Code	Port Size	Body Part No.
Omit	Cartridge Only	
6P	3/8" NTPF	(B10-4-*6P)
6T	SAE-6	(B10-4-*6T)
8T	SAE-8	(B10-4-*8T)
6B	3/8" BSPG	(B10-4-6B)†

* Add "A" for aluminum, omit for steel.
† Steel bodies only



Technical Information

General Description

Two Position, Three Way, Spring Centered Shuttle Valve. For additional information see Technical Tips on pages SH1-SH2.

Features

- High flow capacity
- Compact cost effective design
- Various spring options available
- Used in transmission systems as purge valve where hydraulic parking brake is necessary
- Hardened working parts for maximum durability
- All external parts zinc plated

Performance Curve

Pressure Drop vs. Flow (Through cartridge only)

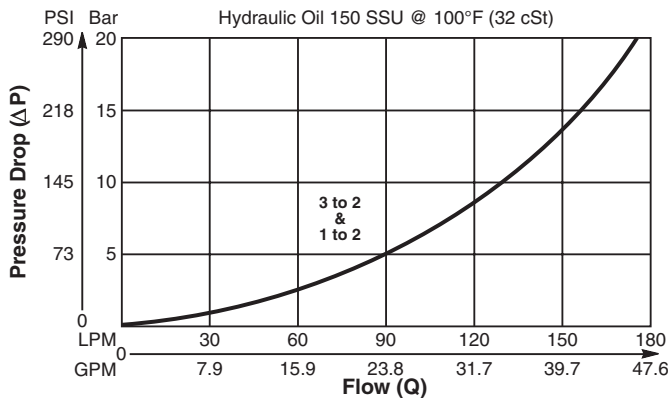

Specifications

Rated Flow	175 LPM (46 GPM)
Nominal Flow @ 7 Bar (100 PSI)	105 LPM (28 GPM)
Maximum Inlet Pressure	350 Bar (5000 PSI)
Cartridge Material	Steel operating parts, hardened steel poppet.
Operating Temp. Range/Seals	-40°C to +93.3°C (Nitrile, Buna-N) (-40°F to +200°F) -31.7°C to +121.1°C (Fluorocarbon) (-25°F to +250°F)
Fluid Compatibility/Viscosity	Mineral-based or synthetic with lubricating properties at viscosities of 45 to 2000 SSU (6 to 420 cSt)
Filtration	ISO code 16/13, SAE Class 4 or better
Approx. Weight	.32 kg (.70 lbs.)
Cavity	3U (See BC Section for more details)

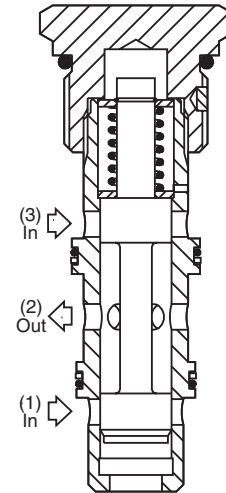
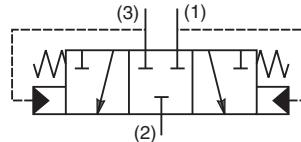
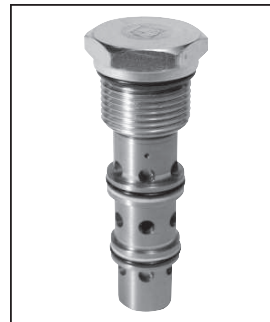

Dimensions Millimeters (Inches)

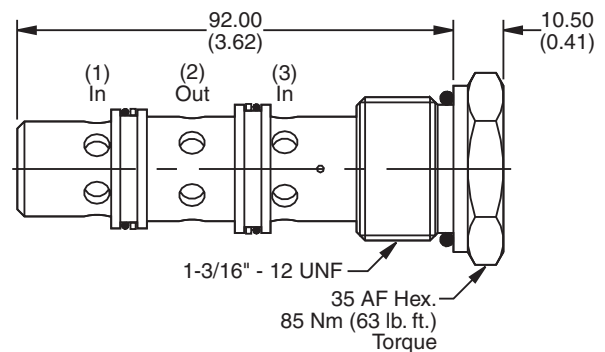

Application

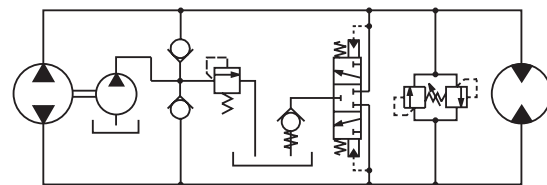

Purge valve in transmissions with hydraulic parking brake

Ordering Information

K3A125 —
Shuttle Valve Switching Pressure Seals

Code	Switching Pressure
1.0	1.0 Bar (15 PSI) Std.
9.0	9.0 Bar (130 PSI)

Code	Seals / Kit No.
N	Nitrile, Buna-N / (SK30040N-1)
V	Fluorocarbon / (SK30040V-1)

Order Bodies Separately

LB10
Line Body Porting Body Material

Code	Porting
092	3/4" BSP
093	1" SAE

Code	Body Material
A	Aluminum
S	Steel



CV
Check Valves

SH
Shuttle Valves

LM
Load/Motor Controls

FC
Flow Controls

PC
Pressure Controls

LE
Logic Elements

DC
Directional Controls

MV
Manual Valves

SV
Solenoid Valves

PV
Proportional Valves

CE
Coils & Electronics

BC
Bodies & Cavities

TD
Technical Data

Technical Information

- CV** Check Valves
- SH** Shuttle Valves
- LM** Load/Motor Controls
- FC** Flow Controls
- PC** Pressure Controls
- LE** Logic Elements
- DC** Directional Controls
- MV** Manual Valves
- SV** Solenoid Valves
- PV** Proportional Valves
- CE** Coils & Electronics
- BC** Bodies & Cavities
- TD** Technical Data

General Description

Two Position, Three Way, Spring Centered Shuttle Valve. For additional information see Technical Tips on pages SH1-SH2.

Features

- High flow capacity
- Various switching pressures available
- Hardened working parts for maximum durability
- All external parts zinc plated

Performance Curve

Pressure Drop vs. Flow (Through cartridge only)

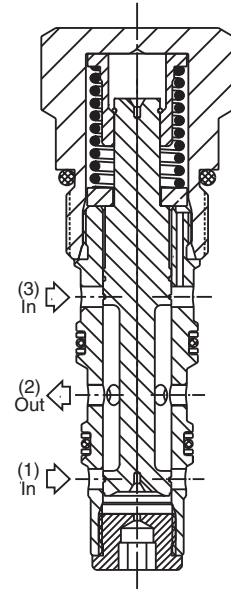
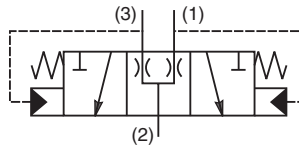
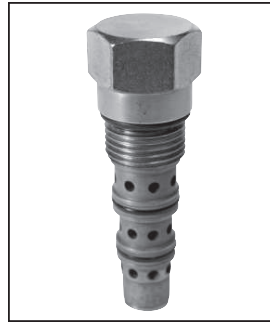
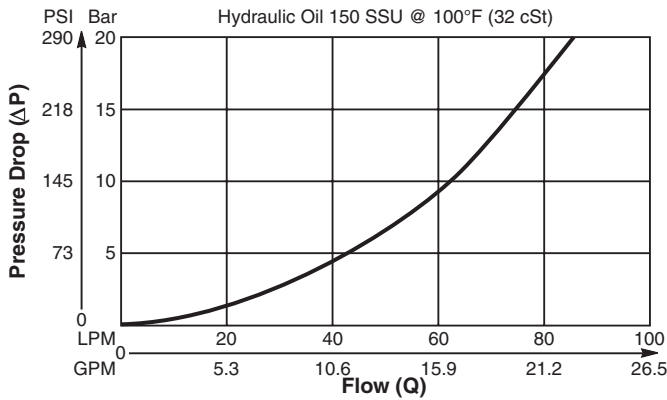

Dimensions Millimeters (Inches)

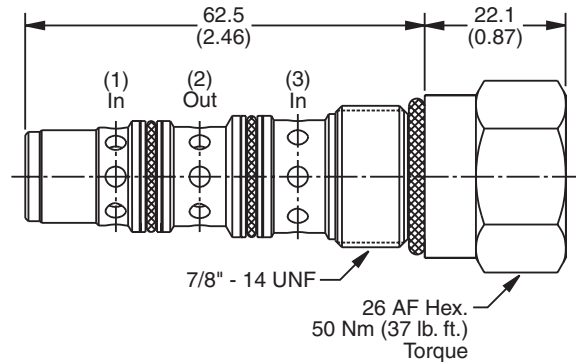

Specifications

Rated Flow	100 LPM (26 GPM)
Nominal Flow @ 7 Bar (100 PSI)	55 LPM (15 GPM)
Maximum Inlet Pressure	420 Bar (6000 PSI)
Cartridge Material	All parts steel. All operating parts hardened steel.
Operating Temp. Range/Seals	-40°C to +93.3°C (Nitrile, Buna-N) (-40°F to +200°F) -31.7°C to +121.1°C (Fluorocarbon) (-25°F to +250°F)
Fluid Compatibility/Viscosity	Mineral-based or synthetic with lubricating properties at viscosities of 45 to 2000 SSU (6 to 420 cSt)
Filtration	ISO code 16/13, SAE Class 4 or better
Approx. Weight	.17 kg (.37 lbs.)
Cavity	C10-4 (See BC Section for more details)

Ordering Information

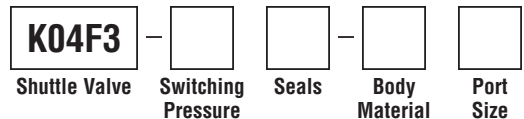

Code	Switching Pressure
0.0	0 Bar (0 PSI)
2.5	2.5 Bar (36 PSI)
5.0	5.0 Bar (73 PSI) Std.
10.0	10.0 Bar (145 PSI)
15.0	15.0 Bar (218 PSI)

Code	Body Material
Omit	Steel
A	Aluminum

Code	Seals / Kit No.
N	Nitrile, Buna-N / (SK30504N-1)
V	Fluorocarbon / (SK30504V-1)

Code	Port Size	Body Part No.
Omit	Cartridge Only	
6P	3/8" NTPF	(B10-4-*6P)
6T	SAE-6	(B10-4-*6T)
8T	SAE-8	(B10-4-*8T)
6B	3/8" BSPG	(B10-4-6B)†

* Add "A" for aluminum, omit for steel.
† Steel bodies only



General Description

Three Way, Ball Type, Spring Centered Inverse Shuttle Valve. For additional information see Technical Tips on pages SH1-SH2.

Features

- Used to ensure that in a dual accumulator charging circuit the accumulator with the lowest pressure is sensed back to the charging valve
- Suitable for charge rates up to 25 LPM (7 GPM) per accumulator
- One size valve for most applications
- All external parts zinc plated

Performance Curve

Pressure Drop vs. Flow (Through cartridge only)

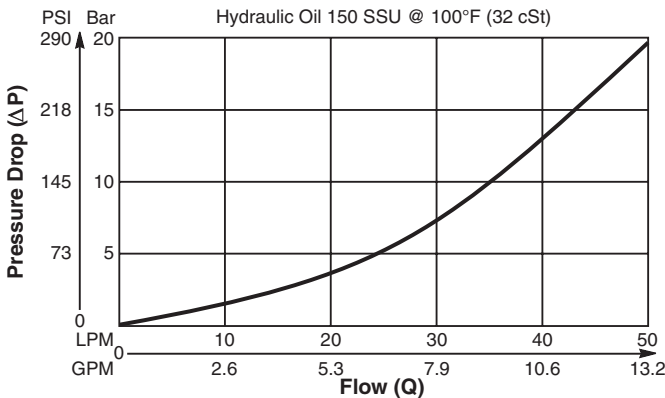

Specifications

Rated Flow	50 LPM (13.2 GPM)
Nominal Flow @ 7 Bar (100 PSI)	30 LPM (7.9 GPM)
Maximum Inlet Pressure	350 Bar (5000 PSI)
Cartridge Material	All parts steel. All operating parts hardened steel.
Operating Temp. Range/Seals	-40°C to +93.3°C (Nitrile, Buna-N) (-40°F to +200°F) -31.7°C to +121.1°C (Fluorocarbon) (-25°F to +250°F)
Fluid Compatibility/Viscosity	Mineral-based or synthetic with lubricating properties at viscosities of 45 to 2000 SSU (6 to 420 cSt)
Filtration	ISO code 16/13, SAE Class 4 or better
Approx. Weight	.14 kg (.31 lbs.)
Cavity	C10-4 (See BC Section for more details)

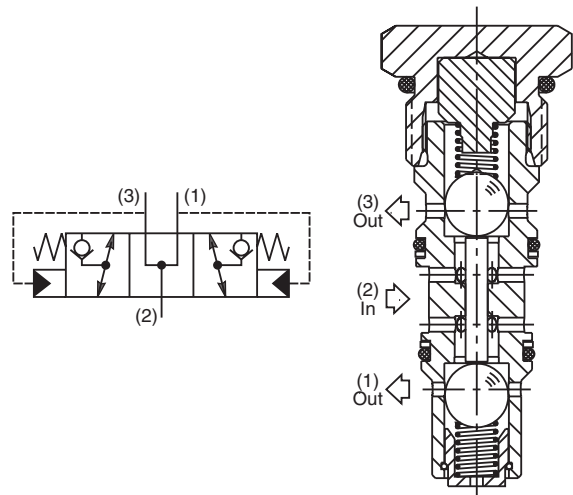

Dimensions Millimeters (Inches)

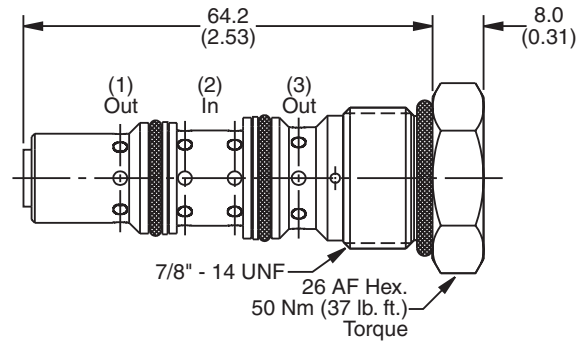

Application

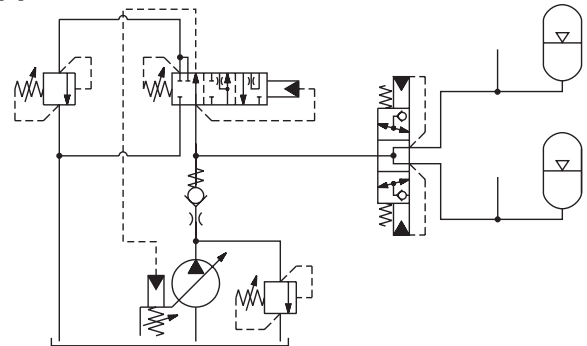

Ordering Information

K04G3	Seals	Body Material	Port Size
Code	Seals / Kit No.	Code	Port Size Body Part No.
N	Nitrile, Buna-N / (SK30534N-1)	Omit	Cartridge Only
V	Fluorocarbon / (SK30534V-1)	6P	3/8" NTPF (B10-4-*6P)
Code	Body Material	6T	SAE-6 (B10-4-*6T)
Omit	Steel	8T	SAE-8 (B10-4-*8T)
A	Aluminum	6B	3/8" BSPG (B10-4-6B)†

* Add "A" for aluminum, omit for steel.
 † Steel bodies only

CV Check Valves

SH Shuttle Valves

LM Load/Motor Controls

FC Flow Controls

PC Pressure Controls

LE Logic Elements

DC Directional Controls

MV Manual Valves

SV Solenoid Valves

PV Proportional Valves

CE Coils & Electronics

BC Bodies & Cavities

TD Technical Data

Contents

Solenoid Valves

CV Check Valves

SH Shuttle Valves

LM Load/Motor Controls

FC Flow Controls

PC Pressure Controls

LE Logic Elements

DC Directional Controls

MV Manual Valves

SV Solenoid Valves

PV Proportional Valves

CE Coils & Electronics

BC Bodies & Cavities

TD Technical Data

SERIES	CAVITY	DESCRIPTION	FLOW LPM/GPM	PRESSURE BAR/PSI	PAGE NO.
--------	--------	-------------	--------------	------------------	----------

HIGH FLOW VALVE FAMILY

See individual catalog pages for exact specifications.

2 WAY SPOOL TYPE

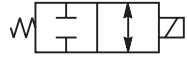

GS02 22* 2X / C09-2 .. 2 Position, 2 Way, N.C. Spool 19/5 350/5000 SV7-SV8



GS02 27* 2X / C09-2 .. 2 Position, 2 Way, N.O. Spool 19/5 350/5000 SV9-SV10

**These valves fit the C09-2 Parker cavity.*

4 WAY, 2 POSITION SPOOL TYPE



GS02 42 C08-4 2 Position, 4 Way 19/5 350/5000 SV11-SV12

2 WAY POPPET TYPE

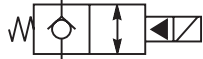

☆ DSL081 C08-2 2 Position, 2 Way, N.C. or N.O. 30/8 250/3600 SV13-SV14

☆ DSH081 C08-2 2 Position, 2 Way, N.C. or N.O. 30/8 350/5000 SV15-SV16

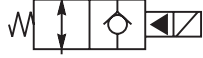

☆ DSL101 C10-2 2 Position, 2 Way, N.C. or N.O. 60/15 250/3600 SV17-SV18

☆ DSH101 C10-2 2 Position, 2 Way, N.C. or N.O. 60/15 350/5000 SV19-SV20

DSH121 C12-2 2 Position, 2 Way, N.C. or N.O. 90/24 350/5000 SV21-SV22

DS161 C16-2 2 Position, 2 Way, N.C. or N.O. 150/40 210/3000 SV23-SV24

☆ DSH161* C16-2 2 Position, 2 Way, N.C. or N.O. 150/40 350/5000 SV25-SV26

DS201 C20-2 2 Position, 2 Way, N.C. or N.O. 260/70 210/3000 SV27-SV28

☆ DSL201* C20-2 2 Position, 2 Way, N.C. or N.O. 260/70 250/3600 SV29-SV30

**The DSH161 and DSL201 will be available January 1, 2011*



GH02 01 C08-2 2 Position, 2 Way, N.C., with Flow Adj. 11/3 285/4000 SV31-SV32

GS02 72/73 C08-2 Bi-Directional Poppet, N.C. 1.7/45 210/3000 SV33-SV34

GS02 80*/81 C08-2 Bi-Directional Poppet, N.C. 58/15 350/5000 SV35-SV36



GS04 80*/81 2R Bi-Directional Poppet, N.C. 76/20 350/5000 SV37-SV38

GS06 80*/81 C16-2 Bi-Directional Poppet, N.C. 285/75 350/5000 SV39-SV40

GS02 77/78 C08-2 Bi-Directional Poppet, N.O. 1.7/45 210/3000 SV41-SV42

GS02 85*/86 C08-2 Bi-Directional Poppet, N.O. 58/15 350/5000 SV43-SV44

GS04 85*/86 2R Bi-Directional Poppet, N.O. 76/20 350/5000 SV45-SV46

GS06 85*/86 C16-2 Bi-Directional Poppet, N.O. 285/75 350/5000 SV47-SV48

**210/3000 psi rating*

☆ Denotes New Winner's Circle Product Line.



	SERIES	CAVITY	DESCRIPTION	FLOW LPM/GPM	PRESSURE BAR/PSI	PAGE NO.
2 WAY SPOOL TYPE						
	☆ DSL082	C08-2	2 Position, 2 Way	15/4	250/3600	SV49-SV50
	☆ DSH082	C08-2	2 Position, 2 Way	15/4	350/5000	SV51-SV52
	☆ DSL102	C10-2	2 Position, 2 Way	30/8	250/3600	SV53-SV54
	☆ DSH102	C10-2	2 Position, 2 Way	30/8	350/5000	SV55-SV56
	DS162	C16-2	2 Position, 2 Way	75/20	210/3000	SV57-SV58
3 WAY SPOOL TYPE						
	☆ DSL083	C08-3	2 Position, 3 Way	15/4	250/3600	SV59-SV61
	☆ DSH083	C08-3	2 Position, 3 Way	15/4	350/5000	SV62-SV64
	☆ DSL103	C10-3	2 Position, 3 Way	30/8	250/3600	SV65-SV67
	☆ DSH103	C10-3	2 Position, 3 Way	30/8	350/5000	SV68-SV70
	DS163	C16-3	2 Position, 3 Way	57/15	210/3000	SV71-SV72
4 WAY, 2 POSITION SPOOL TYPE						
	☆ DSL084	C08-4	2 Position, 4 Way	15/4	250/3600	SV73-SV74
	☆ DSH084	C08-4	2 Position, 4 Way	15/4	350/5000	SV75-SV76
	☆ DSL104	C10-4	2 Position, 4 Way	30/8	250/3600	SV77-SV78
	☆ DSH104	C10-4	2 Position, 4 Way	30/8	350/5000	SV79-SV80
	DSH164	C16-4	2 Position, 4 Way	113/30	350/5000	SV81-SV82
4 WAY, 3 POSITION SPOOL TYPE						
	GS02 51	C08-4	3 Position, 4 Way	17/4.5	350/5000	SV83-SV84
	GS02 53	C08-4	3 Position, 4 Way	15/4	350/5000	SV85-SV86
	GS02 57	C08-4	3 Position, 4 Way	13/3.5	350/5000	SV87-SV88
	GS02 59	C08-4	3 Position, 4 Way	13/3.5	350/5000	SV89-SV90
	☆ DSL105	C10-4	3 Position, 4 Way	19/5	250/3600	SV91-SV92
	GS04 52D	C10-4	3 Position, 4 Way	20/8	350/5000	SV93-SV94
	GS04 54D	C10-4	3 Position, 4 Way	38/10	350/5000	SV95-SV96
	GS04 57D	C10-4	3 Position, 4 Way	42/11	350/5000	SV97-SV98
	GS04 59D	C10-4	3 Position, 4 Way	42/11	350/5000	SV99-SV100
	DSH125 52	C12-4L	3 Position, 4 Way	57/15	350/5000	SV101-SV102
	DSH125 54	C12-4L	3 Position, 4 Way	57/15	350/5000	SV103-SV104
	DSH125 57	C12-4L	3 Position, 4 Way	57/15	350/5000	SV105-SV106
	DSH125 59	C12-4L	3 Position, 4 Way	57/15	350/5000	SV107-SV108

- CV**
Check Valves
- SH**
Shuttle Valves
- LM**
Load/Motor Controls
- FC**
Flow Controls
- PC**
Pressure Controls
- LE**
Logic Elements
- DC**
Directional Controls
- MV**
Manual Valves
- SV**
Solenoid Valves
- PV**
Proportional Valves
- CE**
Coils & Electronics
- BC**
Bodies & Cavities
- TD**
Technical Data

☆ Denotes New Winner's Circle Product Line.



CV

Check Valves

SH

Shuttle Valves

LM

Load/Motor Controls

FC

Flow Controls

PC

Pressure Controls

LE

Logic Elements

DC

Directional Controls

MV

Manual Valves

SV

Solenoid Valves

PV

Proportional Valves

CE

Coils & Electronics

BC

Bodies & Cavities

TD

Technical Data

INTRODUCTION

This technical tips section is designed to help familiarize you with the Parker line of Solenoid Valves. In this section we highlight new products to this catalog as well as some design features of our solenoid valves. In addition we present common options available to help you in selecting products for your application. Finally, we give a brief synopsis of the operation and applications of the various products offered in this section. Some tips in applying and selecting our products are provided throughout this guide.

NEW PRODUCTS

There are several new additions and product improvements to our Solenoid Valve product line.

Here are just some of the design features and advantages to the product line.

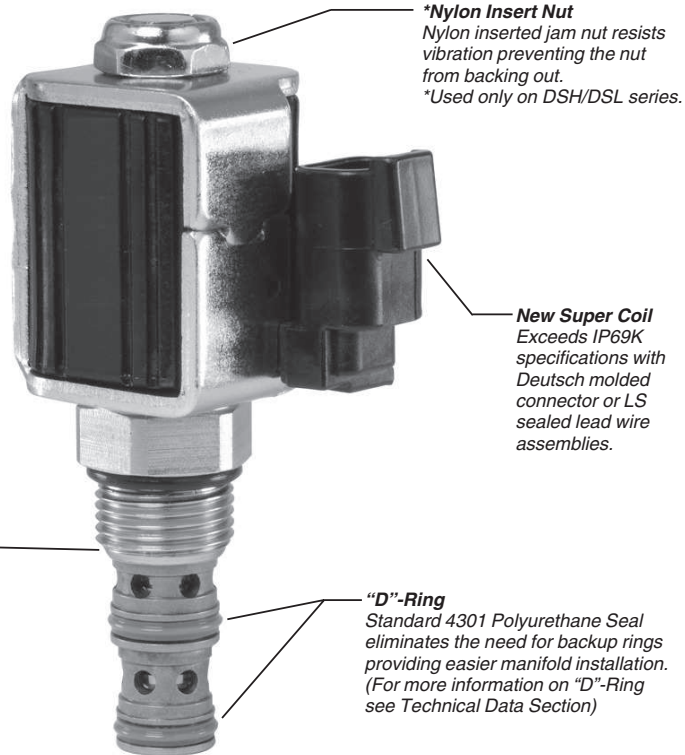

***Nylon Insert Nut**
Nylon inserted jam nut resists vibration preventing the nut from backing out.
**Used only on DSH/DSL series.*

New Super Coil
Exceeds IP69K specifications with Deutsch molded connector or LS sealed lead wire assemblies.

Crimp Design
Fold over crimp provides secure holding and eliminates the need for adhesive.

"D"-Ring
Standard 4301 Polyurethane Seal eliminates the need for backup rings providing easier manifold installation. (For more information on "D"-Ring see Technical Data Section)

New Parker SUPER COIL Now Available!

***Exceeds IP69k Specifications**

After exhaustive testing, the new Super Coil has clearly distanced itself from the competition. This coil was subjected to the rigors of this environmental standard and the results were excellent. This coil stands up to most rugged of environmental conditions including weather, dust, and extreme temperature variations.

***Water Dunk Test Qualified**

The Super Coil was taken to task in a repeated water dunk thermal cycle test program with alternate exposure to high and low temperature, only to perform with outstanding results.

***Endurance Tested**

The goal of this test was to cycle the coil to high temperature extremes in order to validate the coils ability to perform in extreme temperature environments.

***Water Spray and Chemical Solvent Compatibility**

The Super Coil was subjected to numerous chemical solvents in a rigorous test which established the fact that these coils can withstand harsh and unusual environments. Also, the coils were subjected to a high pressure water spray test. Once again, the Super Coil passed this test.

**Deutsch molded connector or LS option is highly recommended.*

NOTE: LS coil option will be available January 1, 2011.

COMMON OPTIONS

As you will see, Parker offers a variety of solenoid valve products. As such, some of the options mentioned below may not be available on all valves. Consult the model coding and dimensions for each valve for more specifics. Here are some of the common options available.

Seals: The Winner's Circle products feature a standard Polyurethane "D"-Ring. The "D"-Ring eliminates the need for backup rings. For more information on the "D"-Ring see the Technical Data section of the catalog. The majority of the products are available in Nitrile or Fluorocarbon Seals. You should always match the seal compatibility to the temperature and fluid being used in your application.

Coils: Coils can be ordered as part of the full assembly or separately. Various terminations and voltages are available. For detailed information on the coil options consult the coil section of the catalog. The ordering information for each valve will direct you to the proper coil.

Manual Overrides: Many of our solenoid valves are also offered with a manual override. The override allows the user to shift the valve when coil force is not available. They provide a means of shifting the solenoid valve due to a loss of power or a coil failure. Overrides are intended for infrequent usage and are not designed to be used as a primary method of valve actuation.

The most common override option for the 2 Position valves is the push & twist style shown below. With a normally closed valve or a pull style tube, the valve is in normal operation (or de-energized)

when the pin is seated in the slotted groove at the lowest position. To shift the valve manually, the operator pushes down on the knob and twists it counterclockwise. When the pressure is removed from the knob, an internal spring pushes the pin up the slotted groove to the upper position of the override. With a normally open valve, or push style tube, the actuation is reversed. The valve is in the normal position (or de-energized)

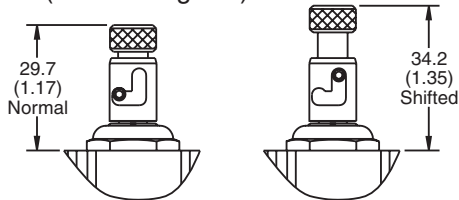

Normally Closed Pull Type Tube

when the pin is in the upper position of the override. To shift the valve manually, the operator pushes

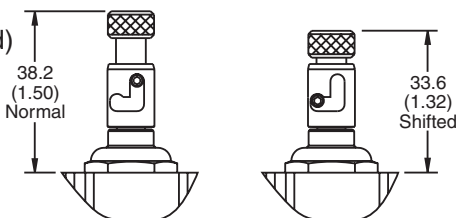

Normally Open Push Type Tube

down on the knob and twists is clockwise. Once the pin is seated in the slotted groove, the operator can remove pressure and the valve will stay actuated.

In addition to the push and twist style override, normally closed (pull style tube) 2 position valves can be ordered with a pull and release override. Normally open (push style) 2 position valves are available with flush style and extended style overrides. These overrides are not detented. Each style is shown below.

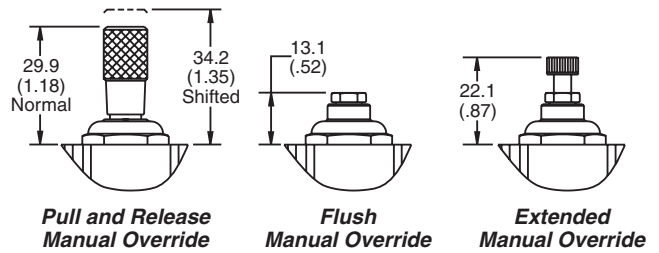

3 Position valves are offered with a Push / Pull style override. This override is not detented. Springs hold the spool of the valve in the center position of the valve. When the knob is pulled, the spool is moved upward simulating the action of the upper coil. When the override is pushed, the spool moves downward simulating the action of the lower coil. When no pressure is applied to the knob, it centers the spool.

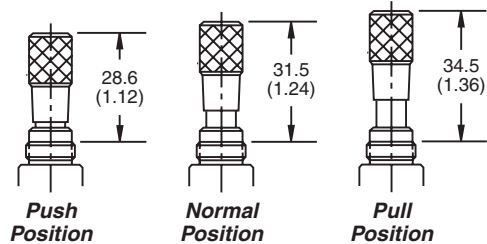

Screens: 2 way valves can be ordered with a small mesh screen (60 x 60 mesh) placed over the cage of the cartridge valve. This screen is intended for cursory protection of the internal components of the solenoid valve. It should not be used as the primary method of filtration. The mesh catches small pieces of debris that could impede spool or poppet movement. Note that a screen will trap debris from both directions. Thus, any debris coming from the nose of the cartridge would be trapped inside the valve. As such, we recommend that screens be implemented in only applications where hydraulic fluid passes through the cartridge from the side of the cage to the nose. It should also be noted that the pressure drop through the cartridge will be increased slightly due to the small restriction of the mesh. As the screen fills with debris, pressure drop will continue to rise.



- CV**
- Check Valves
- SH**
- Shuttle Valves
- LM**
- Load/Motor Controls
- FC**
- Flow Controls
- PC**
- Pressure Controls
- LE**
- Logic Elements
- DC**
- Directional Controls
- MV**
- Manual Valves
- SV**
- Solenoid Valves
- PV**
- Proportional Valves
- CE**
- Coils & Electronics
- BC**
- Bodies & Cavities
- TD**
- Technical Data

CV	Check Valves
SH	Shuttle Valves
LM	Load/Motor Controls
FC	Flow Controls
PC	Pressure Controls
LE	Logic Elements
DC	Directional Controls
MV	Manual Valves
SV	Solenoid Valves
PV	Proportional Valves
CE	Coils & Electronics
BC	Bodies & Cavities
TD	Technical Data

PRODUCT TYPES / APPLICATIONS

Two Way Poppet Valves

Two way poppet valves are pilot operated, low leakage solenoid actuated valves. Two way poppet valves control the flow of a two way function by blocking flow in one direction (similar to a check valve). They are generally selected due to their low leakage and ability to meet higher flow requirements. Poppet valves are often used on single operation actuators or in unloading functions. They are available in normally closed and normally open types. In addition, free reverse flow and fast response versions are available.

Normally Closed Poppet

Normally closed two way poppet valves act as a check valve when de-energized, blocking flow from one direction and allowing restricted free flow in the reverse condition. When energized, the poppet lifts allowing free flow from the side to the nose of the cartridge. Should the application require free flow in both directions, the free reverse flow option should be chosen.

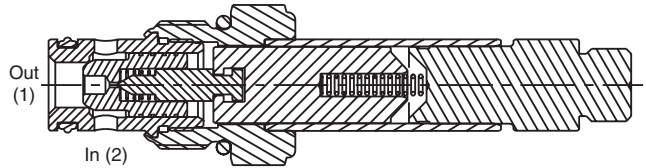
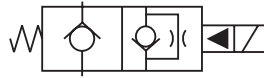

OPERATION - The valve pilot is held on its seat by spring force, blocking pilot flow. This allows pressure at the inlet (port 2) to hold the poppet on its seat, thus, preventing flow through the valve (2-1). If the nose of the cartridge (port 1) is pressurized, the pressure will overcome the spring force, pushing the poppet off of its seat, allowing free flow through the cartridge (1-2). When the coil is energized, the valve pilot is pulled off of its seat. This vents the pressure inside the poppet to port 1, creating a pressure imbalance across the main poppet. This differential lifts the poppet allowing flow from the side to nose (2-1). Since poppet valves are piloted operated, a minimum amount of pressure differential (25-50 psi) and flow between ports 2 and 1 must be present to overcome the spring and lift the poppet.

Normally Open Poppet

Normally open two way poppet valves, when de-energized, allow free flow from the side (port 2) of the cartridge to the nose (port 1). Flow in the reverse direction is restricted. Should free flow be required in both directions, the free reverse flow option should be specified. Once the coil is energized the normally open poppet valve acts as a check valve, blocking flow from one direction and allowing restricted free flow in the reverse condition.

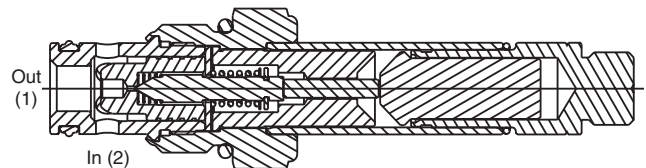
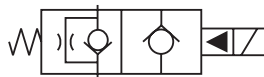

OPERATION - The valve pilot is held off its seat by spring force. Pilot flow is vented to port 1, creating a pressure imbalance that moves the main poppet. This differential lifts the poppet allowing flow from the side to nose (2-1). Since poppet valves are piloted operated, a minimum amount of pressure differential (25-50 psi) between ports 2 and 1 must be present to overcome the spring and lift the poppet. When the coil is energized, the coil force overcomes the spring force to drive the valve pilot and main poppet into their seats, thus blocking flow from port 2-1. If the nose of the cartridge (port 1) is pressurized, the pressure will overcome the spring force and solenoid force, pushing the poppet off of its seat, allowing restricted flow through the cartridge (1-2).

Free Reverse Flow

The free reverse flow versions are available on both the normally closed and normally open poppet valves. As mentioned above, the operation is the same as the standard poppet valve except flow through the reverse direction is not restricted. The free reverse flow option is only needed if the application requires flow to pass through the cartridge valve from the nose to side (port 1 to port 2).

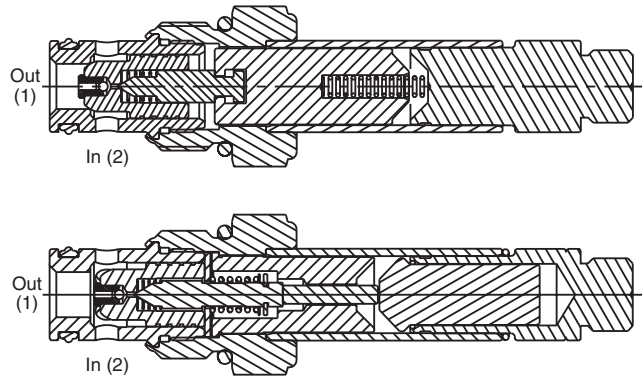
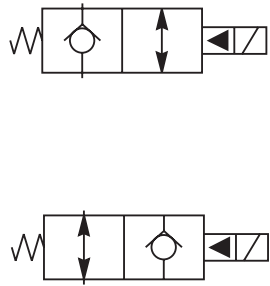

Fast Response

Since poppet valves are pilot operated valves, a few milliseconds are needed to move the pilot and allow the poppet to lift. Should a faster response time be required on normally closed poppet valves, this option can be chosen. The fast response is accomplished by reducing the movement of the pilot. Thus, the flow capacity of the poppet valve is also decreased.

Two Way Spool Valves

Two way spool valves are direct acting, fast responding solenoid actuated valves. Like the poppet valves described earlier, they block the flow of a two way function. Unlike two way poppet valves, spool valves block flow from both the side port and the nose port. They do not have the check like function of the poppet valve, thus they are either open or closed. Spool valves are directed operated, so they respond more quickly to coil voltage than poppet valves. Spool valves operate via a sliding spool, thus, some leakage will be present due to the required spool clearance. Spool valves block flow in both directions, but the preferred flow path is still from the side of the cartridge to the nose due to the flow forces acting on the spool. Two way spool valves are available in normally open and normally closed types.

Normally Closed Spool

When de-energized, the spool is positioned by the spring force to cover both the side (2) and nose (1) ports of the valve. Thus, no flow is allowed from either direction. Once the coil is energized, the spool shifts exposing a flow path between the two ports. Flow can then be passed through the valve from either direction.

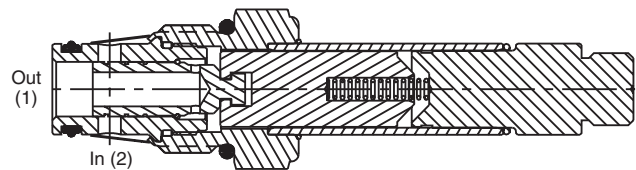

Normally Open Spool

When de-energized, the spool is positioned by the spring force so that a flow path between the side (2) and nose (1) ports is exposed, allowing flow through the valve from either direction. Once the coil is energized, the spool shifts to cover both the side (2) and nose (1) ports of the valve. Thus, no flow is allowed from either direction.

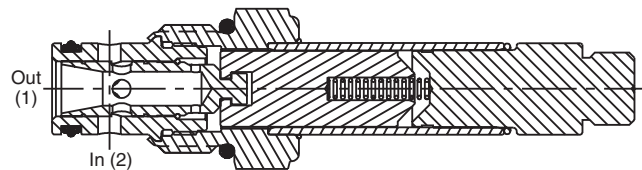

- CV**
Check Valves
- SH**
Shuttle Valves
- LM**
Load/Motor Controls
- FC**
Flow Controls
- PC**
Pressure Controls
- LE**
Logic Elements
- DC**
Directional Controls
- MV**
Manual Valves
- SV**
Solenoid Valves
- PV**
Proportional Valves
- CE**
Coils & Electronics
- BC**
Bodies & Cavities
- TD**
Technical Data

- CV** Check Valves
- SH** Shuttle Valves
- LM** Load/Motor Controls
- FC** Flow Controls
- PC** Pressure Controls
- LE** Logic Elements
- DC** Directional Controls
- MV** Manual Valves
- SV** Solenoid Valves
- PV** Proportional Valves
- CE** Coils & Electronics
- BC** Bodies & Cavities
- TD** Technical Data

Bi-Directional Poppet Valve

Bi-directional poppet valves combine the dual blocking function of spool valves with the lower leakage capabilities of poppet valves. These valves also have a limited flow capacity compared to standard poppet or spool valves.

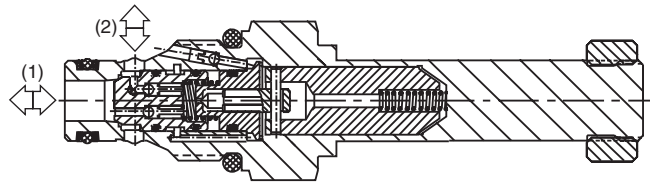
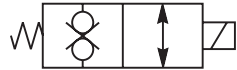

Two Position, Three Way Spool Valve

Three way spool solenoid valves provide directional control of flow. Each three way valve has a special internal spool which connects two of the three valve ports. When actuated, the spool connects a different combination of valve ports. These valves are often used for raise and lower functions of a single acting cylinder, control of a uni-directional motor, or as a circuit selector.

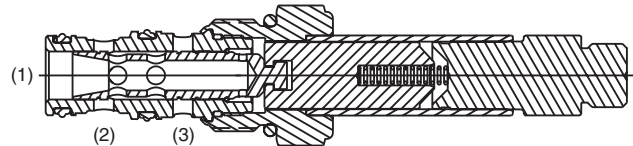
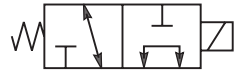

OPERATION - In the de-energized mode, the spool is positioned by spring force. When energized, the coil force directly shifts the spool against the spring, thus changing the flow through the valve. Each spool type can be used as a normally open, normally closed, or selector valve. To explain this we will review the DSL103A which is pictured here. When the valve is de-energized, ports 1 and 2 are open to one another. When energized, ports 1 and 3 are connected.

Thus, if we use port 3 as our pressure port, we have a

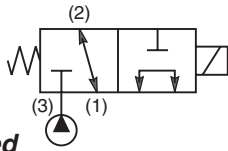

normally closed valve. The pressure port (3) is blocked, while the actuator port (1) is drained to tank (2).

If we use port 2 as our pressure port, we have a

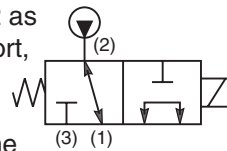

normally open valve. The pressure port (2) is connected to the actuator port (1), and the tank port (3) is blocked.

If we use port 1 as our pressure port, we have a

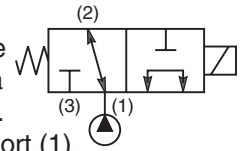

selector valve. The pressure port (1) is either connected to port (2) or port (3). Thus, it is "selecting" which port will get the system pressure and flow.

Note that in all three examples, we were using the same valve. The flow forces acting on the spool change depending on which port is pressurized. Thus, if you will be shifting the three way valve under full flow and pressure, it is important to review the shift limit characteristics for the flow paths you have chosen to be sure the coil has enough force to shift the spool. Various spools are available in this catalog to maximize the flow and pressure capacities for the desired flow function.

**Two Position,
Four Way Spool Valve**

Four way spool solenoid valves provide directional control of flow. Each four way valve has a special internal spool which connects some combination of the four valve ports together. When actuated, the spool connects a different combination of valve ports. These valves are often used for the raise / lower function of a double acting cylinder, or as a forward / reverse function of bi-directional motors.

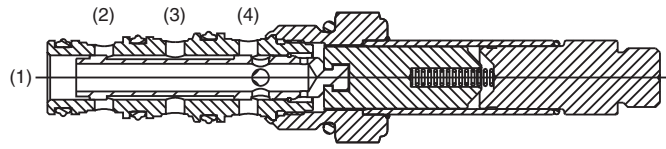
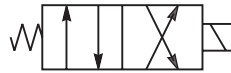

OPERATION - In the de-energized mode, the spool is positioned by spring force. When energized, the coil force directly shifts the spool against the spring, thus changing the flow through the valve. Each spool type is customized to provide the flow combination desired. The flow forces acting on the spool change depending on which port is pressurized. Thus, if you will be shifting the four way valve under full flow and pressure, it is important to review the shift limit characteristics for the flow paths you have chosen to ensure the coil has enough force to shift the spool. Various spools are shown in this catalog to maximize the flow and pressure capacities for the desired flow function.

**Three Position,
Four Way Spool Valve**

Three position, four way spool solenoid valves provide directional control of flow. Each four way valve has a special internal spool which connects some combination of the four ports together. When one coil is actuated, the spool connects a different combination of valve ports. When the other coil is actuated a third combination of valve ports are connected. These valves are often used for the raise / lower function of a double acting cylinder, or as a forward / reverse function of bi-directional motors. The center position can be used to stop the actuator in mid-stroke, or dump the pump flow.

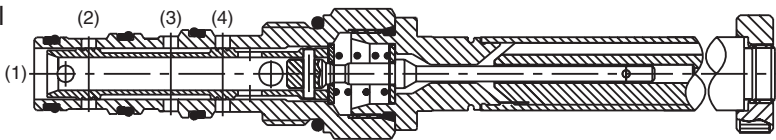

OPERATION - In the de-energized mode, the spool is positioned by spring force. When energized, the coil force directly shifts the against the spring, thus changing the flow through the valve. Each spool type is customized to provide the flow combination desired. The flow forces acting on the spool change depending on which port is pressurized. Thus, if you will be shifting the four way valve under full flow and pressure, it is important to review the shift limit characteristics for the flow paths you chosen to ensure the coil has enough force to shift the spool. Various spools are shown in this catalog to maximize the flow and pressure capacities for the desired flow function.

CV
Check Valves
SH
Shuttle Valves
LM
Load/Motor Controls
FC
Flow Controls
PC
Pressure Controls
LE
Logic Elements
DC
Directional Controls
MV
Manual Valves
SV
Solenoid Valves
PV
Proportional Valves
CE
Coils & Electronics
BC
Bodies & Cavities
TD
Technical Data

Technical Information

- CV** Check Valves
- SH** Shuttle Valves
- LM** Load/Motor Controls
- FC** Flow Controls
- PC** Pressure Controls
- LE** Logic Elements
- DC** Directional Controls
- MV** Manual Valves
- SV** Solenoid Valves
- PV** Proportional Valves
- CE** Coils & Electronics
- BC** Bodies & Cavities
- TD** Technical Data

General Description

2-Way, 2 Position, Normally Closed Spool Valve. For additional information see Technical Tips on pages SV1-SV6.

Features

- High flow capacity
- One piece cartridge housing ensures internal concentricity
- Coil: Waterproof, hermetically sealed, requires no O’Rings; Symmetrical coil can be reversed without affecting performance.

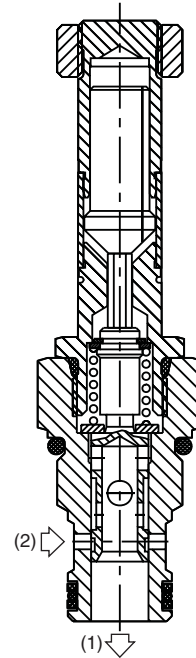
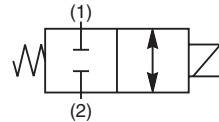

Specifications

Rated Flow (At 70 PSI ΔP)	13 LPM (3.5 GPM)
Maximum Inlet Pressure	350 Bar (5000 PSI)
Leakage at 150 SSU (32 cSt)	82 cc/min @ 210 Bar (3000 PSI)
Minimum Operating Voltage	85% of rated voltage at 20°C (72°F).
Cartridge Material	All parts steel. All operating parts hardened steel.
Operating Temp. Range/Seals	-40°C to +93.3°C (Nitrile) (-40°F to +200°F) -31.7°C to +121.1°C (Fluorocarbon) (-25°F to +250°F)
Fluid Compatibility/ Viscosity	Mineral-based or synthetic with lubricating properties at viscosities of 45 to 2000 SSU (6 to 420 cSt)
Filtration	ISO Code 16/13, SAE Class 4 or better
Approx. Weight	.14 kg (.31 lbs.)
Cavity	C09-2 (See BC Section for more details)

Performance Curves

Pressure Drop vs. Flow (Through cartridge only)

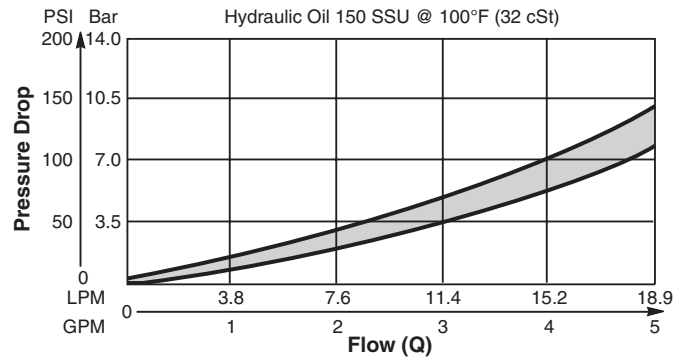

Operating Limits (Measured at 75% of Nominal Current)

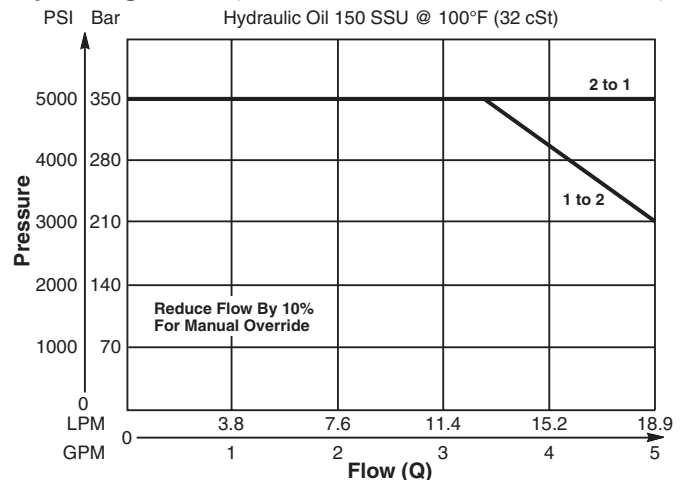

Dimensions Millimeters (Inches)

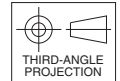
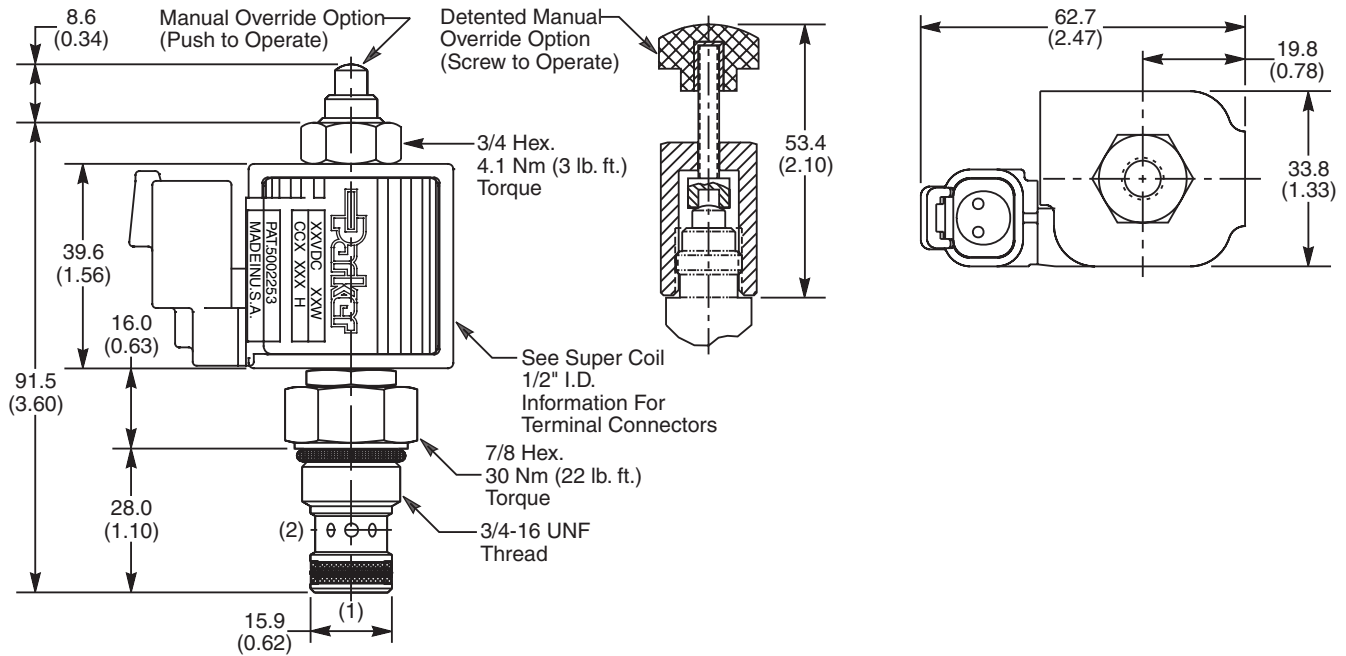

Ordering Information

GS02	22								
09 Size Solenoid Valve	Style Normally Closed	Override Option	Screen	Seals	Coil Type	Coil Voltage	Coil Termination	Body Material	Port Size

Code	Style
22	High Pressure ('SP' Coil)

Code	Seals / Kit No.
N	Nitrile / Buna-N (Std.) (SK30076N-1)
V	Fluorocarbon / (SK30076V-1)

Code	Coil Termination
Omit	Without Coil
C	Conduit With Leads
D	DIN Plug Face
A	Amp Jr. Timer*
S	Dual Spade*
L	Dual Lead Wire*
LS	Sealed Lead Wire*
H	Molded Deutsch*

Code	Body Material
Omit	Steel
A	Aluminum

Code	Override Options
0	None
1	Manual Override
2	Detented Part No. 900690

Code	Coil Type
Omit	Without Coil
SP	Super Coil - 19 Watts

Code	Port Size	Body Part No.
Omit		Cartridge Only
6T	SAE-6	(B09-2-*6T)
6B	3/8" BSPG	(B09-2-6B)†

Code	Screen
0	None

Code	Coil Voltage
Omit	Without Coil
D012	12 VDC
D024	24 VDC
A120	120 VAC, 60/50 Hz
A240	240 VAC, 60/50 Hz*

*22 Watts

See Super Coil 1/2" I.D.
*DC Only

* Add "A" for aluminum, omit for steel.
† Steel body only.

Technical Information

- CV** Check Valves
- SH** Shuttle Valves
- LM** Load/Motor Controls
- FC** Flow Controls
- PC** Pressure Controls
- LE** Logic Elements
- DC** Directional Controls
- MV** Manual Valves
- SV** Solenoid Valves
- PV** Proportional Valves
- CE** Coils & Electronics
- BC** Bodies & Cavities
- TD** Technical Data

General Description

2-Way, 2 Position, Normally Open Spool Valve.
For additional information see Technical Tips on pages SV1-SV6.

Features

- High flow capacity
- One piece cartridge housing ensures internal concentricity
- Coil: Waterproof, hermetically sealed, requires no O’Rings; Symmetrical coil can be reversed without affecting performance.

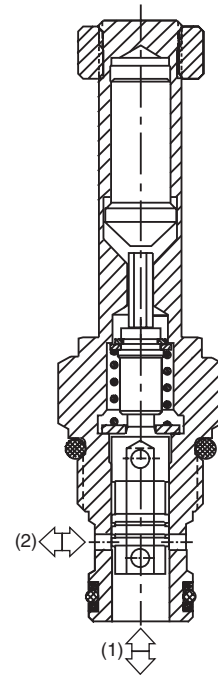
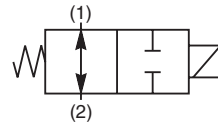

Specifications

Rated Flow (At 70 PSI ΔP)	15 LPM (4 GPM)
Maximum Inlet Pressure	350 Bar (5000 PSI)
Leakage at 150 SSU (32 cSt)	82 cc/min @ 210 Bar (3000 PSI)
Minimum Operating Voltage	85% of rated voltage at 20°C (72°F).
Cartridge Material	All parts steel. All operating parts hardened steel.
Operating Temp. Range/Seals	-40°C to +93.3°C (Nitrile) (-40°F to +200°F) -31.7°C to +121.1°C (Fluorocarbon) (-25°F to +250°F)
Fluid Compatibility/ Viscosity	Mineral-based or synthetic with lubricating properties at viscosities of 45 to 2000 SSU (6 to 420 cSt)
Filtration	ISO Code 16/13, SAE Class 4 or better
Approx. Weight	.14 kg (.31 lbs.)
Cavity	C09-2 (See BC Section for more details)

Performance Curves

Pressure Drop vs. Flow (Through cartridge only)

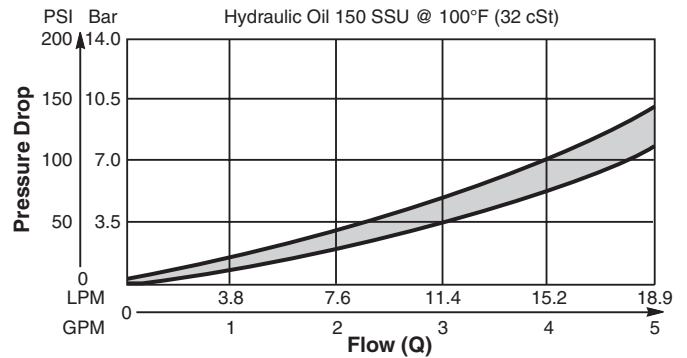

Operating Limits (Measured at 75% of Nominal Current)

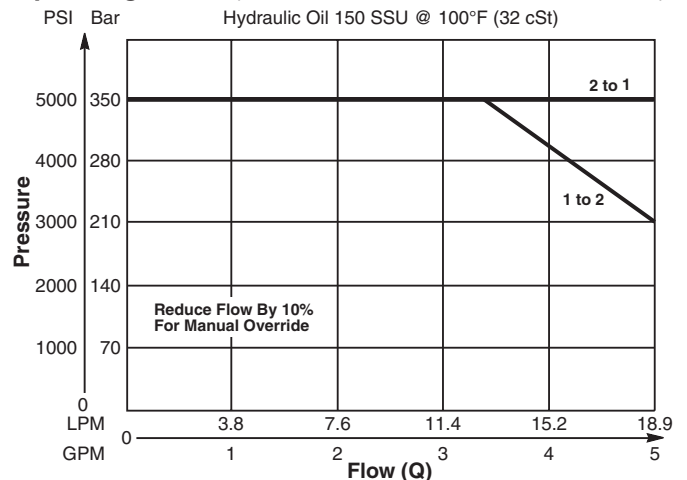

Technical Information

Dimensions Millimeters (Inches)

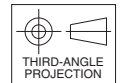
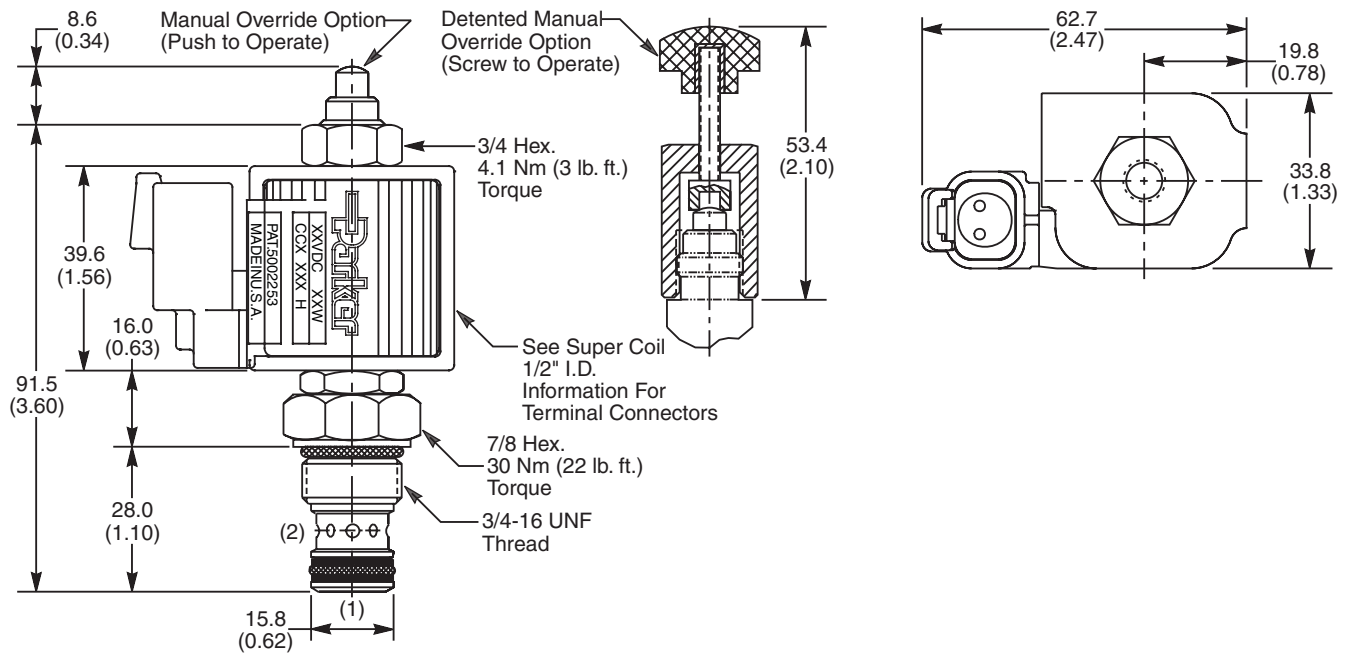

Ordering Information

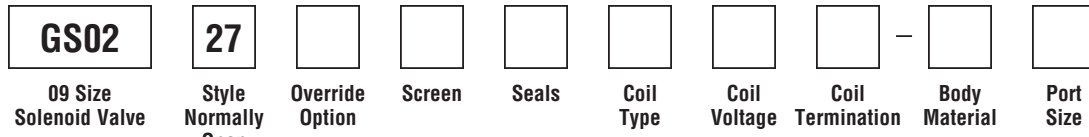

Code	Style
27	High Pressure ('SP' Coil)

Code	Seals / Kit No.
N	Nitrile / Buna-N (Std.) (SK30076N-1)
V	Fluorocarbon / (SK30076V-1)

Code	Coil Termination
Omit	Without Coil
C	Conduit With Leads
D	DIN Plug Face
A	Amp Jr. Timer*
S	Dual Spade*
L	Dual Lead Wire*
LS	Sealed Lead Wire*
H	Molded Deutsch*

Code	Body Material
Omit	Steel
A	Aluminum

Code	Override Options
0	None
1	Manual Override
2	Detented Part No. 900690

Code	Coil Type
Omit	Without Coil
SP	Super Coil - 19 Watts

Code	Port Size	Body Part No.
Omit	Cartridge Only	
6T	SAE-6	(B09-2-*6T)
6B	3/8" BSPG	(B09-2-6B)†

Code	Screen
0	None

Code	Coil Voltage
Omit	Without Coil
D012	12 VDC
D024	24 VDC
A120	120 VAC, 60/50 Hz
A240	240 VAC, 60/50 Hz*

*22 Watts

See Super Coil 1/2" I.D.
*DC Only

* Add "A" for aluminum, omit for steel.
† Steel body only.



- CV Check Valves
- SH Shuttle Valves
- LM Load/Motor Controls
- FC Flow Controls
- PC Pressure Controls
- LE Logic Elements
- DC Directional Controls
- MV Manual Valves
- SV Solenoid Valves
- PV Proportional Valves
- CE Coils & Electronics
- BC Bodies & Cavities
- TD Technical Data

Technical Information

- CV** Check Valves
- SH** Shuttle Valves
- LM** Load/Motor Controls
- FC** Flow Controls
- PC** Pressure Controls
- LE** Logic Elements
- DC** Directional Controls
- MV** Manual Valves
- SV** Solenoid Valves
- PV** Proportional Valves
- CE** Coils & Electronics
- BC** Bodies & Cavities
- TD** Technical Data

General Description

4-Way, 2 Position, Reversing Spool Valve. For additional information see Technical Tips on pages SV1-SV6.

Features

- Designed to operate double and single acting cylinders, pilot circuits and bi-directional motors, etc.
- High flow capacity with reduced space requirements
- High pressure capacity to 350 Bar (5000 PSI)
- One piece cartridge housing ensures internal concentricity
- Coil: Waterproof, hermetically sealed, requires no O'Rings; Symmetrical coil can be reversed without affecting performance.
- Manual override available

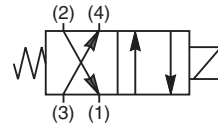
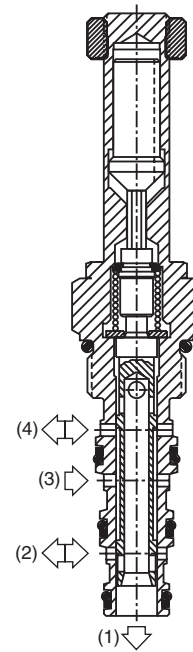

Specifications

Rated Flow (At 70 PSI ΔP)	19 LPM (5 GPM)
Maximum Inlet Pressure	350 Bar (5000 PSI)
Leakage at 150 SSU (32 cSt)	
Minimum Operating Voltage	85% of rated voltage at 20°C (72°F).
Cartridge Material	All parts steel. All operating parts hardened steel.
Operating Temp. Range/Seals	-40°C to +93.3°C (Nitrile) (-40°F to +200°F) -31.7°C to +121.1°C (Fluorocarbon) (-25°F to +250°F)
Fluid Compatibility/ Viscosity	Mineral-based or synthetic with lubricating properties at viscosities of 45 to 2000 SSU (6 to 420 cSt)
Filtration	ISO Code 16/13, SAE Class 4 or better
Approx. Weight	.30 kg (.66 lbs.)
Cavity	C08-4 (See BC Section for more details)

Performance Curves

Pressure Drop vs. Flow (Through cartridge only)

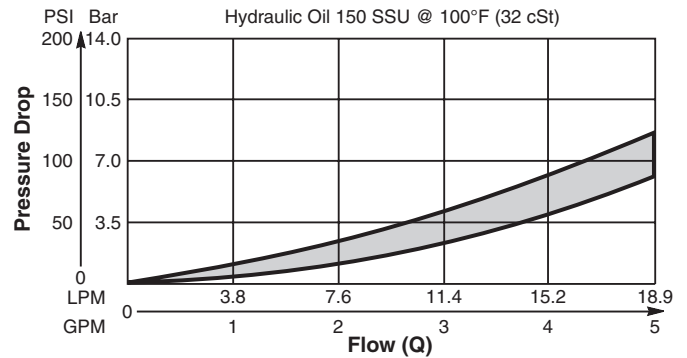

Operating Limits (Measured at 75% of Nominal Current)

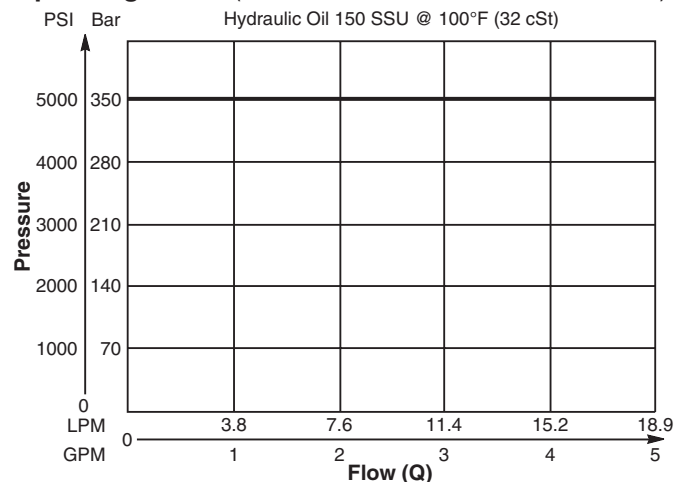

Technical Information

Dimensions Millimeters (Inches)

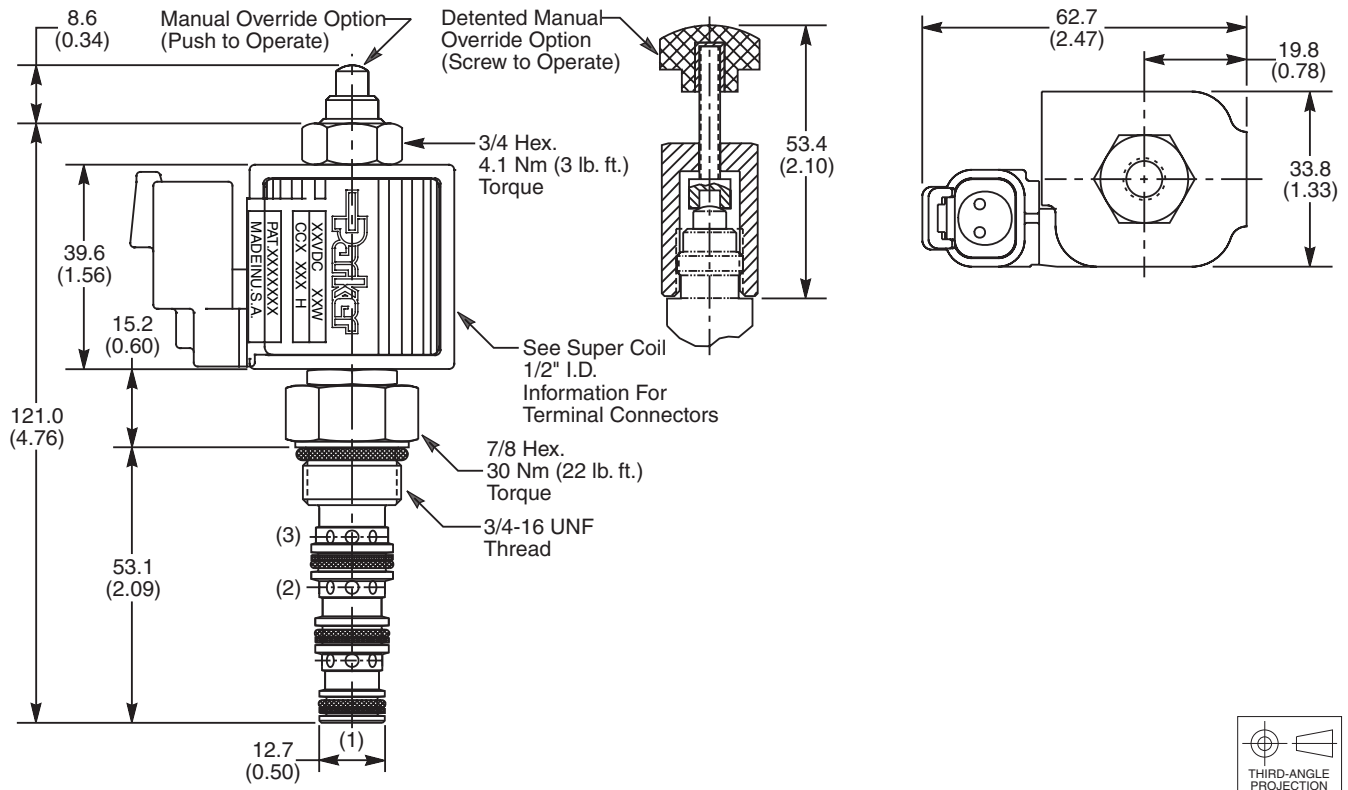

Ordering Information

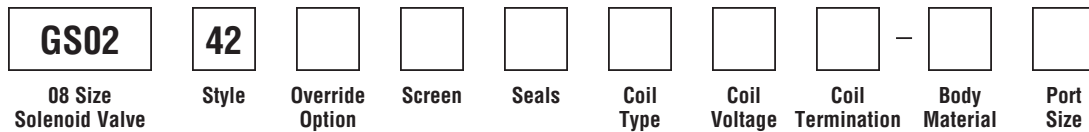

Code	Style
42	High Pressure ('SP' Coil)

Code	Seals / Kit No.
N	Nitrile / Buna-N (Std.) (SK30078N-1)
V	Fluorocarbon / (SK30078V-1)

Code	Coil Termination
Omit	Without Coil
C	Conduit With Leads
D	DIN Plug Face
A	Amp Jr. Timer*
S	Dual Spade*
L	Dual Lead Wire*
LS	Sealed Lead Wire*
H	Molded Deutsch*

Code	Body Material
Omit	Steel
A	Aluminum

Code	Override Options
0	None
1	Manual Override
2	Detented Part No. 900690

Code	Coil Type
Omit	Without Coil
SP	Super Coil - 19 Watts

Code	Port Size	Body Part No.
Omit	Cartridge Only	
6T	SAE-6	(B08-4-*6T)
6B	3/8" BSPG	(B08-4-*6B)

* Add "A" for aluminum, omit for steel.

Code	Screen
0	Not Available

Code	Coil Voltage
Omit	Without Coil
D012	12 VDC
D024	24 VDC
A120	120 VAC, 60/50 Hz
A240	240 VAC, 60/50 Hz*

*22 Watts

See Super Coil 1/2" I.D.
*DC Only

- CV Check Valves
- SH Shuttle Valves
- LM Load/Motor Controls
- FC Flow Controls
- PC Pressure Controls
- LE Logic Elements
- DC Directional Controls
- MV Manual Valves
- SV Solenoid Valves
- PV Proportional Valves
- CE Coils & Electronics
- BC Bodies & Cavities
- TD Technical Data

Technical Information

- CV** Check Valves
- SH** Shuttle Valves
- LM** Load/Motor Controls
- FC** Flow Controls
- PC** Pressure Controls
- LE** Logic Elements
- DC** Directional Controls
- MV** Manual Valves
- SV** Solenoid Valves
- PV** Proportional Valves
- CE** Coils & Electronics
- BC** Bodies & Cavities
- TD** Technical Data

General Description

2-Way Poppet Valves. For additional information see Technical Tips on pages SV1-SV6.



Features

- Replaceable, one piece encapsulated, coils with minimal amperage draw
- Variety of coil terminations and voltages
- Variety of manual override options available
- Fast response available, (CH and CHR) rated at 15 LPM (4.0 GPM)
- Polyurethane "D"-Ring eliminates need for backup rings
- Spherical poppet for low leakage
- Nylon inserted jam-nut provides secure holding in high vibration applications
- All external parts zinc plated

Specifications

Rated Flow (At 70 PSI ΔP)	30 LPM (8 GPM)	
Maximum Inlet Pressure	250 Bar (3600 PSI)	
Leakage at 150 SSU (32 cSt)	5 drops/min. (.33 cc/min.)	
Minimum Operating Voltage	85% of rated voltage at 20°C (72°F).	
Response Time	Energized	De-Energized
C, CR	50 ms	50 ms
CH, CHR	30 ms	50 ms
N, NR	50 ms	40 ms
Cartridge Material	All parts steel. All operating parts hardened steel.	
Operating Temp. Range/Seals	-45°C to +93.3°C ("D"-Ring) (-50°F to +200°F) -31.7°C to +121.1°C (Fluorocarbon) (-25°F to +250°F)	
Fluid Compatibility/Viscosity	Mineral-based or synthetic with lubricating properties at viscosities of 45 to 2000 SSU (6 to 420 cSt)	
Filtration	ISO Code 16/13, SAE Class 4 or better	
Approx. Weight	.11 kg (.25 lbs.)	
Cavity	C08-2 (See BC Section for more details)	
Form Tool	Rougher	None
	Finisher	NFT08-2F

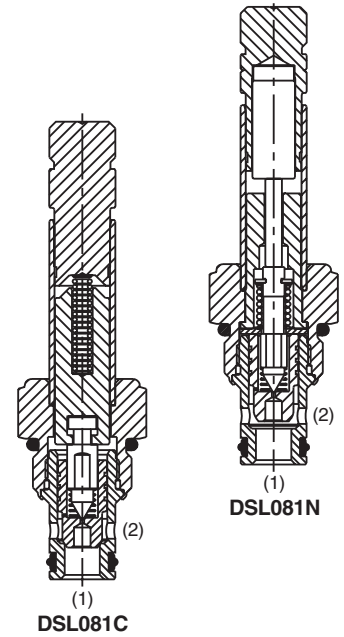
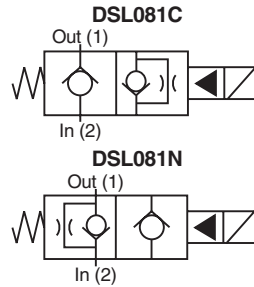

Performance Curves

Pressure Drop vs. Flow (Through cartridge only)

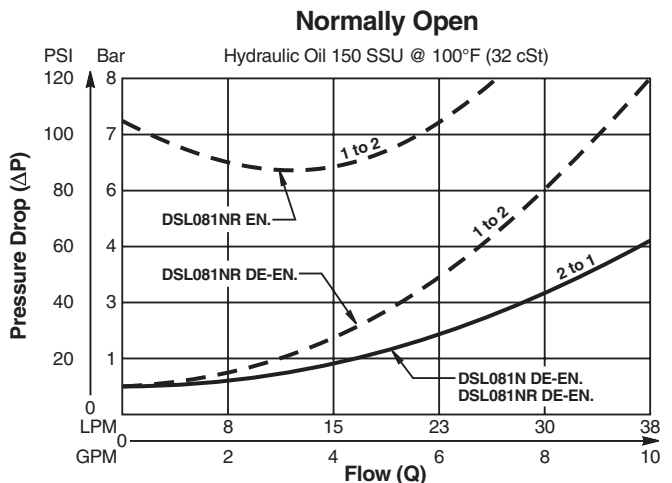
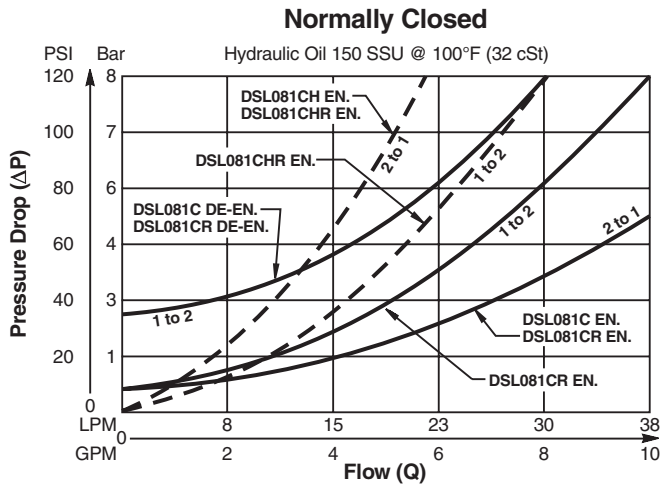

Dimensions Millimeters (Inches)

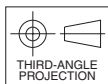
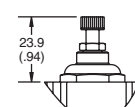
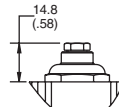
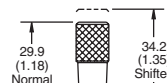
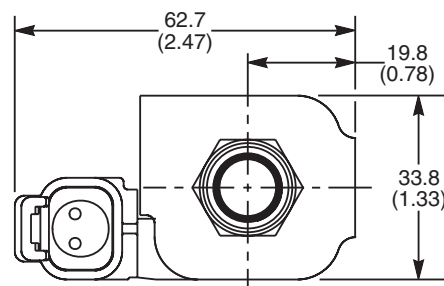
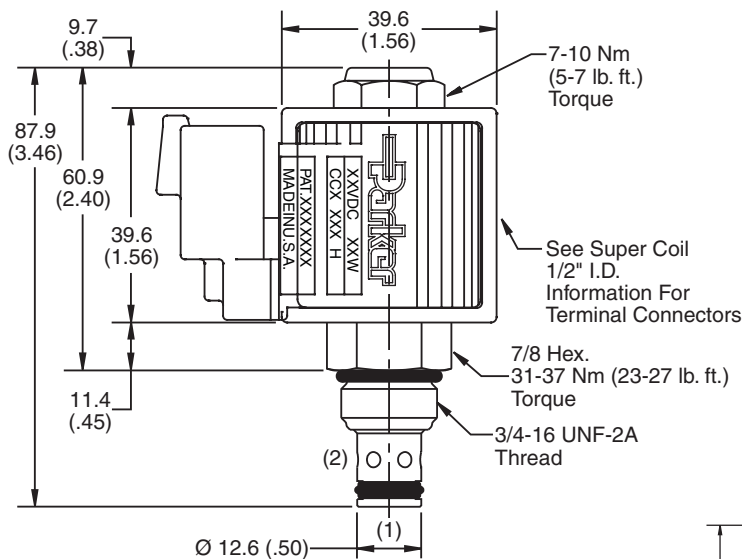

Ordering Information

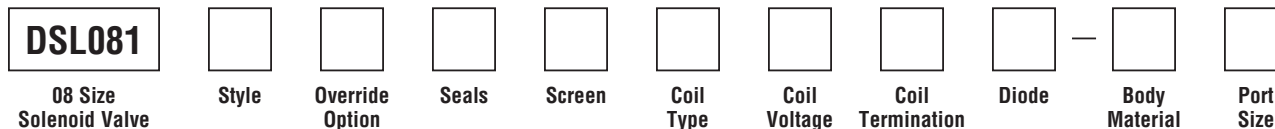

Code / Style	Symbol
C Normally Closed Metered reverse flow	
CH Normally Closed Metered reverse flow (Fast response)	
CHR Normally Closed Full reverse flow (Fast response)	
CR Normally Closed Free reverse flow	
N Normally Open Metered reverse flow	
NR Normally Open Free reverse flow	

Code	Override Options
Omit	None
E	Push Type with Extended Rod (N.O. Only)
M	Push Type with Flush Rod (N.O. Only)
P	Pull & Release (N.C. Only)
T	Push & Twist (N.C. & N.O.)

Code	Seals / Kit No.
Omit	"D"-Ring / (SK08-2)
N	Nitrile / (SK08-2N)
V	Fluorocarbon / (SK08-2V)

Code	Screen
Omit	None
S	Screen

Code	Coil Type
Omit	Without Coil
SP*	Super Coil - 19 Watts

**Recommended*

Code	Coil Voltage
Omit	Without Coil
D012	12 VDC
D024	24 VDC
A120	120/110 VAC, 60/50 Hz
A240	240/220 VAC, 60/50 Hz

SP* Coil	Coil Termination
Omit	Without Coil
C	Conduit With Leads
D	DIN Plug Face
A	Amp Jr. Timert†
S	Dual Spade†
L	Dual Lead Wire†
LS	Sealed Lead Wire†
H	Molded Deutsch†

**Recommended †DC Only*

Code	Diode
Omit	None
R	Diode

Code	Body Material
Omit	Steel
A	Aluminum

Code	Port Size	Body Part No.
Omit	Cartridge Only	
4P	1/4" NPTF	(B08-2-*4P)
6P	3/8" NPTF	(B08-2-*6P)
4T	SAE-4	(B08-2-*4T)
6T	SAE-6	(B08-2-*6T)
6B	3/8" BSPG	(B08-2-*6B)

** Add "A" for aluminum, omit for steel.*

- CV** Check Valves
- SH** Shuttle Valves
- LM** Load/Motor Controls
- FC** Flow Controls
- PC** Pressure Controls
- LE** Logic Elements
- DC** Directional Controls
- MV** Manual Valves
- SV** Solenoid Valves
- PV** Proportional Valves
- CE** Coils & Electronics
- BC** Bodies & Cavities
- TD** Technical Data

Technical Information

- CV** Check Valves
- SH** Shuttle Valves
- LM** Load/Motor Controls
- FC** Flow Controls
- PC** Pressure Controls
- LE** Logic Elements
- DC** Directional Controls
- MV** Manual Valves
- SV** Solenoid Valves
- PV** Proportional Valves
- CE** Coils & Electronics
- BC** Bodies & Cavities
- TD** Technical Data

General Description

2-Way Poppet Valves. For additional information see Technical Tips on pages SV1-SV6.



Features

- Replaceable, one piece encapsulated, coils with minimal amperage draw
- Variety of coil terminations and voltages
- Variety of manual override options available
- Fast response available, (CH and CHR) rated at 15 LPM (4.0 GPM)
- Polyurethane "D"-Ring eliminates need for backup rings
- Spherical poppet for low leakage
- Nylon inserted jam-nut provides secure holding in high vibration applications
- All external parts zinc plated

Specifications

Rated Flow (At 70 PSI ΔP)	30 LPM (8 GPM)	
Maximum Inlet Pressure	350 Bar (5000 PSI)	
Leakage at 150 SSU (32 cSt)	5 drops/min. (.33 cc/min.)	
Minimum Operating Voltage	85% of rated voltage at 20°C (72°F).	
Response Time	Energized	De-Energized
C, CR	50 ms	50 ms
CH, CHR	30 ms	50 ms
N, NR	50 ms	40 ms
Cartridge Material	All parts steel. All operating parts hardened steel.	
Operating Temp. Range/Seals	-45°C to +93.3°C ("D"-Ring) (-50°F to +200°F) -31.7°C to +121.1°C (Fluorocarbon) (-25°F to +250°F)	
Fluid Compatibility/Viscosity	Mineral-based or synthetic with lubricating properties at viscosities of 45 to 2000 SSU (6 to 420 cSt)	
Filtration	ISO Code 16/13, SAE Class 4 or better	
Approx. Weight	.11 kg (.25 lbs.)	
Cavity	C08-2 (See BC Section for more details)	
Form Tool	Rougher Finisher	None NFT08-2F

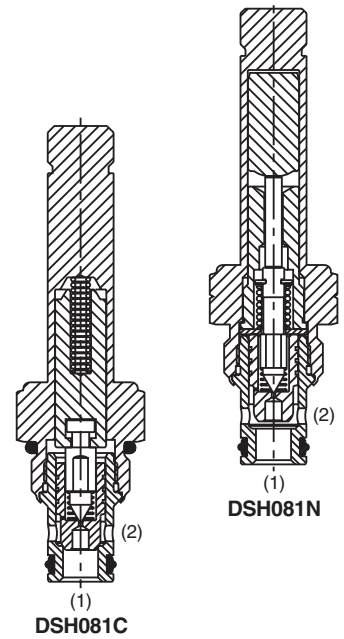
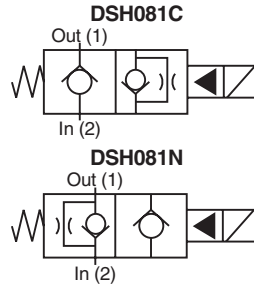

Performance Curves

Pressure Drop vs. Flow (Through cartridge only)

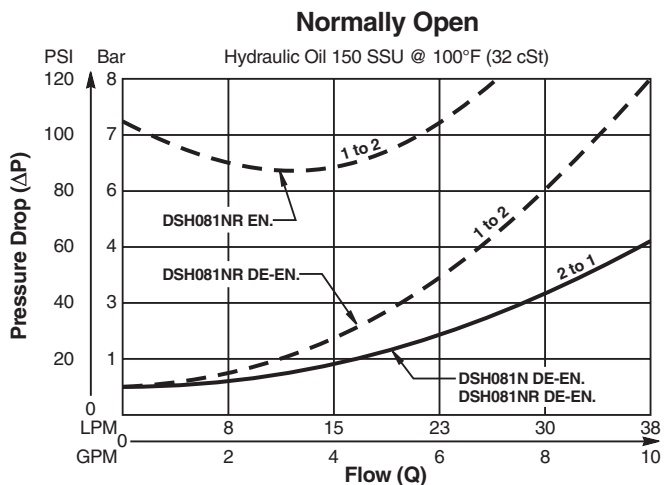
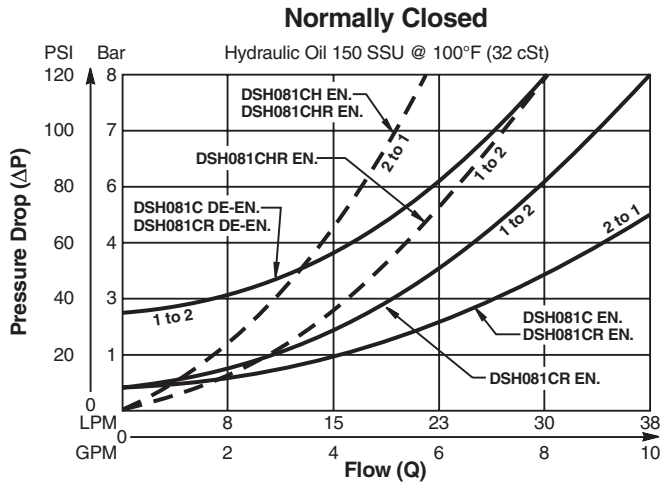

Dimensions Millimeters (Inches)

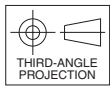
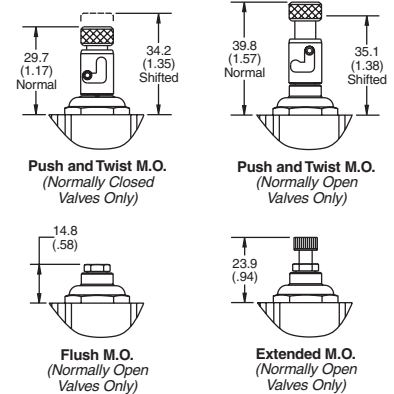
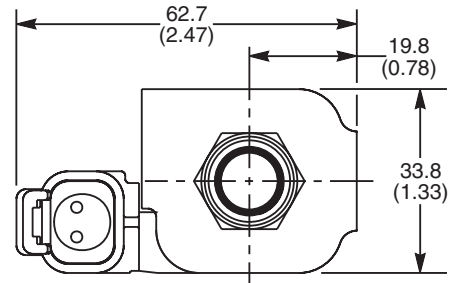
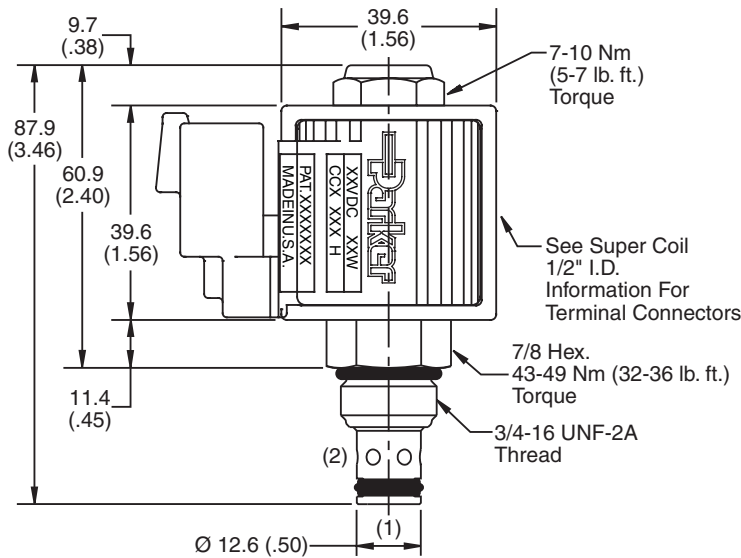

Ordering Information

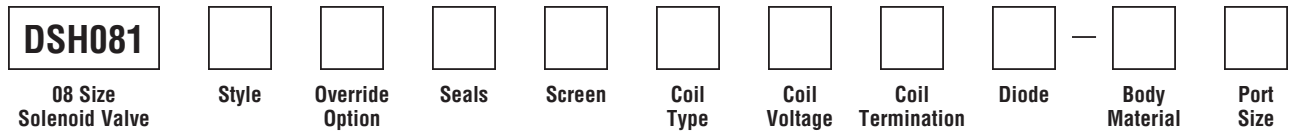

Code / Style	Diagram
C Normally Closed Metered reverse flow	
CH Normally Closed Metered reverse flow (Fast response)	
CHR Normally Closed Free reverse flow (Fast response)	
CR Normally Closed Free reverse flow	
N Normally Open Metered reverse flow	
NR Normally Open Free reverse flow	

Code	Override Options
Omit	None
E	Push Type with Extended Rod (N.O. Only)
M	Push Type with Flush Rod (N.O. Only)
T	Push & Twist (N.C.* & N.O.)

**Requires Super Coil*

Code	Seals / Kit No.
Omit	"D"-Ring / (SK08-2)
N	Nitrile / (SK08-2N)
V	Fluorocarbon / (SK08-2V)

Code	Screen
Omit	None
S	Screen

Code	Coil Type
Omit	Without Coil
SP*	Super Coil - 19 Watts

**Recommended*

Code	Coil Voltage
Omit	Without Coil
D012	12 VDC
D024	24 VDC
A120	120/110 VAC, 60/50 Hz
A240	240/220 VAC, 60/50 Hz

SP* Coil	Coil Termination
Omit	Without Coil
C	Conduit With Leads
D	DIN Plug Face
A	Amp Jr. Timert†
S	Dual Spade†
L	Dual Lead Wire†
LS	Sealed Lead Wire†
H	Molded Deutsch†

**Recommended †DC Only*

Code	Diode
Omit	None
R	Diode

Code	Body Material
Omit	Steel
A	Aluminum

Code	Port Size	Body Part No.
Omit	Cartridge Only	
4P	1/4" NPTF	(B08-2-*4P)
6P	3/8" NPTF	(B08-2-*6P)
4T	SAE-4	(B08-2-*4T)
6T	SAE-6	(B08-2-*6T)
6B	3/8" BSPG	(B08-2-*6B)

** Add "A" for aluminum, omit for steel.*

Technical Information

General Description

2-Way Poppet Valves. For additional information see Technical Tips on pages SV1-SV6.



Features

- Low hysteresis
- Replaceable, one piece encapsulated coils with minimal amperage draw
- Various coil terminations and voltages
- Various manual override options
- Fast response available, (CH and CHR) rated at 11 LPM (3.0 GPM)
- Polyurethane "D"-Ring
- All external parts zinc plated

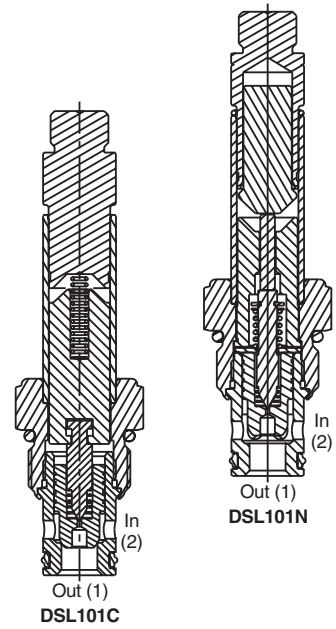
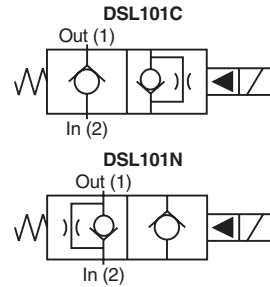

Specifications

Rated Flow (At 70 PSI ΔP)	60 LPM (15 GPM)		
Maximum Inlet Pressure	250 Bar (3600 PSI)		
Leakage at 150 SSU (32 cSt)	5 drops/min. (.33 cc/min.)		
Minimum Operating Voltage	85% of rated voltage at 20°C (72°F).		
Response Time		Energized	De-Energized
	C, CR	80 ms	150 ms
	CH, CHR	50 ms	50 ms
	N, NR	35 ms	175 ms
Cartridge Material	All parts steel. All operating parts hardened steel.		
Operating Temp. Range/Seals	-45°C to +93.3°C ("D"-Ring) (-50°F to +200°F) -31.7°C to +121.1°C (Fluorocarbon) (-25°F to +250°F)		
Fluid Compatibility/Viscosity	Mineral-based or synthetic with lubricating properties at viscosities of 45 to 2000 SSU (6 to 420 cSt)		
Filtration	ISO Code 16/13, SAE Class 4 or better		
Approx. Weight	.20 kg (0.41 lbs.)		
Cavity	C10-2 (See BC Section for more details)		
Form Tool	Rougher Finisher	None	NFT10-2F

Performance Curves

Pressure Drop vs. Flow (Through cartridge only)

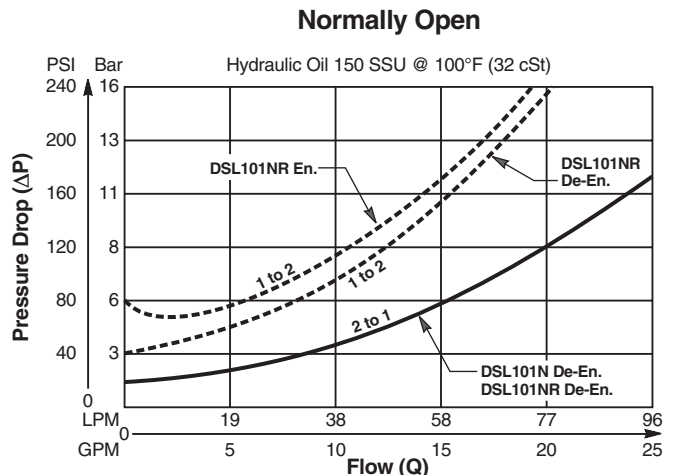
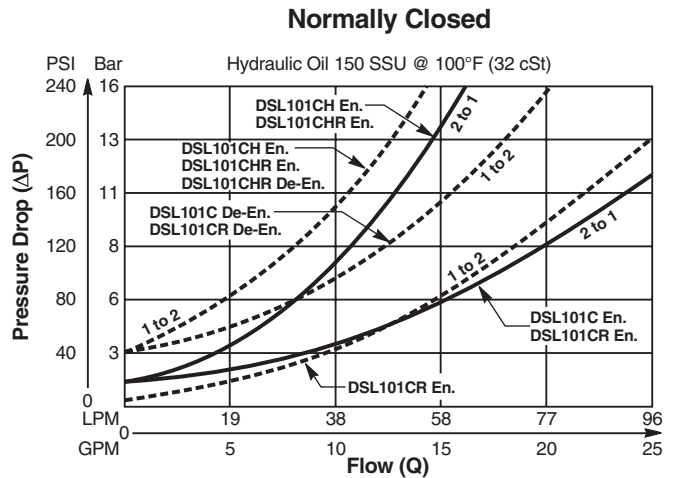

- CV** Check Valves
- SH** Shuttle Valves
- LM** Load/Motor Controls
- FC** Flow Controls
- PC** Pressure Controls
- LE** Logic Elements
- DC** Directional Controls
- MV** Manual Valves
- SV** Solenoid Valves
- PV** Proportional Valves
- CE** Coils & Electronics
- BC** Bodies & Cavities
- TD** Technical Data

Dimensions Millimeters (Inches)

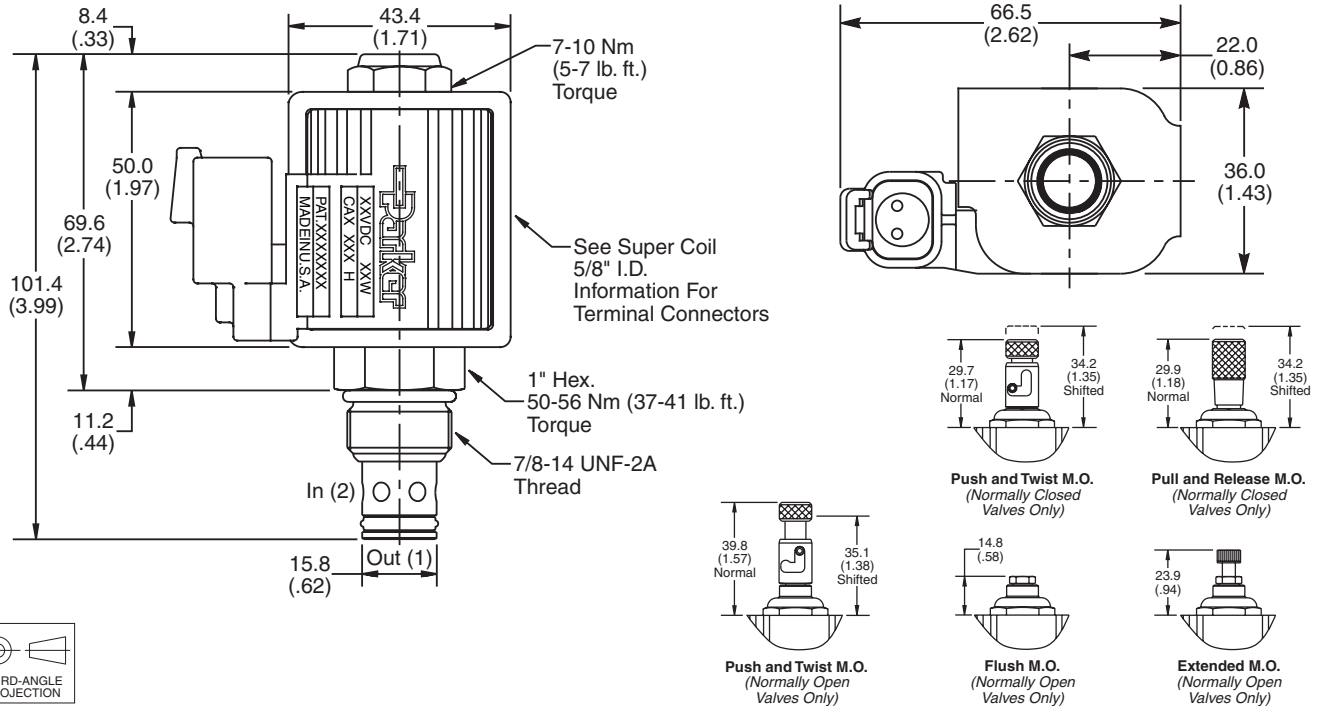

Ordering Information

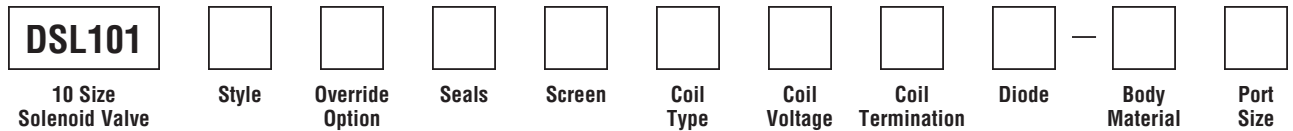

Code / Style	Diagram
C Normally Closed Metered reverse flow	
CH Normally Closed Metered reverse flow (Fast response)	
CHR Normally Closed Free reverse flow (Fast response)	
CR Normally Closed Free reverse flow	
N Normally Open Metered reverse flow	
NR Normally Open Free reverse flow	

Code	Override Options
Omit	None
E	Push Type with Extended Rod (N.O. Only)
M	Push Type with Flush Rod (N.O. Only)
P	Pull & Release (N.C. Only)
T	Push & Twist (N.C. & N.O.)

Code	Seals / Kit. No.
Omit	"D"-Ring / (SK10-2)
N	Nitrile / (SK10-2N)
V	Fluorocarbon / (SK10-2V)

Code	Screen
Omit	None
S	Screen

Code	Coil Type
Omit	Without Coil
SP*	Super Coil - 28 Watts

*Recommended

Code	Coil Voltage
Omit	Without Coil
D012	12 VDC
D024	24 VDC
A120	120/110 VAC, 60/50 Hz
A240	240/220 VAC, 60/50 Hz

SP* Coil	Coil Termination
Omit	Without Coil
C	Conduit With Leads
D	DIN Plug Face
A	Amp Jr. Timert†
S	Dual Spade†
L	Dual Lead Wire†
LS	Sealed Lead Wire†
H	Molded Deutsch†

*Recommended †DC Only

Code	Diode
Omit	None
R	Diode

Code	Body Material
Omit	Steel
A	Aluminum

Code	Port Size	Body Part No.
Omit	Cartridge Only	
4P	1/4" NPTF	(B10-2-*4P)
6P	3/8" NPTF	(B10-2-*6P)
8P	1/2" NPTF	(B10-2-*8P)
6T	SAE-6	(B10-2-*6T)
8T	SAE-8	(B10-2-*8T)
T8T	SAE-8	(B10-2-T8T)†
6B	3/8" BSPG	(B10-2-6B)†

* Add "A" for aluminum. omit for steel. † Steel body only.

Technical Information

- CV** Check Valves
- SH** Shuttle Valves
- LM** Load/Motor Controls
- FC** Flow Controls
- PC** Pressure Controls
- LE** Logic Elements
- DC** Directional Controls
- MV** Manual Valves
- SV** Solenoid Valves
- PV** Proportional Valves
- CE** Coils & Electronics
- BC** Bodies & Cavities
- TD** Technical Data

General Description

2-Way Poppet Valves. For additional information see Technical Tips on pages SV1-SV6.



Features

- Low hysteresis
- Replaceable, one piece encapsulated coils with minimal amperage draw
- Various coil terminations and voltages
- Various manual override options
- Fast response available, (CH and CHR) rated at 30 LPM (8 GPM)
- Polyurethane "D"-Ring eliminates need for backup rings
- Nylon inserted jam-nut provides secure holding in high vibration applications
- All external parts zinc plated

Specifications

Rated Flow (At 70 PSI ΔP)	60 LPM (15 GPM)	
Maximum Inlet Pressure	350 Bar (5000 PSI)	
Leakage at 150 SSU (32 cSt)	5 drops/min. (.33 cc/min.)	
Minimum Operating Voltage	85% of rated voltage at 20°C (72°F).	
Response Time	Energized	De-Energized
C, CR	80 ms	150 ms
CH, CHR	50 ms	50 ms
N, NR	70 ms	35 ms
Cartridge Material	All parts steel. All operating parts hardened steel.	
Operating Temp. Range/Seals	-45°C to +93.3°C ("D"-Ring) (-50°F to +200°F) -31.7°C to +121.1°C (Fluorocarbon) (-25°F to +250°F)	
Fluid Compatibility/Viscosity	Mineral-based or synthetic with lubricating properties at viscosities of 45 to 2000 SSU (6 to 420 cSt)	
Filtration	ISO Code 16/13, SAE Class 4 or better	
Approx. Weight	.20 kg (0.41 lbs.)	
Cavity	C10-2 (See BC Section for more details)	
Form Tool	Rougher Finisher	None NFT10-2F

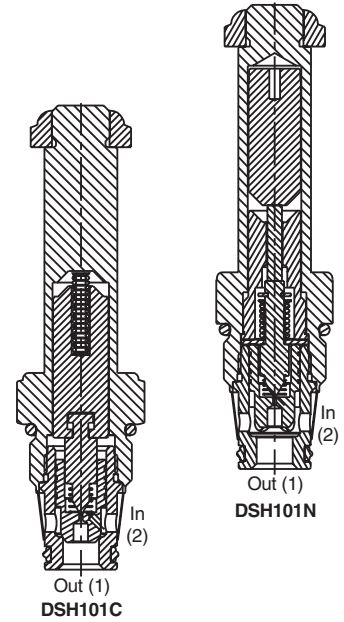
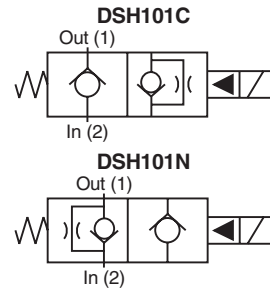

Performance Curves

Pressure Drop vs. Flow (Through cartridge only)

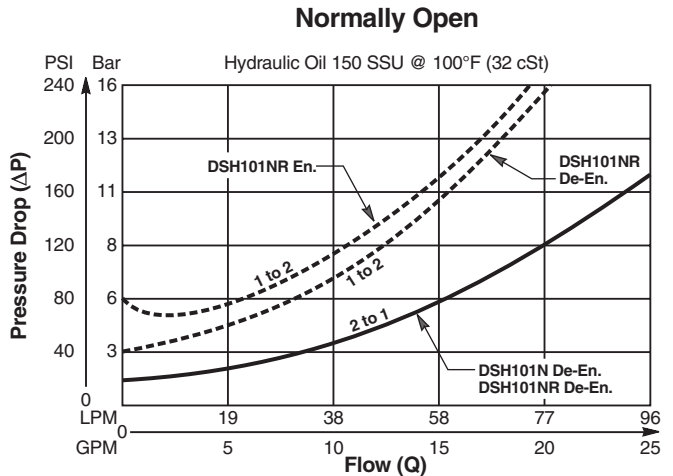
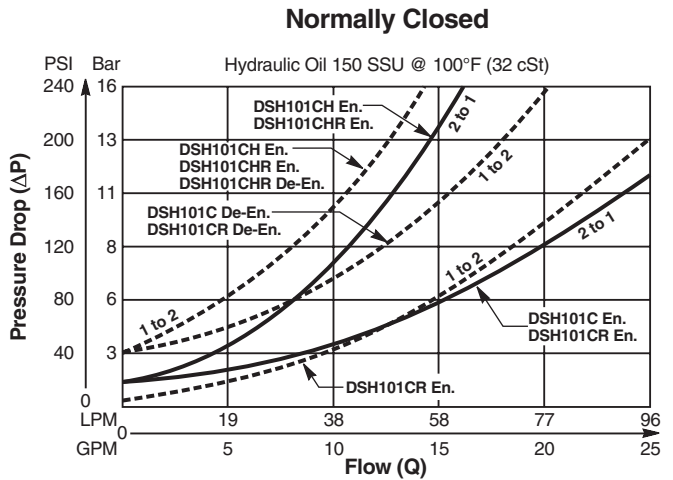

Dimensions Millimeters (Inches)

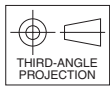
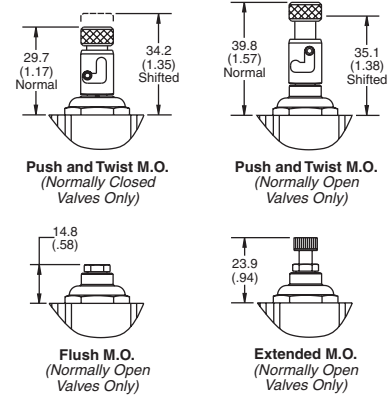
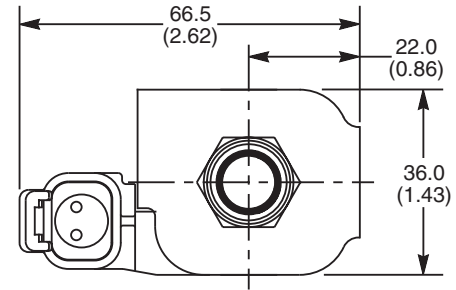
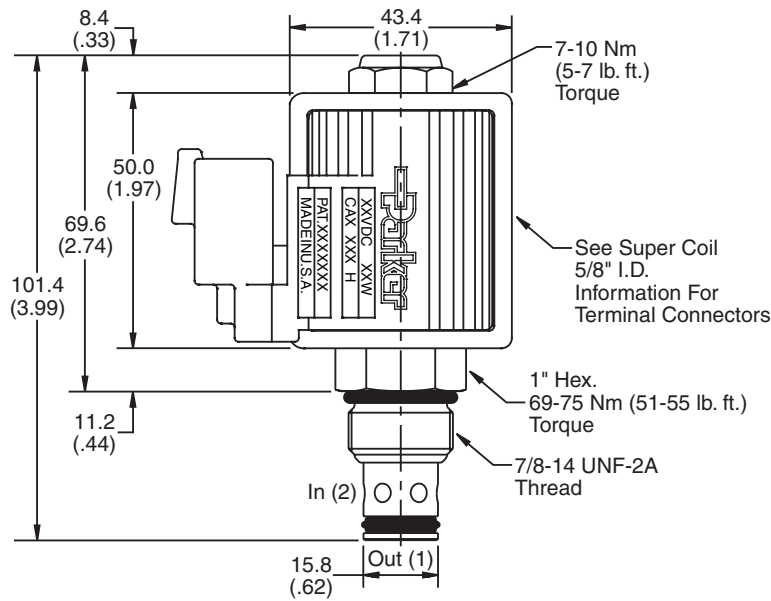

Ordering Information

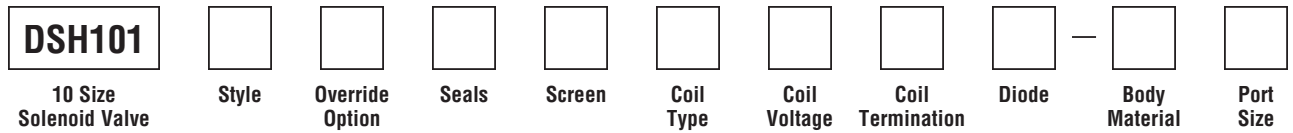

Code / Style	
C Normally Closed Metered reverse flow	
CH Normally Closed Metered reverse flow (Fast response)	
CHR Normally Closed Free reverse flow (Fast response)	
CR Normally Closed Free reverse flow	
N Normally Open Metered reverse flow	
NR Normally Open Free reverse flow	

Code	Override Options
Omit	None
E	Push Type with Extended Rod (N.O. Only)
M	Push Type with Flush Rod (N.O. Only)
T	Push & Twist (N.C. & N.O.)

Code	Seals / Kit No.
Omit	"D"-Ring / (SK10-2)
N	Nitrile / (SK10-2N)
V	Fluorocarbon / (SK10-2V)

Code	Screen
Omit	None
S	Screen

Code	Coil Type
Omit	Without Coil
SP*	Super Coil - 28 Watts

*Recommended

Code	Coil Voltage
Omit	Without Coil
D012	12 VDC
D024	24 VDC
A120	120/110 VAC, 60/50 Hz
A240	240/220 VAC, 60/50 Hz

SP* Coil	Coil Termination
Omit	Without Coil
C	Conduit With Leads
D	DIN Plug Face
A	Amp Jr. Timert†
S	Dual Spade†
L	Dual Lead Wire†
LS	Sealed Lead Wire†
H	Molded Deutsch†

*Recommended †DC Only

Code	Diode
Omit	None
R	Diode

Code	Body Material
Omit	Steel
A	Aluminum

Code	Port Size	Body Part No.
Omit	Cartridge Only	
4P	1/4" NPTF	(B10-2-*4P)
6P	3/8" NPTF	(B10-2-*6P)
8P	1/2" NPTF	(B10-2-*8P)
6T	SAE-6	(B10-2-*6T)
8T	SAE-8	(B10-2-*8T)
T8T	SAE-8	(B10-2-T8T)†
6B	3/8" BSPG	(B10-2-6B)†

* Add "A" for aluminum. omit for steel.
† Steel body only.

Technical Information

- CV** Check Valves
- SH** Shuttle Valves
- LM** Load/Motor Controls
- FC** Flow Controls
- PC** Pressure Controls
- LE** Logic Elements
- DC** Directional Controls
- MV** Manual Valves
- SV** Solenoid Valves
- PV** Proportional Valves
- CE** Coils & Electronics
- BC** Bodies & Cavities
- TD** Technical Data

General Description

2-Way Poppet Valves. For additional information see Technical Tips on pages SV1-SV6.

Features

- Low hysteresis
- Replaceable, one piece encapsulated coils with minimal amperage draw
- Various coil terminations and voltages
- Various manual override options
- All external parts zinc plated

Specifications

Rated Flow	90 LPM (24 GPM)		
Maximum Inlet Pressure	350 Bar (5000 PSI)		
Leakage at 150 SSU (32 cSt)	5 drops/min. (.33 cc/min.)		
Minimum Operating Voltage	85% of rated voltage at 20°C (72°F).		
Response Time		Energized	De-Energized
	C, CR	100 ms	150 ms
	CH, CHR	60 ms	60 ms
	N, NR	70 ms	150 ms
Cartridge Material	All parts steel. All operating parts hardened steel.		
Operating Temp. Range/Seals	-40°C to +93.3°C (Nitrile) (-40°F to +200°F) -31.7°C to +121.1°C (Fluorocarbon) (-25°F to +250°F)		
Fluid Compatibility/ Viscosity	Mineral-based or synthetic with lubricating properties at viscosities of 45 to 2000 SSU (6 to 420 cSt)		
Filtration	ISO Code 16/13, SAE Class 4 or better		
Approx. Weight	.29 kg (.65 lbs.)		
Cavity	C12-2 (See BC Section for more details)		
Form Tool	Rougher Finisher	None	NFT12-2F

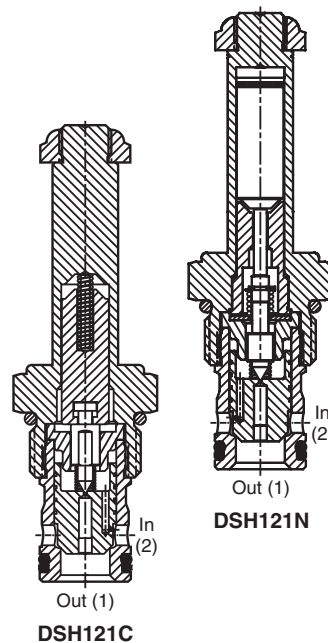
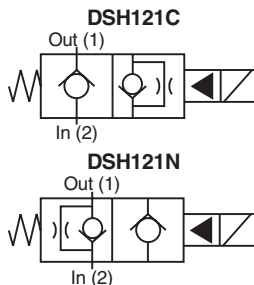

Performance Curves

Pressure Drop vs. Flow (Through cartridge only)

Normally Closed

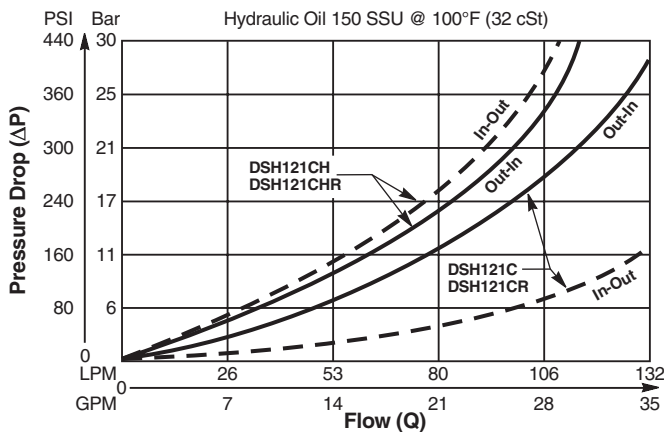

Normally Open

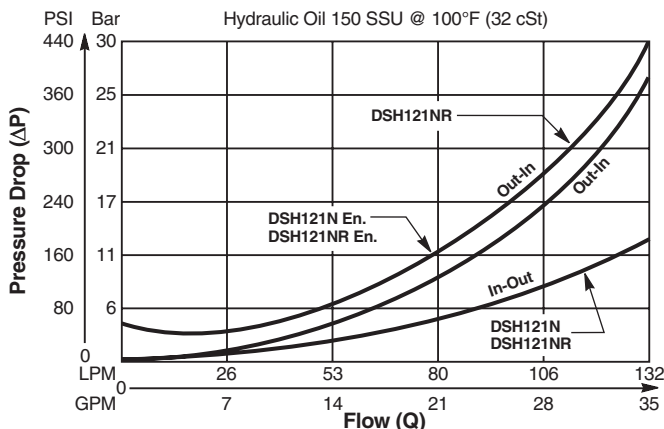

Dimensions Millimeters (Inches)

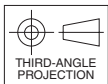
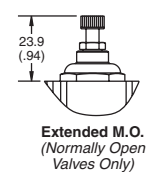
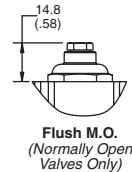
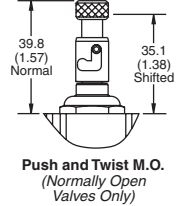
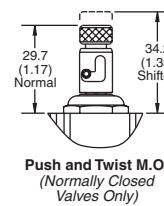
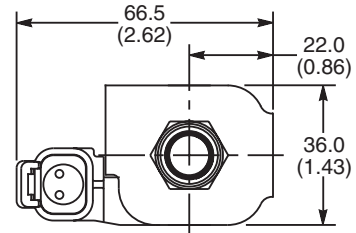
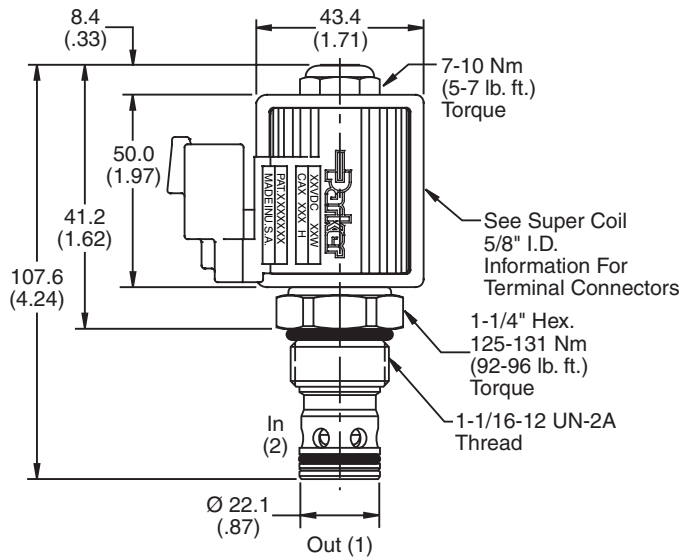

Ordering Information

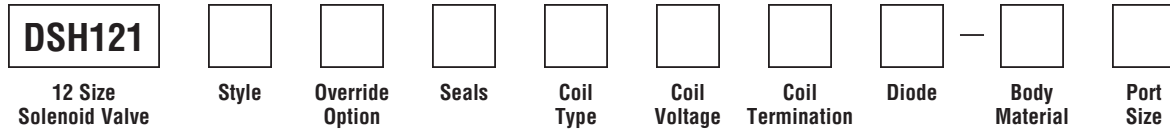

Code / Style	Diagram
C Normally Closed Metered reverse flow	
CH Normally Closed Metered reverse flow (Fast response)	
CHR Normally Closed Full reverse flow (Fast response)	
CR Normally Closed Free reverse flow	
N Normally Open Metered reverse flow	
NR Normally Open Free reverse flow	

Code	Override Options
Omit	None
E	Push Type with Extended Rod (N.O. Only)
M	Push Type with Flush Rod (N.O. Only)
T	Push & Twist (N.C. & N.O.)

Code	Seals / Kit No.
Omit	Nitrile / (SK12-2)
V	Fluorocarbon / (SK12-2V)

Code	Coil Type
Omit	Without Coil
SP*	Super Coil - 28 Watts

**Recommended*

Code	Coil Voltage
Omit	Without Coil
D012	12 VDC
D024	24 VDC
A120	120/110 VAC, 60/50 Hz
A240	240/220 VAC, 60/50 Hz

SP* Coil	Coil Termination
Omit	Without Coil
C	Conduit With Leads
D	DIN Plug Face
A	Amp Jr. Timert†
S	Dual Spade†
L	Dual Lead Wire†
LS	Sealed Lead Wire†
H	Molded Deutsch†

**Recommended †DC Only*

Code	Diode
Omit	None
R	Diode

Code	Body Material
Omit	Steel
A	Aluminum

Code	Port Size	Body Part No.
Omit		Cartridge Only
12P	3/4" NPTF	(B12-2-*12P)
8T	SAE-8	(B12-2-*8T)
12T	SAE-12	(B12-2-*12T)

** Add "A" for aluminum, omit for steel.*

- CV**
Check Valves
- SH**
Shuttle Valves
- LM**
Load/Motor Controls
- FC**
Flow Controls
- PC**
Pressure Controls
- LE**
Logic Elements
- DC**
Directional Controls
- MV**
Manual Valves
- SV**
Solenoid Valves
- PV**
Proportional Valves
- CE**
Coils & Electronics
- BC**
Bodies & Cavities
- TD**
Technical Data

Technical Information

- CV** Check Valves
- SH** Shuttle Valves
- LM** Load/Motor Controls
- FC** Flow Controls
- PC** Pressure Controls
- LE** Logic Elements
- DC** Directional Controls
- MV** Manual Valves
- SV** Solenoid Valves
- PV** Proportional Valves
- CE** Coils & Electronics
- BC** Bodies & Cavities
- TD** Technical Data

General Description

2-Way Poppet Valves. For additional information see Technical Tips on pages SV1-SV6.

Features

- Low hysteresis
- Replaceable, one piece encapsulated coils with minimal amperage draw
- Various coil terminations and voltages
- Various manual override options
- Fast response available, (CH) rated at 60 LPM (15 GPM)
- All external parts zinc plated

Specifications

Rated Flow	150 LPM (40 GPM)		
Maximum Inlet Pressure	210 Bar (3000 PSI)		
Leakage at 150 SSU (32 cSt)	20 drops/min. (1.33 cc/min.)		
Minimum Operating Voltage	85% of rated voltage at 20°C (72°F).		
Response Time		Energized	De-Energized
	C, CR	50 ms	130 ms
	CH	40 ms	60 ms
	N, NR	45 ms	75 ms
Cartridge Material	All parts steel. All operating parts hardened steel.		
Operating Temp. Range/Seals	-40°C to +93.3°C (Nitrile) (-40°F to +200°F) -31.7°C to +121.1°C (Fluorocarbon) (-25°F to +250°F)		
Fluid Compatibility/Viscosity	Mineral-based or synthetic with lubricating properties at viscosities of 45 to 2000 SSU (6 to 420 cSt)		
Filtration	ISO Code 16/13, SAE Class 4 or better		
Approx. Weight	.34 kg (.75 lbs.)		
Cavity	C16-2 (See BC Section for more details)		
Form Tool	Rougher	None	
	Finisher	NFT16-2F	

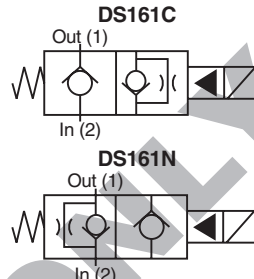
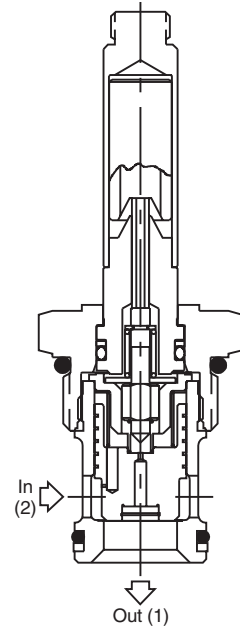
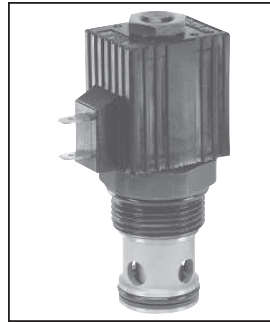

Performance Curves

Pressure Drop vs. Flow (Through cartridge only)

Normally Closed

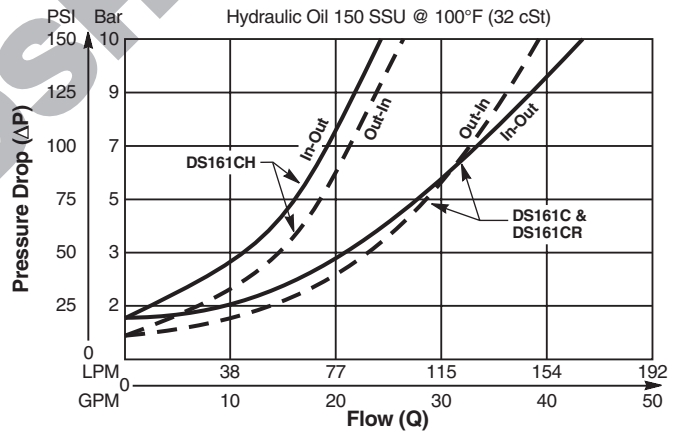

Normally Open

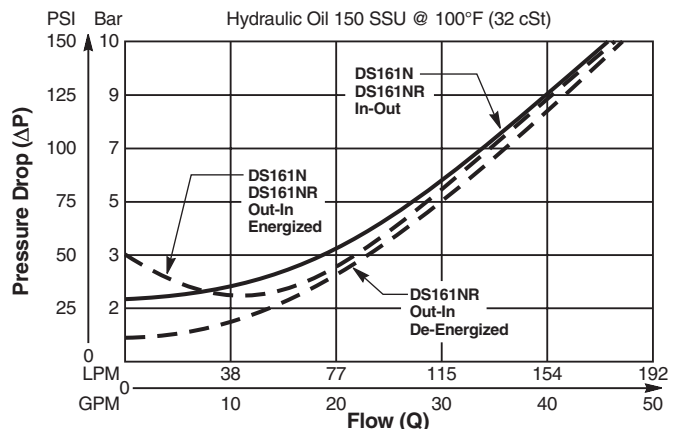

Dimensions Millimeters (Inches)

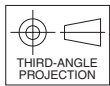
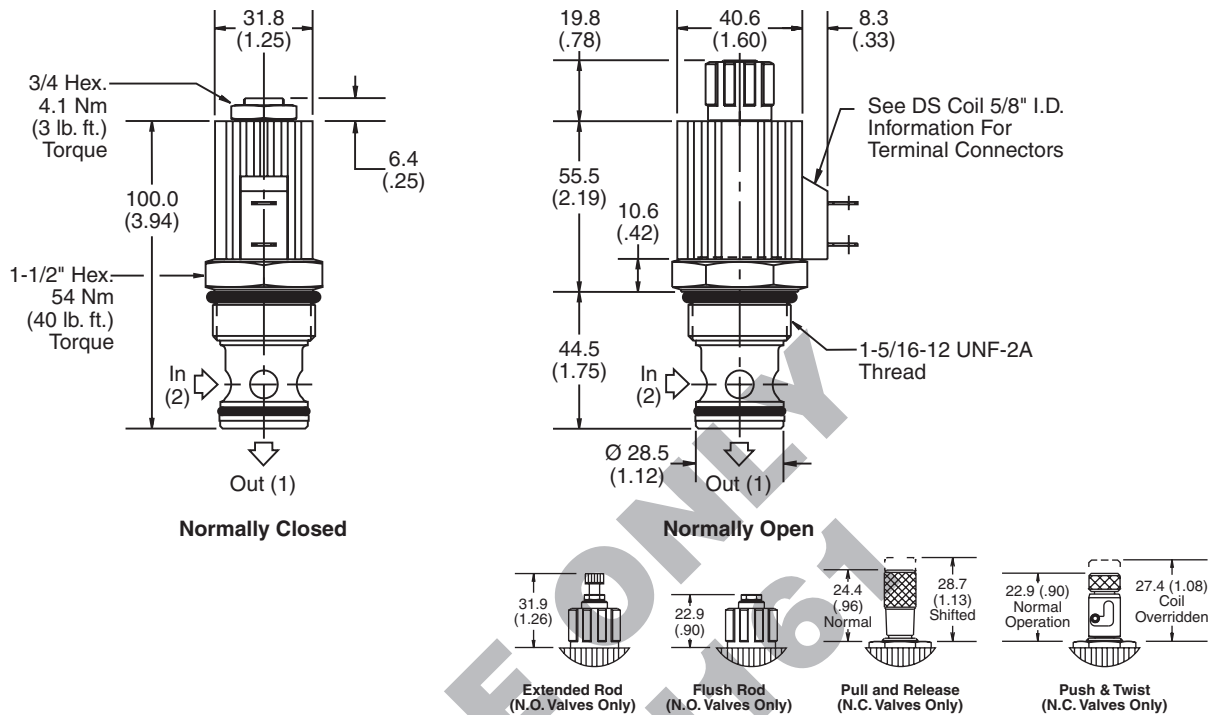

Ordering Information

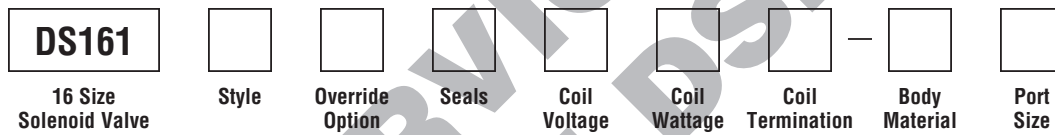

Code / Style	Diagram
C Normally Closed Metered reverse flow	
CH Normally Closed Metered reverse flow (Fast response)	
CR Normally Closed Free reverse flow	
N Normally Open Metered reverse flow	
NR Normally Open Free reverse flow	

Code	Override Options
Omit	None
E	Push Type with Extended Rod (N.O. Only)
M	Push Type with Flush Rod (N.O. Only)
P	Pull & Release (N.C. Only)
T	Push & Twist (N.C. Only)

Code	Seals / Kit. No.
Omit	Nitrile / (SK16-2)
V	Fluorocarbon / (SK16-2V)

Code	Coil Voltage
Omit	Without Coil
D012	12 VDC
D024	24 VDC
A120	120/110 VAC, 60/50 Hz
A240	240/220 VAC, 60/50 Hz

Code	Wattage
Omit	Without Coil
L	17 Watts
H	30 Watts

Code	Coil Termination
Omit	Without Coil
C	Conduit (AC Only)
D	DIN Plug Face
P	Dual Spade (DC Only)
S	Dual Screw (DC Only)
W	Dual Lead (DC Only)

See DS coil 5/8" I.D.

Code	Body Material
Omit	Steel
A	Aluminum

Code	Port Size	Body Part No.
Omit	Cartridge Only	
12T	SAE-12	(B16-2-*12T)
16T	SAE-16	(B16-2-*16T)
12B	3/4" BSPG	(B16-2-*12B)
16B	1" BSPG	(B16-2-16B)†

* Add "A" for aluminum, omit for steel.
 † Steel body only.

Technical Information

- CV** Check Valves
- SH** Shuttle Valves
- LM** Load/Motor Controls
- FC** Flow Controls
- PC** Pressure Controls
- LE** Logic Elements
- DC** Directional Controls
- MV** Manual Valves
- SV** Solenoid Valves
- PV** Proportional Valves
- CE** Coils & Electronics
- BC** Bodies & Cavities
- TD** Technical Data

General Description

2-Way Poppet Valves. For additional information see Technical Tips on pages SV1-SV6.



Features

- Replaceable, one piece encapsulated coils with minimal amperage draw
- Various coil terminations and voltages
- Various manual override options
- All external parts zinc plated
- New 350 Bar (5000 PSI) rating

NOTE:

This valve will be available January 1, 2011.

Specifications

Rated Flow	150 LPM (40 GPM)		
Maximum Inlet Pressure	350 Bar (5000 PSI)		
Leakage at 150 SSU (32 cSt)	5 drops/min. (.33 cc/min.)		
Minimum Operating Voltage	85% of rated voltage at 20°C (72°F).		
Response Time		Energized	De-Energized
	C, CR	50 ms	130 ms
	CH	40 ms	60 ms
	N, NR	45 ms	75 ms
Cartridge Material	All parts steel. All operating parts hardened steel.		
Operating Temp. Range/Seals	-40°C to +93.3°C (Nitrile) (-40°F to +200°F) -31.7°C to +121.1°C (Fluorocarbon) (-25°F to +250°F)		
Fluid Compatibility/ Viscosity	Mineral-based or synthetic with lubricating properties at viscosities of 45 to 2000 SSU (6 to 420 cSt)		
Filtration	ISO Code 16/13, SAE Class 4 or better		
Approx. Weight	.34 kg (.75 lbs.)		
Cavity	C16-2 (See BC Section for more details)		
Form Tool	Rougher	None	
	Finisher	NFT16-2F	

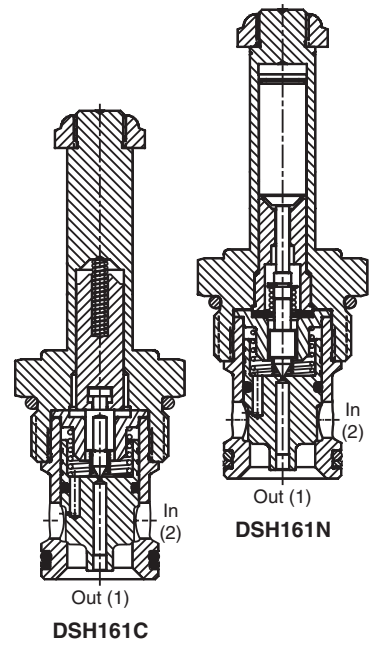
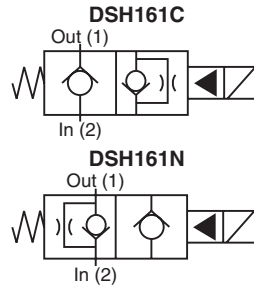

Performance Curves

Pressure Drop vs. Flow (Through cartridge only)

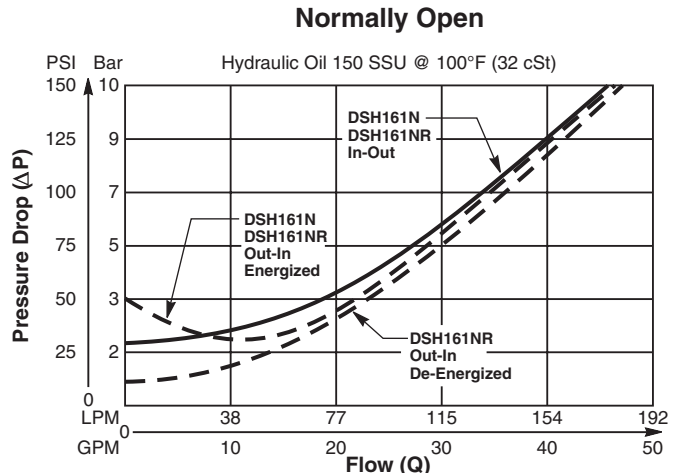
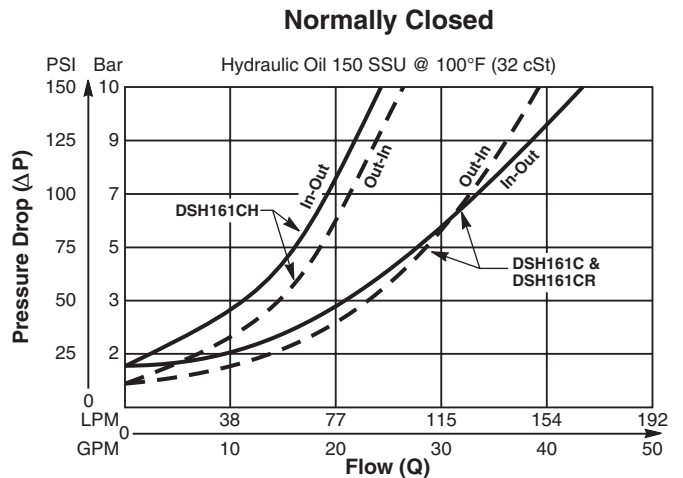

Dimensions Millimeters (Inches)

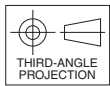
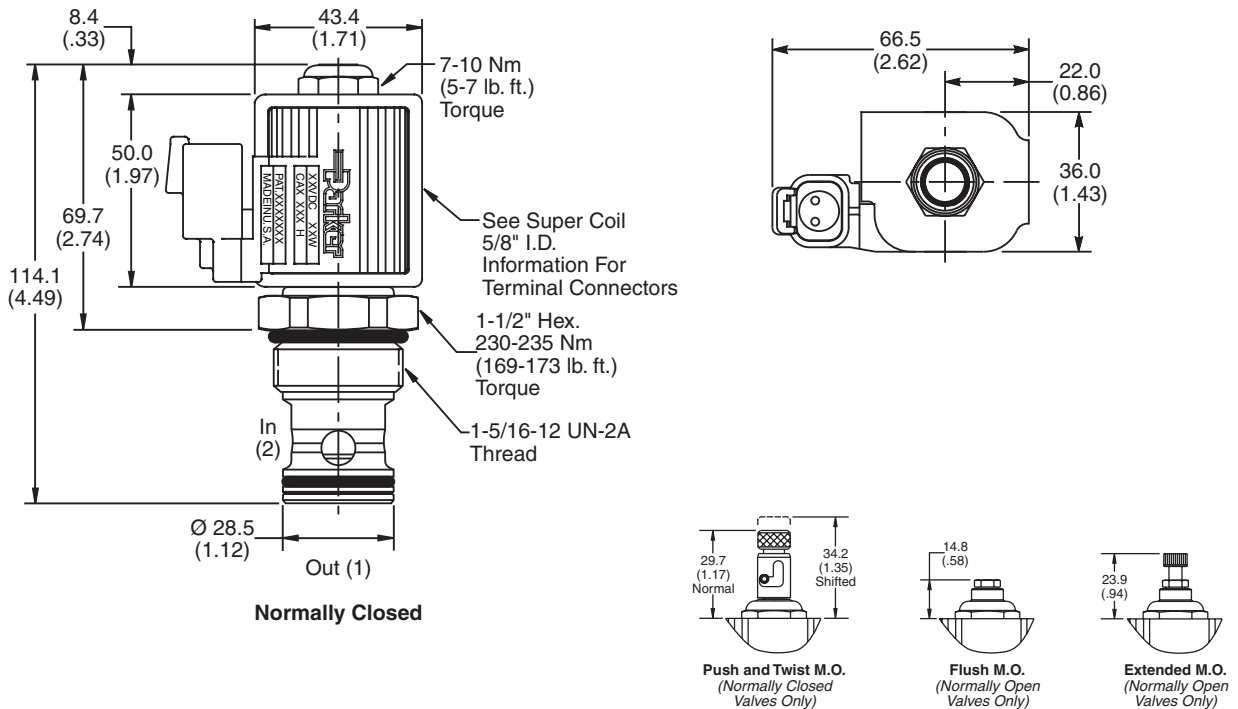

Ordering Information

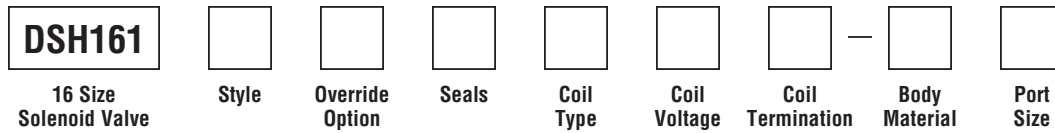

NOTE: This valve will be available January 1, 2011.

Code / Style	Symbol
C Normally Closed Metered reverse flow	
CH Normally Closed Metered reverse flow (Fast response)	
CR Normally Closed Free reverse flow	
N Normally Open Metered reverse flow	
NR Normally Open Free reverse flow	

Code	Override Options
Omit	None
E	Push Type with Extended Rod (N.O. Only)
M	Push Type with Flush Rod (N.O. Only)
T	Push & Twist (N.C. Only)

Code	Seals / Kit. No.
Omit	Nitrile / (SK16-2)
V	Fluorocarbon / (SK16-2V)

Code	Coil Type
Omit	Without Coil
SP*	Super Coil - 28 Watts

**Recommended*

Code	Coil Voltage
Omit	Without Coil
D012	12 VDC
D024	24 VDC
A120	120/110 VAC, 60/50 Hz
A240	240/220 VAC, 60/50 Hz

Code	Body Material
Omit	Steel
A	Aluminum

Code	Port Size	Body Part No.
Omit	Cartridge Only	
12T	SAE-12	(B16-2-*12T)
16T	SAE-16	(B16-2-*16T)
12B	3/4" BSPG	(B16-2-*12B)
16B	1" BSPG	(B16-2-16B)†

** Add "A" for aluminum, omit for steel.
 † Steel body only.*

SP* Coil	Coil Termination
Omit	Without Coil
C	Conduit With Leads
D	DIN Plug Face
A	Amp Jr. Timer†
S	Dual Spade†
L	Dual Lead Wire†
LS	Sealed Lead Wire†
H	Molded Deutsch†

**Recommended †DC Only*

- CV**
Check Valves
- SH**
Shuttle Valves
- LM**
Load/Motor Controls
- FC**
Flow Controls
- PC**
Pressure Controls
- LE**
Logic Elements
- DC**
Directional Controls
- MV**
Manual Valves
- SV**
Solenoid Valves
- PV**
Proportional Valves
- CE**
Coils & Electronics
- BC**
Bodies & Cavities
- TD**
Technical Data

Technical Information

- CV** Check Valves
- SH** Shuttle Valves
- LM** Load/Motor Controls
- FC** Flow Controls
- PC** Pressure Controls
- LE** Logic Elements
- DC** Directional Controls
- MV** Manual Valves
- SV** Solenoid Valves
- PV** Proportional Valves
- CE** Coils & Electronics
- BC** Bodies & Cavities
- TD** Technical Data

General Description

2-Way Poppet Valves. For additional information see Technical Tips on pages SV1-SV6.

Features

- Low hysteresis
- Replaceable, one piece encapsulated coils with minimal amperage draw
- Various coil terminations and voltages
- Various manual override options
- All external parts zinc plated

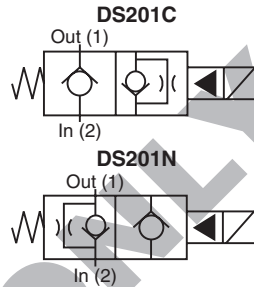
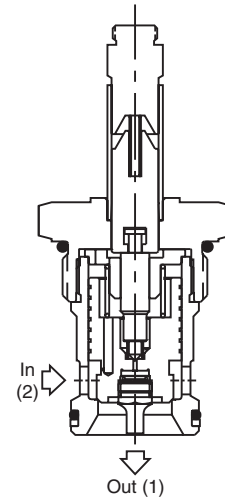
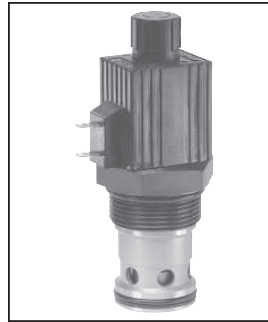

Specifications

Rated Flow (At 70 PSI ΔP)	260 LPM (70 GPM)	
Maximum Inlet Pressure	210 Bar (3000 PSI)	
Leakage at 150 SSU (32 cSt)	20 drops/min. (1.33 cc/min.)	
Minimum Operating Voltage	85% of rated voltage at 20°C (72°F).	
Response Time	Energized	De-Energized
	C, CR N, NR	160 ms 45 ms
		350 ms 300 ms
Cartridge Material	All parts steel. All operating parts hardened steel.	
Operating Temp. Range/Seals	-40°C to +93.3°C (Nitrile) (-40°F to +200°F) -31.7°C to +121.1°C (Fluorocarbon) (-25°F to +250°F)	
Fluid Compatibility/Viscosity	Mineral-based or synthetic with lubricating properties at viscosities of 45 to 2000 SSU (6 to 420 cSt)	
Filtration	ISO Code 16/13, SAE Class 4 or better	
Approx. Weight	.34 kg (.75 lbs.)	
Cavity	C20-2 (See BC Section for more details)	
Form Tool	Rougher Finisher	None NFT20-2F

Performance Curve

Pressure Drop vs. Flow (Through cartridge only)

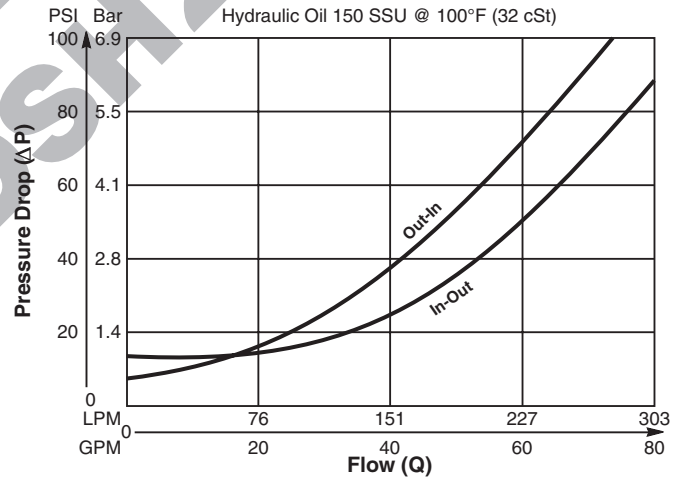

Dimensions Millimeters (Inches)

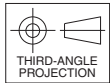
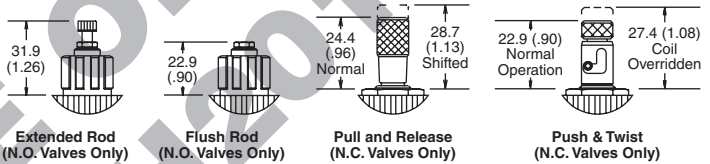
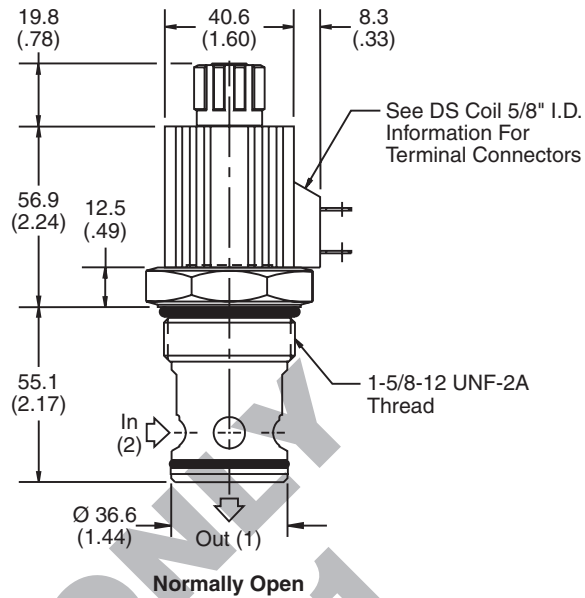
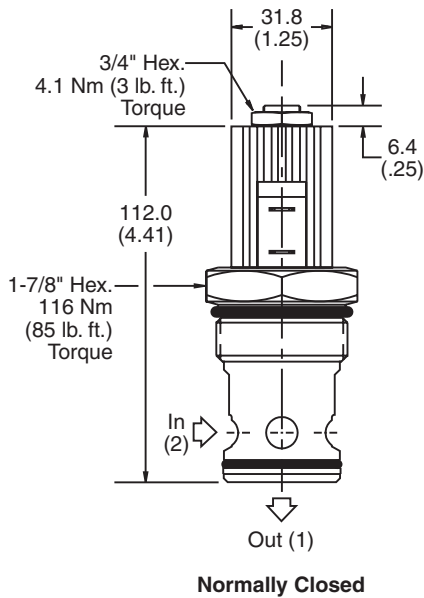

Ordering Information

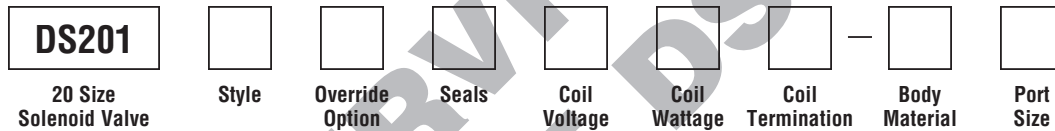

Code / Style	Symbol
C Normally Closed Metered reverse flow	
CR Normally Closed Free reverse flow	
N Normally Open Metered reverse flow	
NR Normally Open Free reverse flow	

Code	Override Options
Omit	None
E	Push Type with Extended Rod (N.O. Only)
M	Push Type with Flush Rod (N.O. Only)
P	Pull & Release (N.C. Only)
T	Push & Twist (N.C. Only)

Code	Wattage
Omit	Without Coil
L	17 Watts
H	30 Watts

Code	Body Material
Omit	Steel

Code	Port Size	Body Part No.
Omit	Cartridge Only	
20T	SAE-20	(B20-2-20T)
20B	1-1/4" BSPG	(B20-2-20B)

Code	Seals / Kit. No.
Omit	Nitrile / (SK20-2)
V	Fluorocarbon / (SK20-2V)

Code	Coil Termination
Omit	Without Coil
C	Conduit (AC Only)
D	DIN Plug Face
P	Dual Spade (DC Only)
S	Dual Screw (DC Only)
W	Dual Lead (DC Only)

See DS coil 5/8" I.D.

Code	Coil Voltage
Omit	Without Coil
D012	12 VDC
D024	24 VDC
A120	120/110 VAC, 60/50 Hz
A240	240/220 VAC, 60/50 Hz

- CV** Check Valves
- SH** Shuttle Valves
- LM** Load/Motor Controls
- FC** Flow Controls
- PC** Pressure Controls
- LE** Logic Elements
- DC** Directional Controls
- MV** Manual Valves
- SV** Solenoid Valves
- PV** Proportional Valves
- CE** Coils & Electronics
- BC** Bodies & Cavities
- TD** Technical Data

Technical Information

- CV** Check Valves
- SH** Shuttle Valves
- LM** Load/Motor Controls
- FC** Flow Controls
- PC** Pressure Controls
- LE** Logic Elements
- DC** Directional Controls
- MV** Manual Valves
- SV** Solenoid Valves
- PV** Proportional Valves
- CE** Coils & Electronics
- BC** Bodies & Cavities
- TD** Technical Data

General Description

2-Way Poppet Valves. For additional information see Technical Tips on pages SV1-SV6.



Features

- Replaceable, one piece encapsulated coils with minimal amperage draw
- Various coil terminations and voltages
- Various manual override options
- All external parts zinc plated
- New 250 Bar (3600 PSI) rating

NOTE:

This valve will be available January 1, 2011.

Specifications

Rated Flow (At 70 PSI ΔP)	260 LPM (70 GPM)		
Maximum Inlet Pressure	250 Bar (3600 PSI)		
Leakage at 150 SSU (32 cSt)	5 drops/min. (.33 cc/min.)		
Minimum Operating Voltage	85% of rated voltage at 20°C (72°F).		
Response Time		Energized	De-Energized
	C, CR	350 ms	160 ms
	N, NR	300 ms	45 ms
Cartridge Material	All parts steel. All operating parts hardened steel.		
Operating Temp. Range/Seals	-40°C to +93.3°C (Nitrile) (-40°F to +200°F) -31.7°C to +121.1°C (Fluorocarbon) (-25°F to +250°F)		
Fluid Compatibility/ Viscosity	Mineral-based or synthetic with lubricating properties at viscosities of 45 to 2000 SSU (6 to 420 cSt)		
Filtration	ISO Code 16/13, SAE Class 4 or better		
Approx. Weight	.34 kg (.75 lbs.)		
Cavity	C20-2 (See BC Section for more details)		
Form Tool	Rougher Finisher	None	NFT20-2F

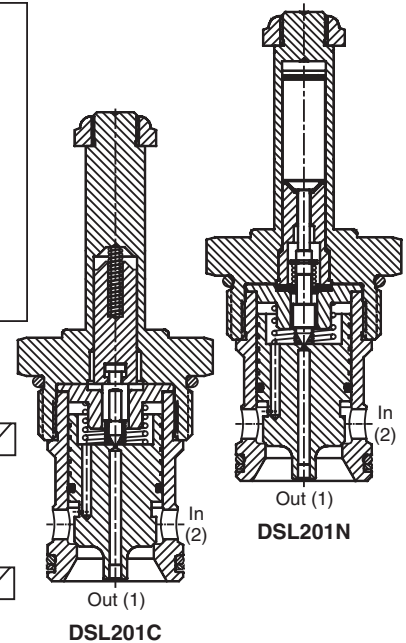
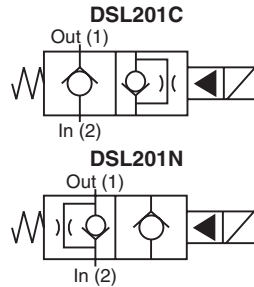

Performance Curve

Pressure Drop vs. Flow (Through cartridge only)

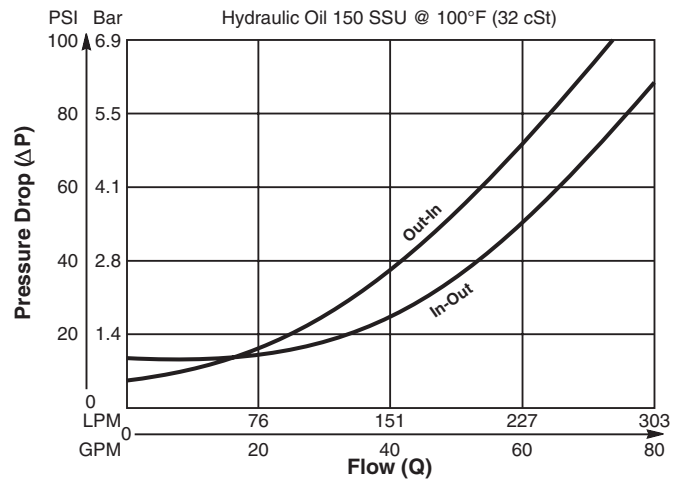

Dimensions Millimeters (Inches)

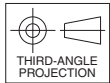
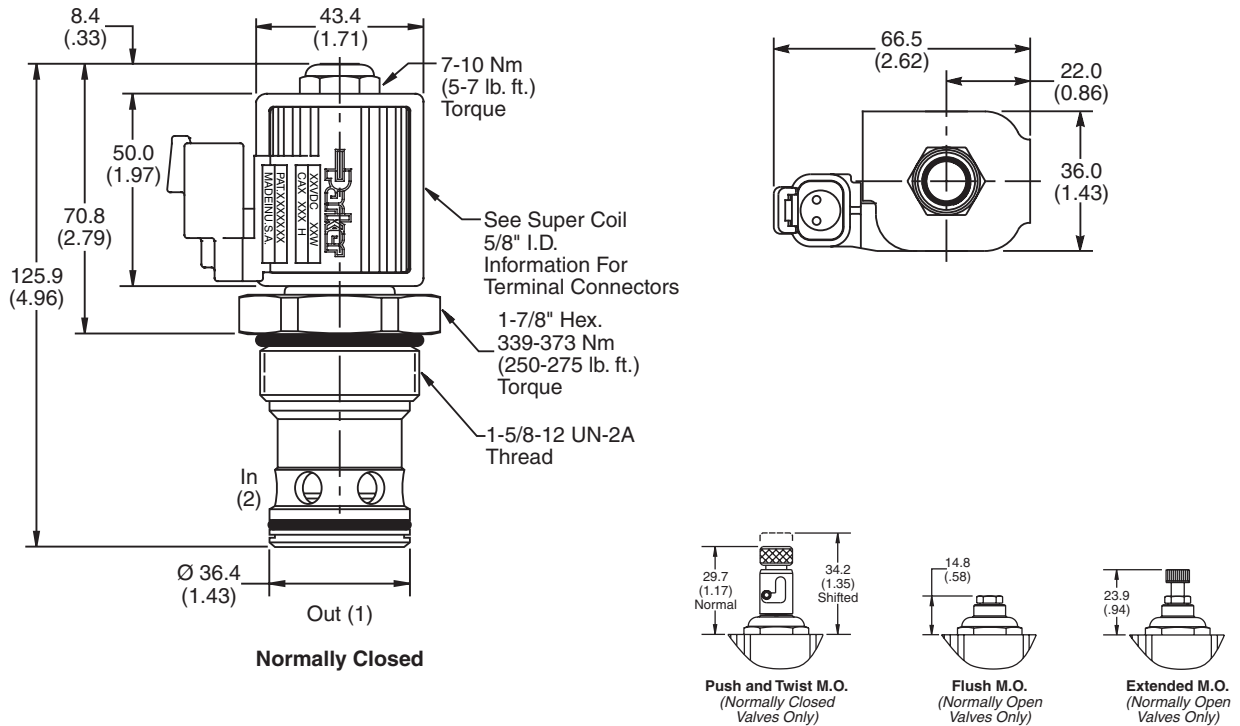

Ordering Information

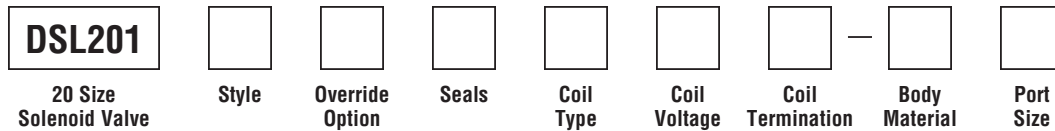

NOTE: This valve will be available January 1, 2011.

Code / Style	Symbol
C Normally Closed Metered reverse flow	
CR Normally Closed Free reverse flow	
N Normally Open Metered reverse flow	
NR Normally Open Free reverse flow	

Code	Override Options
Omit	None
E	Push Type with Extended Rod (N.O. Only)
M	Push Type with Flush Rod (N.O. Only)
T	Push & Twist (N.C. Only)

Code	Seals / Kit. No.
Omit	Nitrile / (SK20-2)
V	Fluorocarbon / (SK20-2V)

Code	Coil Type
Omit	Without Coil
SP*	Super Coil - 28 Watts

Code	Coil Voltage
Omit	Without Coil
D012	12 VDC
D024	24 VDC
A120	120/110 VAC, 60/50 Hz
A240	240/220 VAC, 60/50 Hz

SP* Coil	Coil Termination
Omit	Without Coil
C	Conduit With Leads
D	DIN Plug Face
A	Amp Jr. Timer†
S	Dual Spade†
L	Dual Lead Wire†
LS	Sealed Lead Wire†
H	Molded Deutsch†

Code	Body Material
Omit	Steel
A	Aluminum

Code	Port Size	Body Part No.
Omit	Cartridge Only	
20T	SAE-20	(B20-2-*20T)
20B	1-1/4" BSPG	(B20-2-*20B)

* Add "A" for aluminum, omit for steel.

*Recommended †DC Only

- CV**
Check Valves
- SH**
Shuttle Valves
- LM**
Load/Motor Controls
- FC**
Flow Controls
- PC**
Pressure Controls
- LE**
Logic Elements
- DC**
Directional Controls
- MV**
Manual Valves
- SV**
Solenoid Valves
- PV**
Proportional Valves
- CE**
Coils & Electronics
- BC**
Bodies & Cavities
- TD**
Technical Data

Technical Information

- CV** Check Valves
- SH** Shuttle Valves
- LM** Load/Motor Controls
- FC** Flow Controls
- PC** Pressure Controls
- LE** Logic Elements
- DC** Directional Controls
- MV** Manual Valves
- SV** Solenoid Valves
- PV** Proportional Valves
- CE** Coils & Electronics
- BC** Bodies & Cavities
- TD** Technical Data

General Description

2-Way, 2 Position, Normally Closed Poppet Valve With Flow Control Adjustment. This valve maintains constant flow at $\Delta P \geq 20$ Bar (300 PSI) regardless of load pressure changes upstream of the valve at port 2.

Features

- Light weight alloy housing with hardened steel moving parts
- One piece cartridge housing ensures internal concentricity
- Coil: Waterproof, hermetically sealed, requires no O’Rings; Coil is interchangeable with 04 and 06 series poppet valves; Symmetrical coil can be reversed without affecting performance.

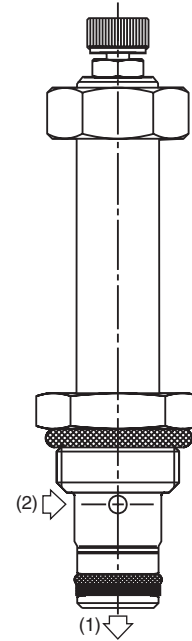
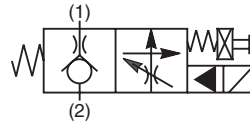

Specifications

Rated Flow (At 70 PSI ΔP)	9.5 LPM (2.5 GPM)
Maximum Inlet Pressure	High Pressure 285 Bar (4000 PSI)
Leakage at 150 SSU (32 cSt)	5 drops/min. (.33 cc/min.)
Minimum Operating Voltage	85% of rated voltage at 20°C (72°F).
Response Time	Open 20 ms Close 25 ms
Cartridge Material	All parts steel. All operating parts hardened steel.
Operating Temp. Range/Seals	-40°C to +93.3°C (Nitrile) (-40°F to +200°F) -31.7°C to +121.1°C (Fluorocarbon) (-25°F to +250°F)
Fluid Compatibility/ Viscosity	Mineral-based or synthetic with lubricating properties at viscosities of 45 to 2000 SSU (6 to 420 cSt)
Filtration	ISO Code 16/13, SAE Class 4 or better
Approx. Weight	.09 kg (.19 lbs.)
Cavity	C08-2 (See BC Section for more details)

Performance Curves

(Through cartridge only)

Pressure Compensation For Different Flow Settings

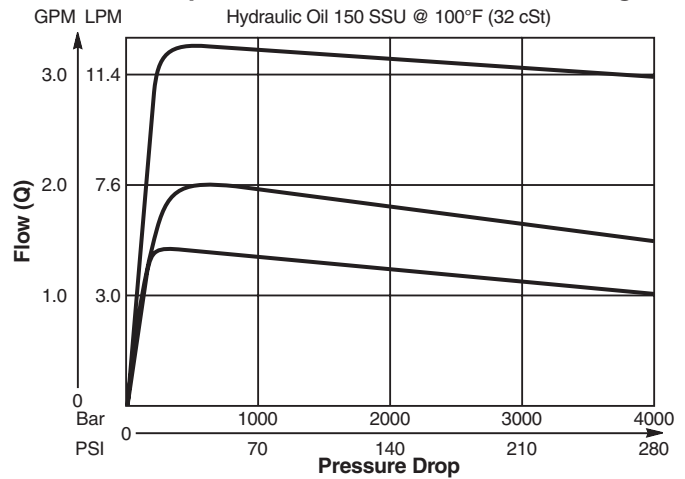

Reverse Flow

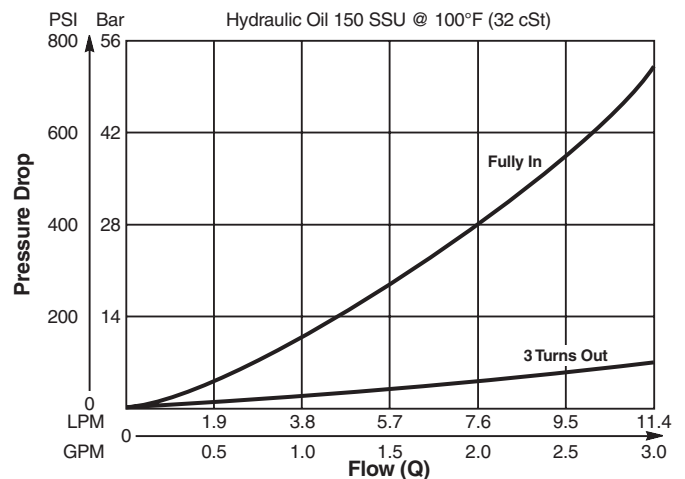

Dimensions Millimeters (Inches)

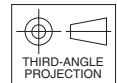
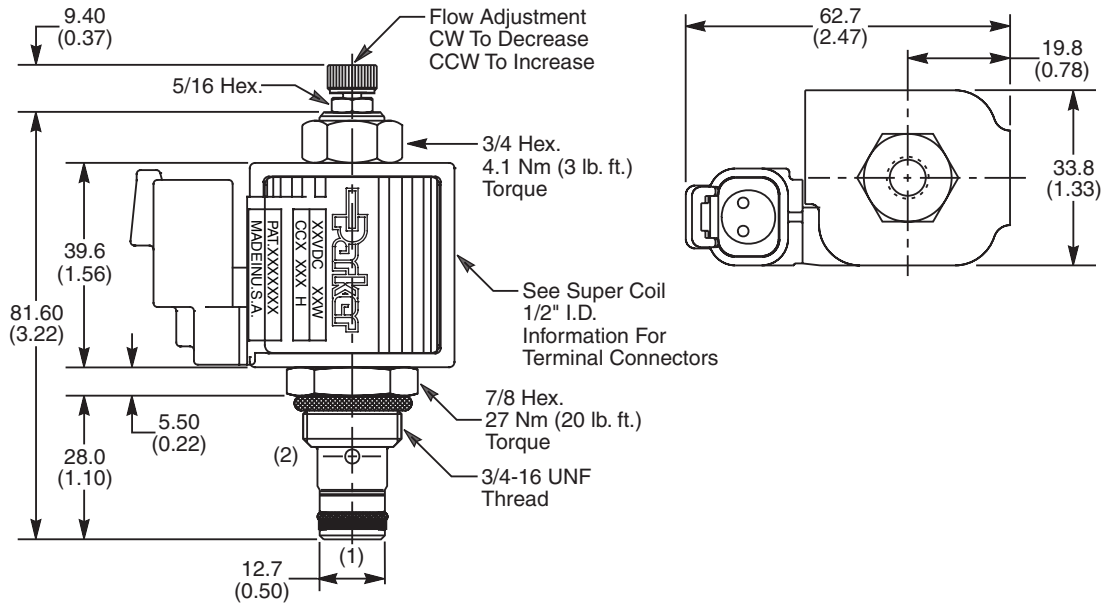

Ordering Information

GH02 **01** -

08 Size Solenoid Valve Style Normally Closed Screen Seals Coil Type Coil Voltage Coil Termination Body Material Port Size

Code	Style
01	High Pressure ('SP' Coil)

Code	Screen
0	None
1	60 Mesh Screen

Code	Seals / Kit No.
N	Nitrile / Buna-N (Std.) (SK30006N-1)
V	Fluorocarbon / (SK30006V-1)

Code	Coil Type
Omit	Without Coil
SP	Super Coil - 19 Watts

Code	Coil Voltage
Omit	Without Coil
D012	12 VDC
D024	24 VDC
A120	120 VAC, 60/50 Hz
A240	240 VAC, 60/50 Hz*

*22 Watts

Code	Coil Termination
Omit	Without Coil
C	Conduit With Leads
D	DIN Plug Face
A	Amp Jr. Timer*
S	Dual Spade*
L	Dual Lead Wire*
LS	Sealed Lead Wire*
H	Molded Deutsch*

See Super Coil 1/2" I.D.
*DC Only

Code	Body Material
Omit	Steel
A	Aluminum

Code	Port Size	Body Part No.
Omit		Cartridge Only
6T	SAE-6	(B08-2-*6T)
6B	3/8" BSPG	(B08-2-*6B)

* Add "A" for aluminum, omit for steel.

- CV**
Check Valves
- SH**
Shuttle Valves
- LM**
Load/Motor Controls
- FC**
Flow Controls
- PC**
Pressure Controls
- LE**
Logic Elements
- DC**
Directional Controls
- MV**
Manual Valves
- SV**
Solenoid Valves
- PV**
Proportional Valves
- CE**
Coils & Electronics
- BC**
Bodies & Cavities
- TD**
Technical Data

Technical Information

- CV** Check Valves
- SH** Shuttle Valves
- LM** Load/Motor Controls
- FC** Flow Controls
- PC** Pressure Controls
- LE** Logic Elements
- DC** Directional Controls
- MV** Manual Valves
- SV** Solenoid Valves
- PV** Proportional Valves
- CE** Coils & Electronics
- BC** Bodies & Cavities
- TD** Technical Data

General Description

2-Way, 2 Position, Normally Closed Poppet Valve. Bi-Directional Direct Acting. For additional information see Technical Tips on pages SV1-SV6.

Features

- Fast Response
- One piece cartridge housing ensures internal concentricity
- Coil: Waterproof, hermetically sealed, requires no O’Rings; Coil is interchangeable with 04 and 06 series poppet valves; Symmetrical coil can be reversed without affecting performance.

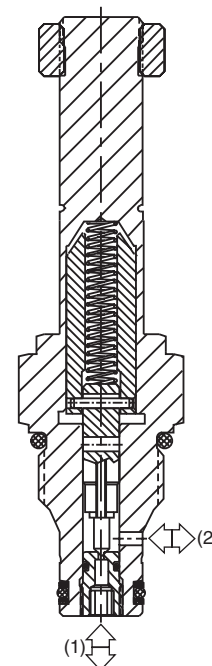
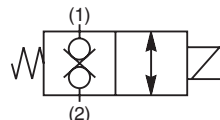

Specifications

Rated Flow (At 70 PSI ΔP)	1 LPM (0.26 GPM)
Maximum Inlet Pressure	210 Bar (3000 PSI)
Leakage at 150 SSU (32 cSt)	72 5 drops/min. (.33 cc/min.) 73 Zero Drops Soft (Delrin) Seat
Minimum Operating Voltage	85% of rated voltage at 20°C (72°F).
Response Time	Open 10 ms Close 10 ms
Cartridge Material	All parts steel. All operating parts hardened steel.
Operating Temp. Range/Seals	-40°C to +93.3°C (Nitrile) (-40°F to +200°F) -31.7°C to +121.1°C (Fluorocarbon) (-25°F to +250°F)
Fluid Compatibility/ Viscosity	Mineral-based or synthetic with lubricating properties at viscosities of 45 to 2000 SSU (6 to 420 cSt)
Filtration	ISO Code 16/13, SAE Class 4 or better
Approx. Weight	.14 kg (.31 lbs.)
Cavity	C08-2 (See BC Section for more details)

Performance Curve

Pressure Drop vs. Flow (Through cartridge only)

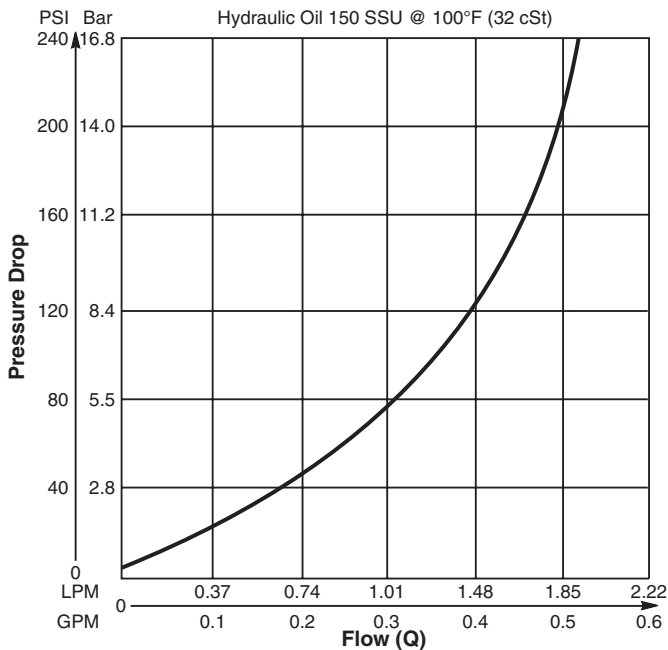

Technical Information

Dimensions Millimeters (Inches)

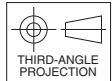
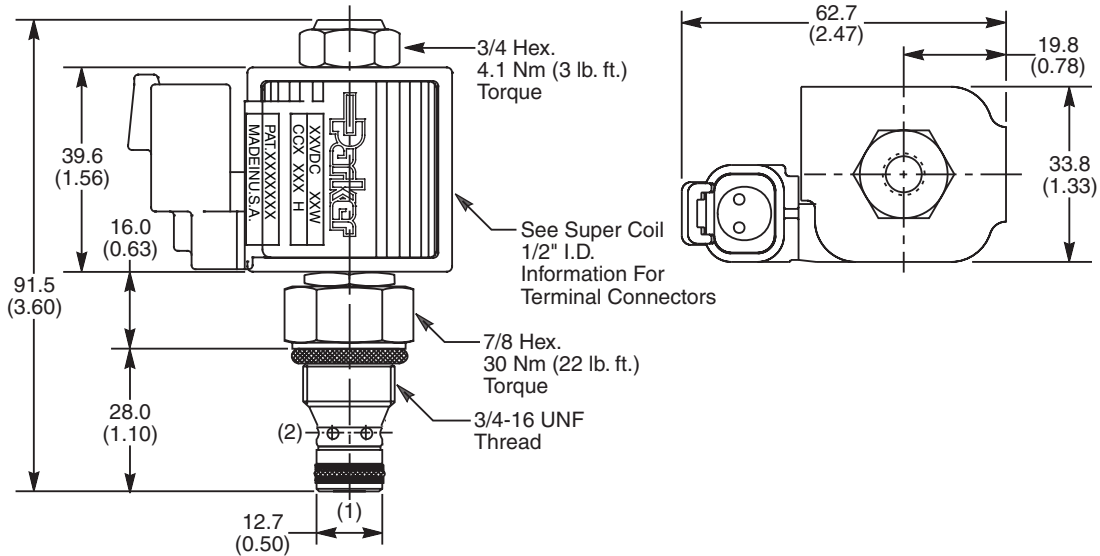

Ordering Information

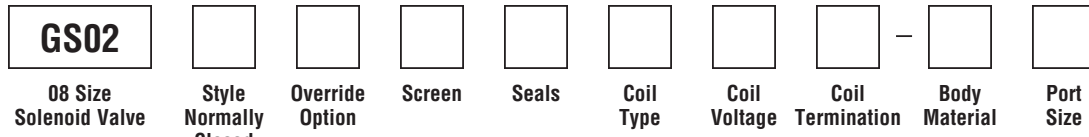

Code	Style
72	Standard ('SP' Coil)
73	Zero Drops ('SP' Coil)

Code	Seals / Kit No.
N	Nitrile / Buna-N (Std.) (SK30088N-1)
V	Fluorocarbon / (SK30088V-1)

Code	Coil Termination
Omit	Without Coil
C	Conduit With Leads
D	DIN Plug Face
A	Amp Jr. Timer*
S	Dual Spade*
L	Dual Lead Wire*
LS	Sealed Lead Wire*
H	Molded Deutsch*

Code	Body Material
Omit	Steel
A	Aluminum

Code	Override Options
0	None

Code	Coil Type
Omit	Without Coil
SP	Super Coil - 19 Watts

Code	Port Size	Body Part No.
Omit	Cartridge Only	
6T	SAE-6	(B08-2-*6T)
6B	3/8" BSPG	(B08-2-*6B)

* Add "A" for aluminum, omit for steel.

Code	Screen
0	None
1	60 Mesh Screen

Code	Coil Voltage
Omit	Without Coil
D012	12 VDC
D024	24 VDC
A120	120 VAC, 60/50 Hz
A240	240 VAC, 60/50 Hz*

*22 Watts

See Super Coil 1/2" I.D.
*DC Only

- CV Check Valves
- SH Shuttle Valves
- LM Load/Motor Controls
- FC Flow Controls
- PC Pressure Controls
- LE Logic Elements
- DC Directional Controls
- MV Manual Valves
- SV Solenoid Valves
- PV Proportional Valves
- CE Coils & Electronics
- BC Bodies & Cavities
- TD Technical Data

Technical Information

- CV** Check Valves
- SH** Shuttle Valves
- LM** Load/Motor Controls
- FC** Flow Controls
- PC** Pressure Controls
- LE** Logic Elements
- DC** Directional Controls
- MV** Manual Valves
- SV** Solenoid Valves
- PV** Proportional Valves
- CE** Coils & Electronics
- BC** Bodies & Cavities
- TD** Technical Data

General Description

2-Way, 2 Position, Normally Closed, Bi-Directional Poppet Valve. For additional information see Technical Tips on pages SV1-SV6.

Features

- Built-in thermal relief set at 36 Bar (500 PSI) above rated pressure
- One piece cartridge housing ensures internal concentricity
- Coil: Waterproof, hermetically sealed, requires no O’Rings; Coil is interchangeable with 04 and 06 series poppet valves; Symmetrical coil can be reversed without affecting performance.

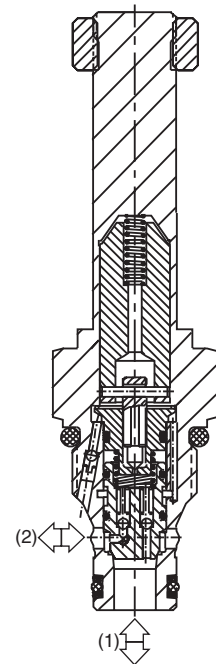
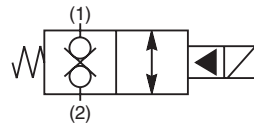

Specifications

Rated Flow (At 70 PSI ΔP)	2 to 1 34 LPM (9 GPM) 1 to 2 19 LPM (5 GPM)
Maximum Inlet Pressure	80 210 Bar (3000 PSI) 81 350 Bar (5000 PSI)
Leakage at 150 SSU (32 cSt)	5 drops/min. (.33 cc/min.)
Minimum Operating Voltage	85% of rated voltage at 20°C (72°F).
Response Time	Open 40 ms Close 40 ms
Cartridge Material	All parts steel. All operating parts hardened steel.
Operating Temp. Range/Seals	-40°C to +93.3°C (Nitrile) (-40°F to +200°F) -31.7°C to +121.1°C (Fluorocarbon) (-25°F to +250°F)
Fluid Compatibility/ Viscosity	Mineral-based or synthetic with lubricating properties at viscosities of 45 to 2000 SSU (6 to 420 cSt)
Filtration	ISO Code 16/13, SAE Class 4 or better
Approx. Weight	.14 kg (.31 lbs.)
Cavity	C08-2 (See BC Section for more details)

Performance Curve

Pressure Drop vs. Flow (Through cartridge only)

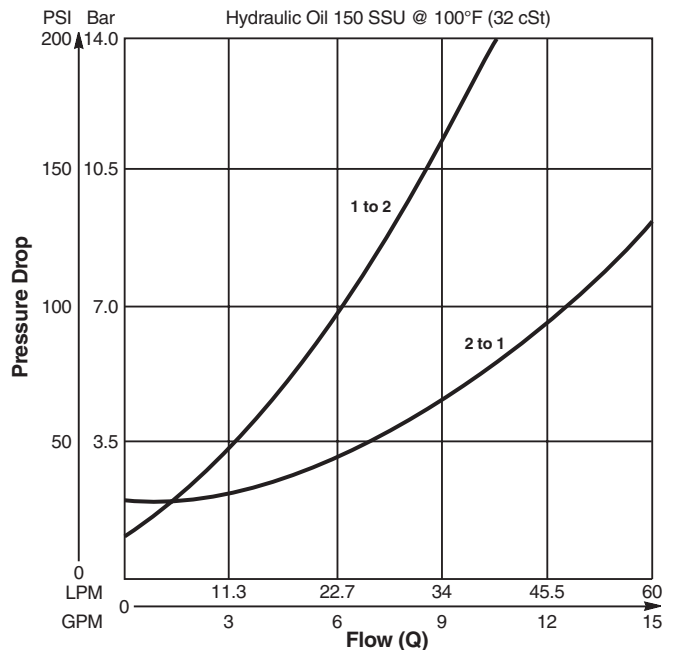

Technical Information

Dimensions Millimeters (Inches)

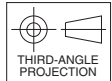
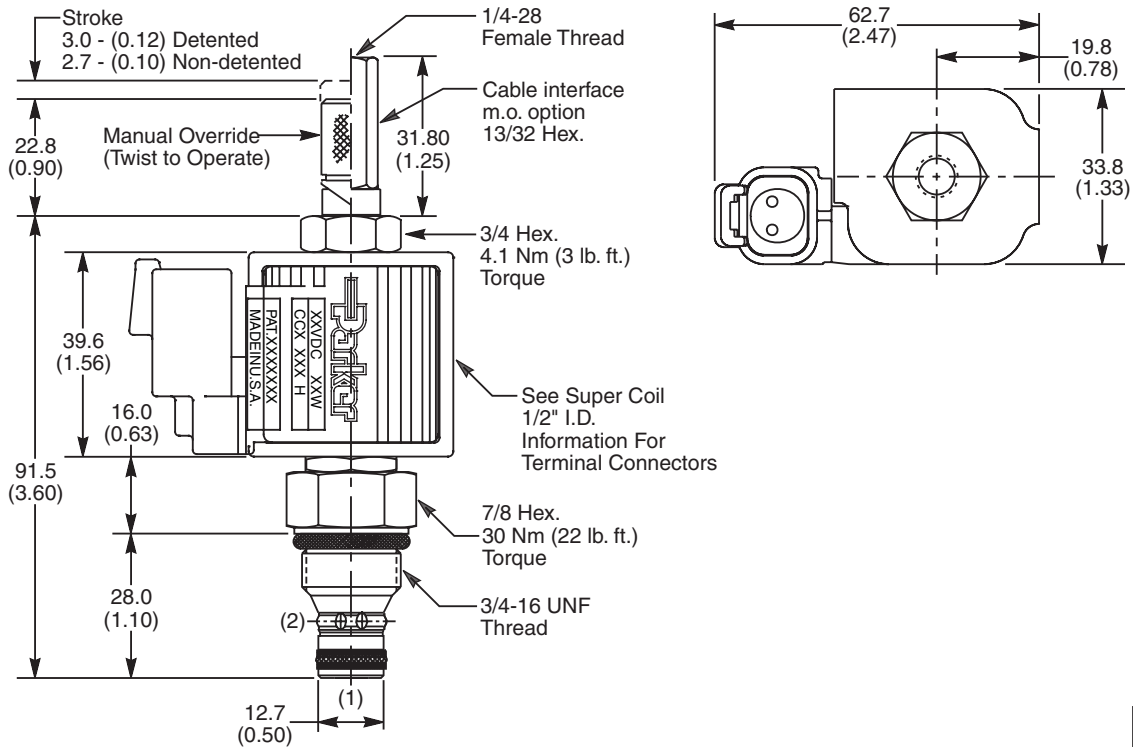

Ordering Information

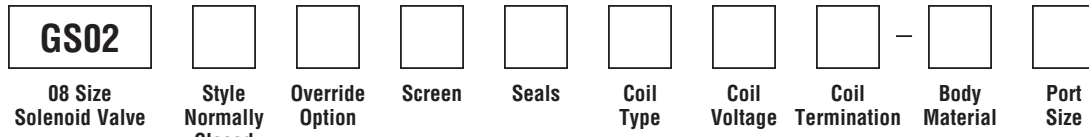

Code	Style
80	Standard ('SS' Coil)
81	High Pressure ('SP' Coil)

Code	Seals / Kit No.
N	Nitrile / Buna-N (Std.) (SK30088N-1)

Code	Coil Termination
Omit	Without Coil
C	Conduit With Leads
D	DIN Plug Face
A	Amp Jr. Timer*
S	Dual Spade*
L	Dual Lead Wire*
LS	Sealed Lead Wire*
H	Molded Deutsch*

Code	Body Material
Omit	Steel
A	Aluminum

Code	Override Options
0	None
1	Detented
2	Non-Detented
3	Cable Interface 210 Bar (3000 PSI)

Code	Coil Type
Omit	Without Coil
SS	Super Coil - 14 Watts
SP	Super Coil - 19 Watts

Code	Port Size	Body Part No.
Omit	Cartridge Only	
6T	SAE-6	(B08-2-*6T)
6B	3/8" BSPG	(B08-2-*6B)

Code	Coil Voltage
Omit	Without Coil
D012	12 VDC
D024	24 VDC
A120	120 VAC, 60/50 Hz
A240	240 VAC, 60/50 Hz*

*22 Watts

See Super Coil 1/2" I.D.
*DC Only

* Add "A" for aluminum, omit for steel.

Technical Information

- CV** Check Valves
- SH** Shuttle Valves
- LM** Load/Motor Controls
- FC** Flow Controls
- PC** Pressure Controls
- LE** Logic Elements
- DC** Directional Controls
- MV** Manual Valves
- SV** Solenoid Valves
- PV** Proportional Valves
- CE** Coils & Electronics
- BC** Bodies & Cavities
- TD** Technical Data

General Description

2-Way, 2 Position, Normally Closed, Bi-Directional Poppet Valve. For additional information see Technical Tips on pages SV1-SV6.

Features

- Built-in thermal relief set at 36 Bar (500 PSI) above rated pressure
- One piece cartridge housing ensures internal concentricity
- Coil: Waterproof, hermetically sealed, requires no O’Rings; Coil is interchangeable with 02 and 06 series poppet valves; Symmetrical coil can be reversed without affecting performance.

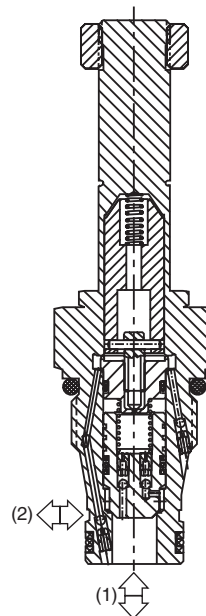
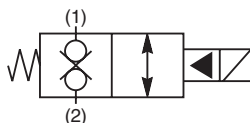

Specifications

Rated Flow (At 70 PSI ΔP)	2 to 1 68 LPM (18 GPM) 1 to 2 46 LPM (12 GPM)
Maximum Inlet Pressure	80 210 Bar (3000 PSI) 81 350 Bar (5000 PSI)
Leakage at 150 SSU (32 cSt)	5 drops/min. (.33 cc/min.)
Minimum Operating Voltage	85% of rated voltage at 20°C (72°F).
Response Time	See Performance Curves
Cartridge Material	All parts steel. All operating parts hardened steel.
Operating Temp. Range/Seals	-40°C to +93.3°C (Nitrile) (-40°F to +200°F) -31.7°C to +121.1°C (Fluorocarbon) (-25°F to +250°F)
Fluid Compatibility/Viscosity	Mineral-based or synthetic with lubricating properties at viscosities of 45 to 2000 SSU (6 to 420 cSt)
Filtration	ISO Code 16/13, SAE Class 4 or better
Approx. Weight	.17 kg (.37 lbs.)
Cavity	2R (See BC Section for more details)

Performance Curves

Pressure Drop vs. Flow (Through cartridge only)

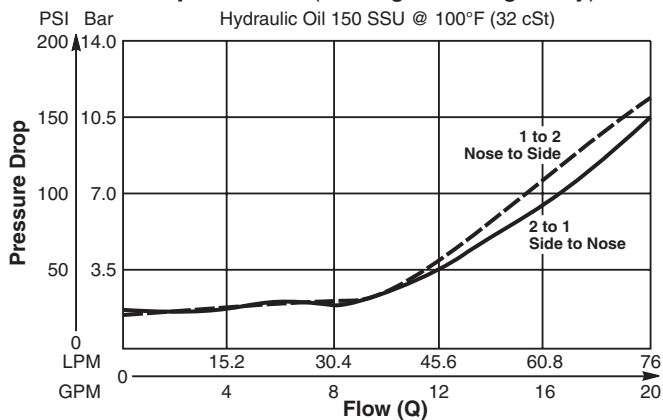

Response Time vs. Flow

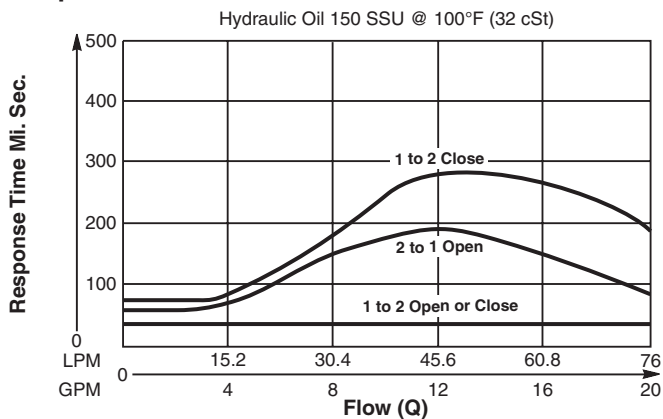

Technical Information

Dimensions Millimeters (Inches)

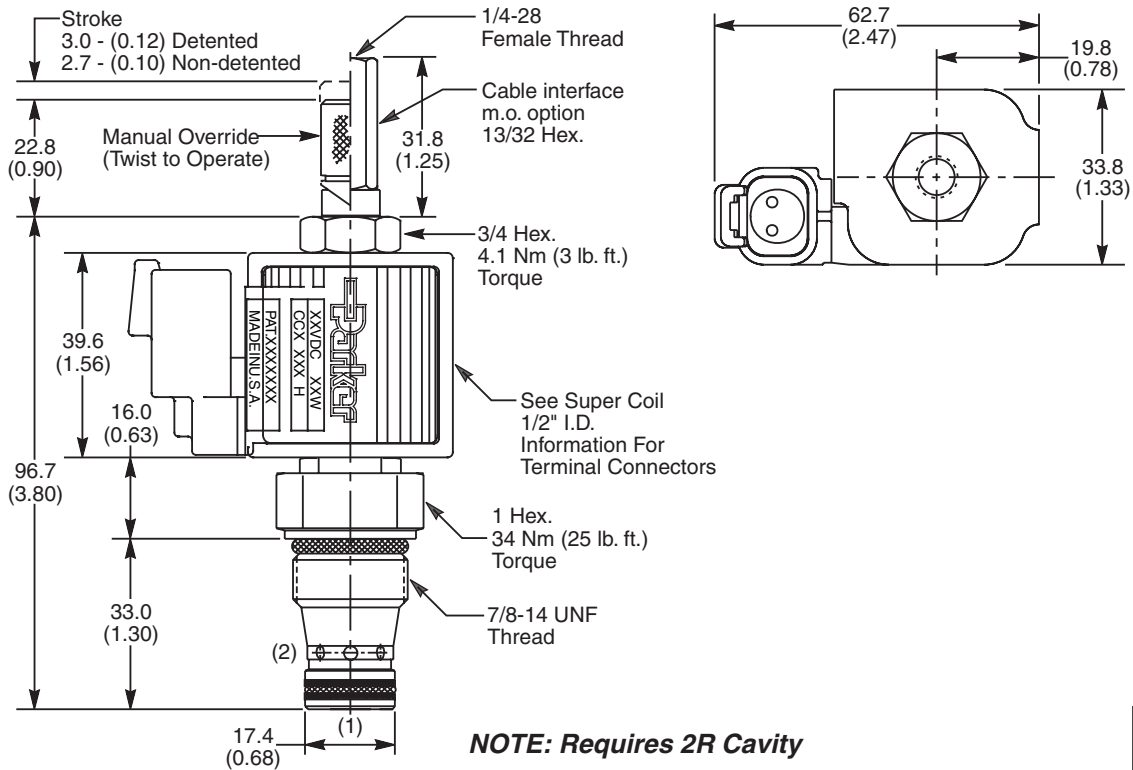

Ordering Information

GS04

10 Size Solenoid Valve Style Normally Closed Override Option Screen Seals Coil Type Coil Voltage Coil Termination

Code	Style
80	Standard ('SS' Coil)
81	High Pressure ('SP' Coil)

Code	Seals / Kit No.
N	Nitrile / Buna-N (Std.) (SK30113N-1)

Code	Coil Termination
Omit	Without Coil
C	Conduit With Leads
D	DIN Plug Face
A	Amp Jr. Timer*
S	Dual Spade*
L	Dual Lead Wire*
LS	Sealed Lead Wire*
H	Molded Deutsch*

See Super Coil 1/2" I.D.
*DC Only

Code	Override Options
0	None
1	Detented
2	Non-Detented
3	Cable Interface 210 Bar (3000 PSI)

Code	Coil Type
Omit	Without Coil
SS	Super Coil - 14 Watts
SP	Super Coil - 19 Watts

Code	Coil Voltage
Omit	Without Coil
D012	12 VDC
D024	24 VDC
A120	120 VAC, 60/50 Hz
A240	240 VAC, 60/50 Hz*

*22 Watts

Code	Screen
0	None

Order Bodies Separately

LB10

Line Body Porting Body Material

Code	Porting
543	1/2" SAE
545	1/2" BSP

Code	Body Material
A	Aluminum
S	Steel

- CV Check Valves
- SH Shuttle Valves
- LM Load/Motor Controls
- FC Flow Controls
- PC Pressure Controls
- LE Logic Elements
- DC Directional Controls
- MV Manual Valves
- SV Solenoid Valves
- PV Proportional Valves
- CE Coils & Electronics
- BC Bodies & Cavities
- TD Technical Data

Technical Information

- CV** Check Valves
- SH** Shuttle Valves
- LM** Load/Motor Controls
- FC** Flow Controls
- PC** Pressure Controls
- LE** Logic Elements
- DC** Directional Controls
- MV** Manual Valves
- SV** Solenoid Valves
- PV** Proportional Valves
- CE** Coils & Electronics
- BC** Bodies & Cavities
- TD** Technical Data

General Description

2-Way, 2 Position, Normally Closed, Bi-Directional Poppet Valve. For additional information see Technical Tips on pages SV1-SV6.

Features

- Built-in thermal relief set at 36 Bar (500 PSI) above rated pressure
- One piece cartridge housing ensures internal concentricity
- Coil: Waterproof, hermetically sealed, requires no O’Rings; Coil is interchangeable with 02 and 04 series poppet valves; Symmetrical coil can be reversed without affecting performance.

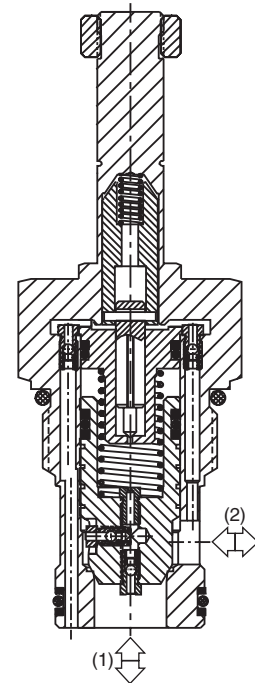
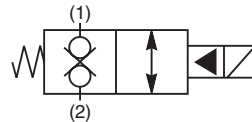

Specifications

Rated Flow (At 70 PSI ΔP)	190 LPM (50 GPM)
Maximum Inlet Pressure	80 210 Bar (3000 PSI) 81 350 Bar (5000 PSI)
Leakage at 150 SSU (32 cSt)	9 drops/min. (.58 cc/min.)
Minimum Operating Voltage	85% of rated voltage at 20°C (72°F).
Response Time	See Performance Curves
Cartridge Material	All parts steel. All operating parts hardened steel.
Operating Temp. Range/Seals	-40°C to +93.3°C (Nitrile) (-40°F to +200°F) -31.7°C to +121.1°C (Fluorocarbon) (-25°F to +250°F)
Fluid Compatibility/ Viscosity	Mineral-based or synthetic with lubricating properties at viscosities of 45 to 2000 SSU (6 to 420 cSt)
Filtration	ISO Code 16/13, SAE Class 4 or better
Approx. Weight	0.4 kg (.88 lbs.)
Cavity	C16-2 (See BC Section for more details)

Performance Curves

Pressure Drop vs. Flow (Through cartridge only)

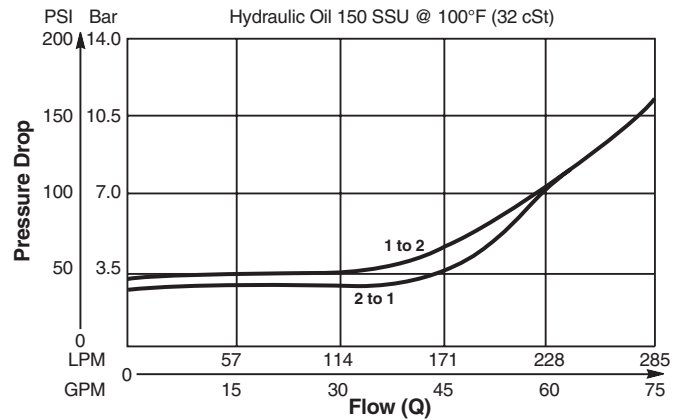

Response Time vs. Flow

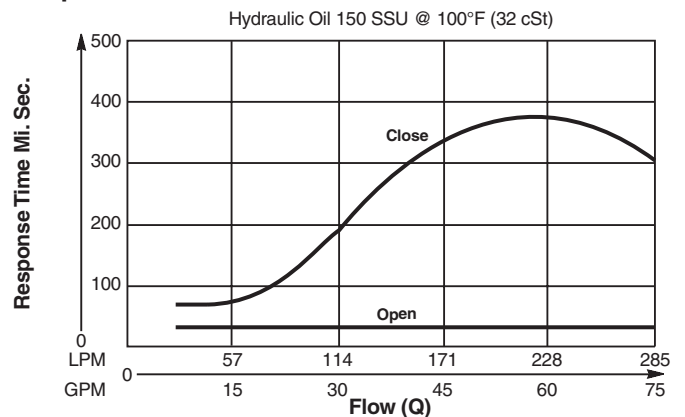

Technical Information

Dimensions Millimeters (Inches)

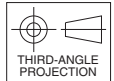
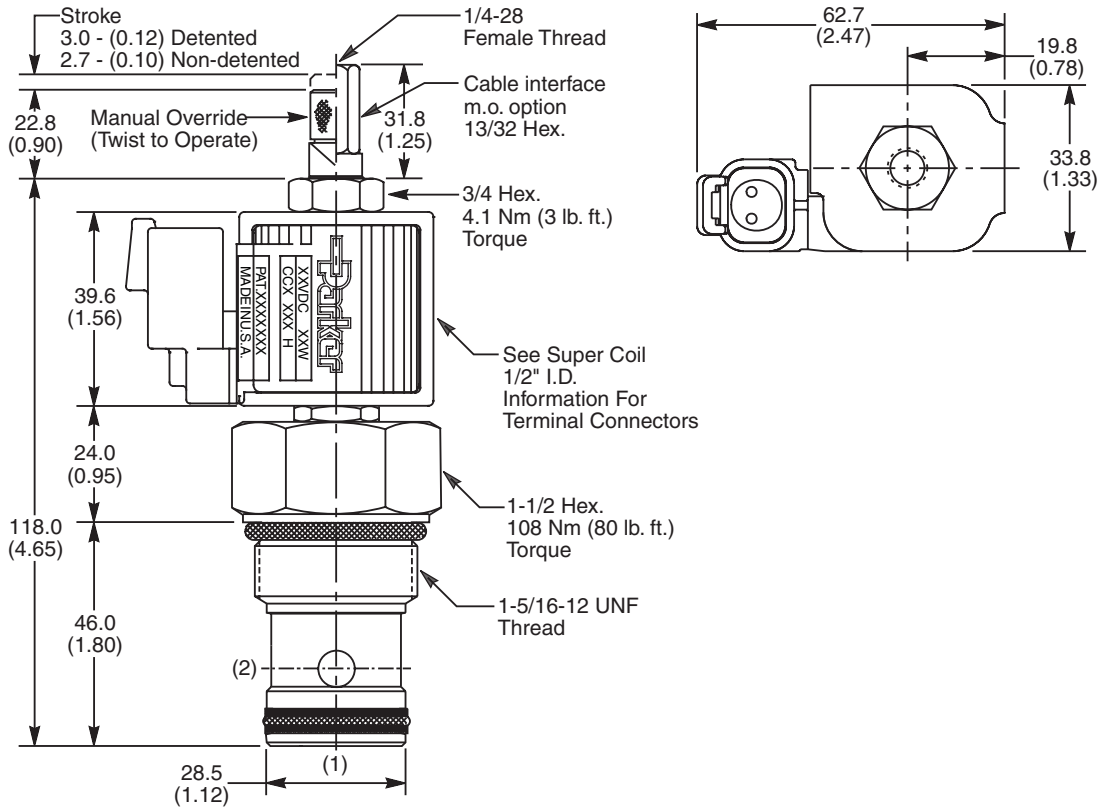

Ordering Information

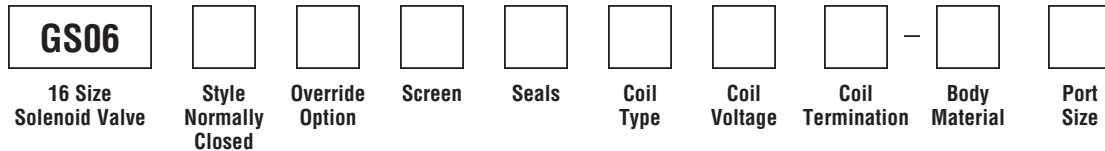

Code	Style
80	Standard ('SS' Coil)
81	High Pressure ('SP' Coil)

Code	Seals / Kit No.
N	Nitrile / Buna-N (Std.) (SK30089N-1)
V	Fluorocarbon / (SK30089V-1)

Code	Coil Termination
Omit	Without Coil
C	Conduit With Leads
D	DIN Plug Face
A	Amp Jr. Timer*
S	Dual Spade*
L	Dual Lead Wire*
LS	Sealed Lead Wire*
H	Molded Deutsch*

Code	Body Material
Omit	Steel
A	Aluminum

Code	Override Options
0	None
1	Detented
2	Non-Detented
3	Cable Interface 210 Bar (3000 PSI)

Code	Coil Type
Omit	Without Coil
SS	Super Coil - 14 Watts
SP	Super Coil - 19 Watts

Code	Port Size	Body Part No.
Omit	Cartridge Only	
16T	SAE-16	(B16-2-*16T)
16B	1" BSPG	(B16-2-16B)†

* Add "A" for aluminum, omit for steel.
† Steel body only.

Code	Screen
0	None

Code	Coil Voltage
Omit	Without Coil
D012	12 VDC
D024	24 VDC
A120	120 VAC, 60/50 Hz
A240	240 VAC, 60/50 Hz*

*22 Watts

See Super Coil 1/2" I.D.
*DC Only

Technical Information

- CV** Check Valves
- SH** Shuttle Valves
- LM** Load/Motor Controls
- FC** Flow Controls
- PC** Pressure Controls
- LE** Logic Elements
- DC** Directional Controls
- MV** Manual Valves
- SV** Solenoid Valves
- PV** Proportional Valves
- CE** Coils & Electronics
- BC** Bodies & Cavities
- TD** Technical Data

General Description

2-Way, 2 Position, Normally Open Poppet Valve. Bi-Directional Direct Acting. For additional information see Technical Tips on pages SV1-SV6.

Features

- Fast Response
- One piece cartridge housing ensures internal concentricity
- Coil: Waterproof, hermetically sealed, requires no O’Rings; Coil is interchangeable with 04 and 06 series poppet valves; Symmetrical coil can be reversed without affecting performance.

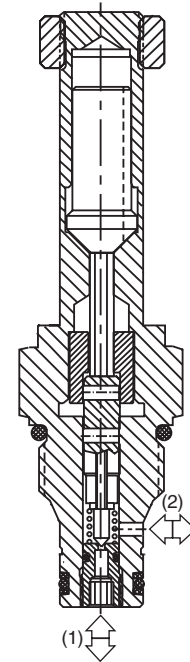
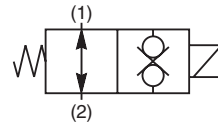

Specifications

Rated Flow (At 70 PSI ΔP)	1 LPM (0.26 GPM)
Maximum Inlet Pressure	210 Bar (3000 PSI)
Leakage at 150 SSU (32 cSt)	77 5 drops/min. (.33 cc/min.) 78 Zero Drops Soft (Delrin) Seat
Minimum Operating Voltage	85% of rated voltage at 20°C (72°F).
Response Time	Open 10 ms Close 10 ms
Cartridge Material	All parts steel. All operating parts hardened steel.
Operating Temp. Range/Seals	-40°C to +93.3°C (Nitrile) (-40°F to +200°F) -31.7°C to +121.1°C (Fluorocarbon) (-25°F to +250°F)
Fluid Compatibility/ Viscosity	Mineral-based or synthetic with lubricating properties at viscosities of 45 to 2000 SSU (6 to 420 cSt)
Filtration	ISO Code 16/13, SAE Class 4 or better
Approx. Weight	.14 kg (.31 lbs.)
Cavity	C08-2 (See BC Section for more details)

Performance Curve

Pressure Drop vs. Flow (Through cartridge only)

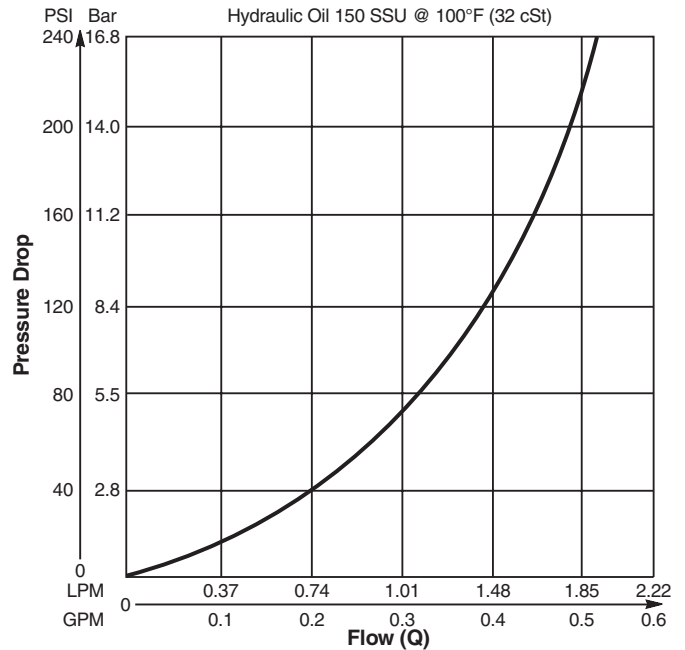

Technical Information

Dimensions Millimeters (Inches)

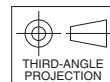
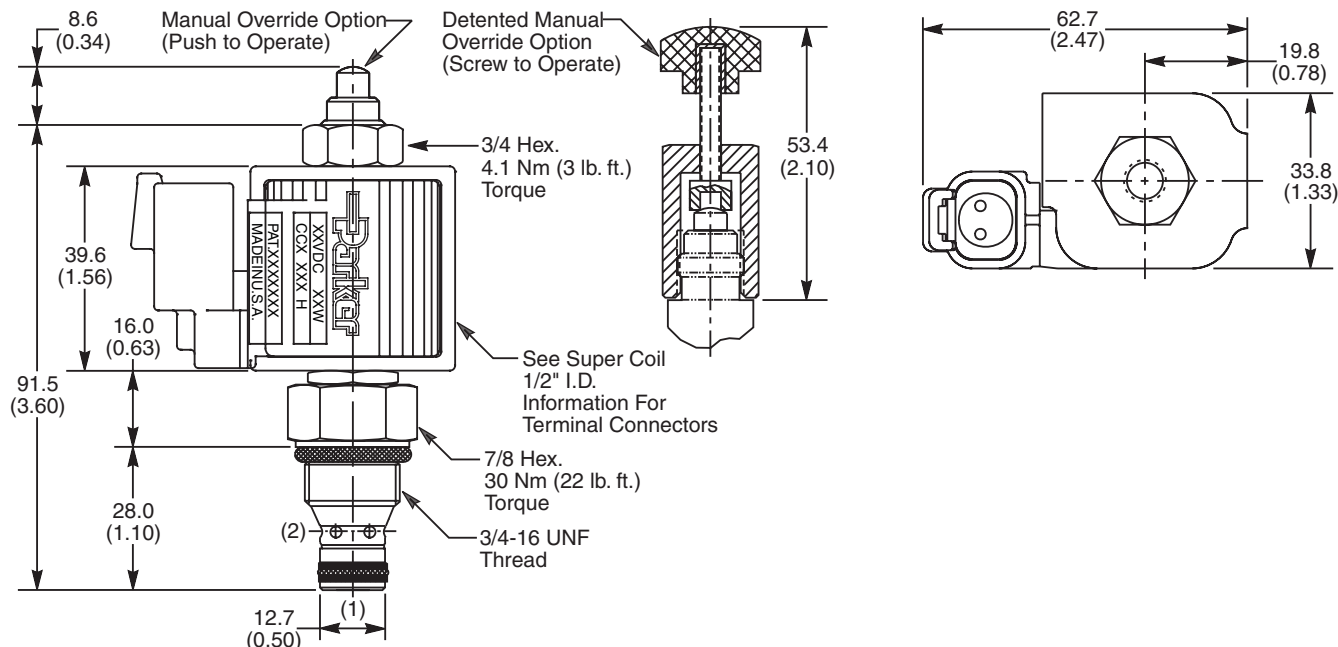

Ordering Information

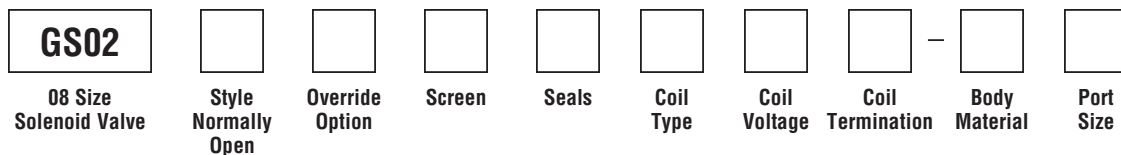

Code	Style
77	Standard ('SP' Coil)
78	Zero Drops ('SP' Coil)

Code	Seals / Kit No.
N	Nitrile / Buna-N (Std.) (SK30088N-1)
V	Fluorocarbon / (SK30088V-1)

Code	Coil Termination
Omit	Without Coil
C	Conduit With Leads
D	DIN Plug Face
A	Amp Jr. Timer*
S	Dual Spade*
L	Dual Lead Wire*
LS	Sealed Lead Wire*
H	Molded Deutsch*

Code	Body Material
Omit	Steel
A	Aluminum

Code	Override Options
0	None
1	Manual Override
2	Detented Part No. 900690

Code	Coil Type
Omit	Without Coil
SP	Super Coil - 19 Watts

Code	Port Size	Body Part No.
Omit	Cartridge Only	
6T	SAE-6	(B08-2-*6T)
6B	3/8" BSPG	(B08-2-*6B)

* Add "A" for aluminum, omit for steel.

Code	Screen
0	None
1	60 Mesh Screen

Code	Coil Voltage
Omit	Without Coil
D012	12 VDC
D024	24 VDC
A120	120 VAC, 60/50 Hz
A240	240 VAC, 60/50 Hz*

*22 Watts

See Super Coil 1/2" I.D.
*DC Only

- CV
Check Valves
- SH
Shuttle Valves
- LM
Load/Motor Controls
- FC
Flow Controls
- PC
Pressure Controls
- LE
Logic Elements
- DC
Directional Controls
- MV
Manual Valves
- SV
Solenoid Valves
- PV
Proportional Valves
- CE
Coils & Electronics
- BC
Bodies & Cavities
- TD
Technical Data

Technical Information

- CV** Check Valves
- SH** Shuttle Valves
- LM** Load/Motor Controls
- FC** Flow Controls
- PC** Pressure Controls
- LE** Logic Elements
- DC** Directional Controls
- MV** Manual Valves
- SV** Solenoid Valves
- PV** Proportional Valves
- CE** Coils & Electronics
- BC** Bodies & Cavities
- TD** Technical Data

General Description

2-Way, 2 Position, Normally Open, Bi-Directional Poppet Valve. For additional information see Technical Tips on pages SV1-SV6.

Features

- Built-in thermal relief set at 36 Bar (500 PSI) above rated pressure
- One piece cartridge housing ensures internal concentricity
- Coil: Waterproof, hermetically sealed, requires no O’Rings; Coil is interchangeable with 04 and 06 series poppet valves; Symmetrical coil can be reversed without affecting performance.

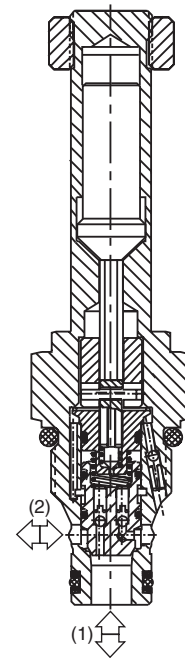
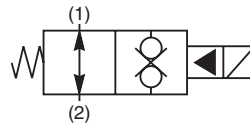

Specifications

Rated Flow (At 70 PSI ΔP)	2 to 1 34 LPM (9 GPM) 1 to 2 19 LPM (5 GPM)
Maximum Inlet Pressure	85 210 Bar (3000 PSI) 86 350 Bar (5000 PSI)
Leakage at 150 SSU (32 cSt)	5 drops/min. (.33 cc/min.)
Minimum Operating Voltage	85% of rated voltage at 20°C (72°F).
Response Time	Open 40 ms Close 40 ms
Cartridge Material	All parts steel. All operating parts hardened steel.
Operating Temp. Range/Seals	-40°C to +93.3°C (Nitrile) (-40°F to +200°F) -31.7°C to +121.1°C (Fluorocarbon) (-25°F to +250°F)
Fluid Compatibility/ Viscosity	Mineral-based or synthetic with lubricating properties at viscosities of 45 to 2000 SSU (6 to 420 cSt)
Filtration	ISO Code 16/13, SAE Class 4 or better
Approx. Weight	.14 kg (.31 lbs.)
Cavity	C08-2 (See BC Section for more details)

Performance Curve

Pressure Drop vs. Flow (Through cartridge only)

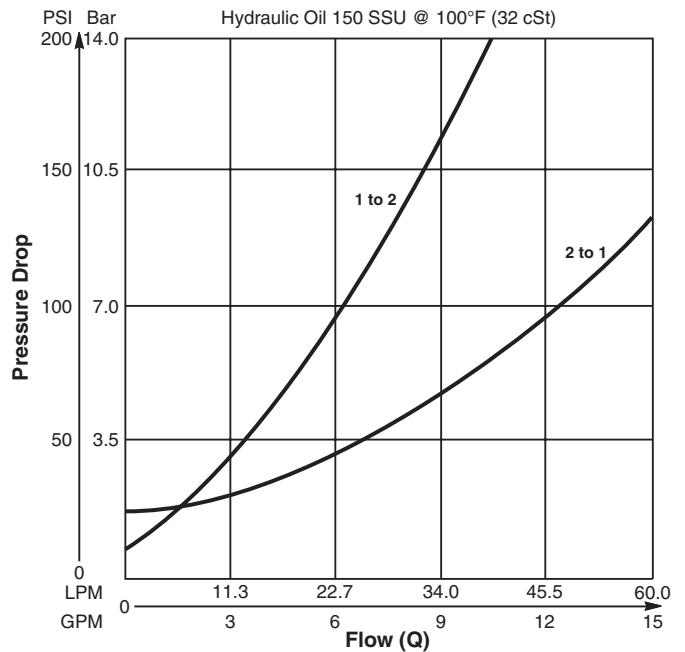

Technical Information

Dimensions Millimeters (Inches)

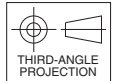
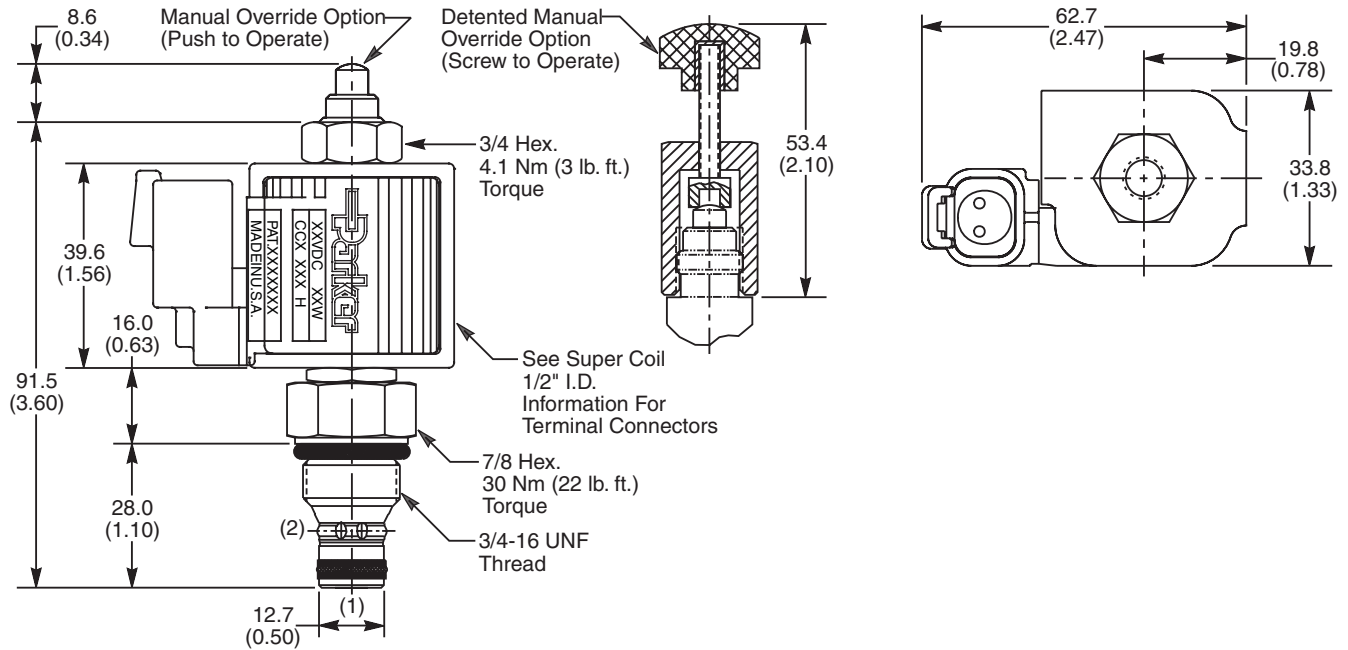

Ordering Information

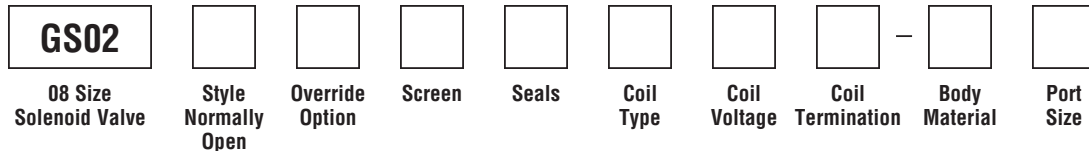

Code	Style
85	Standard ('SS' Coil)
86	High Pressure ('SP' Coil)

Code	Seals / Kit No.
N	Nitrile / Buna-N (Std.) (SK30088N-1)

Code	Coil Termination
Omit	Without Coil
C	Conduit With Leads
D	DIN Plug Face
A	Amp Jr. Timer*
S	Dual Spade*
L	Dual Lead Wire*
LS	Sealed Lead Wire*
H	Molded Deutsch*

Code	Body Material
Omit	Steel
A	Aluminum

Code	Override Options
0	None
1	Manual Override
2	Detented Part No. 900690

Code	Coil Type
Omit	Without Coil
SS	Super Coil - 14 Watts
SP	Super Coil - 19 Watts

Code	Port Size	Body Part No.
Omit	Cartridge Only	
6T	SAE-6	(B08-2-*6T)
6B	3/8" BSPG	(B08-2-*6B)

* Add "A" for aluminum, omit for steel.

Code	Screen
0	None

Code	Coil Voltage
Omit	Without Coil
D012	12 VDC
D024	24 VDC
A120	120 VAC, 60/50 Hz
A240	240 VAC, 60/50 Hz*

*22 Watts

See Super Coil 1/2" I.D.
*DC Only

- CV Check Valves
- SH Shuttle Valves
- LM Load/Motor Controls
- FC Flow Controls
- PC Pressure Controls
- LE Logic Elements
- DC Directional Controls
- MV Manual Valves
- SV Solenoid Valves
- PV Proportional Valves
- CE Coils & Electronics
- BC Bodies & Cavities
- TD Technical Data

Technical Information

- CV** Check Valves
- SH** Shuttle Valves
- LM** Load/Motor Controls
- FC** Flow Controls
- PC** Pressure Controls
- LE** Logic Elements
- DC** Directional Controls
- MV** Manual Valves
- SV** Solenoid Valves
- PV** Proportional Valves
- CE** Coils & Electronics
- BC** Bodies & Cavities
- TD** Technical Data

General Description

2-Way, 2 Position, Normally Open, Bi-Directional Poppet Valve. For additional information see Technical Tips on pages SV1-SV6.

Features

- Built-in thermal relief set at 36 Bar (500 PSI) above rated pressure
- One piece cartridge housing ensures internal concentricity
- Coil: Waterproof, hermetically sealed, requires no O’Rings; Coil is interchangeable with 02 and 06 series poppet valves; Symmetrical coil can be reversed without affecting performance.

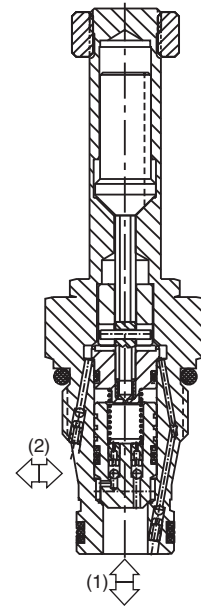
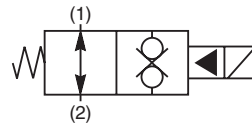
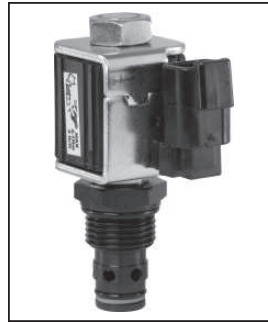

Specifications

Rated Flow (At 70 PSI ΔP)	2 to 1 68 LPM (18 GPM) 1 to 2 46 LPM (12 GPM)
Maximum Inlet Pressure	85 210 Bar (3000 PSI) 86 350 Bar (5000 PSI)
Leakage at 150 SSU (32 cSt)	5 drops/min. (.33 cc/min.)
Minimum Operating Voltage	85% of rated voltage at 20°C (72°F).
Response Time	See Performance Curves
Cartridge Material	All parts steel. All operating parts hardened steel.
Operating Temp. Range/Seals	-40°C to +93.3°C (Nitrile) (-40°F to +200°F) -31.7°C to +121.1°C (Fluorocarbon) (-25°F to +250°F)
Fluid Compatibility/Viscosity	Mineral-based or synthetic with lubricating properties at viscosities of 45 to 2000 SSU (6 to 420 cSt)
Filtration	ISO Code 16/13, SAE Class 4 or better
Approx. Weight	.17 kg (.37 lbs.)
Cavity	2R (See BC Section for more details)

Performance Curves

Pressure Drop vs. Flow (Through cartridge only)

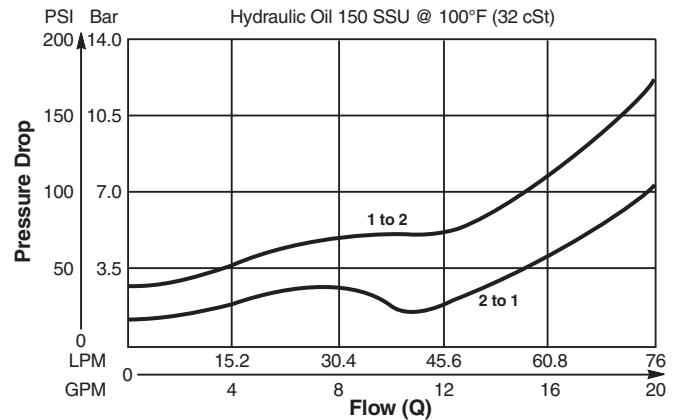

Response Time vs. Flow

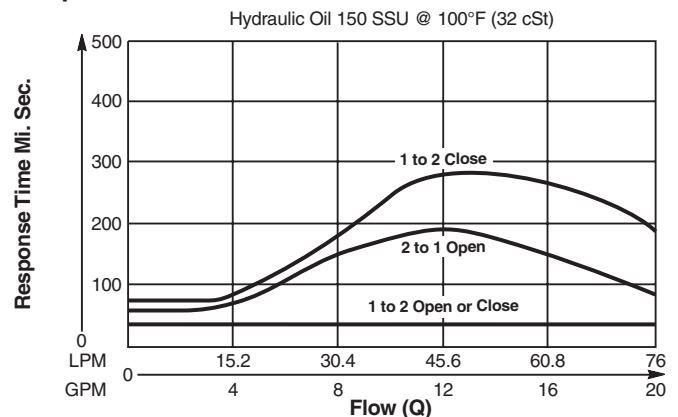

Technical Information

Dimensions Millimeters (Inches)

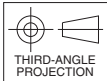
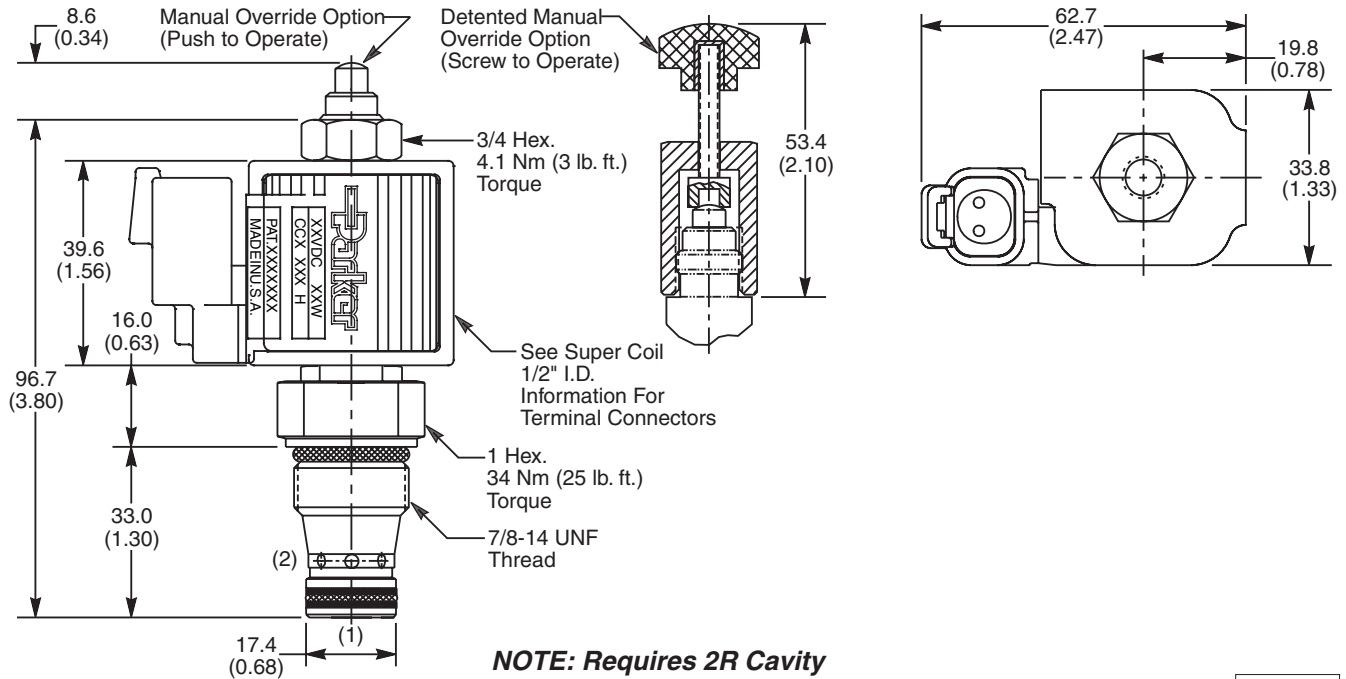

Ordering Information

GS04	<input type="checkbox"/>	<input type="checkbox"/>	<input type="checkbox"/>	<input type="checkbox"/>	<input type="checkbox"/>	<input type="checkbox"/>	<input type="checkbox"/>
10 Size Solenoid Valve	Style Normally Open	Override Option	Screen	Seals	Coil Type	Coil Voltage	Coil Termination

Code	Style
85	Standard ('SS' Coil)
86	High Pressure ('SP' Coil)

Code	Seals / Kit No.
N	Nitrile / Buna-N (Std.) (SK30113N-1)

Code	Coil Termination
Omit	Without Coil
C	Conduit With Leads
D	DIN Plug Face
A	Amp Jr. Timer*
S	Dual Spade*
L	Dual Lead Wire*
LS	Sealed Lead Wire*
H	Molded Deutsch*

See Super Coil 1/2" I.D.
*DC Only

Code	Override Options
0	None
1	Manual Override
2	Detented Part No. 900690

Code	Coil Type
Omit	Without Coil
SS	Super Coil - 14 Watts
SP	Super Coil - 19 Watts

Code	Screen
0	None

Code	Coil Voltage
Omit	Without Coil
D012	12 VDC
D024	24 VDC
A120	120 VAC, 60/50 Hz
A240	240 VAC, 60/50 Hz*

*22 Watts

Order Bodies Separately

LB10	<input type="checkbox"/>	<input type="checkbox"/>
Line Body	Porting	Body Material

Code	Porting
543	1/2" SAE
545	1/2" BSP

Code	Body Material
A	Aluminum
S	Steel



- CV
Check Valves
- SH
Shuttle Valves
- LM
Load/Motor Controls
- FC
Flow Controls
- PC
Pressure Controls
- LE
Logic Elements
- DC
Directional Controls
- MV
Manual Valves
- SV
Solenoid Valves
- PV
Proportional Valves
- CE
Coils & Electronics
- BC
Bodies & Cavities
- TD
Technical Data

Technical Information

- CV** Check Valves
- SH** Shuttle Valves
- LM** Load/Motor Controls
- FC** Flow Controls
- PC** Pressure Controls
- LE** Logic Elements
- DC** Directional Controls
- MV** Manual Valves
- SV** Solenoid Valves
- PV** Proportional Valves
- CE** Coils & Electronics
- BC** Bodies & Cavities
- TD** Technical Data

General Description

2-Way, 2 Position, Normally Open, Bi-Directional Poppet Valve. For additional information see Technical Tips on pages SV1-SV6.

Features

- Built-in thermal relief set at 36 Bar (500 PSI) above rated pressure
- One piece cartridge housing ensures internal concentricity
- Coil: Waterproof, hermetically sealed, requires no O’Rings; Coil is interchangeable with 02 and 04 series poppet valves; Symmetrical coil can be reversed without affecting performance.

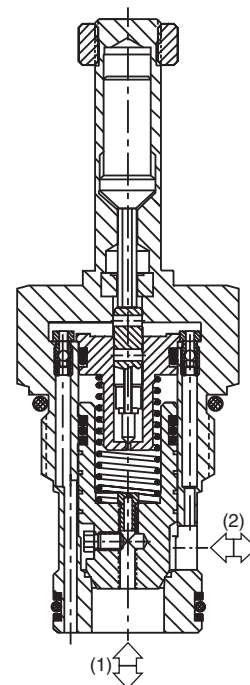
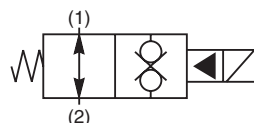

Specifications

Rated Flow (At 70 PSI ΔP)	190 LPM (50 GPM)
Maximum Inlet Pressure	85 210 Bar (3000 PSI) 86 350 Bar (5000 PSI)
Leakage at 150 SSU (32 cSt)	5 drops/min. (.33 cc/min.)
Minimum Operating Voltage	85% of rated voltage at 20°C (72°F).
Response Time	See Performance Curves
Cartridge Material	All parts steel. All operating parts hardened steel.
Operating Temp. Range/Seals	-40°C to +93.3°C (Nitrile) (-40°F to +200°F) -31.7°C to +121.1°C (Fluorocarbon) (-25°F to +250°F)
Fluid Compatibility/Viscosity	Mineral-based or synthetic with lubricating properties at viscosities of 45 to 2000 SSU (6 to 420 cSt)
Filtration	ISO Code 16/13, SAE Class 4 or better
Approx. Weight	0.4 kg (.88 lbs.)
Cavity	C16-2 (See BC Section for more details)

Performance Curves

Pressure Drop vs. Flow (Through cartridge only)

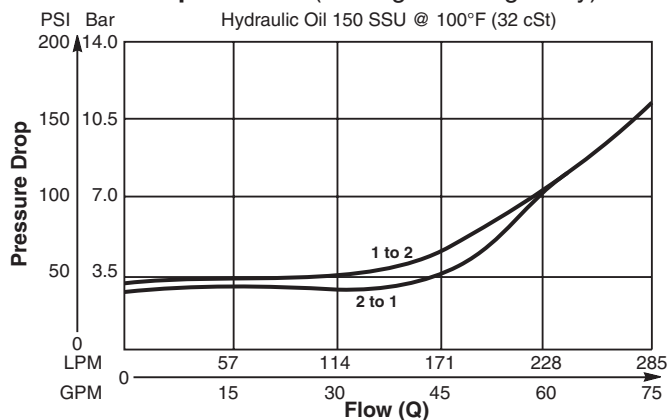

Response Time vs. Flow

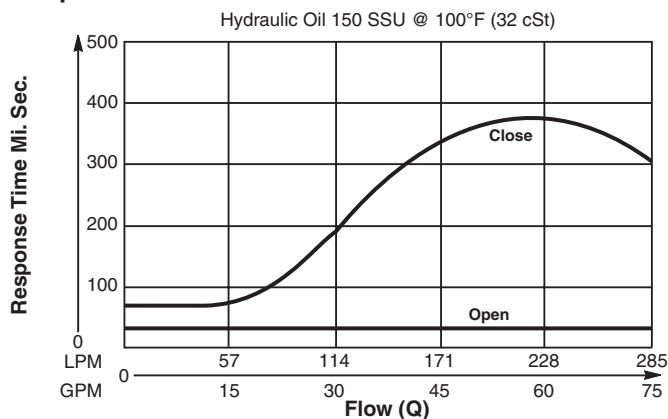

Technical Information

Dimensions Millimeters (Inches)

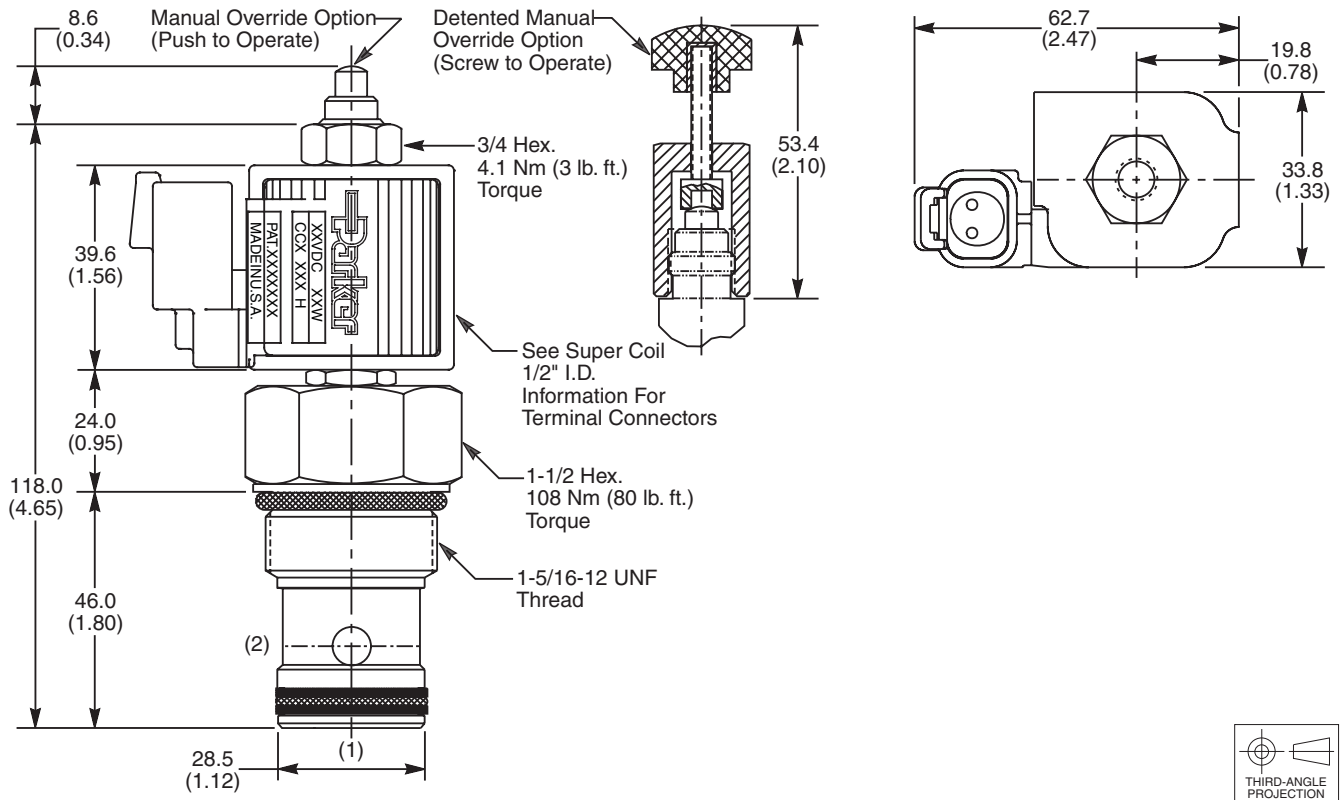

Ordering Information

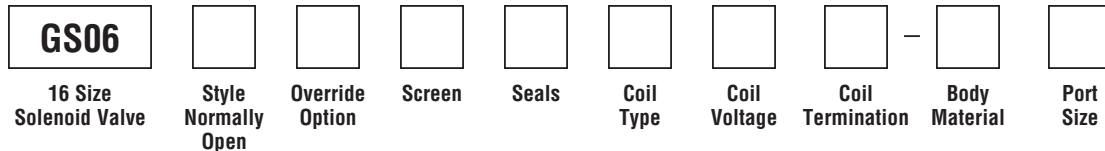

Code	Style
85	Standard ('SS' Coil)
86	High Pressure ('SP' Coil)

Code	Override Options
0	None
1	Manual Override
2	Detented Part No. 900690

Code	Screen
0	None

Code	Seals / Kit No.
N	Nitrile / Buna-N (Std.) (SK30089N-1)
V	Fluorocarbon / (SK30089V-1)

Code	Coil Type
Omit	Without Coil
SS	Super Coil - 14 Watts
SP	Super Coil - 19 Watts

Code	Coil Voltage
Omit	Without Coil
D012	12 VDC
D024	24 VDC
A120	120 VAC, 60/50 Hz
A240	240 VAC, 60/50 Hz*

*22 Watts

Code	Coil Termination
Omit	Without Coil
C	Conduit With Leads
D	DIN Plug Face
A	Amp Jr. Timer*
S	Dual Spade*
L	Dual Lead Wire*
LS	Sealed Lead Wire*
H	Molded Deutsch*

See Super Coil 1/2" I.D.
*DC Only

Code	Body Material
Omit	Steel
A	Aluminum

Code	Port Size	Body Part No.
Omit	Cartridge Only	
16T	SAE-16	(B16-2-*16T)
16B	1" BSPG	(B16-2-16B)†

* Add "A" for aluminum, omit for steel.
† Steel body only.

Technical Information

- CV** Check Valves
- SH** Shuttle Valves
- LM** Load/Motor Controls
- FC** Flow Controls
- PC** Pressure Controls
- LE** Logic Elements
- DC** Directional Controls
- MV** Manual Valves
- SV** Solenoid Valves
- PV** Proportional Valves
- CE** Coils & Electronics
- BC** Bodies & Cavities
- TD** Technical Data

General Description

2-Way Spool Valves. For additional information see Technical Tips on pages SV1-SV6.



Features

- High flow capacity with reduced space requirements
- Standard valve bodies and common cavities
- One-piece encapsulated coil with minimal amperage draw
- Manual overrides, seal variations and other options available
- No dynamic seals
- Variety of coil terminations
- Polyurethane “D”-Ring eliminates need for backup rings
- Nylon inserted jam-nut provides secure holding in high vibration applications
- All external parts zinc plated

Specifications

Rated Flow	C - 15 LPM (4 GPM) N - 11 LPM (3 GPM)	
Maximum Inlet Pressure	250 Bar (3600 PSI)	
Leakage at 150 SSU (32cSt)	120 cc/min. (7.5 in ³ /min.) at 250 Bar (3600 PSI)	
Minimum Operating Voltage	85% of rated voltage at 20°C (72°F).	
Response Time	C	De-Energized 40 ms
	N	40 ms
Cartridge Material	All parts steel. All operating parts hardened steel.	
Operating Temp. Range/Seals	-45°C to +93.3°C (“D”-Ring) (-50°F to +200°F) -31.7°C to +121.1°C (Fluorocarbon) (-25°F to +250°F)	
Fluid Compatibility/Viscosity	Mineral-based or synthetic with lubricating properties at viscosities of 45 to 2000 SSU (6 to 420 cSt)	
Filtration	ISO Code 16/13, SAE Class 4 or better	
Approx. Weight	.11 kg (.25 lbs.)	
Cavity	C08-2 (See BC Section for more details)	
Form Tool	Rougher Finisher	None NFT08-2F

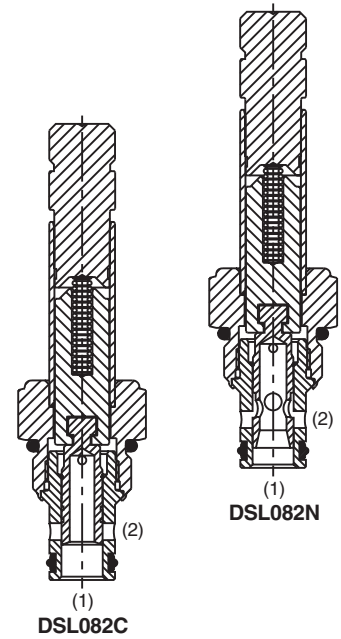
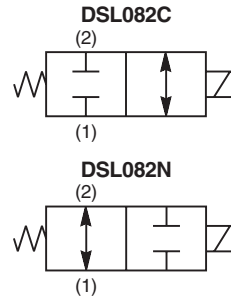

Performance Curves

Pressure Drop vs. Flow (Through cartridge only)

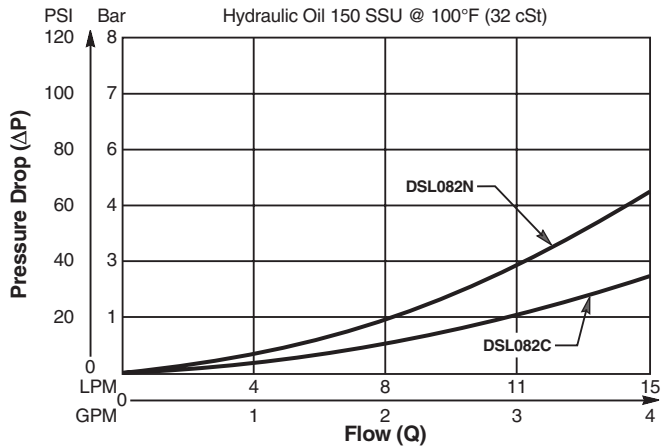

Shift Limit Characteristics (Min. Operating Voltage)

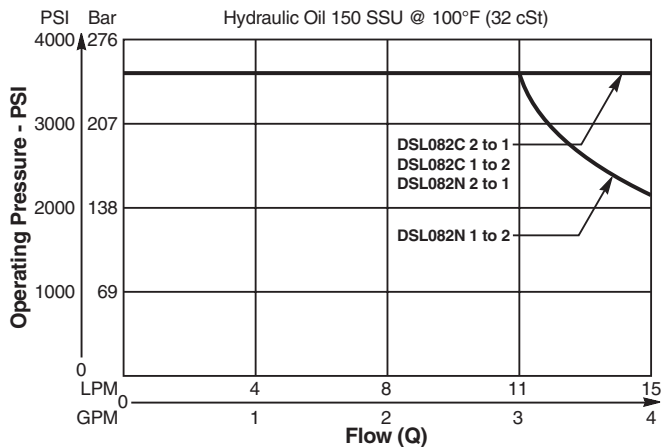

Technical Information

Dimensions Millimeters (Inches)

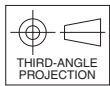
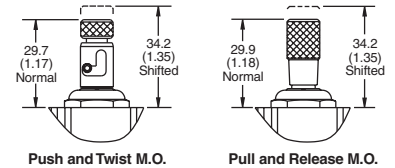
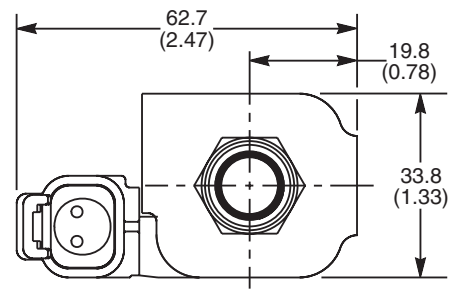
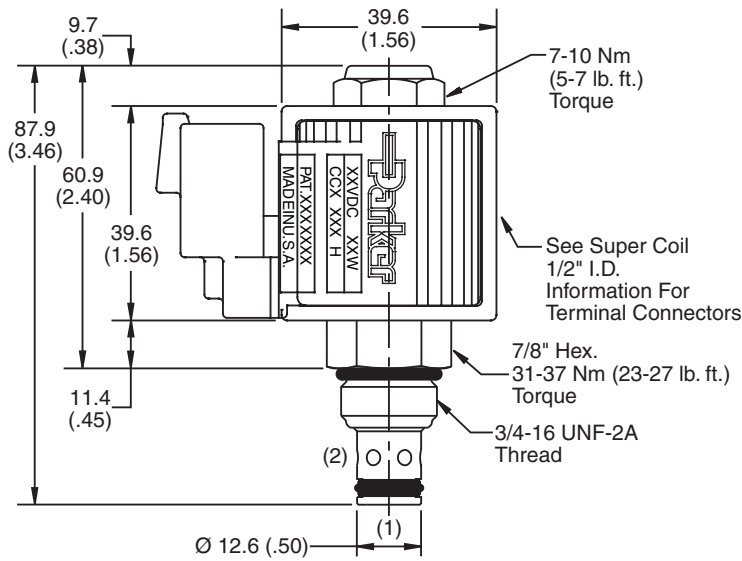

Ordering Information

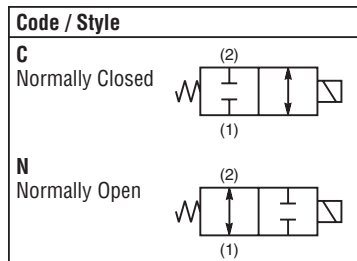
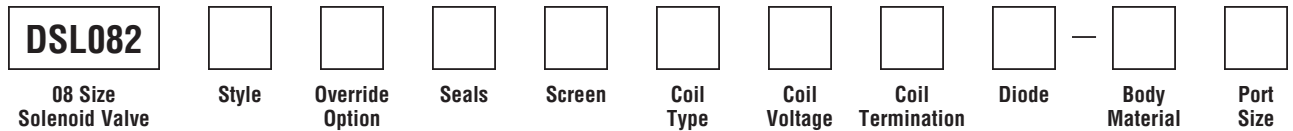

Code	Seals / Kit No.
Omit	"D"-Ring / (SK08-2)
N	Nitrile / (SK08-2N)
V	Fluorocarbon / (SK08-2V)

Code	Coil Voltage
Omit	Without Coil
D012	12 VDC
D024	24 VDC
A120	120/110 VAC, 60/50 Hz
A240	240/220 VAC, 60/50 Hz

Code	Diode
Omit	None
R	Diode

Code	Screen
Omit	None
S	Screen

Code	Body Material
Omit	Steel
A	Aluminum

Code	Override Options
Omit	None
P	Pull & Release
T	Push & Twist

Code	Coil Type
Omit	Without Coil
SP*	Super Coil - 19 Watts

SP*	Coil Termination
Omit	Without Coil
C	Conduit With Leads
D	DIN Plug Face
A	Amp Jr. Timert†
S	Dual Spade†
L	Dual Lead Wire†
LS	Sealed Lead Wire†
H	Molded Deutsch†

Code	Port Size	Body Part No.
Omit	Cartridge Only	
4P	1/4" NPTF	(B08-2-*4P)
6P	3/8" NPTF	(B08-2-*6P)
4T	SAE-4	(B08-2-*4T)
6T	SAE-6	(B08-2-*6T)
6B	3/8" BSPG	(B08-2-*6B)

* Add "A" for aluminum, omit for steel.

*Recommended
†DC Only

- CV** Check Valves
- SH** Shuttle Valves
- LM** Load/Motor Controls
- FC** Flow Controls
- PC** Pressure Controls
- LE** Logic Elements
- DC** Directional Controls
- MV** Manual Valves
- SV** Solenoid Valves
- PV** Proportional Valves
- CE** Coils & Electronics
- BC** Bodies & Cavities
- TD** Technical Data

Technical Information

- CV** Check Valves
- SH** Shuttle Valves
- LM** Load/Motor Controls
- FC** Flow Controls
- PC** Pressure Controls
- LE** Logic Elements
- DC** Directional Controls
- MV** Manual Valves
- SV** Solenoid Valves
- PV** Proportional Valves
- CE** Coils & Electronics
- BC** Bodies & Cavities
- TD** Technical Data

General Description

2-Way Spool Valves. For additional information see Technical Tips on pages SV1-SV6.



Features

- High flow capacity with reduced space requirements
- Standard valve bodies and common cavities
- One-piece encapsulated coil with minimal amperage draw
- Manual overrides, seal variations and other options available
- No dynamic seals
- Variety of coil terminations
- Polyurethane "D"-Ring eliminates need for backup rings
- Nylon inserted jam-nut provides secure holding in high vibration applications
- All external parts zinc plated

Specifications

Rated Flow	C - 15.0 LPM (4 GPM) N - 8.4 LPM (2.8 GPM)	
Maximum Inlet Pressure	350 Bar (5000 PSI)	
Leakage at 150 SSU (32 cSt)	160 cc/min. (10 in ³ /min.) at 350 Bar (5000 PSI)	
Minimum Operating Voltage	85% of rated voltage at 20°C (72°F).	
Response Time	C	De-Energized 40 ms
	N	De-Energized 40 ms
Cartridge Material	All parts steel. All operating parts hardened steel.	
Operating Temp. Range/Seals	-45°C to +93.3°C ("D"-Ring) (-50°F to +200°F) -31.7°C to +121.1°C (Fluorocarbon) (-25°F to +250°F)	
Fluid Compatibility/Viscosity	Mineral-based or synthetic with lubricating properties at viscosities of 45 to 2000 SSU (6 to 420 cSt)	
Filtration	ISO Code 16/13, SAE Class 4 or better	
Approx. Weight	.11 kg (.25 lbs.)	
Cavity	C08-2 (See BC Section for more details)	
Form Tool	Rougher Finisher	None NFT08-2F

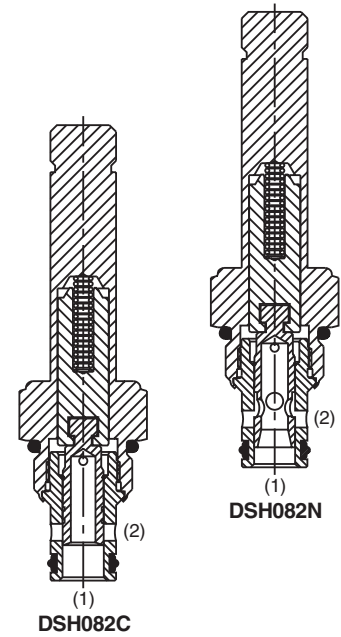
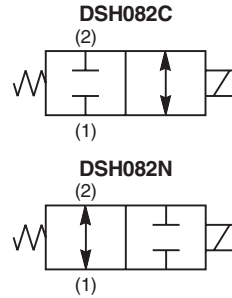

Performance Curves

Pressure Drop vs. Flow (Through cartridge only)

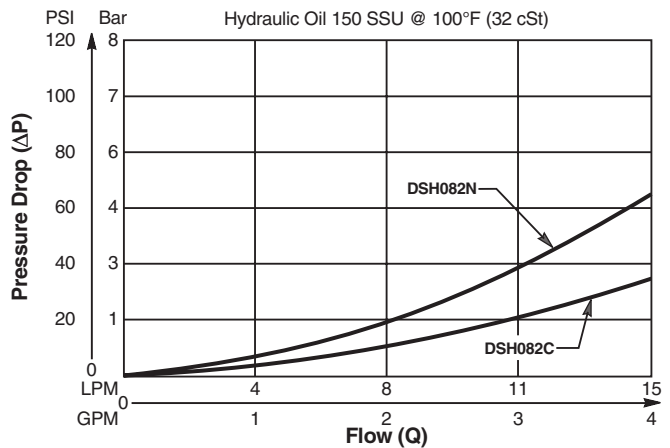

Shift Limit Characteristics (Min. Operating Voltage)

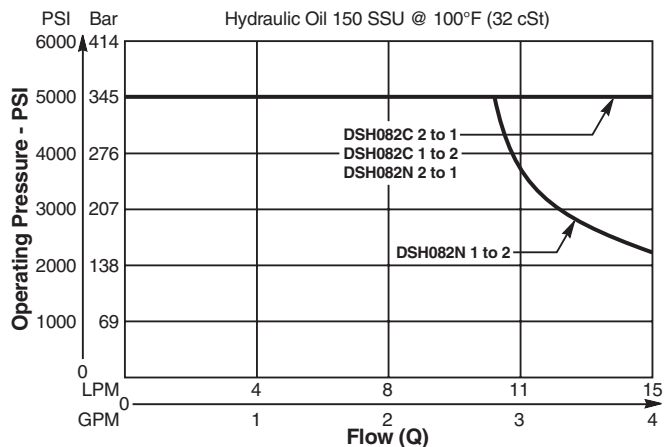

Dimensions Millimeters (Inches)

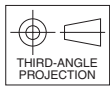
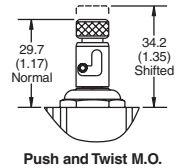
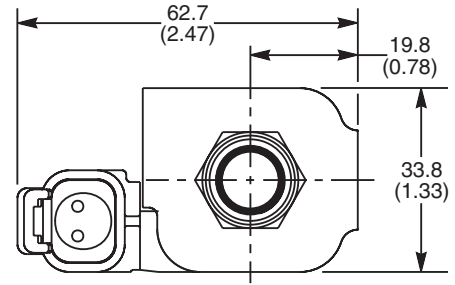
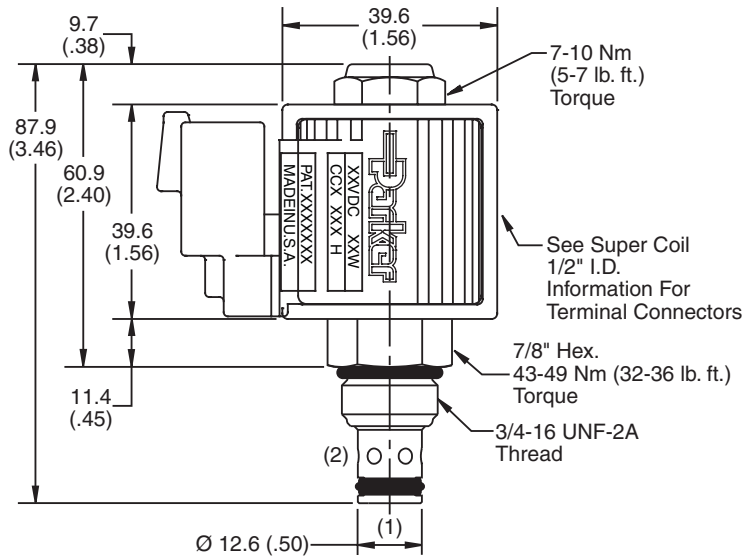

Ordering Information

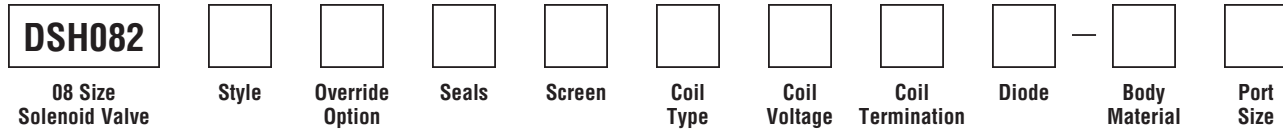

Code / Style	Diagram
C Normally Closed	
N Normally Open	

Code	Seals / Kit. No.
Omit	"D"-Ring / (SK08-2)
N	Nitrile / (SK08-2N)
V	Fluorocarbon / (SK08-2V)

Code	Coil Voltage
Omit	Without Coil
D012	12 VDC
D024	24 VDC
A120	120/110 VAC, 60/50 Hz
A240	240/220 VAC, 60/50 Hz

Code	Diode
Omit	None
R	Diode

Code	Screen
Omit	None
S	Screen

Code	Body Material
Omit	Steel
A	Aluminum

Code	Override Options
Omit	None
T	Push & Twist* (N.C. & N.O.)

Code	Coil Type
Omit	Without Coil
SP*	Super Coil - 19 Watts

SP*	Coil Termination
Omit	Without Coil
C	Conduit With Leads
D	DIN Plug Face
A	Amp Jr. Timert†
S	Dual Spade†
L	Dual Lead Wire†
LS	Sealed Lead Wire†
H	Molded Deutsch†

Code	Port Size	Body Part No.
Omit	Cartridge Only	
4P	1/4" NPTF	(B08-2-*4P)
6P	3/8" NPTF	(B08-2-*6P)
4T	SAE-4	(B08-2-*4T)
6T	SAE-6	(B08-2-*6T)
6B	3/8" BSPG	(B08-2-*6B)

*Requires Super Coil

*Recommended

*Recommended
†DC Only

* Add "A" for aluminum, omit for steel.

Technical Information

- CV** Check Valves
- SH** Shuttle Valves
- LM** Load/Motor Controls
- FC** Flow Controls
- PC** Pressure Controls
- LE** Logic Elements
- DC** Directional Controls
- MV** Manual Valves
- SV** Solenoid Valves
- PV** Proportional Valves
- CE** Coils & Electronics
- BC** Bodies & Cavities
- TD** Technical Data

General Description

2-Way Spool Valves. For additional information see Technical Tips on pages SV1-SV6.



Features

- High flow capacity with reduced space requirements
- Standard valve bodies and common cavities
- One-piece encapsulated coil with minimal amperage draw
- Manual overrides, seal variations and other options available
- No dynamic seals
- Variety of coil terminations
- Polyurethane "D"-Ring
- All external parts zinc plated

Specifications

Rated Flow	C - 30 LPM (8.0 GPM) N - 21 LPM (5.5 GPM)		
Maximum Inlet Pressure	250 Bar (3600 PSI)		
Leakage at 150 SSU (32 cSt)	120 cc/min. (7.5 in ³ /min.)		
Minimum Operating Voltage	85% of rated voltage at 20°C (72°F).		
Response Time	C	Energized	De-Energized
	N	30 ms	20 ms
		50 ms	25 ms
Cartridge Material	All parts steel. All operating parts hardened steel.		
Operating Temp. Range/Seals	-45°C to +93.3°C ("D"-Ring) (-50°F to +200°F) -31.7°C to +121.1°C (Fluorocarbon) (-25°F to +250°F)		
Fluid Compatibility/Viscosity	Mineral-based or synthetic with lubricating properties at viscosities of 45 to 2000 SSU (6 to 420 cSt)		
Filtration	ISO Code 16/13, SAE Class 4 or better		
Approx. Weight	.18 kg (.41 lbs.)		
Cavity	C10-2 (See BC Section for more details)		
Form Tool	Rougher	None	
	Finisher	NFT10-2F	

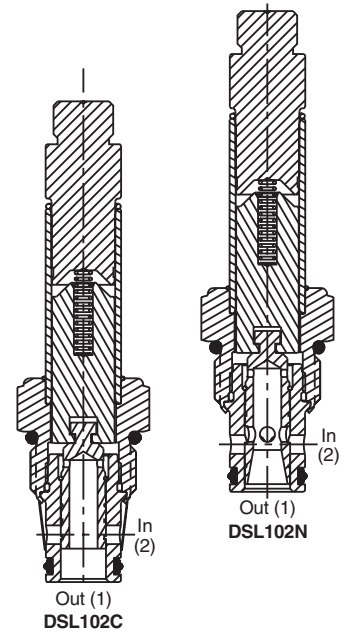
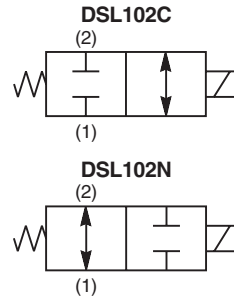

Performance Curves

Pressure Drop vs. Flow (Through cartridge only)

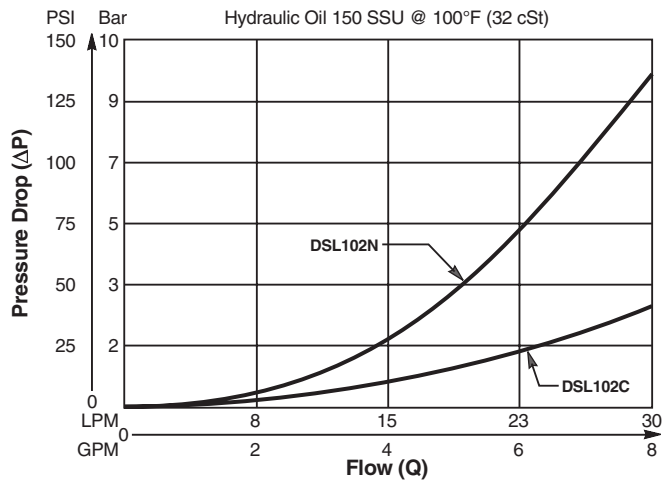

Shift Limit Characteristics (Min. Operating Voltage)

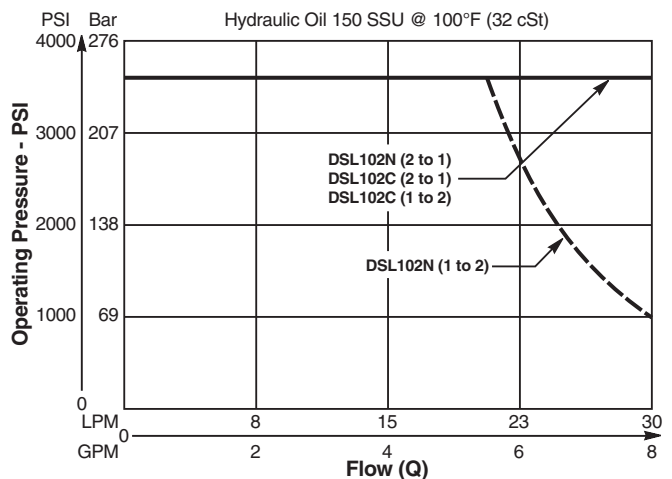

Technical Information

Dimensions Millimeters (Inches)

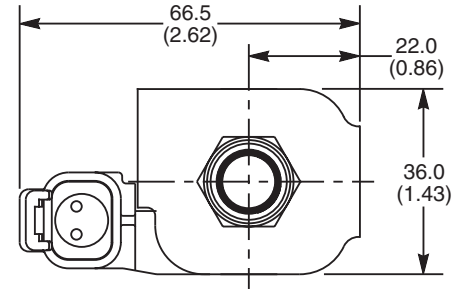
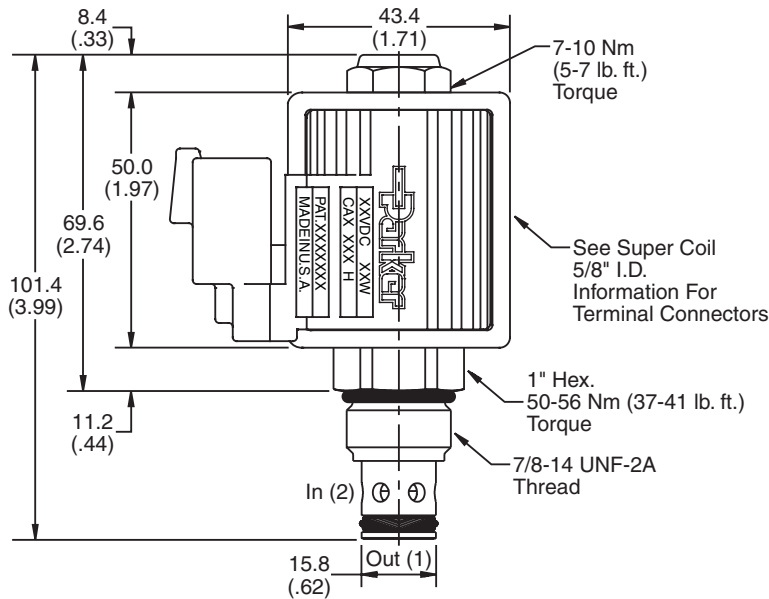

Push and Twist M.O.

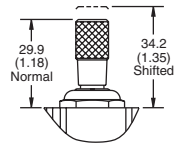

Pull and Release M.O.

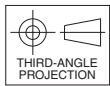

Ordering Information

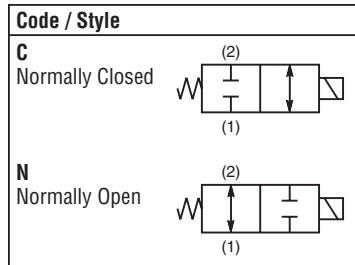
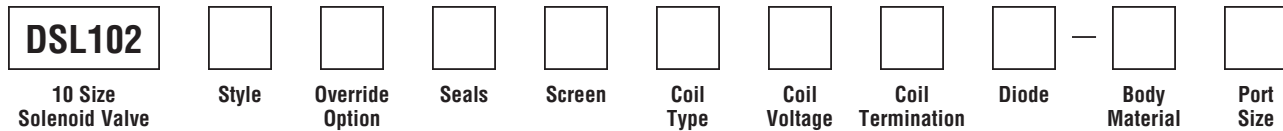

Code	Override Options
Omit	None
P	Pull & Release
T	Push & Twist

Code	Seals / Kit No.
Omit	"D"-Ring / (SK10-2)
N	Nitrile / (SK10-2N)
V	Fluorocarbon / (SK10-2V)

Code	Screen
Omit	None
S	Screen

Code	Coil Type
Omit	Without Coil
SP*	Super Coil - 28 Watts

*Recommended

Code	Coil Voltage
Omit	Without Coil
D012	12 VDC
D024	24 VDC
A120	120/110 VAC, 60/50 Hz
A240	240/220 VAC, 60/50 Hz

SP* Coil	Coil Termination
Omit	Without Coil
C	Conduit With Leads
D	DIN Plug Face
A	Amp Jr. Timert
S	Dual Spade†
L	Dual Lead Wire†
LS	Sealed Lead Wire†
H	Molded Deutsch†

*Recommended
†DC Only

Code	Diode
Omit	None
R	Diode

Code	Body Material
Omit	Steel
A	Aluminum

Code	Port Size	Body Part No.
Omit	Cartridge Only	
4P	1/4" NPTF	(B10-2-*4P)
6P	3/8" NPTF	(B10-2-*6P)
8P	1/2" NPTF	(B10-2-*8P)
6T	SAE-6	(B10-2-*6T)
8T	SAE-8	(B10-2-*8T)
T8T	SAE-8	(B10-2-T8T)†
6B	3/8" BSPG	(B10-2-6B)†

* Add "A" for aluminum. omit for steel.
† Steel body only.

Technical Information

- CV** Check Valves
- SH** Shuttle Valves
- LM** Load/Motor Controls
- FC** Flow Controls
- PC** Pressure Controls
- LE** Logic Elements
- DC** Directional Controls
- MV** Manual Valves
- SV** Solenoid Valves
- PV** Proportional Valves
- CE** Coils & Electronics
- BC** Bodies & Cavities
- TD** Technical Data

General Description

2-Way Spool Valves. For additional information see Technical Tips on pages SV1-SV6.



Features

- High flow capacity with reduced space requirements
- Standard valve bodies and common cavities
- One-piece encapsulated coil with minimal amperage draw
- Manual overrides, seal variations and other options available
- No dynamic seals
- Variety of coil terminations
- Polyurethane "D"-Ring eliminates need for backup rings
- Nylon inserted jam-nut provides secure holding in high vibration applications
- All external parts zinc plated

Specifications

Rated Flow	C - 30 LPM (8.0 GPM) N - 19 LPM (5.0 GPM)	
Maximum Inlet Pressure	350 Bar (5000 PSI)	
Leakage at 150 SSU (32 cSt)	160 cc/min. (10 in ³ /min.)	
Minimum Operating Voltage	85% of rated voltage at 20°C (72°F).	
Response Time	C	De-Energized
	N	Energized
		30 ms
		20 ms
		50 ms
		25 ms
Cartridge Material	All parts steel. All operating parts hardened steel.	
Operating Temp. Range/Seals	-45°C to +93.3°C ("D"-Ring) (-50°F to +200°F) -31.7°C to +121.1°C (Fluorocarbon) (-25°F to +250°F)	
Fluid Compatibility/Viscosity	Mineral-based or synthetic with lubricating properties at viscosities of 45 to 2000 SSU (6 to 420 cSt)	
Filtration	ISO Code 16/13, SAE Class 4 or better	
Approx. Weight	.18 kg (.40 lbs.)	
Cavity	C10-2 (See BC Section for more details)	
Form Tool	Rougher Finisher	None NFT10-2F

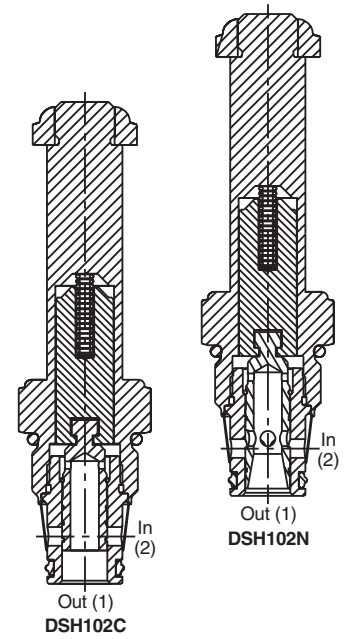
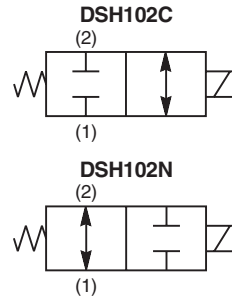

Performance Curves

Pressure Drop vs. Flow (Through cartridge only)

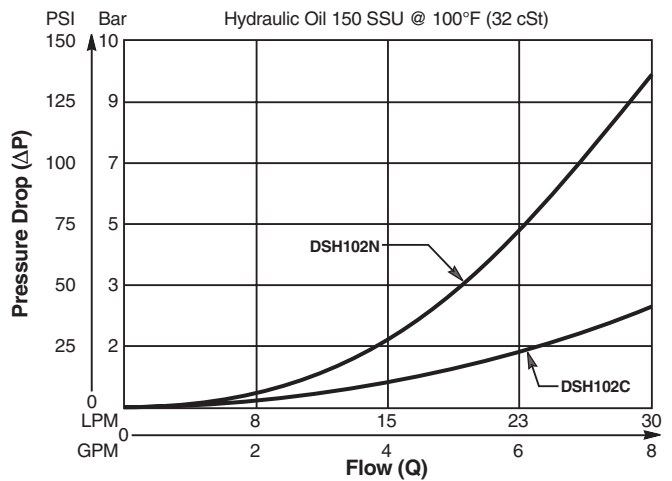

Shift Limit Characteristics (Min. Operating Voltage)

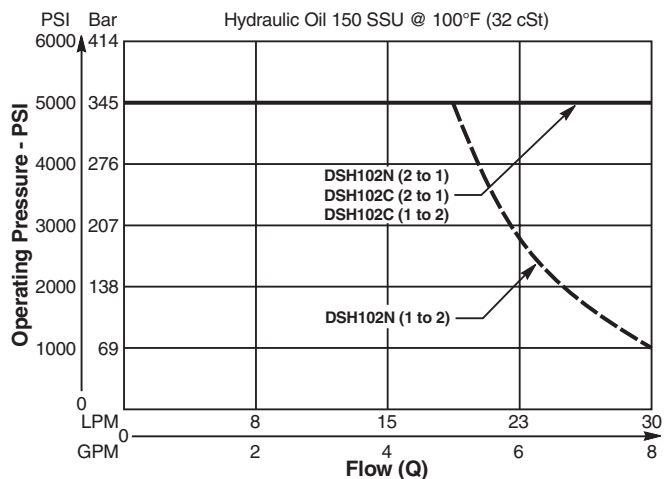

Dimensions Millimeters (Inches)

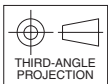
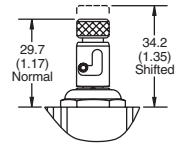
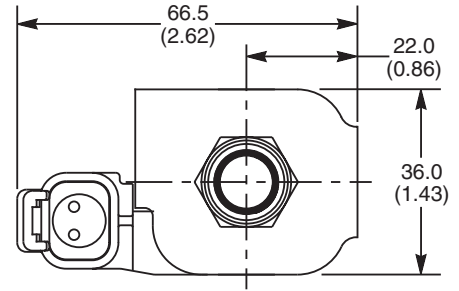
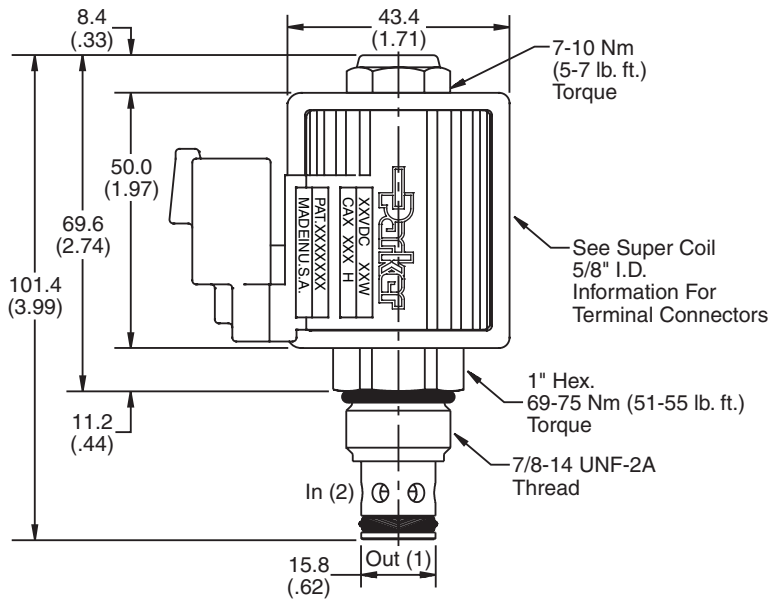

Ordering Information

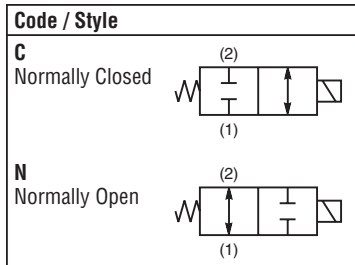
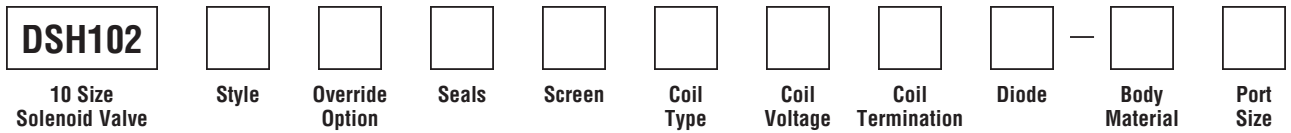

Code	Override Options
Omit	None
T	Push & Twist (N.C. & N.O.)

Code	Seals / Kit No.
Omit	"D"-Ring / (SK10-2)
N	Nitrile / (SK10-2N)
V	Fluorocarbon / (SK10-2V)

Code	Screen
Omit	None
S	Screen

Code	Coil Type
Omit	Without Coil
SP*	Super Coil - 28 Watts

*Recommended

Code	Coil Voltage
Omit	Without Coil
D012	12 VDC
D024	24 VDC
A120	120/110 VAC, 60/50 Hz
A240	240/220 VAC, 60/50 Hz

SP* Coil	Coil Termination
Omit	Without Coil
C	Conduit With Leads
D	DIN Plug Face
A	Amp Jr. Timert
S	Dual Spade†
L	Dual Lead Wire†
LS	Sealed Lead Wire†
H	Molded Deutsch†

*Recommended
†DC Only

Code	Diode
Omit	None
R	Diode

Code	Body Material
Omit	Steel
A	Aluminum

Code	Port Size	Body Part No.
Omit	Cartridge Only	
4P	1/4" NPTF	(B10-2-*4P)
6P	3/8" NPTF	(B10-2-*6P)
8P	1/2" NPTF	(B10-2-*8P)
6T	SAE-6	(B10-2-*6T)
8T	SAE-8	(B10-2-*8T)
T8T	SAE-8	(B10-2-T8T)†
6B	3/8" BSPG	(B10-2-6B)†

* Add "A" for aluminum. omit for steel.
† Steel body only.

Technical Information

- CV** Check Valves
- SH** Shuttle Valves
- LM** Load/Motor Controls
- FC** Flow Controls
- PC** Pressure Controls
- LE** Logic Elements
- DC** Directional Controls
- MV** Manual Valves
- SV** Solenoid Valves
- PV** Proportional Valves
- CE** Coils & Electronics
- BC** Bodies & Cavities
- TD** Technical Data

General Description

2-Way Spool Valves. For additional information see Technical Tips on pages SV1-SV6.

Features

- Low hysteresis
- One-piece encapsulated coil with minimal amperage draw
- Variety of coil terminations and voltages
- Manual override standard (push and release)
- All external parts zinc plated

Specifications

Rated Flow	75 LPM (20 GPM)
Maximum Inlet Pressure	210 Bar (3000 PSI)
Leakage at 150 SSU (32 cSt)	240 cc/min. (15 in ³ /min.)
Minimum Operating Voltage	85% of rated voltage at 20°C (72°F).
Response Time	C - 90 ms N - 100 ms
Cartridge Material	All parts steel. All operating parts hardened steel.
Operating Temp. Range/Seals	-40°C to +93.3°C (Nitrile) (-40°F to +200°F) -31.7°C to +121.1°C (Fluorocarbon) (-25°F to +250°F)
Fluid Compatibility/Viscosity	Mineral-based or synthetic with lubricating properties at viscosities of 45 to 2000 SSU (6 to 420 cSt)
Filtration	ISO Code 16/13, SAE Class 4 or better
Approx. Weight	.59 kg (1.3 lbs.)
Cavity	C16-2 (See BC Section for more details)
Form Tool	Rougher None Finisher NFT16-2F

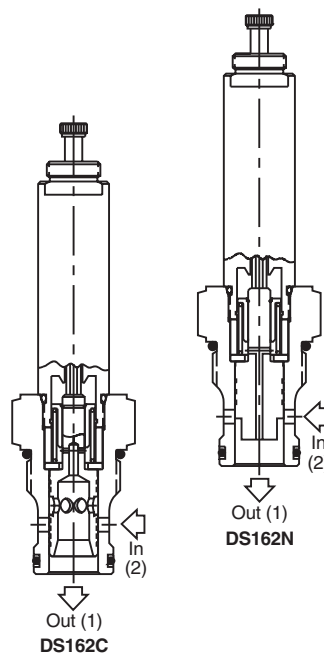
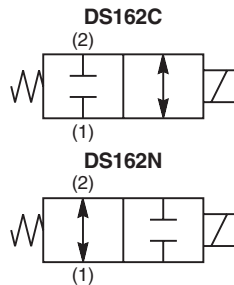
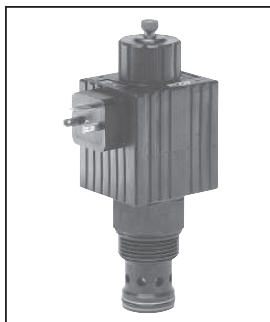

Performance Curves

Pressure Drop vs. Flow (Through cartridge only)

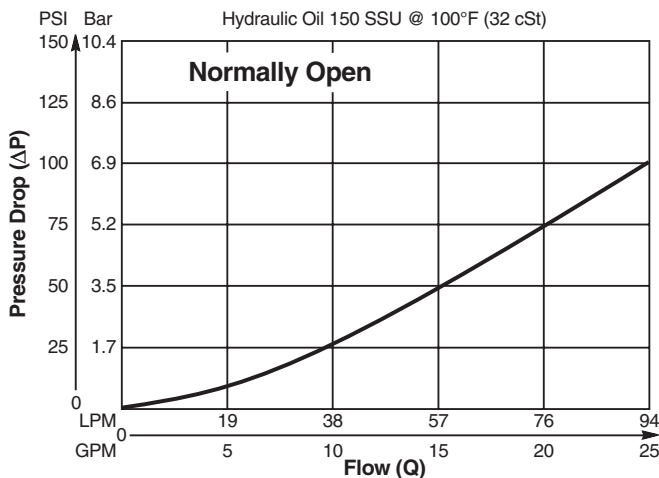
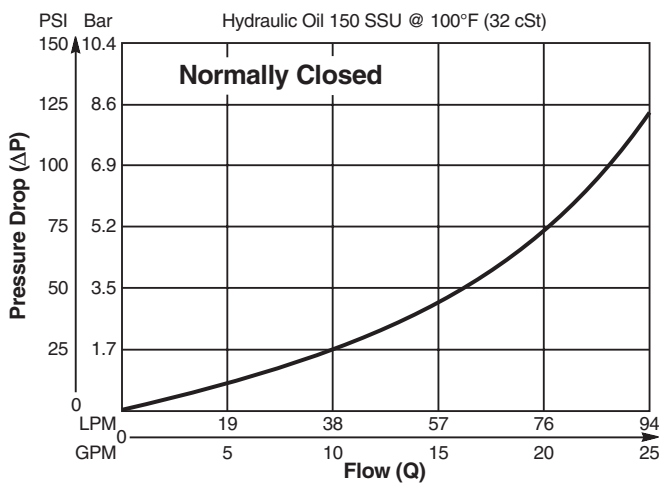

Technical Information

Dimensions Millimeters (Inches)

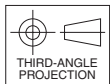
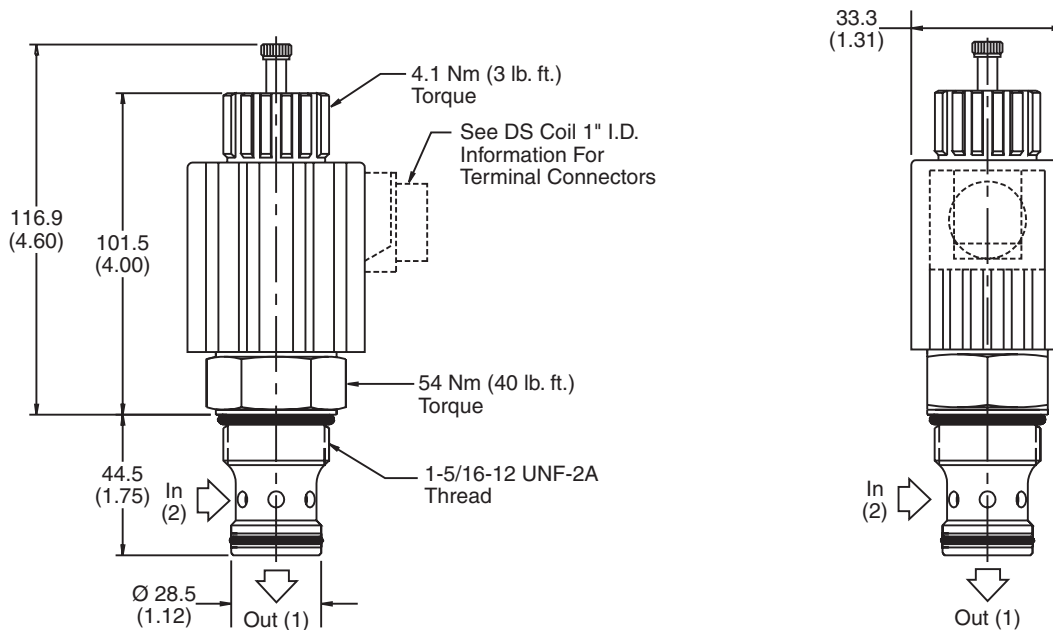

Ordering Information

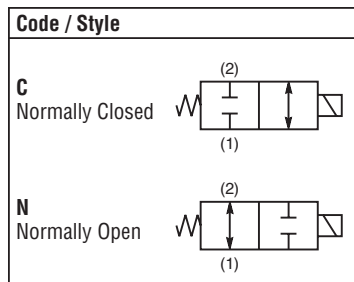
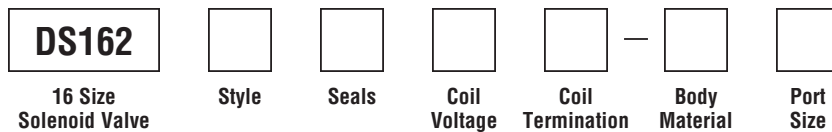

Code	Seals / Kit No.
Omit	Nitrile / (SK16-2)
V	Fluorocarbon / (SK16-2V)

Code	Coil Voltage
Omit	Without Coil
D012	12 VDC
D024	24 VDC
A120	120/110 VAC, 60/50 Hz

Code	Coil Termination
Omit	Without Coil
C	Conduit (AC Only)
D	DIN Plug Face
P	Dual Spade (DC Only)
S	Dual Screw (DC Only)
W	Dual Lead (DC Only)

See DS coil 1" I.D.

Code	Body Material
Omit	Steel
A	Aluminum

Code	Port Size	Body Part No.
Omit	Cartridge Only	
12T	SAE-12	(B16-2-*12T)
16T	SAE-16	(B16-2-*16T)
12B	3/4" BSPG	(B16-2-*12B)
16B	1" BSPG	(B16-2-16B)†

* Add "A" for aluminum, omit for steel.
† Steel body only.

- CV Check Valves
- SH Shuttle Valves
- LM Load/Motor Controls
- FC Flow Controls
- PC Pressure Controls
- LE Logic Elements
- DC Directional Controls
- MV Manual Valves
- SV Solenoid Valves
- PV Proportional Valves
- CE Coils & Electronics
- BC Bodies & Cavities
- TD Technical Data

Technical Information

- CV** Check Valves
- SH** Shuttle Valves
- LM** Load/Motor Controls
- FC** Flow Controls
- PC** Pressure Controls
- LE** Logic Elements
- DC** Directional Controls
- MV** Manual Valves
- SV** Solenoid Valves
- PV** Proportional Valves
- CE** Coils & Electronics
- BC** Bodies & Cavities
- TD** Technical Data

General Description

3-Way Spool Valves. For additional information see Technical Tips on pages SV1-SV6.



Features

- High flow capacity with reduced space requirements
- Standard valve bodies and common cavities
- One piece encapsulated coils with minimal amperage draw
- Manual overrides, seal variations and other options available
- No dynamic seals
- Variety of coil terminations
- Polyurethane "D"-Ring eliminates need for backup rings
- Nylon inserted jam-nut provides secure holding in high vibration applications
- All external parts zinc plated

Specifications

Rated Flow	DSL083A	N.O. 13.2 LPM (3.5 GPM)
		N.C. 8.4 LPM (2.25 GPM)
	DSL083B	Selector 8.4 LPM (2.25 GPM)
		N.C. 15.0 LPM (4.0 GPM)
	DSL083C	Selector 15.0 LPM (4.0 GPM)
		N.O. 15.0 LPM (4.0 GPM)
	DSL083N	N.O. 12.3 LPM (3.25 GPM)
		Selector 15.0 LPM (4.0 GPM)
Maximum Inlet Pressure	250 Bar (3600 PSI)	
Leakage at 150 SSU (32 cSt)	120 cc/min. (7.5 in ³ /min.) at 250 Bar (3600 PSI) DSL083B - 180 cc/min. (11 in ³ /min.) DSL083N - 180 cc/min. (11 in ³ /min.)	
Minimum Operating Voltage	85% of rated voltage at 20°C (72°F).	
Response Time	50 ms	
Cartridge Material	All parts steel. All operating parts hardened steel.	
Operating Temp. Range/Seals	-45°C to +93.3°C ("D"-Ring) (-50°F to +200°F) -31.7°C to +121.1°C (Fluorocarbon) (-25°F to +250°F)	
Fluid Compatibility/Viscosity	Mineral-based or synthetic with lubricating properties at viscosities of 45 to 2000 SSU (6 to 420 cSt)	
Filtration	ISO Code 16/13, SAE Class 4 or better	
Approx. Weight	.13 kg (.28 lbs.)	
Cavity	C08-3 (See BC Section for more details)	
Form Tool	Rougher	NFT08-3R
	Finisher	NFT08-3F

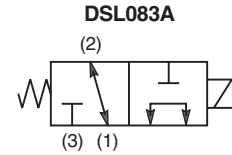

Construction/Symbols

DSL083A

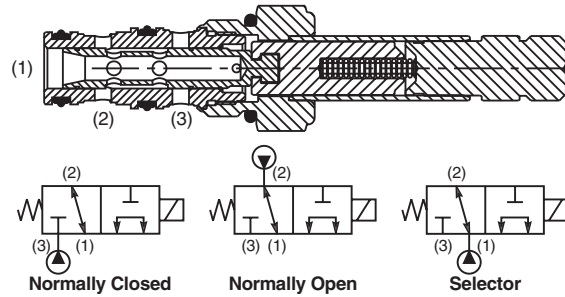

DSL083B

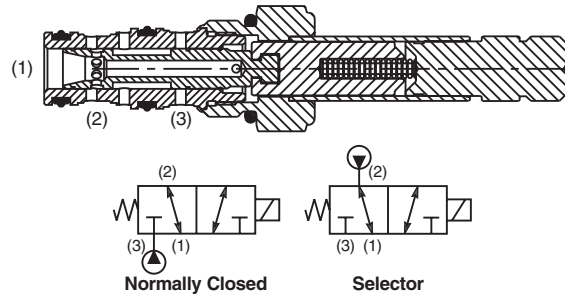

DSL083C

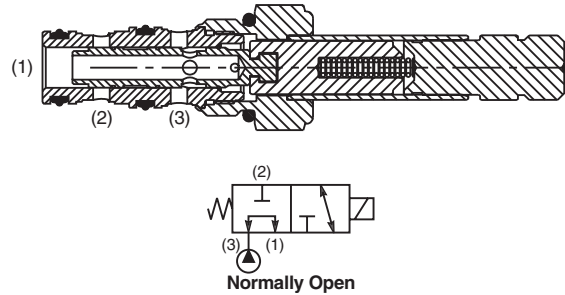

DSL083N

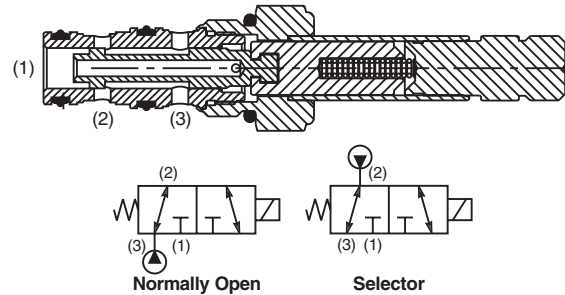

Dimensions Millimeters (Inches)

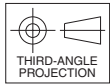
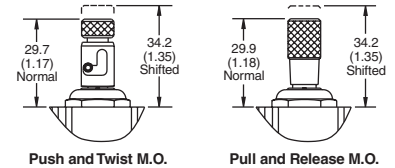
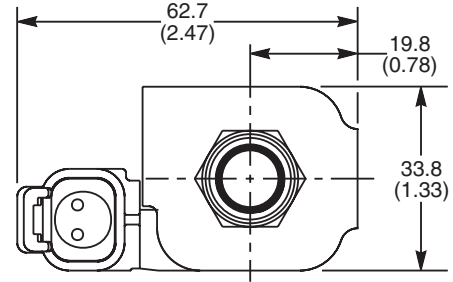
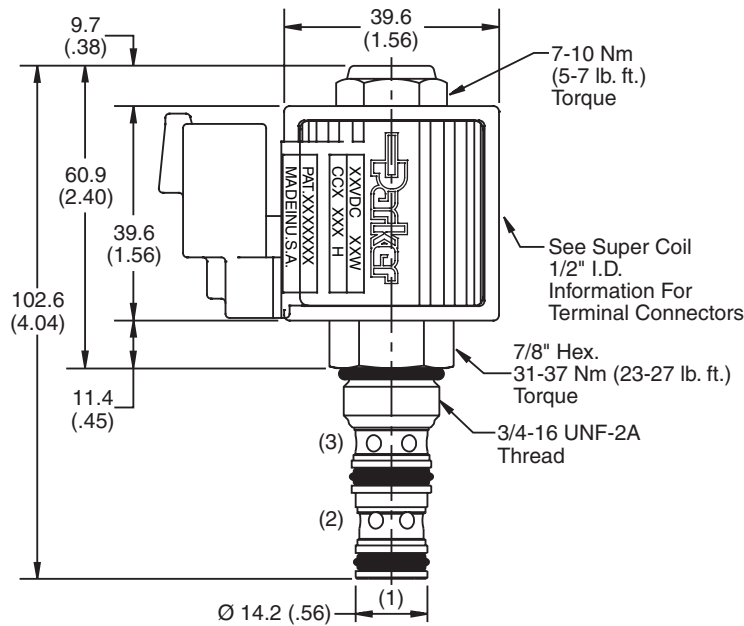

Ordering Information

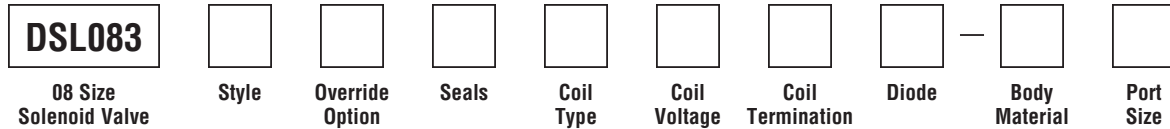

Code	Style
A	
B	
C	
N	

Code	Override Options
Omit	None
P	Pull & Release
T	Push & Twist

Code	Seals / Kit No.
Omit	"D"-Ring / (SK08-3)
N	Nitrile / (SK08-3N)
V	Fluorocarbon / (SK08-3V)

Code	Coil Type
Omit	Without Coil
SP*	Super Coil - 19 Watts

*Recommended

Code	Coil Voltage
Omit	Without Coil
D012	12 VDC
D024	24 VDC
A120	120/110 VAC, 60/50 Hz
A240	240/220 VAC, 60/50 Hz

SP*	Coil Termination
Omit	Without Coil
C	Conduit With Leads
D	DIN Plug Face
A	Amp Jr. Timert†
S	Dual Spade†
L	Dual Lead Wire†
LS	Sealed Lead Wire†
H	Molded Deutsch†

*Recommended
†DC Only

Code	Diode
Omit	None
R	Diode

Code	Body Material
Omit	Steel
A	Aluminum

Code	Port Size	Body Part No.
Omit	Cartridge Only	
4P	1/4" NPTF	(B08-3-*4P)
4T	SAE-4	(B08-3-*4T)
6T	SAE-6	(B08-3-*6T)
6B	3/8" BSPG	(B08-3-*6B)

* Add "A" for aluminum, omit for steel.

- CV
- Check Valves
- SH
- Shuttle Valves
- LM
- Load/Motor Controls
- FC
- Flow Controls
- PC
- Pressure Controls
- LE
- Logic Elements
- DC
- Directional Controls
- MV
- Manual Valves
- SV
- Solenoid Valves
- PV
- Proportional Valves
- CE
- Coils & Electronics
- BC
- Bodies & Cavities
- TD
- Technical Data

- CV** Check Valves
- SH** Shuttle Valves
- LM** Load/Motor Controls
- FC** Flow Controls
- PC** Pressure Controls
- LE** Logic Elements
- DC** Directional Controls
- MV** Manual Valves
- SV** Solenoid Valves
- PV** Proportional Valves
- CE** Coils & Electronics
- BC** Bodies & Cavities
- TD** Technical Data

Pressure Drop vs. Flow (Through cartridge only)

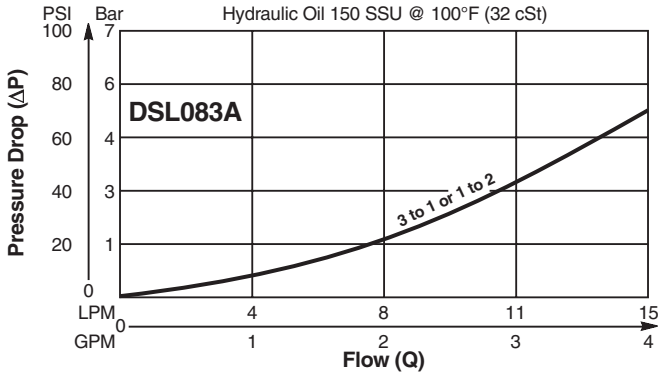

Shift Limit Characteristics (Min. Operating Voltage)

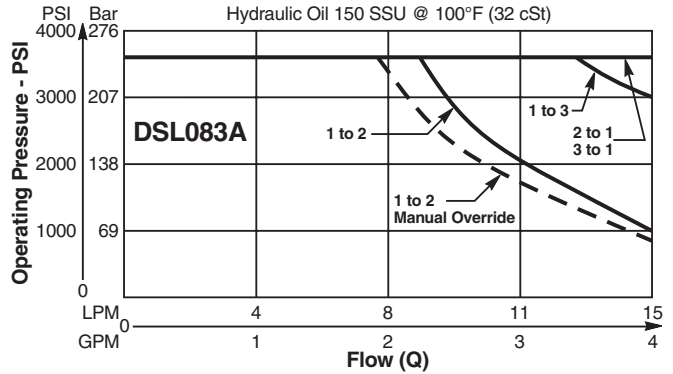

Pressure Drop vs. Flow (Through cartridge only)

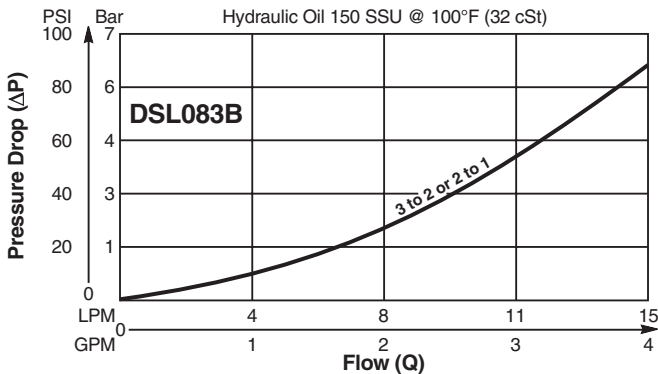

Shift Limit Characteristics (Min. Operating Voltage)

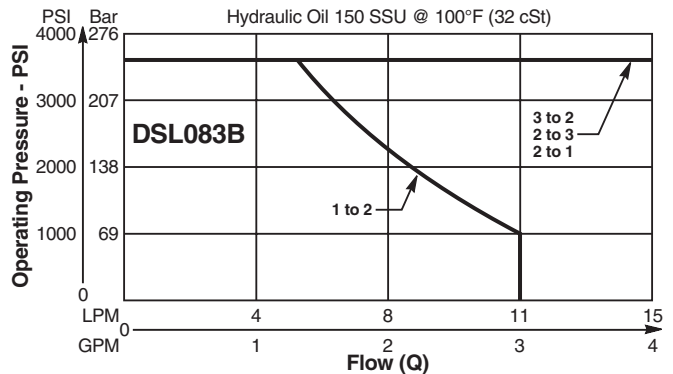

Pressure Drop vs. Flow (Through cartridge only)

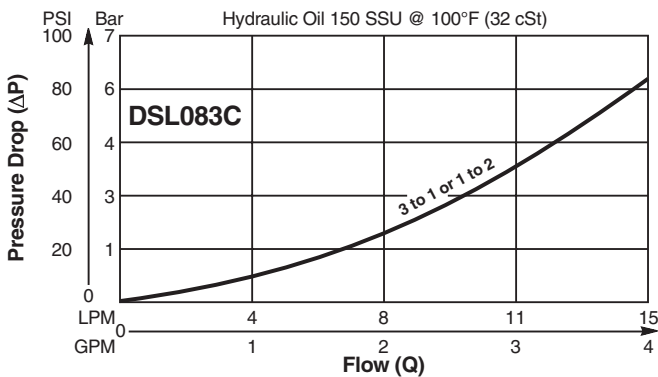

Shift Limit Characteristics (Min. Operating Voltage)

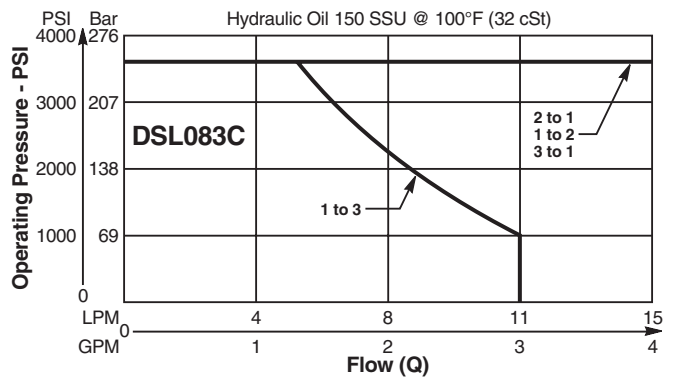

Pressure Drop vs. Flow (Through cartridge only)

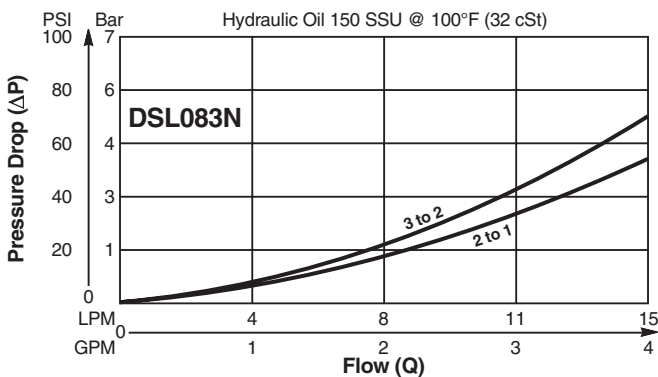

Shift Limit Characteristics (Min. Operating Voltage)

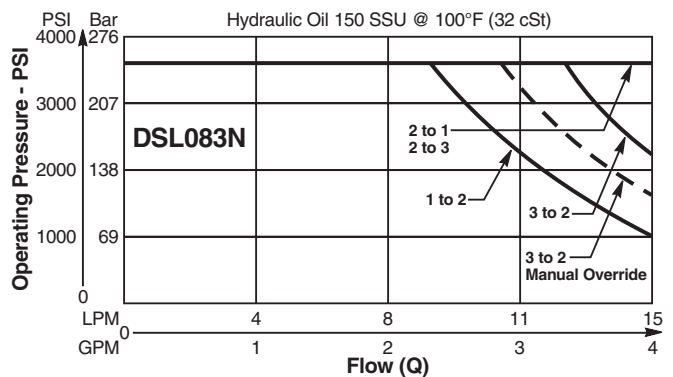

Technical Information

General Description

3-Way Spool Valves. For additional information see Technical Tips on pages SV1-SV6.



Features

- High flow capacity with reduced space requirements
- Standard valve bodies and common cavities
- One piece encapsulated coils with minimal amperage draw
- Manual overrides, seal variations and other options available
- No dynamic seals
- Variety of coil terminations
- Polyurethane "D"-Ring eliminates need for backup rings
- Nylon inserted jam-nut provides secure holding in high vibration applications
- All external parts zinc plated

Specifications

Rated Flow	DSH083A	N.O.	11.3 LPM (3.0 GPM)
		N.C.	7.5 LPM (2.0 GPM)
		Selector	7.5 LPM (2.0 GPM)
	DSH083B	N.C.	15.0 LPM (4.0 GPM)
		Selector	15.0 LPM (4.0 GPM)
	DSH083C	N.O.	15.0 LPM (4.0 GPM)
Maximum Inlet Pressure	350 Bar (5000 PSI)		
	Leakage at 150 SSU (32 cSt)	160 cc/min. (10 in ³ /min.) at 350 Bar (5000 PSI)	
		DSH083B - 250 cc/min. (15 in ³ /min.)	
DSH083N - 250 cc/min. (15 in ³ /min.)			
Minimum Operating Voltage	85% of rated voltage at 20°C (72°F).		
Response Time	50 ms		
Cartridge Material	All parts steel. All operating parts hardened steel.		
Operating Temp. Range/Seals	-45°C to +93.3°C ("D"-Ring) (-50°F to +200°F) -31.7°C to +121.1°C (Fluorocarbon) (-25°F to +250°F)		
Fluid Compatibility/Viscosity	Mineral-based or synthetic with lubricating properties at viscosities of 45 to 2000 SSU (6 to 420 cSt)		
Filtration	ISO Code 16/13, SAE Class 4 or better		
Approx. Weight	.13 kg (.28 lbs.)		
Cavity	C08-3 (See BC Section for more details)		
Form Tool	Rougher	NFT08-3R	
	Finisher	NFT08-3F	

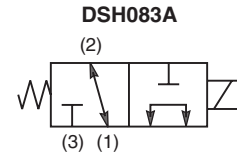

Construction/Symbols

DSH083A

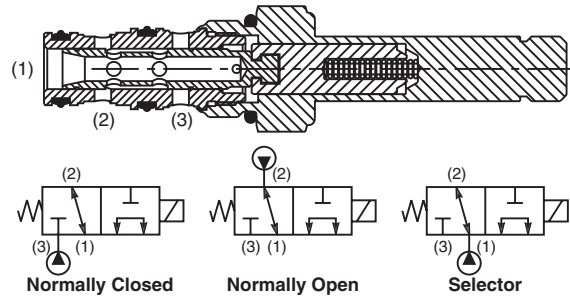

DSH083B

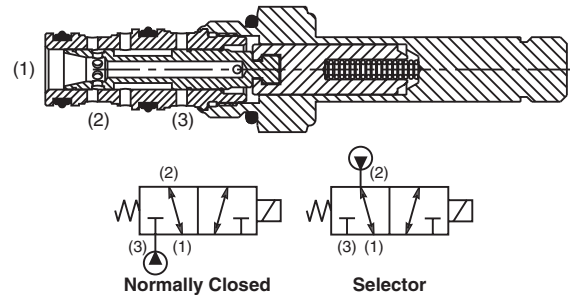

DSH083C

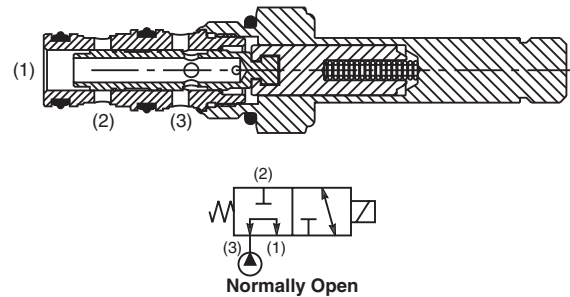

DSH083N

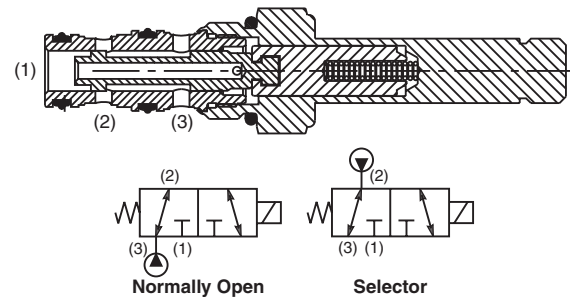

- CV** Check Valves
- SH** Shuttle Valves
- LM** Load/Motor Controls
- FC** Flow Controls
- PC** Pressure Controls
- LE** Logic Elements
- DC** Directional Controls
- MV** Manual Valves
- SV** Solenoid Valves
- PV** Proportional Valves
- CE** Coils & Electronics
- BC** Bodies & Cavities
- TD** Technical Data

Technical Information

Dimensions Millimeters (Inches)

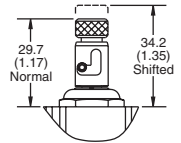
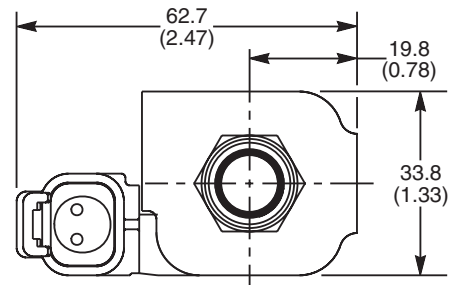
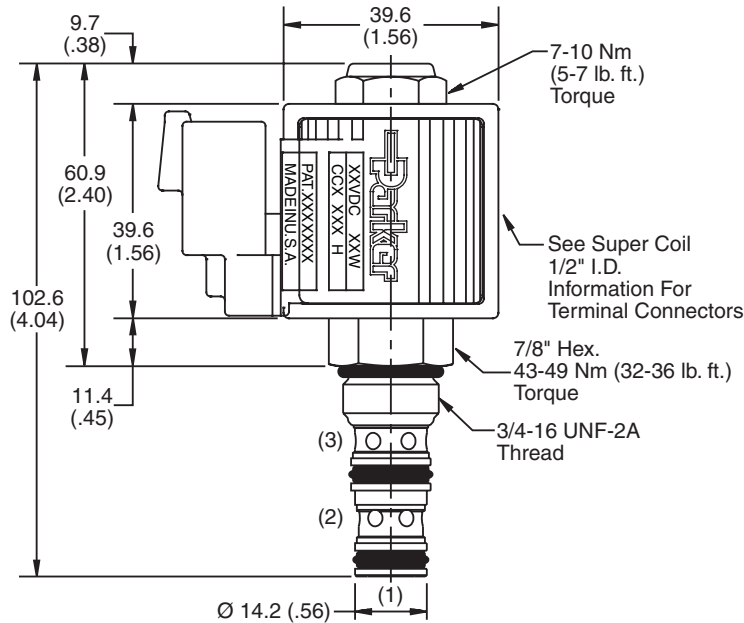

Push and Twist M.O.

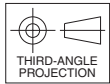

Ordering Information

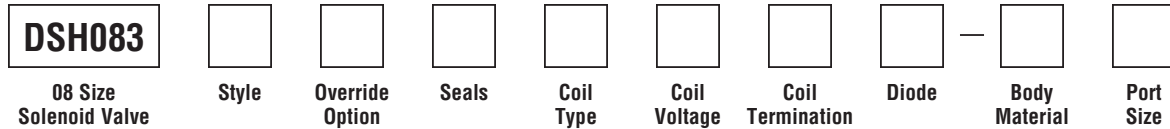

Code	Style
A	
B	
C	
N	

Code	Override Options
Omit	None
T	Push & Twist* (N.C. & N.O.)

Code	Seals / Kit No.
Omit	"D"-Ring / (SK08-3)
N	Nitrile / (SK08-3N)
V	Fluorocarbon / (SK08-3V)

Code	Coil Type
Omit	Without Coil
SP*	Super Coil - 19 Watts

Code	Coil Voltage
Omit	Without Coil
D012	12 VDC
D024	24 VDC
A120	120/110 VAC, 60/50 Hz
A240	240/220 VAC, 60/50 Hz

SP*	Coil Termination
Omit	Without Coil
C	Conduit With Leads
D	DIN Plug Face
A	Amp Jr. Timert†
S	Dual Spade†
L	Dual Lead Wire†
LS	Sealed Lead Wire†
H	Molded Deutsch†

Code	Diode
Omit	None
R	Diode

Code	Body Material
Omit	Steel
A	Aluminum

Code	Port Size	Body Part No.
Omit	Cartridge Only	
4P	1/4" NPTF	(B08-3-*4P)
4T	SAE-4	(B08-3-*4T)
6T	SAE-6	(B08-3-*6T)
6B	3/8" BSPG	(B08-3-*6B)

* Add "A" for aluminum, omit for steel.

*Recommended
†DC Only

Pressure Drop vs. Flow (Through cartridge only)

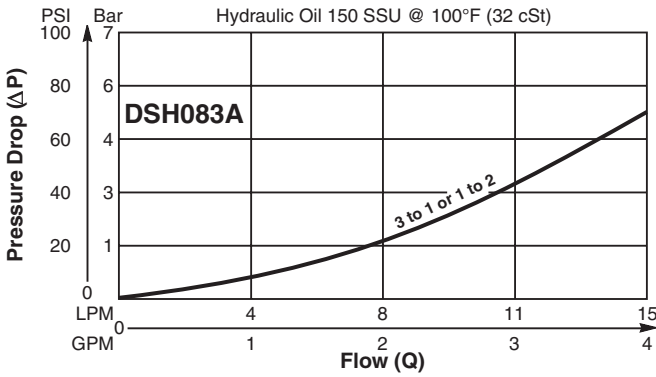

Shift Limit Characteristics (Min. Operating Voltage)

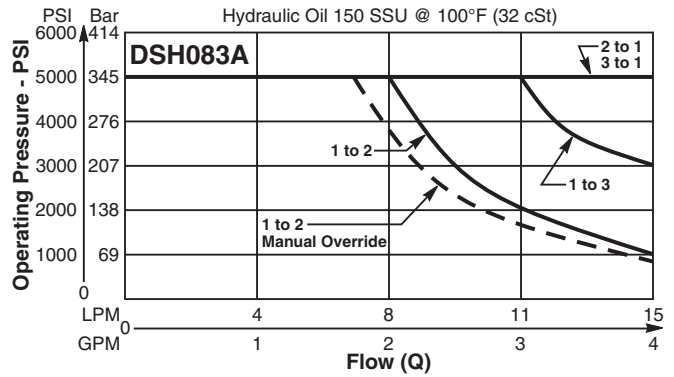

Pressure Drop vs. Flow (Through cartridge only)

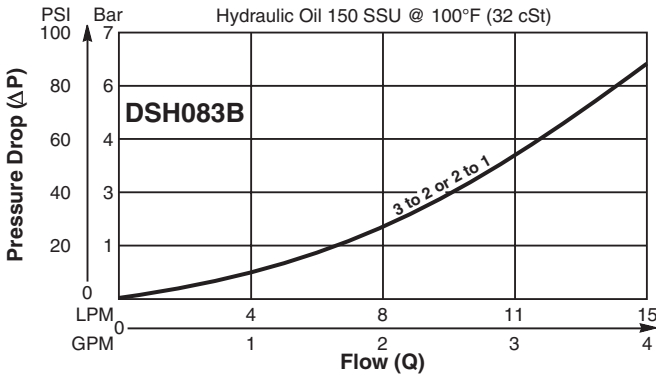

Shift Limit Characteristics (Min. Operating Voltage)

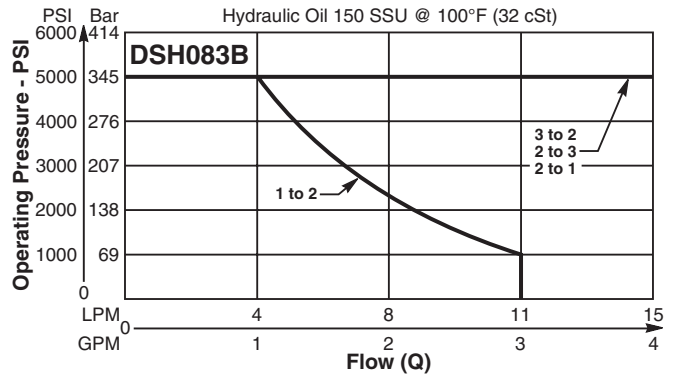

Pressure Drop vs. Flow (Through cartridge only)

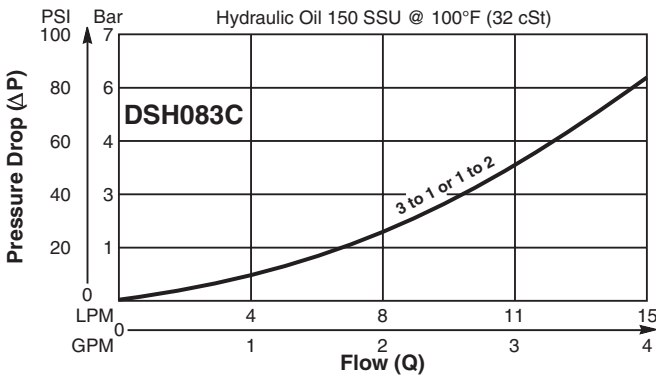

Shift Limit Characteristics (Min. Operating Voltage)

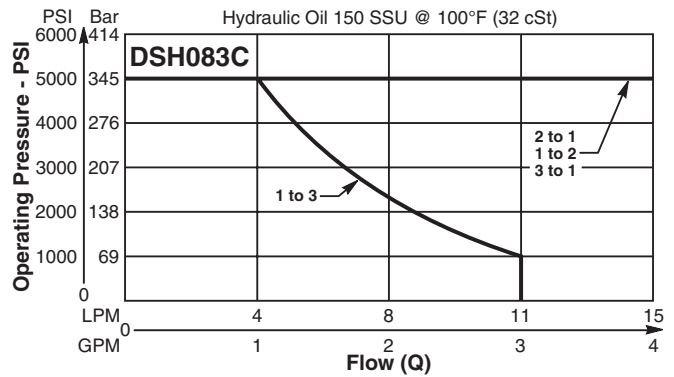

Pressure Drop vs. Flow (Through cartridge only)

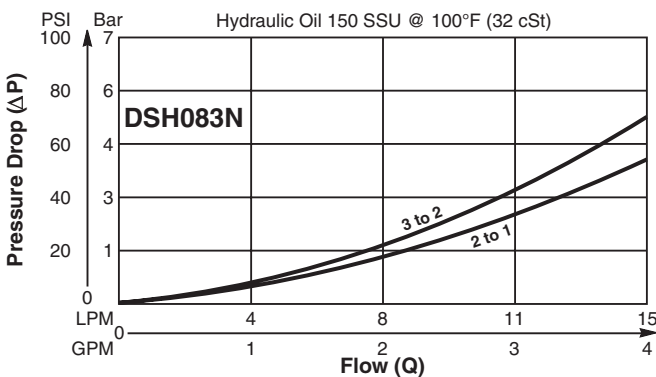

Shift Limit Characteristics (Min. Operating Voltage)

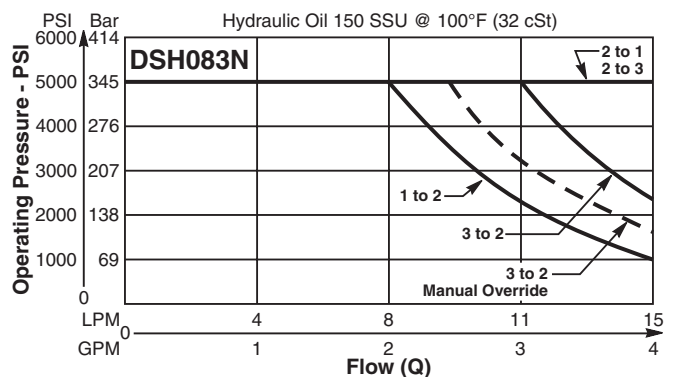

- CV**
- Check Valves
- SH**
- Shuttle Valves
- LM**
- Load/Motor Controls
- FC**
- Flow Controls
- PC**
- Pressure Controls
- LE**
- Logic Elements
- DC**
- Directional Controls
- MV**
- Manual Valves
- SV**
- Solenoid Valves
- PV**
- Proportional Valves
- CE**
- Coils & Electronics
- BC**
- Bodies & Cavities
- TD**
- Technical Data

Technical Information

- CV** Check Valves
- SH** Shuttle Valves
- LM** Load/Motor Controls
- FC** Flow Controls
- PC** Pressure Controls
- LE** Logic Elements
- DC** Directional Controls
- MV** Manual Valves
- SV** Solenoid Valves
- PV** Proportional Valves
- CE** Coils & Electronics
- BC** Bodies & Cavities
- TD** Technical Data

General Description

3-Way Spool Valves. For additional information see Technical Tips on pages SV1-SV6.



Features

- High flow capacity with reduced space requirements
- Standard valve bodies and common cavities
- One-piece encapsulated coil with minimal amperage draw
- Manual overrides, seal variations and other options available
- No dynamic seals
- Variety of coil terminations
- Polyurethane "D"-Ring
- All external parts zinc plated

Specifications

Rated Flow	DSL103A	N.O.	22.7 LPM (6.0 GPM)	
		N.C.	17.0 LPM (4.5 GPM)	
		Selector	17.0 LPM (4.5 GPM)	
	DSL103B	N.C.	30.2 LPM (8.0 GPM)	
		Selector	30.2 LPM (8.0 GPM)	
	DSL103C	N.O.	30.2 LPM (8.0 GPM)	
	DSL103N	N.O.	18.8 LPM (5.0 GPM)	
		N.C.	18.8 LPM (5.0 GPM)	
		Selector	30.2 LPM (8.0 GPM)	
	Maximum Inlet Pressure	250 Bar (3600 PSI)		
	Leakage at 150 SSU (32 cSt)	120 cc/min. (7.5 in ³ /min.) DSL103B - 180 cc/min. (11 in ³ /min.) DSL103N - 180 cc/min. (11 in ³ /min.)		
	Minimum Operating Voltage	85% of rated voltage at 20°C (72°F).		
Response Time	50 ms to 100 ms			
Cartridge Material	All parts steel. All operating parts hardened steel.			
Operating Temp. Range/Seals	-45°C to +93.3°C ("D"-Ring) (-50°F to +200°F) -31.7°C to +121.1°C (Fluorocarbon) (-25°F to +250°F)			
Fluid Compatibility/Viscosity	Mineral-based or synthetic with lubricating properties at viscosities of 45 to 2000 SSU (6 to 420 cSt)			
Filtration	ISO Code 16/13, SAE Class 4 or better			
Approx. Weight	.19 kg (.42 lbs.)			
Cavity	C10-3 (See BC Section for more details)			
Form Tool	Rougher	NFT10-3R		
	Finisher	NFT10-3F		

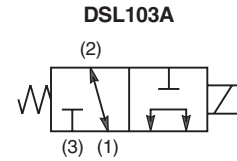

Construction/Symbols

DSL103A

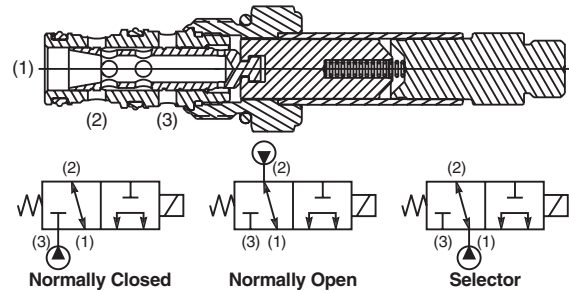

DSL103B

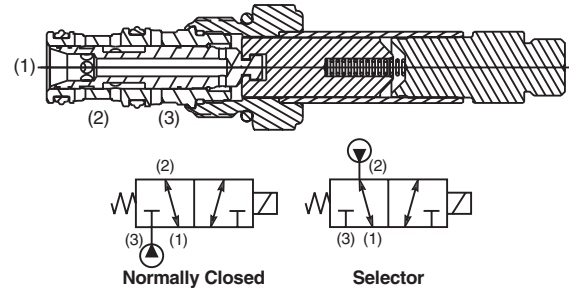

DSL103C

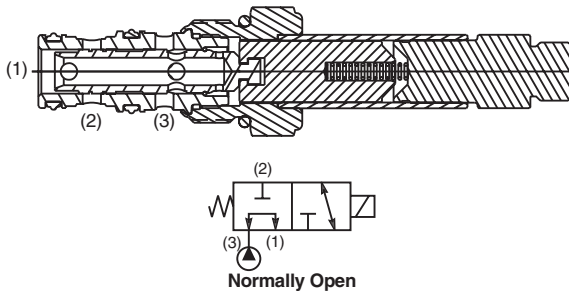

DSL103N

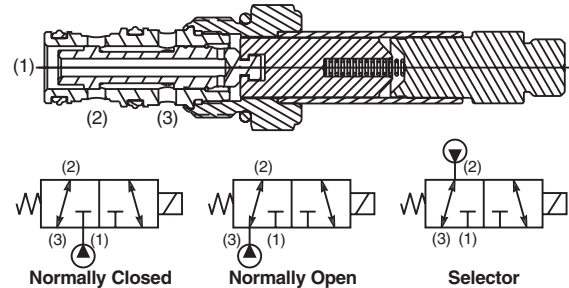

Dimensions Millimeters (Inches)

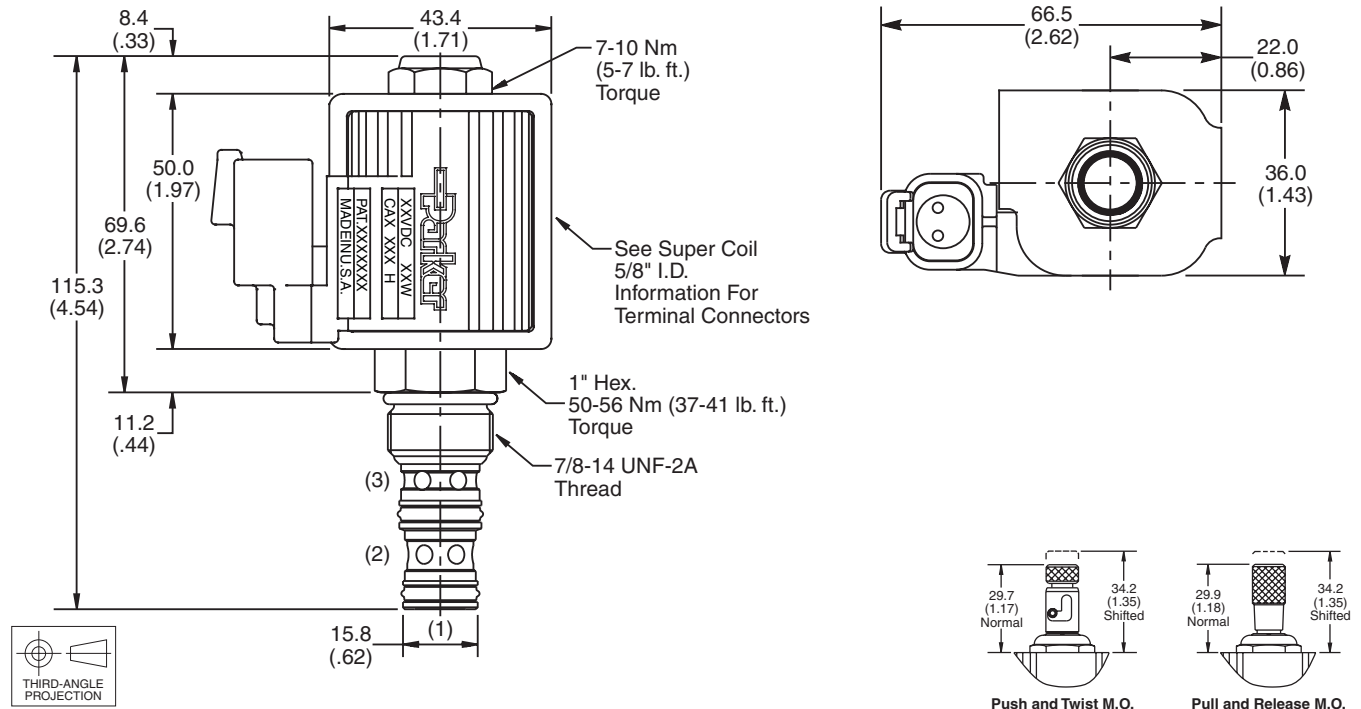

Ordering Information

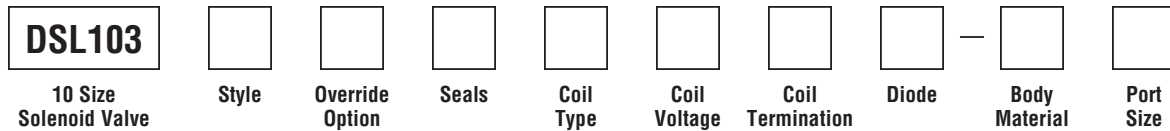

Code	Style
A	
B	
C	
N	

Code	Override Options
Omit	None
P	Pull & Release
T	Push & Twist

Code	Seals / Kit No.
Omit	"D"-Ring / (SK10-3)
N	Nitrile / (SK10-3N)
V	Fluorocarbon / (SK10-3V)

Code	Coil Type
Omit	Without Coil
SP*	Super Coil - 28 Watts

*Recommended

Code	Coil Voltage
Omit	Without Coil
D012	12 VDC
D024	24 VDC
A120	120/110 VAC, 60/50 Hz
A240	240/220 VAC, 60/50 Hz

SP*	Coil Termination
Omit	Without Coil
C	Conduit With Leads
D	DIN Plug Face
A	Amp Jr. Timert†
S	Dual Spade†
L	Dual Lead Wire†
LS	Sealed Lead Wire†
H	Molded Deutsch†

*Recommended
†DC Only

Code	Diode
Omit	None
R	Diode

Code	Body Material
Omit	Steel
A	Aluminum

Code	Port Size	Body Part No.
Omit	Cartridge Only	
4P	1/4" NPTF	(B10-3-*4P)
6P	3/8" NPTF	(B10-3-*6P)
8P	1/2" NPTF	(B10-3-*8P)
6T	SAE-6	(B10-3-*6T)
8T	SAE-8	(B10-3-*8T)
6B	3/8" BSPG	(B10-3-6B)†
8B	1/2" BSPG	(B10-3-*8B)

* Add "A" for aluminum, omit for steel.
† Steel bodies only.

- CV** Check Valves
- SH** Shuttle Valves
- LM** Load/Motor Controls
- FC** Flow Controls
- PC** Pressure Controls
- LE** Logic Elements
- DC** Directional Controls
- MV** Manual Valves
- SV** Solenoid Valves
- PV** Proportional Valves
- CE** Coils & Electronics
- BC** Bodies & Cavities
- TD** Technical Data

Pressure Drop vs. Flow (Through cartridge only)

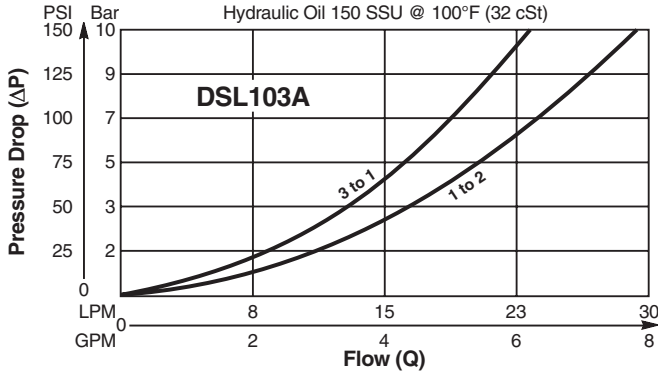

Shift Limit Characteristics (Min. Operating Voltage)

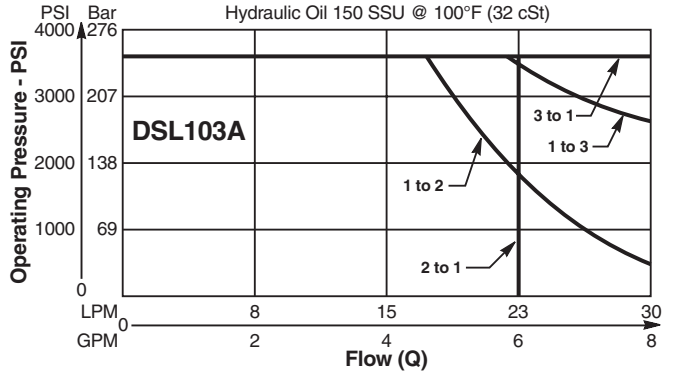

Pressure Drop vs. Flow (Through cartridge only)

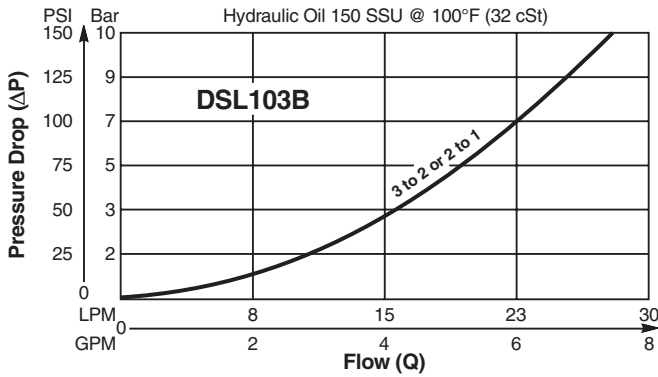

Shift Limit Characteristics (Min. Operating Voltage)

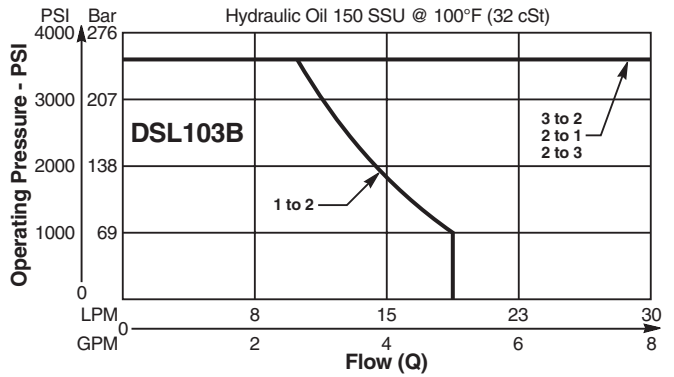

Pressure Drop vs. Flow (Through cartridge only)

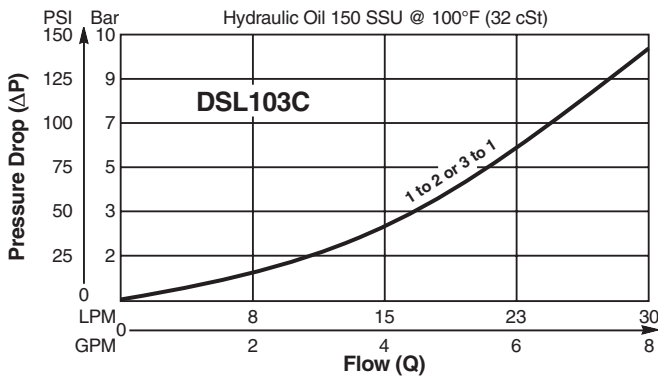

Shift Limit Characteristics (Min. Operating Voltage)

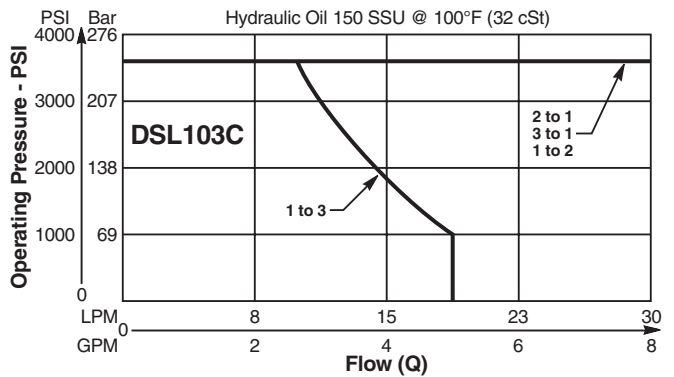

Pressure Drop vs. Flow (Through cartridge only)

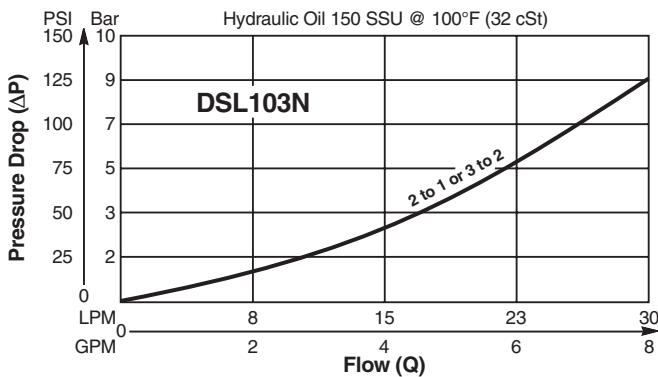

Shift Limit Characteristics (Min. Operating Voltage)

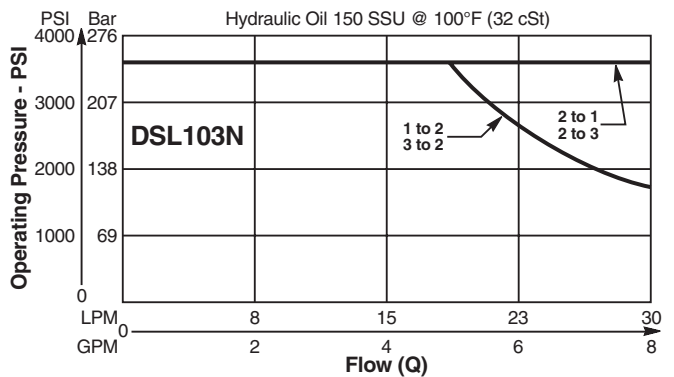

Technical Information

General Description

3-Way Spool Valves. For additional information see Technical Tips on pages SV1-SV6.



Features

- High flow capacity with reduced space requirements
- Standard valve bodies and common cavities
- One-piece encapsulated coil with minimal amperage draw
- Manual overrides, seal variations and other options available
- No dynamic seals
- Variety of coil terminations
- Polyurethane "D"-Ring eliminates need for backup rings
- Nylon inserted jam-nut provides secure holding in high vibration applications
- All external parts zinc plated

Specifications

Rated Flow	DSH103A	N.O. 17.0 LPM (4.5 GPM)
		N.C. 15.0 LPM (4.0 GPM)
	DSH103B	N.O. 30.0 LPM (8.0 GPM)
		Selector 30.0 LPM (8.0 GPM)
	DSH103C	N.O. 30.0 LPM (8.0 GPM)
		N.O. 15.0 LPM (4.0 GPM)
	DSH103N	N.C. 15.0 LPM (4.0 GPM)
		Selector 30.0 LPM (8.0 GPM)
Maximum Inlet Pressure	350 Bar (5000 PSI)	
Leakage at 150 SSU (32 cSt)	160 cc/min. (10 in ³ /min.) DSH103B - 250 cc/min. (15 in ³ /min.) DSH103N - 250 cc/min. (15 in ³ /min.)	
Minimum Operating Voltage	85% of rated voltage at 20°C (72°F).	
Response Time	50 ms to 100 ms	
Cartridge Material	All parts steel. All operating parts hardened steel.	
Operating Temp. Range/Seals	-45°C to +93.3°C ("D"-Ring) (-50°F to +200°F) -31.7°C to +121.1°C (Fluorocarbon) (-25°F to +250°F)	
Fluid Compatibility/Viscosity	Mineral-based or synthetic with lubricating properties at viscosities of 45 to 2000 SSU (6 to 420 cSt)	
Filtration	ISO Code 16/13, SAE Class 4 or better	
Approx. Weight	.19 kg (.42 lbs.)	
Cavity	C10-3 (See BC Section for more details)	
Form Tool	Rougher NFT10-3R	Finisher NFT10-3F

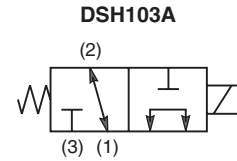

Construction/Symbols

DSH103A

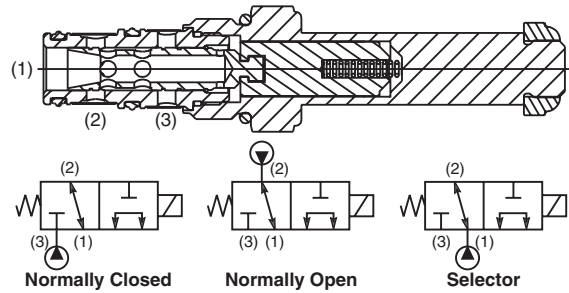

DSH103B

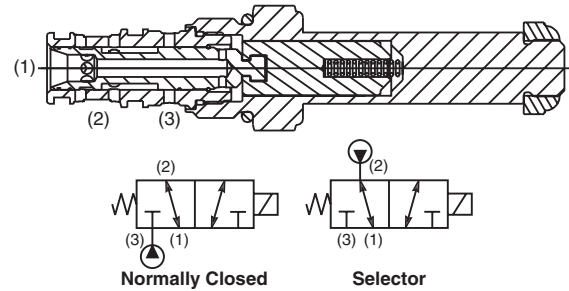

DSH103C

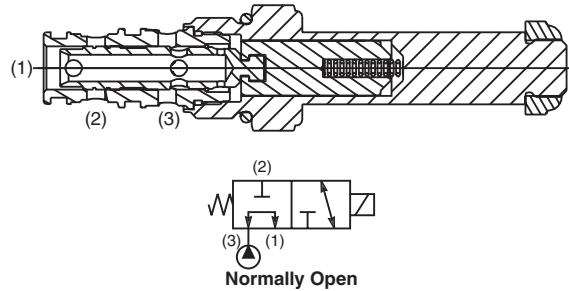

DSH103N

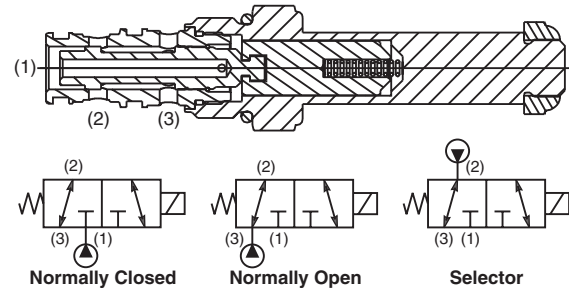

CV

Check Valves

SH

Shuttle Valves

LM

Load/Motor Controls

FC

Flow Controls

PC

Pressure Controls

LE

Logic Elements

DC

Directional Controls

MV

Manual Valves

SV

Solenoid Valves

PV

Proportional Valves

CE

Coils & Electronics

BC

Bodies & Cavities

TD

Technical Data

Spool Type, 3-Way Valve Series DSH103

Dimensions Millimeters (Inches)

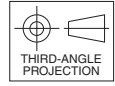
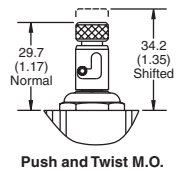
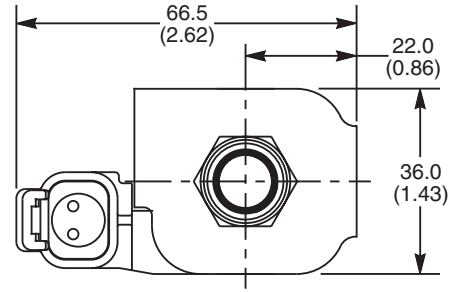
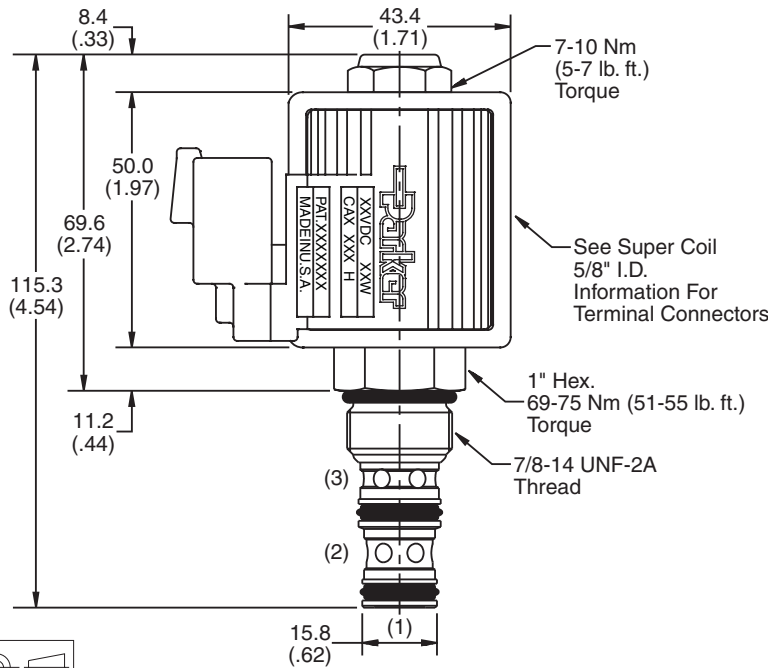

Ordering Information

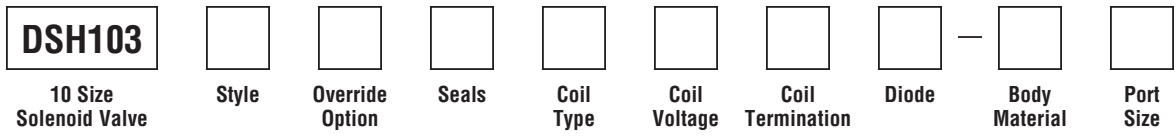

Code	Style
A	
B	
C	
N	

Code	Override Options
Omit	None
T	Push & Twist (N.C. & N.O.)

Code	Seals / Kit No.
Omit	"D"-Ring / (SK10-3)
N	Nitrile / (SK10-3N)
V	Fluorocarbon / (SK10-3V)

Code	Coil Type
Omit	Without Coil
SP*	Super Coil - 28 Watts

*Recommended

Code	Coil Voltage
Omit	Without Coil
D012	12 VDC
D024	24 VDC
A120	120/110 VAC, 60/50 Hz
A240	240/220 VAC, 60/50 Hz

SP*	Coil	Coil Termination
Omit	Without Coil	
C	Conduit With Leads	
D	DIN Plug Face	
A	Amp Jr. Timert	
S	Dual Spade†	
L	Dual Lead Wire†	
LS	Sealed Lead Wire†	
H	Molded Deutsch†	

*Recommended
†DC Only

Code	Diode
Omit	None
R	Diode

Code	Body Material
Omit	Steel
A	Aluminum

Code	Port Size	Body Part No.
Omit	Cartridge Only	
4P	1/4" NPTF	(B10-3-*4P)
6P	3/8" NPTF	(B10-3-*6P)
8P	1/2" NPTF	(B10-3-*8P)
6T	SAE-6	(B10-3-*6T)
8T	SAE-8	(B10-3-*8T)
6B	3/8" BSPG	(B10-3-6B)†
8B	1/2" BSPG	(B10-3-*8B)

* Add "A" for aluminum, omit for steel.
† Steel bodies only.

Pressure Drop vs. Flow (Through cartridge only)

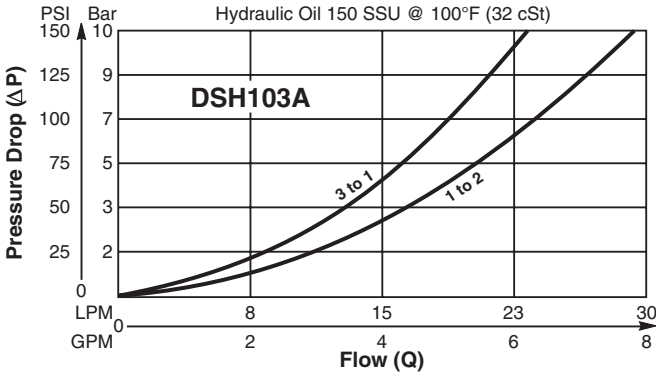

Shift Limit Characteristics (Min. Operating Voltage)

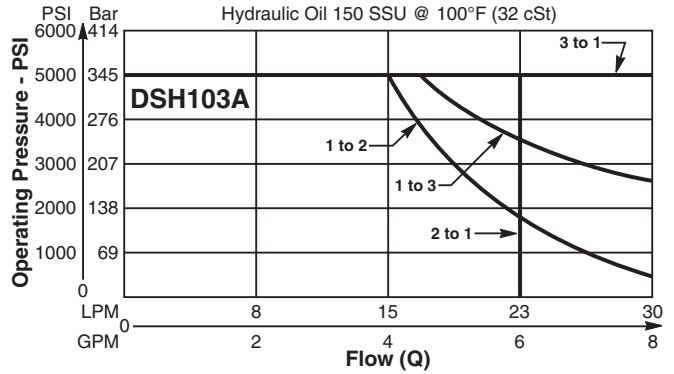

Pressure Drop vs. Flow (Through cartridge only)

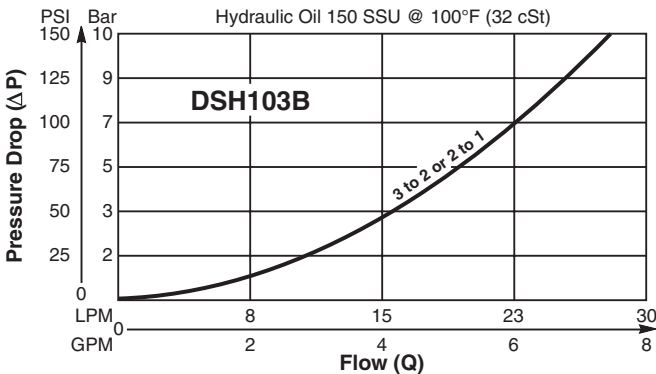

Shift Limit Characteristics (Min. Operating Voltage)

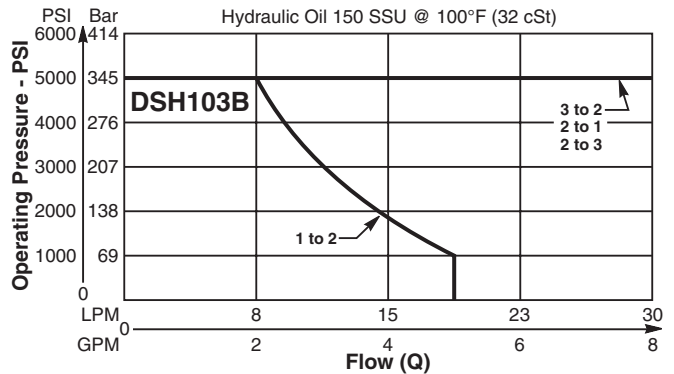

Pressure Drop vs. Flow (Through cartridge only)

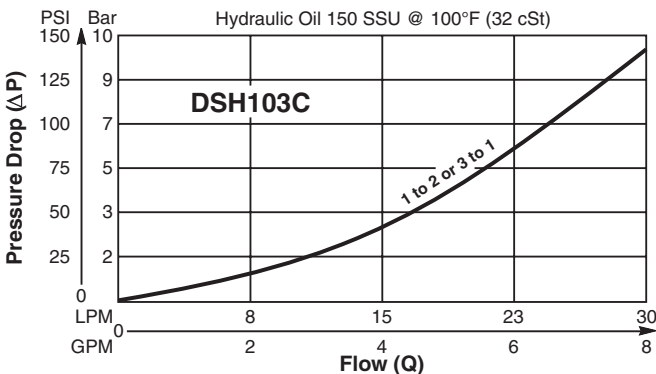

Shift Limit Characteristics (Min. Operating Voltage)

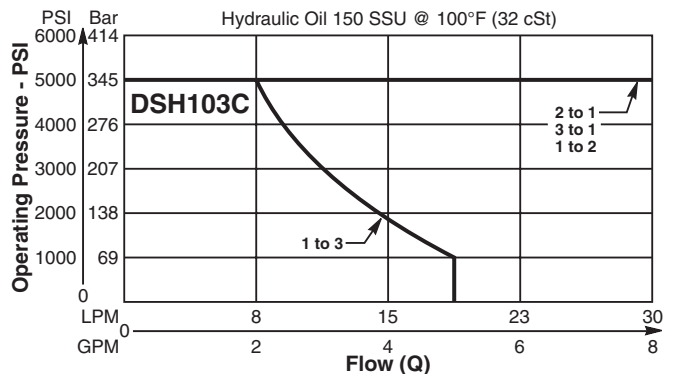

Pressure Drop vs. Flow (Through cartridge only)

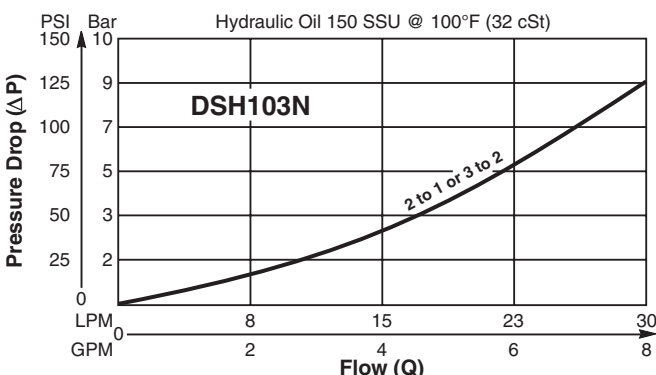

Shift Limit Characteristics (Min. Operating Voltage)

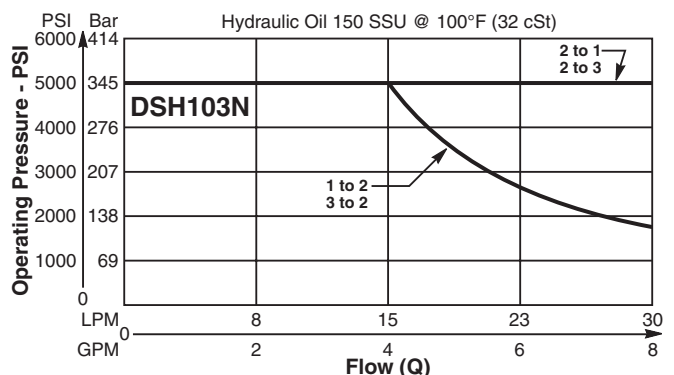

- CV** Check Valves
- SH** Shuttle Valves
- LM** Load/Motor Controls
- FC** Flow Controls
- PC** Pressure Controls
- LE** Logic Elements
- DC** Directional Controls
- MV** Manual Valves
- SV** Solenoid Valves
- PV** Proportional Valves
- CE** Coils & Electronics
- BC** Bodies & Cavities
- TD** Technical Data

Technical Information

- CV** Check Valves
- SH** Shuttle Valves
- LM** Load/Motor Controls
- FC** Flow Controls
- PC** Pressure Controls
- LE** Logic Elements
- DC** Directional Controls
- MV** Manual Valves
- SV** Solenoid Valves
- PV** Proportional Valves
- CE** Coils & Electronics
- BC** Bodies & Cavities
- TD** Technical Data

General Description

3-Way Spool Valves. For additional information see Technical Tips on pages SV1-SV6.

Features

- High flow capacity with reduced space requirements
- Standard valve bodies and common cavities
- One-piece encapsulated coil with minimal amperage draw
- No dynamic seals
- Variety of coil terminations
- All external parts zinc plated
- Manual override standard

Specifications

Rated Flow	DS163	N.O. 45.4 LPM (12 GPM)
		N.C. 49.2 LPM (13 GPM)
		Selector 41.6 LPM (11 GPM)
DS163B	N.O. 26.5 LPM (7 GPM)	
	N.C. 53.0 LPM (14 GPM)	
	Selector 56.8 LPM (15 GPM)	
Maximum Inlet Pressure	210 Bar (3000 PSI)	
Leakage at 150 SSU (32 cSt)	82 cc/min. (5 in ³ /min.)	
Minimum Operating Voltage	85% of rated voltage at 20°C (72°F).	
Response Time	Normally Closed up to 90 ms Normally Open up to 100 ms	
Cartridge Material	All parts steel. All operating parts hardened steel.	
Operating Temp. Range/Seals	-40°C to +93.3°C (Nitrile) (-40°F to +200°F) -31.7°C to +121.1°C (Fluorocarbon) (-25°F to +250°F)	
Fluid Compatibility/Viscosity	Mineral-based or synthetic with lubricating properties at viscosities of 45 to 2000 SSU (6 to 420 cSt)	
Filtration	ISO Code 16/13, SAE Class 4 or better	
Approx. Weight	.59 kg (1.3 lbs.)	
Cavity	C16-3 (See BC Section for more details)	
Form Tool	Rougher	NFT16-3R
	Finisher	NFT16-3F

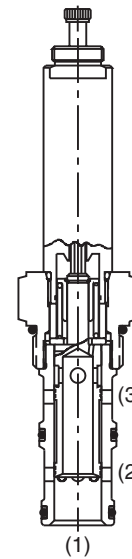
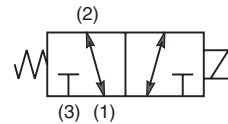
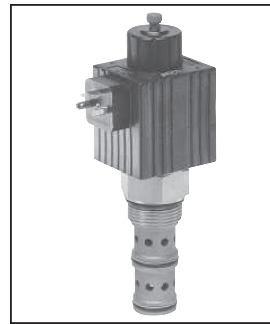

DS163

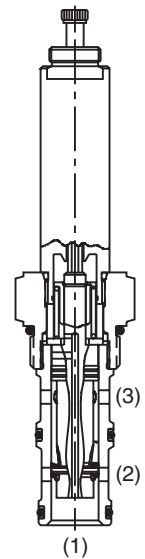

DS163B

Dimensions Millimeters (Inches)

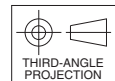
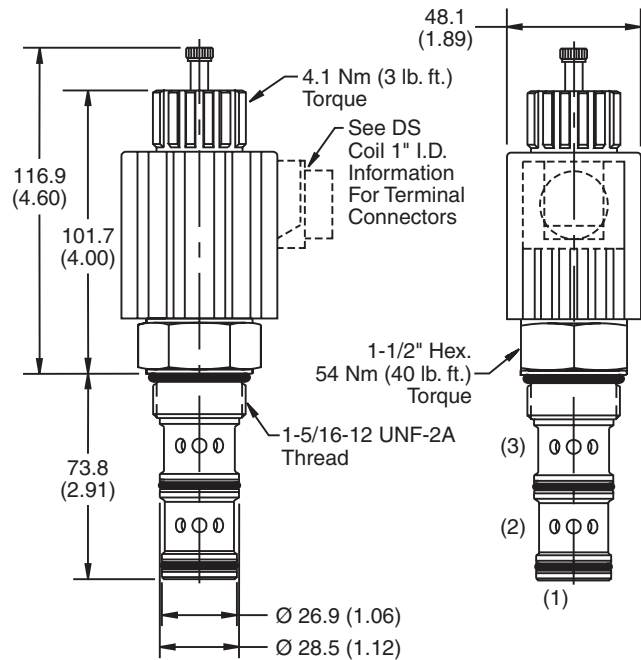

Performance Curves

Pressure Drop vs. Flow (Through cartridge only)

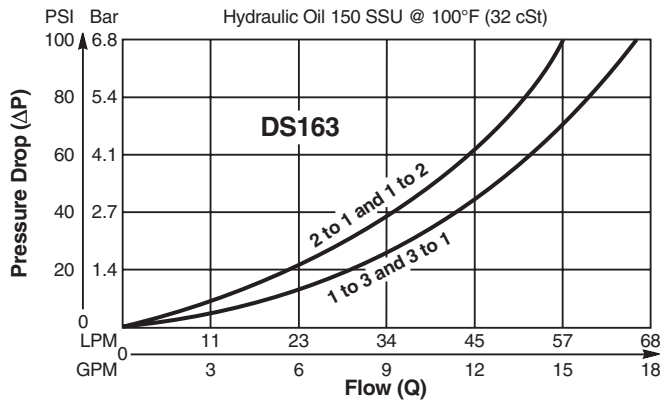

Shift Limit Characteristics (Min. Operating Voltage)

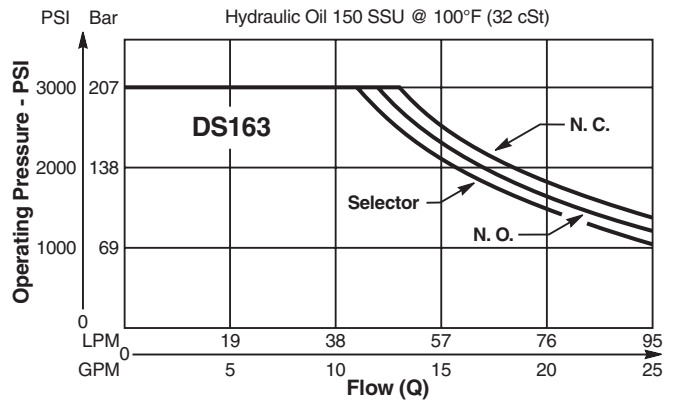

Pressure Drop vs. Flow (Through cartridge only)

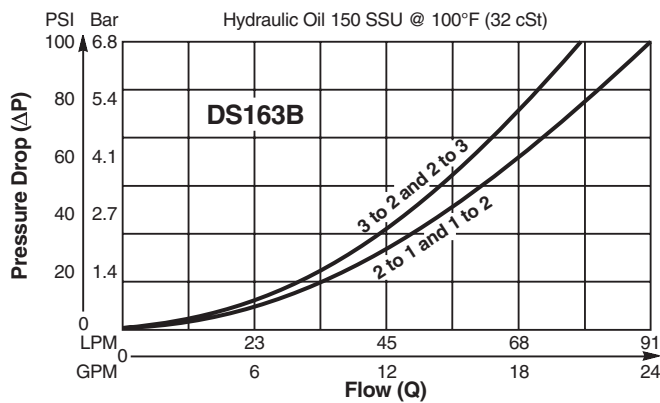

Shift Limit Characteristics (Min. Operating Voltage)

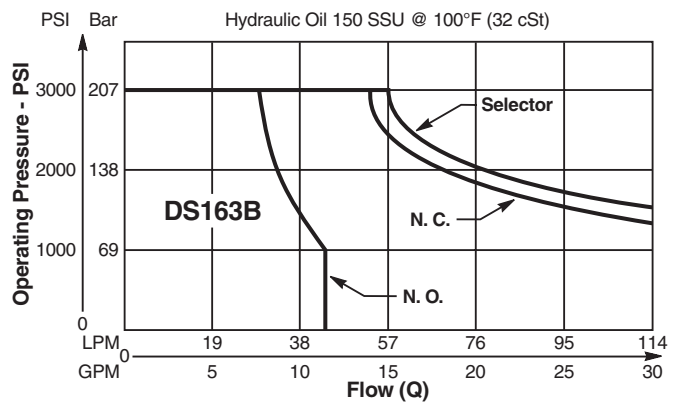

Ordering Information

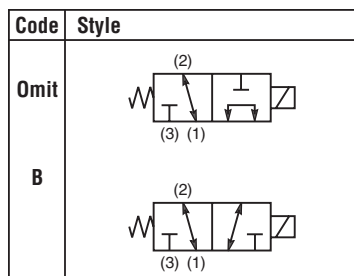
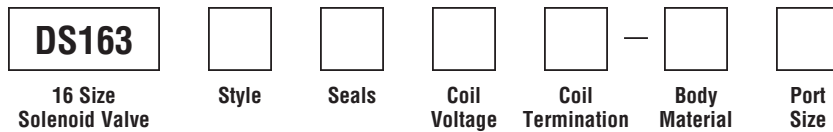

Code	Seals / Kit No.
Omit	Nitrile / (SK16-3)
V	Fluorocarbon / (SK16-3V)

Code	Coil Voltage
Omit	Without Coil
D012	12 VDC
D024	24 VDC
A120	120/110 VAC, 60/50 Hz

Code	Coil Termination
Omit	Without Coil
C	Conduit (AC Only)
D	DIN Plug Face
S	Dual Screw (DC Only)
W	Dual Lead (DC Only)

See DS coil 1" I.D. (42 watt)

Code	Body Material
Omit	Steel
A	Aluminum

Code	Port Size	Body Part No.
Omit	Cartridge Only	
12T	SAE-12	(B16-3-*12T)
16T	SAE-16	(B16-3-*16T)

* Add "A" for aluminum, omit for steel.

- CV Check Valves
- SH Shuttle Valves
- LM Load/Motor Controls
- FC Flow Controls
- PC Pressure Controls
- LE Logic Elements
- DC Directional Controls
- MV Manual Valves
- SV Solenoid Valves
- PV Proportional Valves
- CE Coils & Electronics
- BC Bodies & Cavities
- TD Technical Data

Technical Information

- CV** Check Valves
- SH** Shuttle Valves
- LM** Load/Motor Controls
- FC** Flow Controls
- PC** Pressure Controls
- LE** Logic Elements
- DC** Directional Controls
- MV** Manual Valves
- SV** Solenoid Valves
- PV** Proportional Valves
- CE** Coils & Electronics
- BC** Bodies & Cavities
- TD** Technical Data

General Description

4-Way Spool Valves. For additional information see Technical Tips on pages SV1-SV6.



Features

- High flow capacity with reduced space requirements
- Standard valve bodies and common cavities
- One-piece encapsulated coil with minimal amperage draw
- Manual overrides, seal variations and other options available
- No dynamic seals
- Variety of coil terminations
- Polyurethane "D"-Ring eliminates need for backup rings
- Nylon inserted jam-nut provides secure holding in high vibration applications
- All external parts zinc plated



DSL084B

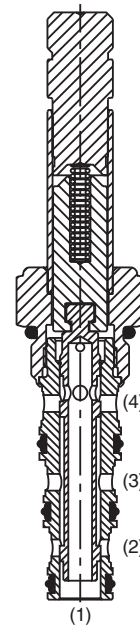
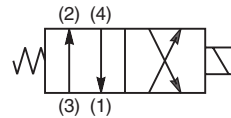

DSL084B

Specifications

Rated Flow	11-15 LPM (3-4 GPM)
Maximum Inlet Pressure	250 Bar (3600 PSI)
Leakage at 150 SSU (32 cSt)	160 cc/min. (10 in ³ /min.) at 250 Bar (3600 PSI)
Minimum Operating Voltage	85% of rated voltage at 20°C (72°F).
Response Time	Energized - 50 ms De-energized - 30 ms
Cartridge Material	All parts steel. All operating parts hardened steel.
Operating Temp. Range/Seals	-45°C to +93.3°C ("D"-Ring) (-50°F to +200°F) -31.7°C to +121.1°C (Fluorocarbon) (-25°F to +250°F)
Fluid Compatibility/Viscosity	Mineral-based or synthetic with lubricating properties at viscosities of 45 to 2000 SSU (6 to 420 cSt)
Filtration	ISO Code 16/13, SAE Class 4 or better
Approx. Weight	.13 kg (.29 lbs.)
Cavity	C08-4 (See BC Section for more details)
Form Tool	Rougher NFT08-4R Finisher NFT08-4F

Curve Selection Chart

SPOOL CODE	NEUTRAL					SHIFTED			
	4 to 1	3 to 2	2 to 1	3 to 1	3 to 4	4 to 1	3 to 2	2 to 1	3 to 4
B	4	3	—	—	—	—	—	2	4
E1	—	—	—	—	—	—	—	2	3
M	—	—	3	—	1	—	—	—	—
N	—	—	—	—	—	4	3	—	—

Performance Curves

Pressure Drop vs. Flow (Through cartridge only)

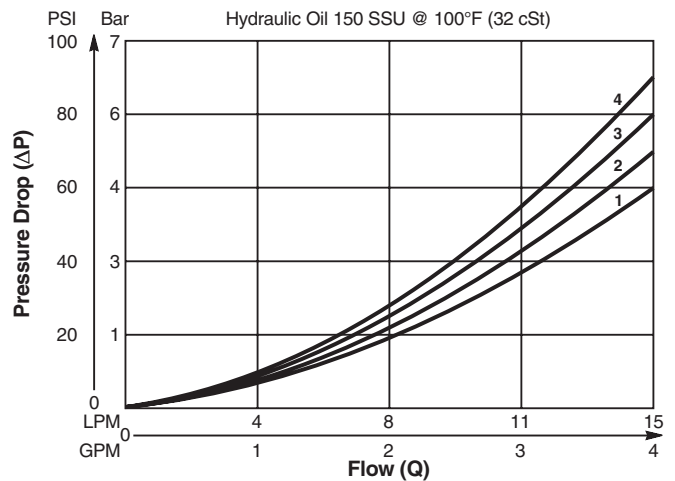

Shift Limit Characteristics (Min. Operating Voltage)

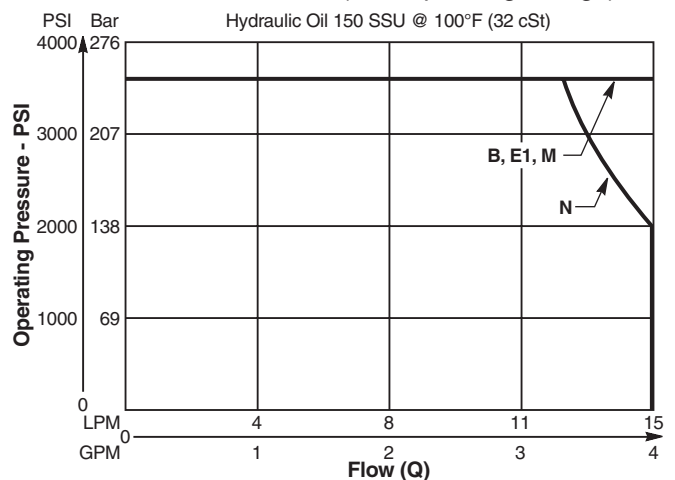

Dimensions Millimeters (Inches)

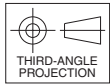
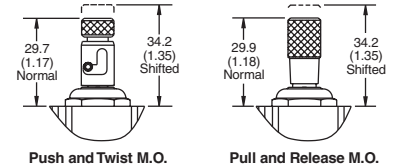
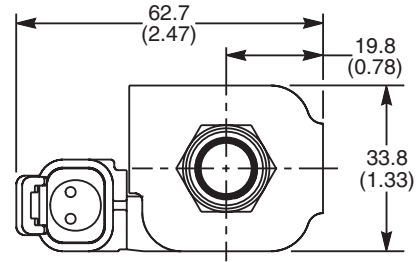
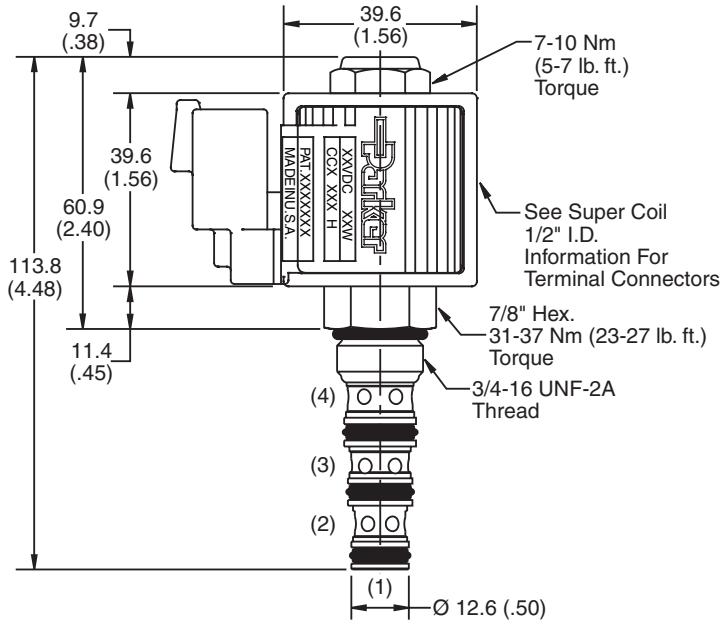

Ordering Information

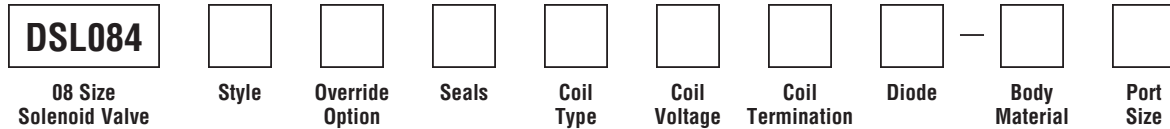

Code	Style
B	
N	
E1	
M	

Code	Override Options
Omit	None
P	Pull & Release
T	Push & Twist

Code	Seals / Kit No.
Omit	"D"-Ring / (SK08-4)
N	Nitrile / (SK08-4N)
V	Fluorocarbon / (SK08-4V)

Code	Coil Type
Omit	Without Coil
SP*	Super Coil - 19 Watts

*Recommended

Code	Coil Voltage
Omit	Without Coil
D012	12 VDC
D024	24 VDC
A120	120/110 VAC, 60/50 Hz
A240	240/220 VAC, 60/50 Hz

SP*	Coil Termination
Omit	Without Coil
C	Conduit With Leads
D	DIN Plug Face
A	Amp Jr. Timert
S	Dual Spade†
L	Dual Lead Wire†
LS	Sealed Lead Wire†
H	Molded Deutsch†

*Recommended
†DC Only

Code	Diode
Omit	None
R	Diode

Code	Body Material
Omit	Steel
A	Aluminum

Code	Port Size	Body Part No.
Omit	Cartridge Only	
4T	SAE-4	(B08-4-*4T)
6T	SAE-6	(B08-4-*6T)
6B	3/8" BSPG	(B08-4-*6B)

* Add "A" for aluminum, omit for steel.

Technical Information

- CV** Check Valves
- SH** Shuttle Valves
- LM** Load/Motor Controls
- FC** Flow Controls
- PC** Pressure Controls
- LE** Logic Elements
- DC** Directional Controls
- MV** Manual Valves
- SV** Solenoid Valves
- PV** Proportional Valves
- CE** Coils & Electronics
- BC** Bodies & Cavities
- TD** Technical Data

General Description

4-Way Spool Valves. For additional information see Technical Tips on pages SV1-SV6.



Features

- High flow capacity with reduced space requirements
- Standard valve bodies and common cavities
- One-piece encapsulated coil with minimal amperage draw
- Manual overrides, seal variations and other options available
- No dynamic seals
- Variety of coil terminations
- Polyurethane "D"-Ring eliminates need for backup rings
- Nylon inserted jam-nut provides secure holding in high vibration applications
- All external parts zinc plated

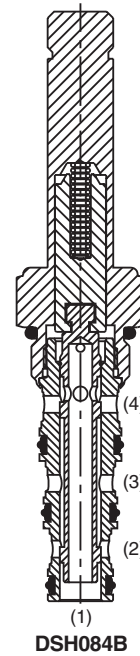
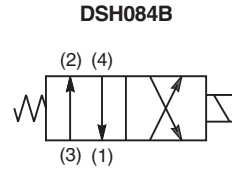

Specifications

Rated Flow	11-15 LPM (3-4 GPM)
Max. Inlet Pressure	350 Bar (5000 PSI)
Leakage at 150 SSU (32 cSt)	160 cc/min. (10 in ³ /min.) at 350 Bar (5000 PSI) DSH084B - 240 cc/min. (15 in ³ /min.)
Minimum Operating Voltage	85% of rated voltage at 20°C (72°F).
Response Time	Energized - 50 ms De-energized - 30 ms
Cartridge Material	All parts steel. All operating parts hardened steel.
Operating Temp. Range/Seals	-45°C to +93.3°C ("D"-Ring) (-50°F to +200°F) -31.7°C to +121.1°C (Fluorocarbon) (-25°F to +250°F)
Fluid Compatibility/Viscosity	Mineral-based or synthetic with lubricating properties at viscosities of 45 to 2000 SSU (6 to 420 cSt)
Filtration	ISO Code 16/13, SAE Class 4 or better
Approx. Weight	.13 kg (.29 lbs.)
Cavity	C08-4 (See BC Section for more details)
Form Tool	Rougher NFT08-4R Finisher NFT08-4F

Curve Selection Chart

SPOOL CODE	NEUTRAL					SHIFTED				
	4 to 1	3 to 2	2 to 1	3 to 1	3 to 4	4 to 1	3 to 2	2 to 1	3 to 4	
B	4	3	—	—	—	—	—	2	4	
E1	—	—	—	—	—	—	—	2	3	
M	—	—	3	—	1	—	—	—	—	
N	—	—	—	—	—	4	3	—	—	

Performance Curves

Pressure Drop vs. Flow (Through cartridge only)

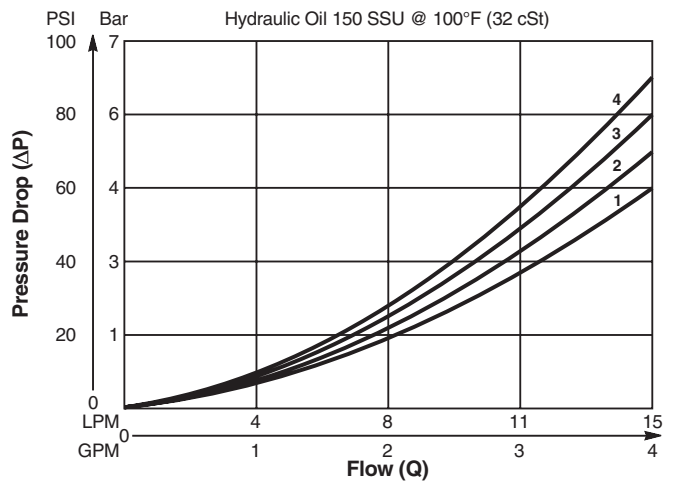

Shift Limit Characteristics (Min. Operating Voltage)

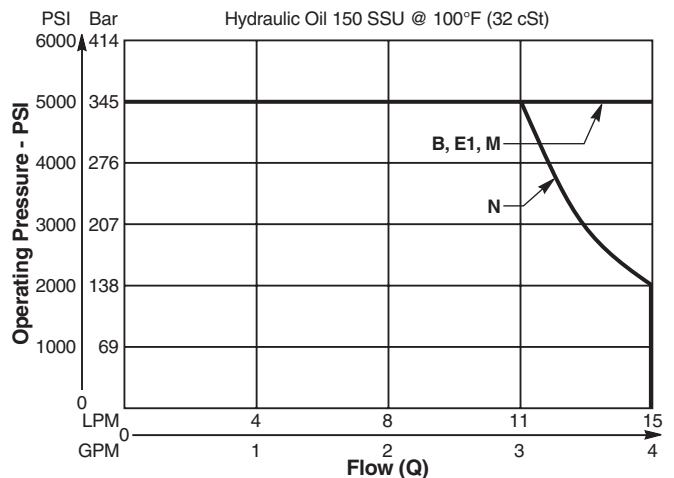

Dimensions Millimeters (Inches)

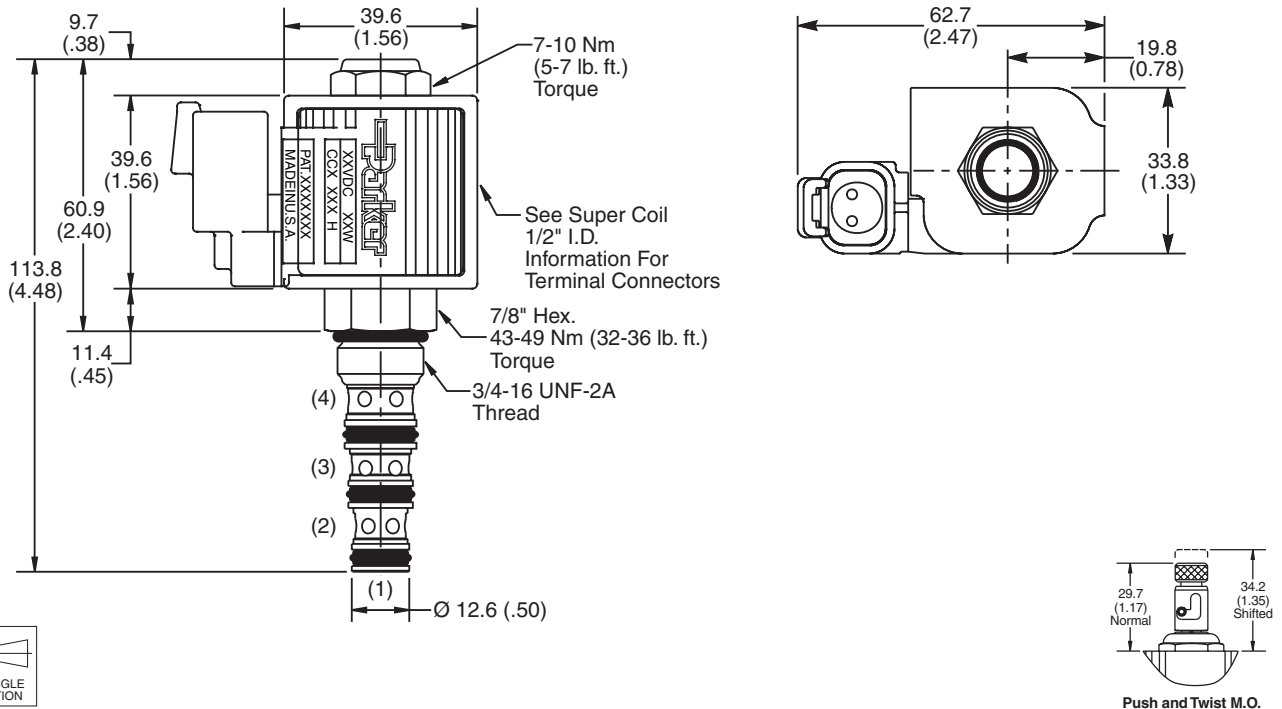

Ordering Information

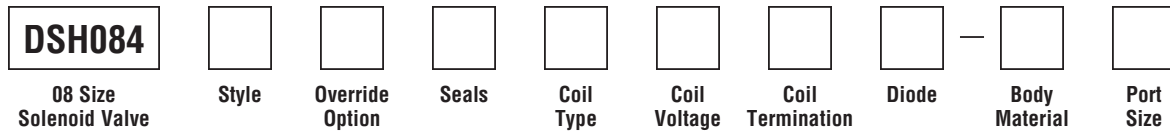

Code	Style
B	
N	
E1	
M	

Code	Override Options
Omit	None
T	Push & Twist*

**Requires Super Coil*

Code	Seals / Kit No.
Omit	"D"-Ring / (SK08-4)
N	Nitrile / (SK08-4N)
V	Fluorocarbon / (SK08-4V)

Code	Coil Type
Omit	Without Coil
SP*	Super Coil - 19 Watts

**Recommended*

Code	Coil Voltage
Omit	Without Coil
D012	12 VDC
D024	24 VDC
A120	120/110 VAC, 60/50 Hz
A240	240/220 VAC, 60/50 Hz

SP*	Coil Termination
Omit	Without Coil
C	Conduit With Leads
D	DIN Plug Face
A	Amp Jr. Timert
S	Dual Spade†
L	Dual Lead Wire†
LS	Sealed Lead Wire†
H	Molded Deutsch†

**Recommended
†DC Only*

Code	Diode
Omit	None
R	Diode

Code	Body Material
Omit	Steel
A	Aluminum

Code	Port Size	Body Part No.
Omit	Cartridge Only	
4T	SAE-4	(B08-4-*4T)
6T	SAE-6	(B08-4-*6T)
6B	3/8" BSPG	(B08-4-*6B)

** Add "A" for aluminum, omit for steel.*

Technical Information

- CV** Check Valves
- SH** Shuttle Valves
- LM** Load/Motor Controls
- FC** Flow Controls
- PC** Pressure Controls
- LE** Logic Elements
- DC** Directional Controls
- MV** Manual Valves
- SV** Solenoid Valves
- PV** Proportional Valves
- CE** Coils & Electronics
- BC** Bodies & Cavities
- TD** Technical Data

General Description

4-Way Spool Valves. For additional information see Technical Tips on pages SV1-SV6.



Features

- High flow capacity with reduced space requirements
- Standard valve bodies and common cavities
- One-piece encapsulated coil with minimal amperage draw
- Manual overrides, seal variations and other options available
- No dynamic seals
- Variety of coil terminations
- Polyurethane "D"-Ring
- All external parts zinc plated

Specifications

Rated Flow	27-38 LPM (7-10 GPM) See Shift Limit Characteristics
Maximum Inlet Pressure	250 Bar (3600 PSI)
Leakage at 150 SSU (32 cSt)	230 cc/min (14 in ³ /min)
Minimum Operating Voltage	85% of rated voltage at 20°C (72°F).
Response Time	Energized - 30 - 60 ms De-energized - 30 - 60 ms
Cartridge Material	All parts steel. All operating parts hardened steel.
Operating Temp. Range/Seals	-45°C to +93.3°C ("D"-Ring) (-50°F to +200°F) -31.7°C to +121.1°C (Fluorocarbon) (-25°F to +250°F)
Fluid Compatibility/Viscosity	Mineral-based or synthetic with lubricating properties at viscosities of 45 to 2000 SSU (6 to 420 cSt)
Filtration	ISO Code 16/13, SAE Class 4 or better
Approx. Weight	.20 kg (.44 lbs.)
Cavity	C10-4 (See BC Section for more details)
Form Tool	Rougher NFT10-4R Finisher NFT10-4F



DSL104B

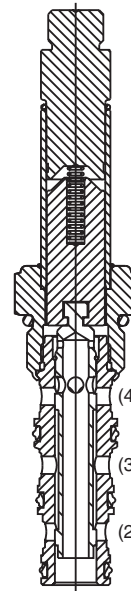
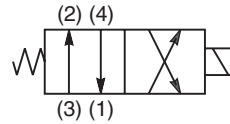

DSL104B

Performance Curves

Pressure Drop vs. Flow (Through cartridge only)

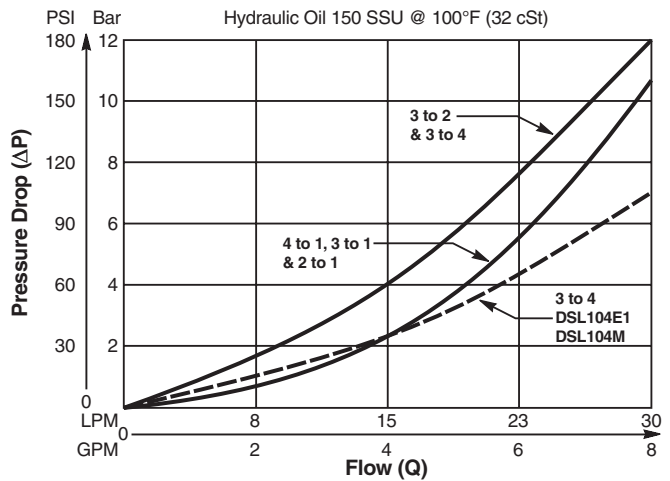

Shift Limit Characteristics (Min. Operating Voltage)

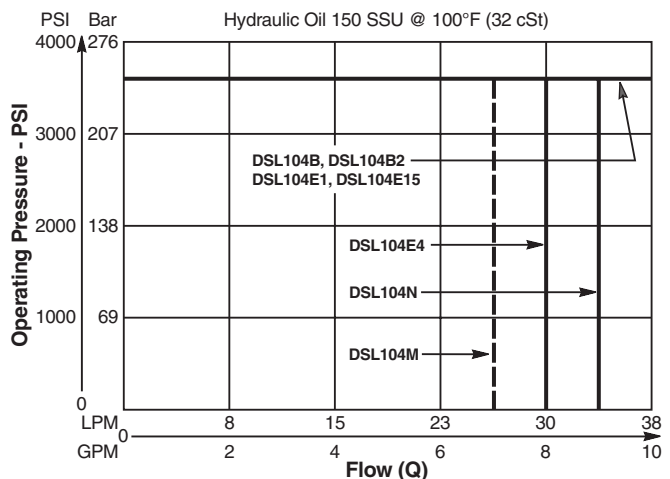

Dimensions Millimeters (Inches)

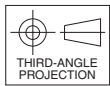
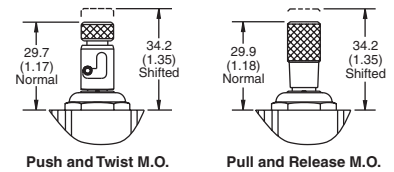
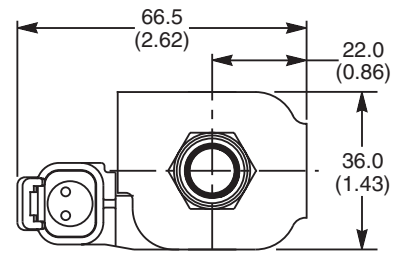
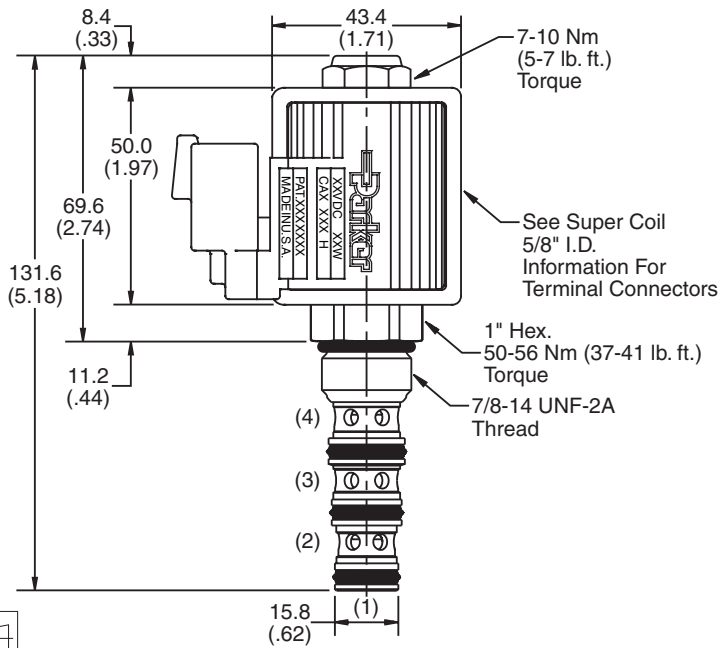

Ordering Information

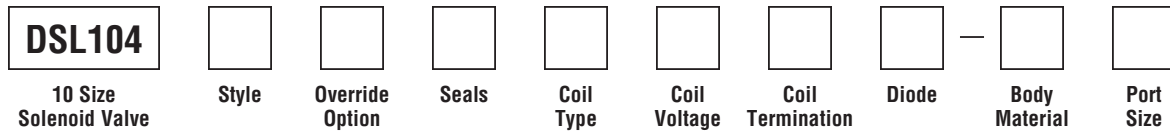

Code	Style
B	
B2	
E1	
E4	
E15	
M	
N	

Code	Override Options
Omit	None
P	Pull & Release
T	Push & Twist

Code	Seals / Kit No.
Omit	"D"-Ring / (SK10-4)
N	Nitrile / (SK10-4N)
V	Fluorocarbon / (SK10-4V)

Code	Coil Type
Omit	Without Coil
SP*	Super Coil - 28 Watts

*Recommended

Code	Coil Voltage
Omit	Without Coil
D012	12 VDC
D024	24 VDC
A120	120/110 VAC, 60/50 Hz
A240	240/220 VAC, 60/50 Hz

SP*	Coil Termination
Omit	Without Coil
C	Conduit With Leads
D	DIN Plug Face
A	Amp Jr. Timert†
S	Dual Spade†
L	Dual Lead Wire†
LS	Sealed Lead Wire†
H	Molded Deutsch†

*Recommended
 †DC Only

Code	Diode
Omit	None
R	Diode

Code	Body Material
Omit	Steel
A	Aluminum

Code	Port Size	Body Part No.
Omit	Cartridge Only	
6P	3/8" NTPF	(B10-4-*6P)
6T	SAE-6	(B10-4-*6T)
8T	SAE-8	(B10-4-*8T)
6B	3/8" BSPG	(B10-4-6B)†

* Add "A" for aluminum, omit for steel.
 † Steel bodies only

Technical Information

- CV** Check Valves
- SH** Shuttle Valves
- LM** Load/Motor Controls
- FC** Flow Controls
- PC** Pressure Controls
- LE** Logic Elements
- DC** Directional Controls
- MV** Manual Valves
- SV** Solenoid Valves
- PV** Proportional Valves
- CE** Coils & Electronics
- BC** Bodies & Cavities
- TD** Technical Data

General Description

4-Way Spool Valves. For additional information see Technical Tips on pages SV1-SV6.



Features

- High flow capacity with reduced space requirements
- Standard valve bodies and common cavities
- One-piece encapsulated coil with minimal amperage draw
- Manual overrides, seal variations and other options available
- No dynamic seals
- Variety of coil terminations
- Polyurethane "D"-Ring eliminates need for backup rings
- Nylon inserted jam-nut provides secure holding in high vibration applications
- All external parts zinc plated



DSH104B

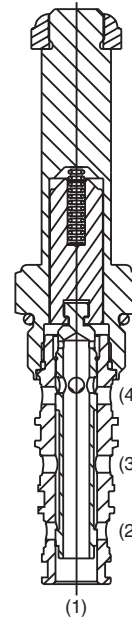
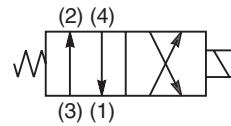

DSH104B

Specifications

Rated Flow	25 - 38 LPM (6.5 - 10 GPM) See Shift Limit Characteristics
Maximum Inlet Pressure	350 Bar (5000 PSI)
Leakage at 150 SSU (32 cSt)	160 cc/min (10 in ³ /min) DSH104B - 320 cc/min (19.5 in ³ /min)
Minimum Operating Voltage	85% of rated voltage at 20°C (72°F).
Response Time	Energized - 30 - 60 ms De-energized - 30 - 60 ms
Cartridge Material	All parts steel. All operating parts hardened steel.
Operating Temp. Range/Seals	-45°C to +93.3°C ("D"-Ring) (-50°F to +200°F) -31.7°C to +121.1°C (Fluorocarbon) (-25°F to +250°F)
Fluid Compatibility/Viscosity	Mineral-based or synthetic with lubricating properties at viscosities of 45 to 2000 SSU (6 to 420 cSt)
Filtration	ISO Code 16/13, SAE Class 4 or better
Approx. Weight	.20 kg (.44 lbs.)
Cavity	C10-4 (See BC Section for more details)
Form Tool	Rougher NFT10-4R Finisher NFT10-4F

Performance Curves

Pressure Drop vs. Flow (Through cartridge only)

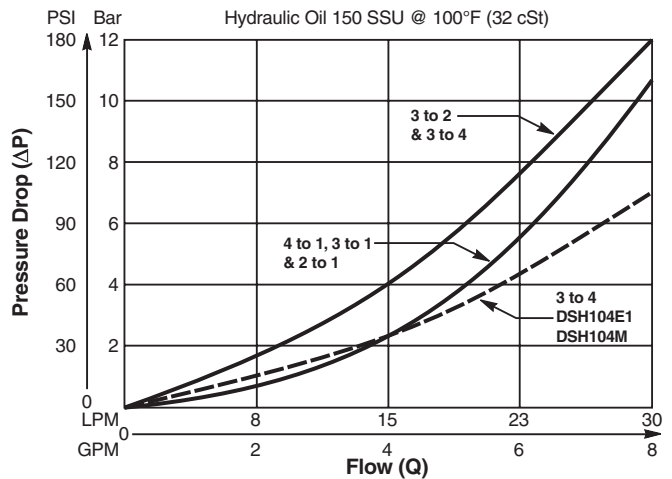

Shift Limit Characteristics (Min. Operating Voltage)

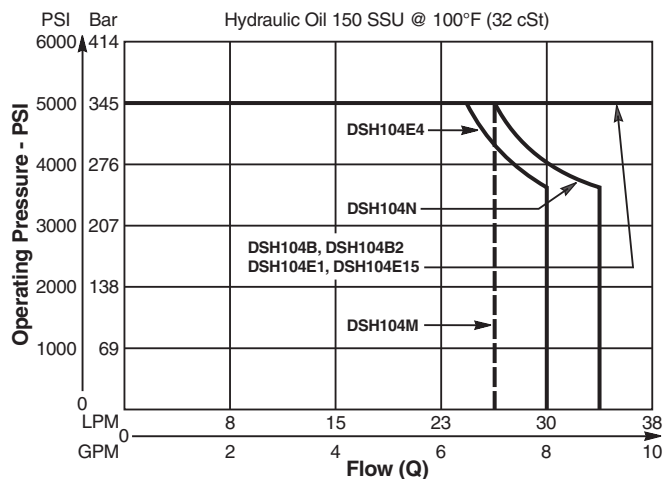

Dimensions Millimeters (Inches)

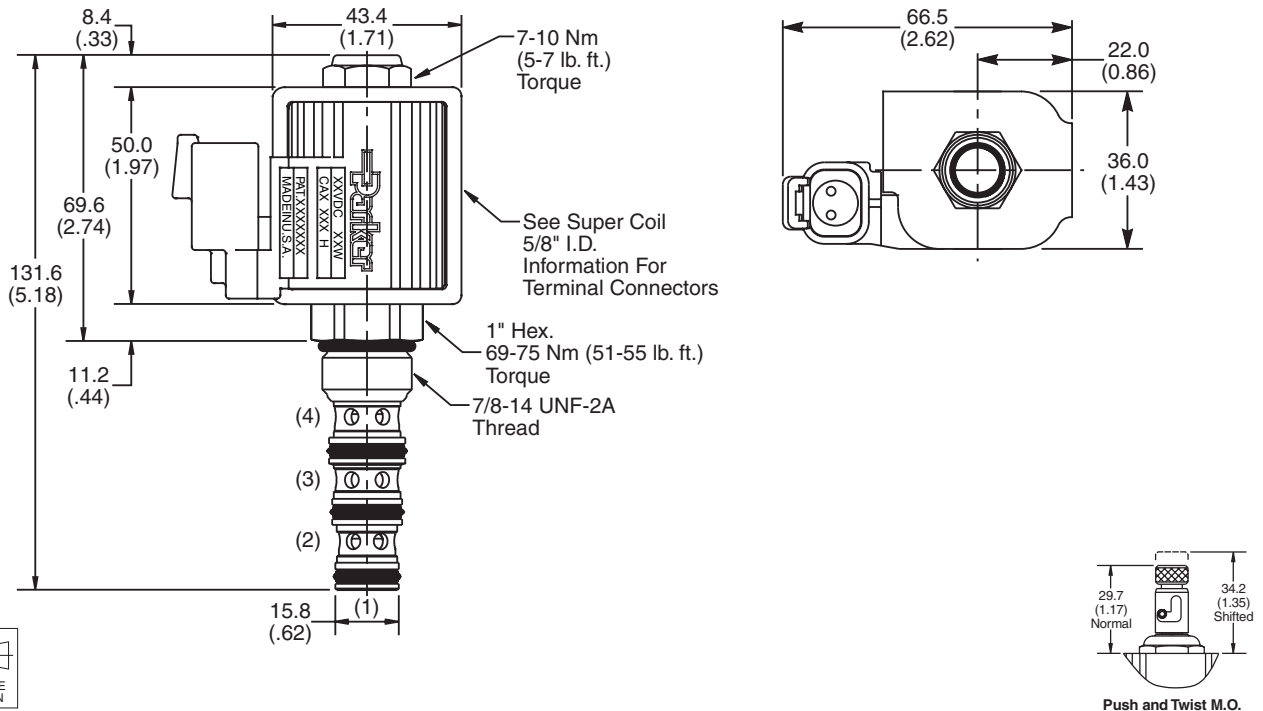

Ordering Information

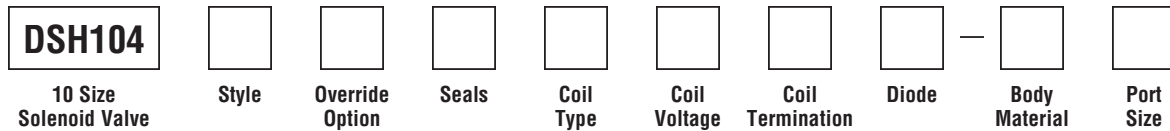

Code	Style
B	
B2	
E1	
E4	
E15	
M	
N	

Code	Override Options
Omit	None
T	Push & Twist

Code	Seals / Kit No.
Omit	"D"-Ring / (SK10-4)
N	Nitrile / (SK10-4N)
V	Fluorocarbon / (SK10-4V)

Code	Coil Type
Omit	Without Coil
SP*	Super Coil - 28 Watts

*Recommended

Code	Coil Voltage
Omit	Without Coil
D012	12 VDC
D024	24 VDC
A120	120/110 VAC, 60/50 Hz
A240	240/220 VAC, 60/50 Hz

SP*	Coil Termination
Omit	Without Coil
C	Conduit With Leads
D	DIN Plug Face
A	Amp Jr. Timert
S	Dual Spade†
L	Dual Lead Wire†
LS	Sealed Lead Wire†
H	Molded Deutsch†

*Recommended
 †DC Only

Code	Diode
Omit	None
R	Diode

Code	Body Material
Omit	Steel
A	Aluminum

Code	Port Size	Body Part No.
Omit	Cartridge Only	
6P	3/8" NTPF	(B10-4-*6P)
6T	SAE-6	(B10-4-*6T)
8T	SAE-8	(B10-4-*8T)
6B	3/8" BSPG	(B10-4-6B)†

* Add "A" for aluminum, omit for steel.
 † Steel bodies only

Technical Information

CV

Check Valves

SH

Shuttle Valves

LM

Load/Motor Controls

FC

Flow Controls

PC

Pressure Controls

LE

Logic Elements

DC

Directional Controls

MV

Manual Valves

SV

Solenoid Valves

PV

Proportional Valves

CE

Coils & Electronics

BC

Bodies & Cavities

TD

Technical Data

General Description

4-Way Spool Valves. For additional information see Technical Tips on pages SV1-SV6.

Features

- High flow capacity with reduced space requirements
- Standard valve bodies and common cavities
- One-piece encapsulated coil with minimal amperage draw
- Seal variations and other options available
- No dynamic seals
- Variety of coil terminations
- Nylon inserted jam-nut provides secure holding in high vibration applications
- All external parts zinc plated

Application Note

This valve is a pilot operated spool type valve. It does not require a separate pilot supply, but does require that the work port pressure or the inlet pressure is 40-60 psi higher than port 1. In an open flowing condition, with zero load and low flow, it will require a 4-6 gpm flow to create internal pilot pressure to shift. If load pressure or system pressure is 40-60 psi higher than tank, the valve will shift. Ultimately, the valve shifts based upon pressure differential from port 3 to port 1 of 40-60 psi.

Specifications

Rated Flow	114 LPM (30 GPM)
Maximum Inlet Pressure	350 Bar (5000 PSI)
Leakage at 150 SSU (32 cSt)	350 cc/min (21 in ³ /min) De-Energ. 5.6 LPM (1.5 GPM) Energized Pilot Flow @ 207 Bar (3000 PSI)
Minimum Operating Voltage	85% of rated voltage at 20°C (72°F).
Response Time	Pull In - 600 ms Drop Out - 130 ms
Cartridge Material	All parts steel. All operating parts hardened steel.
Operating Temp. Range/Seals	-40°C to +93.3°C (Nitrile) (-40°F to +200°F) -31.7°C to +121.1°C (Fluorocarbon) (-25°F to +250°F)
Fluid Compatibility/Viscosity	Mineral-based or synthetic with lubricating properties at viscosities of 45 to 2000 SSU (6 to 420 cSt)
Filtration	ISO Code 16/13, SAE Class 4 or better
Approx. Weight	.59 kg (1.3 lbs.)
Cavity	C16-4 (See BC Section for more details)
Form Tool	Rougher NFT16-4R Finisher NFT16-4F

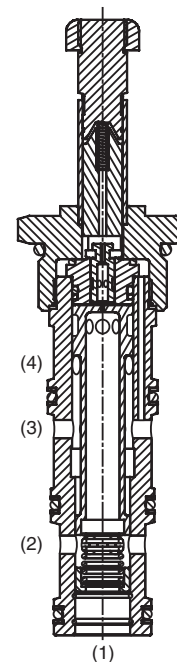
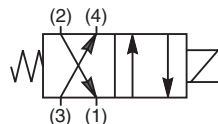

Performance Curves

Pressure Drop vs. Flow (Through cartridge only)

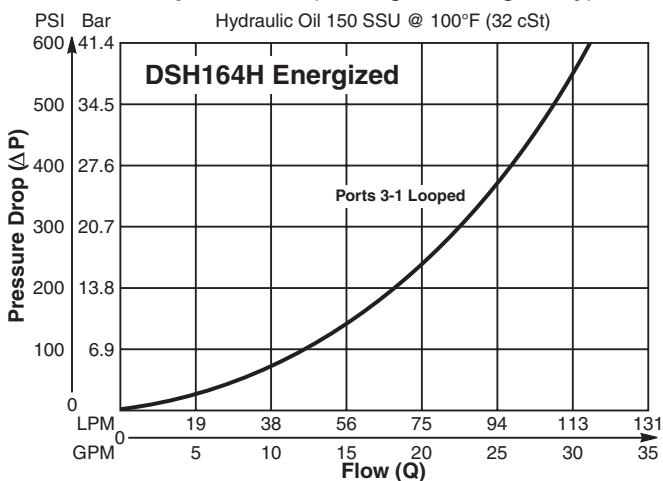

Pressure Drop vs. Flow (Through cartridge only)

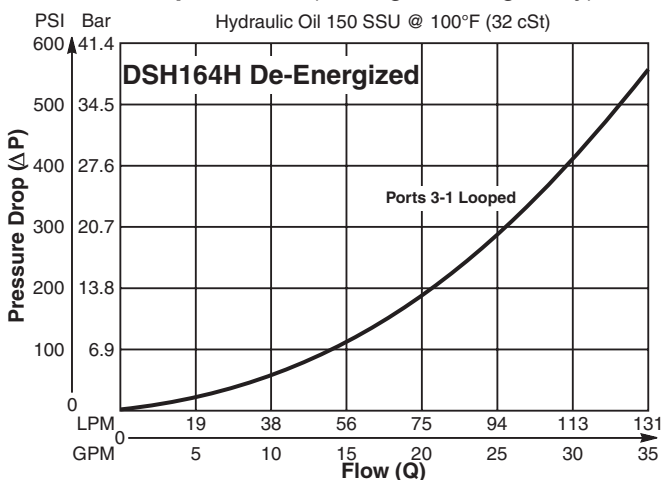

Technical Information

Dimensions Millimeters (Inches)

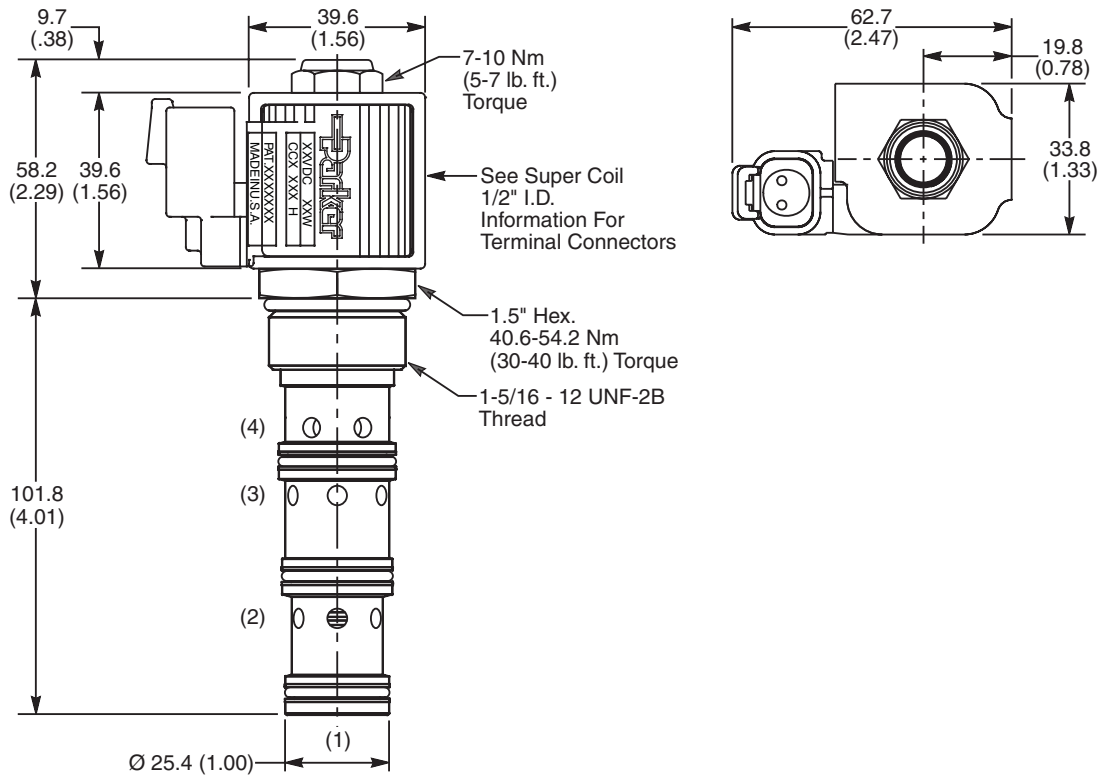

Ordering Information

DSH164 **H**

16 Size Solenoid Valve **Style** **Seals** **Coil Type** **Coil Voltage** **Coil Termination** **Diode** **Body Material** **Port Size**

Code	Style
H	

Code	Seals / Kit No.
N	Nitrile / (SK10-4N)
V	Fluorocarbon / (SK10-4V)

Code	Coil Type
Omit	Without Coil
SP*	Super Coil - 19 Watts

**Recommended*

Code	Coil Voltage
Omit	Without Coil
D012	12 VDC
D024	24 VDC
A120	120/110 VAC, 60/50 Hz
A240	240/220 VAC, 60/50 Hz

SP* Coil	Coil Termination
Omit	Without Coil
C	Conduit With Leads
D	DIN Plug Face
A	Amp Jr. Timer†
S	Dual Spade†
L	Dual Lead Wire†
LS	Sealed Lead Wire†
H	Molded Deutsch†

**Recommended
†DC Only*

Code	Diode
Omit	None
R	Diode

Code	Body Material
Omit	Steel
A	Aluminum

Code	Port Size	Body Part No.
Omit	Cartridge Only	
16T	SAE-16	(B16-4-*16T)

** Add "A" for aluminum, omit for steel.*

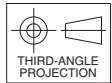

Technical Information

- CV** Check Valves
- SH** Shuttle Valves
- LM** Load/Motor Controls
- FC** Flow Controls
- PC** Pressure Controls
- LE** Logic Elements
- DC** Directional Controls
- MV** Manual Valves
- SV** Solenoid Valves
- PV** Proportional Valves
- CE** Coils & Electronics
- BC** Bodies & Cavities
- TD** Technical Data

General Description

4-Way, 3 Position, Closed Center Spool Valve.
For additional information see Technical Tips on pages SV1-SV6.

Features

- Designed to operate double acting cylinders, pilot circuits and bi-directional motors, etc.
- High flow capacity with reduced space requirements
- High pressure capability to 350 Bar (5000 PSI)
- One piece cartridge housing ensures internal concentricity
- Coil: Waterproof, hermetically sealed, requires no O’Rings; Symmetrical coil can be reversed without affecting performance.
- Manual override available

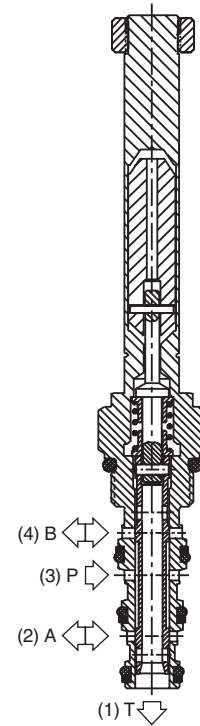
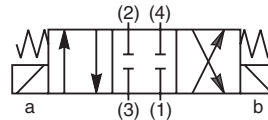
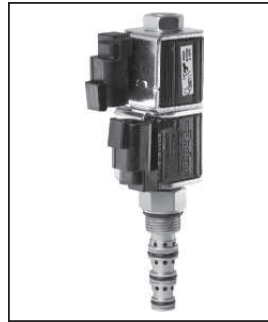

Specifications

Rated Flow (At 70 PSI ΔP)	High Flow/Pressure ('SP' Coil) 17 LPM (4.5 GPM)
Maximum Inlet Pressure	'SP' Coil 350 Bar (5000 PSI)
Maximum Tank Pressure	210 Bar (3000 PSI)
Cartridge Material	All parts steel. All operating parts hardened steel.
Operating Temp. Range/Seals	-40°C to +93.3°C (Nitrile) (-40°F to +200°F) -31.7°C to +121.1°C (Fluorocarbon) (-25°F to +250°F)
Fluid Compatibility/ Viscosity	Mineral-based or synthetic with lubricating properties at viscosities of 45 to 2000 SSU (6 to 420 cSt)
Filtration	ISO Code 16/13, SAE Class 4 or better
Approx. Weight	.18 kg (.40 lbs.)
Cavity	C08-4 (See BC Section for more details)

Performance Curves

Pressure Drop vs. Flow (Through cartridge only)

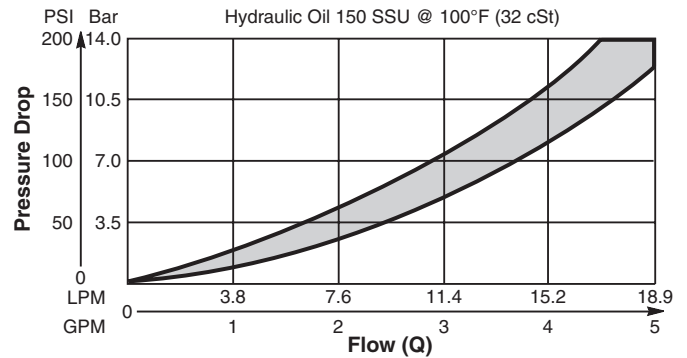

Operating Limits (Measured at 75% of Nominal Current)

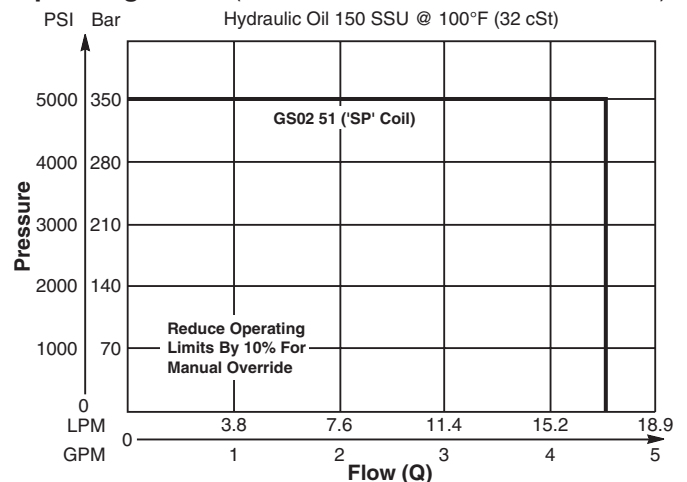

Dimensions Millimeters (Inches)

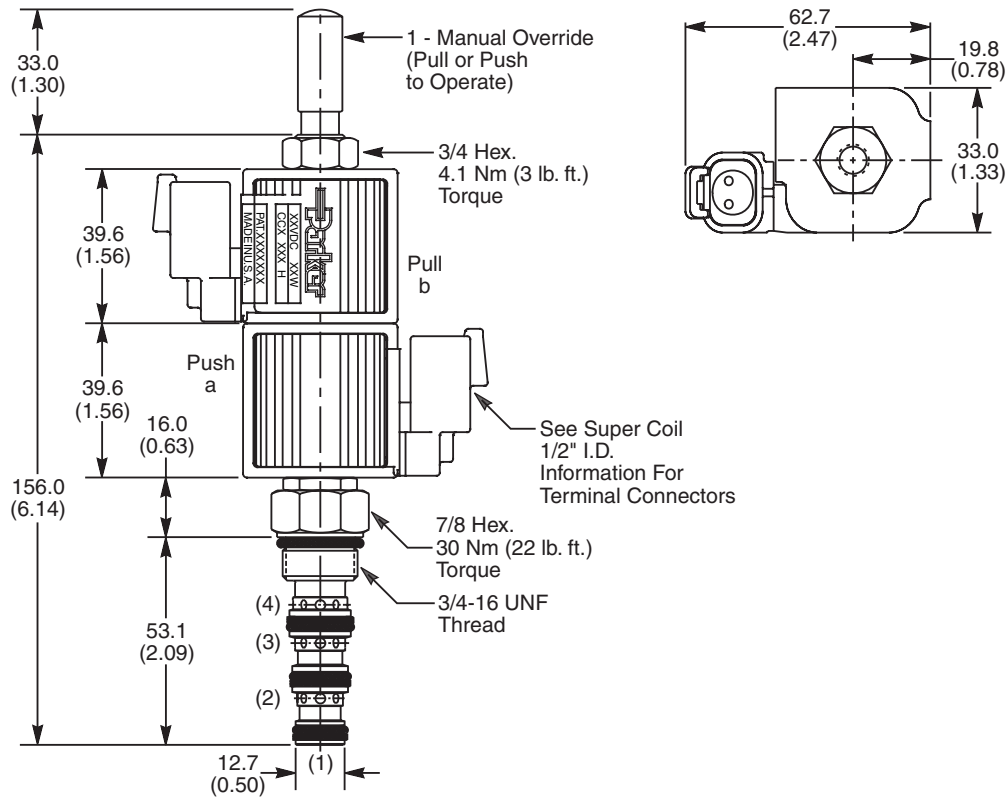

Ordering Information

GS02	51								
08 Size Solenoid Valve	Style	Override Option	Screen	Seals	Coil Type	Coil Voltage	Coil Termination	Body Material	Port Size

Code	Style
51	High Flow and Pressure ('SP' Coil)

Code	Override Options
0	Not Required
1	Manual Override
2	Detented M.O.

Code	Screen
0	Not Available

Code	Seals / Kit No.
N	Nitrile / Buna-N (Std.) (SK30078N-1)
V	Fluorocarbon / (SK30078V-1)

Code	Coil Type
Omit	Without Coil
SP	Super Coil - 19 Watts

Code	Coil Voltage
Omit	Without Coil
D012	12 VDC
D024	24 VDC
A120	120 VAC, 60/50 Hz
A240	240 VAC, 60/50 Hz*

*22 Watts

Code	Coil Termination
Omit	Without Coil
C	Conduit With Leads
D	DIN Plug Face
A	Amp Jr. Timer*
S	Dual Spade*
L	Dual Lead Wire*
SL	Sealed Lead Wire*
H	Molded Deutsch*

See Super Coil 1/2" I.D.
*DC Only

Code	Body Material
Omit	Steel
A	Aluminum

Code	Port Size	Body Part No.
Omit	Cartridge Only	
6T	SAE-6	(B08-4-*6T)
6B	3/8" BSPG	(B08-4-*6B)

* Add "A" for aluminum, omit for steel.

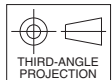

- CV** Check Valves
- SH** Shuttle Valves
- LM** Load/Motor Controls
- FC** Flow Controls
- PC** Pressure Controls
- LE** Logic Elements
- DC** Directional Controls
- MV** Manual Valves
- SV** Solenoid Valves
- PV** Proportional Valves
- CE** Coils & Electronics
- BC** Bodies & Cavities
- TD** Technical Data

Technical Information

- CV** Check Valves
- SH** Shuttle Valves
- LM** Load/Motor Controls
- FC** Flow Controls
- PC** Pressure Controls
- LE** Logic Elements
- DC** Directional Controls
- MV** Manual Valves
- SV** Solenoid Valves
- PV** Proportional Valves
- CE** Coils & Electronics
- BC** Bodies & Cavities
- TD** Technical Data

General Description

4-Way, 3 Position, Floating Center Spool Valve.
For additional information see Technical Tips on pages SV1-SV6.

Features

- Designed to operate double acting cylinders, pilot circuits and bi-directional motors, etc.
- High flow capacity with reduced space requirements
- High pressure capability to 350 Bar (5000 PSI)
- One piece cartridge housing ensures internal concentricity
- Coil: Waterproof, hermetically sealed, requires no O’Rings; Symmetrical coil can be reversed without affecting performance.
- Manual override available

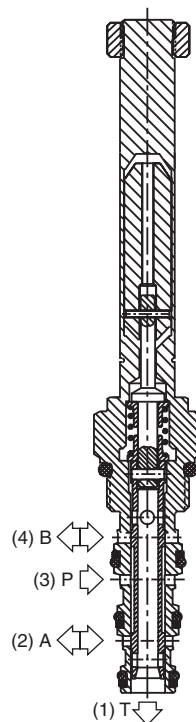
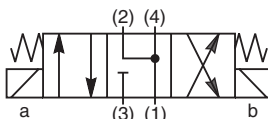

Specifications

Rated Flow (At 70 PSI ΔP)	High Flow/Pressure ('SP' Coil) 15 LPM (4.0 GPM)
Maximum Inlet Pressure	'SP' Coil 350 Bar (5000 PSI)
Maximum Tank Pressure	210 Bar (3000 PSI)
Cartridge Material	All parts steel. All operating parts hardened steel.
Operating Temp. Range/Seals	-40°C to +93.3°C (Nitrile) (-40°F to +200°F) -31.7°C to +121.1°C (Fluorocarbon) (-25°F to +250°F)
Fluid Compatibility/ Viscosity	Mineral-based or synthetic with lubricating properties at viscosities of 45 to 2000 SSU (6 to 420 cSt)
Filtration	ISO Code 16/13, SAE Class 4 or better
Approx. Weight	.18 kg (.40 lbs.)
Cavity	C08-4 (See BC Section for more details)

Performance Curves

Pressure Drop vs. Flow (Through cartridge only)

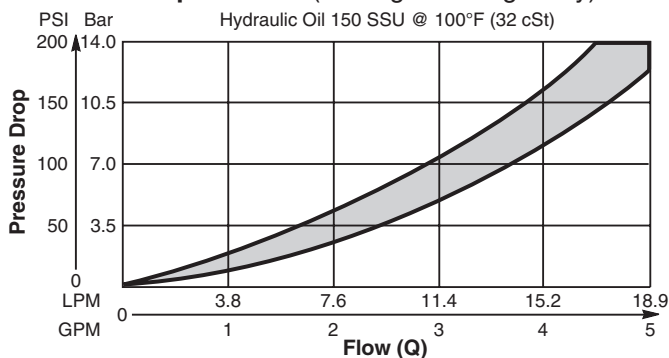

Operating Limits (Measured at 75% of Nominal Current)

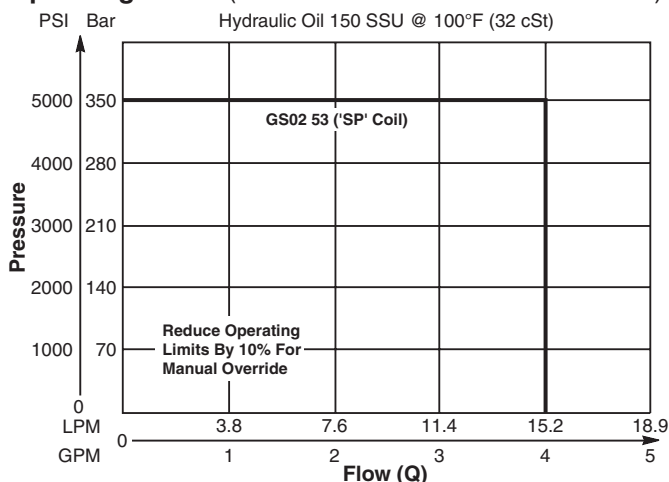

Dimensions Millimeters (Inches)

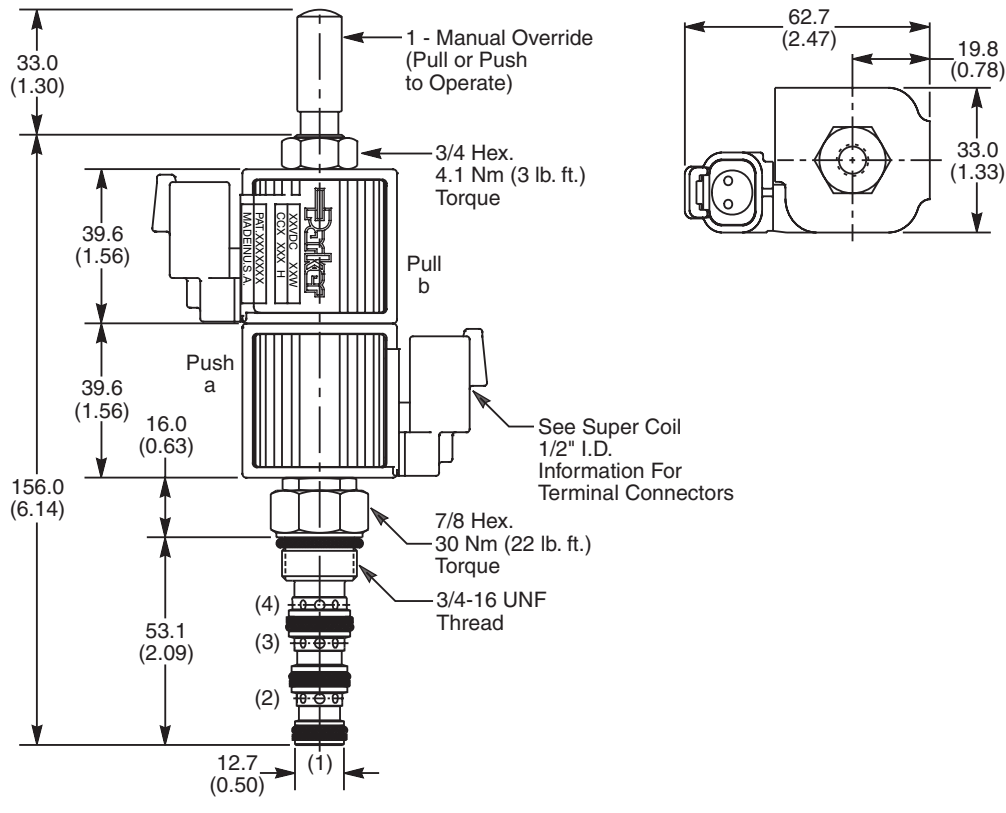

Ordering Information

GS02	53								
08 Size Solenoid Valve	Style	Override Option	Screen	Seals	Coil Type	Coil Voltage	Coil Termination	Body Material	Port Size

Code	Style
53	High Flow and Pressure ('SP' Coil)

Code	Override Options
0	Not Required
1	Manual Override
2	Detented M.O.

Code	Screen
0	Not Available

Code	Seals / Kit No.
N	Nitrile / Buna-N (Std.) (SK30078N-1)
V	Fluorocarbon / (SK30078V-1)

Code	Coil Type
Omit	Without Coil
SP	Super Coil - 19 Watts

Code	Coil Voltage
Omit	Without Coil
D012	12 VDC
D024	24 VDC
A120	120 VAC, 60/50 Hz
A240	240 VAC, 60/50 Hz*

*22 Watts

Code	Coil Termination
Omit	Without Coil
C	Conduit With Leads
D	DIN Plug Face
A	Amp Jr. Timer*
S	Dual Spade*
L	Dual Lead Wire*
SL	Sealed Lead Wire*
H	Molded Deutsch*

See Super Coil 1/2" I.D.
*DC Only

Code	Body Material
Omit	Steel
A	Aluminum

Code	Port Size	Body Part No.
Omit	Cartridge Only	
6T	SAE-6	(B08-4-*6T)
6B	3/8" BSPG	(B08-4-*6B)

* Add "A" for aluminum, omit for steel.

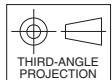

- CV** Check Valves
- SH** Shuttle Valves
- LM** Load/Motor Controls
- FC** Flow Controls
- PC** Pressure Controls
- LE** Logic Elements
- DC** Directional Controls
- MV** Manual Valves
- SV** Solenoid Valves
- PV** Proportional Valves
- CE** Coils & Electronics
- BC** Bodies & Cavities
- TD** Technical Data

Technical Information

- CV** Check Valves
- SH** Shuttle Valves
- LM** Load/Motor Controls
- FC** Flow Controls
- PC** Pressure Controls
- LE** Logic Elements
- DC** Directional Controls
- MV** Manual Valves
- SV** Solenoid Valves
- PV** Proportional Valves
- CE** Coils & Electronics
- BC** Bodies & Cavities
- TD** Technical Data

General Description

4-Way, 3 Position, Tandem Center Spool Valve.
For additional information see Technical Tips on pages SV1-SV6.

Features

- Designed to operate double acting cylinders, pilot circuits and bi-directional motors, etc.
- High flow capacity with reduced space requirements
- High pressure capability
- One piece cartridge housing ensures internal concentricity
- Coil: Waterproof, hermetically sealed, requires no O'Rings; Symmetrical coil can be reversed without affecting performance.
- Manual override available

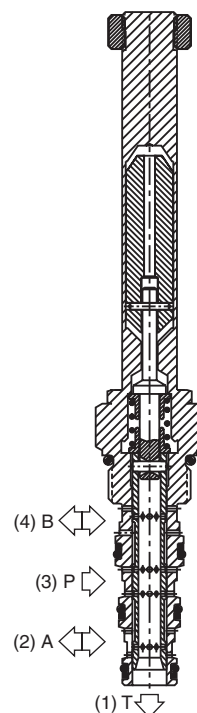
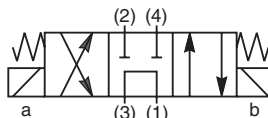

Specifications

Rated Flow (At 70 PSI ΔP)	13.3 LPM (3.5 GPM)
Maximum Inlet Pressure	350 Bar (5000 PSI)
Maximum Tank Pressure	210 Bar (3000 PSI)
Cartridge Material	All parts steel. All operating parts hardened steel.
Operating Temp. Range/Seals	-40°C to +93.3°C (Nitrile) (-40°F to +200°F) -31.7°C to +121.1°C (Fluorocarbon) (-25°F to +250°F)
Fluid Compatibility/Viscosity	Mineral-based or synthetic with lubricating properties at viscosities of 45 to 2000 SSU (6 to 420 cSt)
Filtration	ISO Code 16/13, SAE Class 4 or better
Approx. Weight	.18 kg (.40 lbs.)
Cavity	C08-4 (See BC Section for more details)

Performance Curves

Pressure Drop vs. Flow (Through cartridge only)

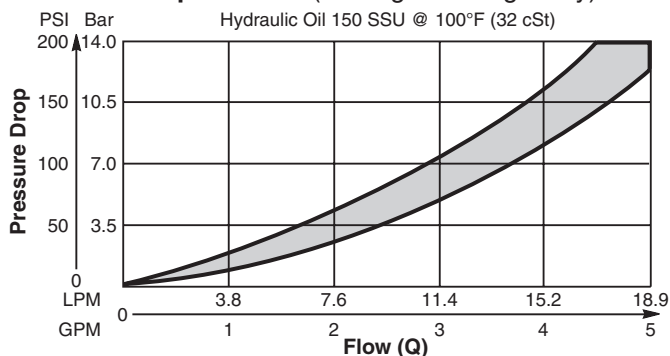

Operating Limits (Measured at 75% of Nominal Current)

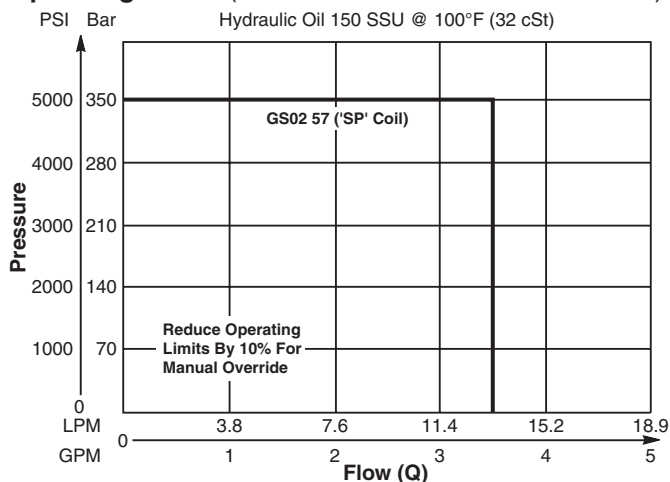

Dimensions Millimeters (Inches)

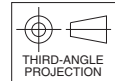
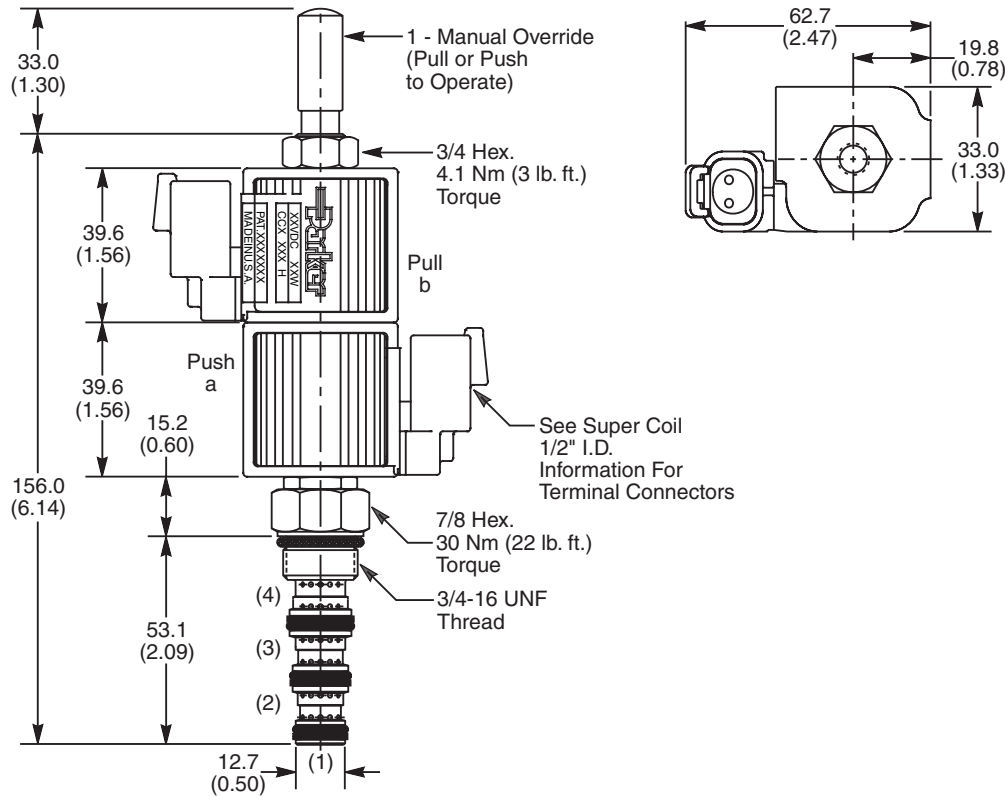

Ordering Information

GS02	57								
08 Size Solenoid Valve	Style	Override Option	Screen	Seals	Coil Type	Coil Voltage	Coil Termination	Body Material	Port Size

Code	Style
57	High Flow ("SP" Coil)

Code	Override Options
0	Not Required
1	Manual Override
2	Detented M.O.

Code	Screen
0	Not Available

Code	Seals / Kit No.
N	Nitrile / Buna-N (Std.) (SK30078N-1)
V	Fluorocarbon / (SK30078V-1)

Code	Coil Type
Omit	Without Coil
SP	Super Coil - 19 Watts

Code	Coil Voltage
Omit	Without Coil
D012	12 VDC
D024	24 VDC
A120	120 VAC, 60/50 Hz
A240	240 VAC, 60/50 Hz*

*22 Watts

Code	Coil Termination
Omit	Without Coil
C	Conduit With Leads
D	DIN Plug Face
A	Amp Jr. Timer*
S	Dual Spade*
L	Dual Lead Wire*
LS	Sealed Lead Wire*
H	Molded Deutsch*

See Super Coil 1/2" I.D.
*DC Only

Code	Body Material
Omit	Steel
A	Aluminum

Code	Port Size	Body Part No.
Omit	Cartridge Only	
6T	SAE-6	(B08-4-*6T)
6B	3/8" BSPG	(B08-4-*6B)

* Add "A" for aluminum, omit for steel.

- CV Check Valves
- SH Shuttle Valves
- LM Load/Motor Controls
- FC Flow Controls
- PC Pressure Controls
- LE Logic Elements
- DC Directional Controls
- MV Manual Valves
- SV Solenoid Valves
- PV Proportional Valves
- CE Coils & Electronics
- BC Bodies & Cavities
- TD Technical Data

Technical Information

- CV** Check Valves
- SH** Shuttle Valves
- LM** Load/Motor Controls
- FC** Flow Controls
- PC** Pressure Controls
- LE** Logic Elements
- DC** Directional Controls
- MV** Manual Valves
- SV** Solenoid Valves
- PV** Proportional Valves
- CE** Coils & Electronics
- BC** Bodies & Cavities
- TD** Technical Data

General Description

4-Way, 3 Position, Open Center Spool Valve.
For additional information see Technical Tips on pages SV1-SV6.

Features

- Designed to operate double acting cylinders, pilot circuits and bi-directional motors, etc.
- High flow capacity with reduced space requirements
- High pressure capability
- One piece cartridge housing ensures internal concentricity
- Coil: Waterproof, hermetically sealed, requires no O'Rings; Symmetrical coil can be reversed without affecting performance.
- Manual override available

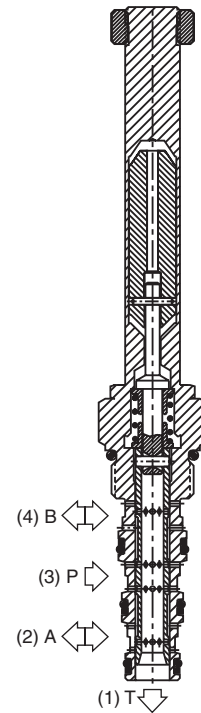
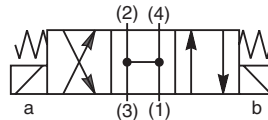

Specifications

Rated Flow (At 70 PSI ΔP)	13.3 LPM (3.5 GPM)
Maximum Inlet Pressure	350 Bar (5000 PSI)
Maximum Tank Pressure	210 Bar (3000 PSI)
Cartridge Material	All parts steel. All operating parts hardened steel.
Operating Temp. Range/Seals	-40°C to +93.3°C (Nitrile) (-40°F to +200°F) -31.7°C to +121.1°C (Fluorocarbon) (-25°F to +250°F)
Fluid Compatibility/Viscosity	Mineral-based or synthetic with lubricating properties at viscosities of 45 to 2000 SSU (6 to 420 cSt)
Filtration	ISO Code 16/13, SAE Class 4 or better
Approx. Weight	.18 kg (.40 lbs.)
Cavity	C08-4 (See BC Section for more details)

Performance Curves

Pressure Drop vs. Flow (Through cartridge only)

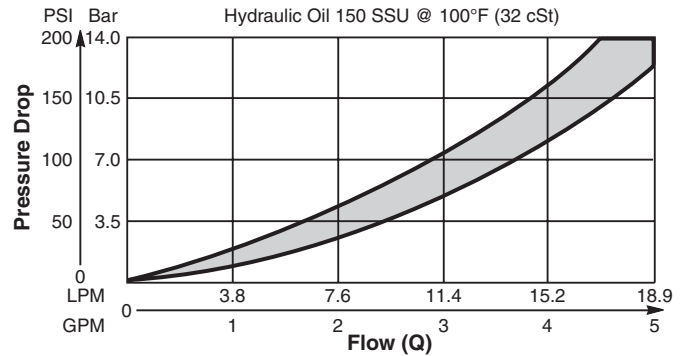

Operating Limits (Measured at 75% of Nominal Current)

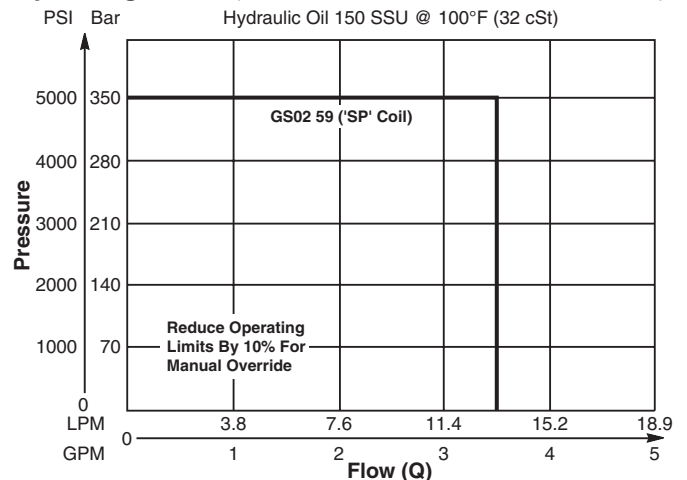

Dimensions Millimeters (Inches)

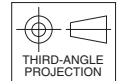
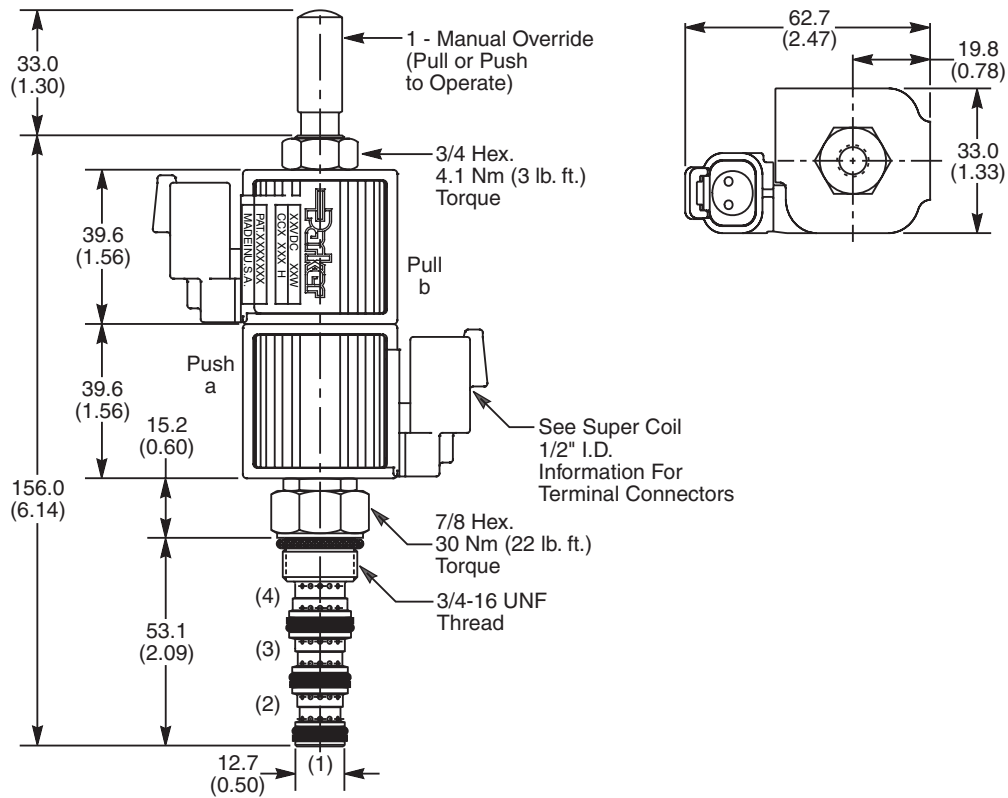

Ordering Information

GS02	59								
08 Size Solenoid Valve	Style	Override Option	Screen	Seals	Coil Type	Coil Voltage	Coil Termination	Body Material	Port Size

Code	Style
59	High Flow ("SP" Coil)

Code	Override Options
0	Not Required
1	Manual Override
2	Detented M.O.

Code	Screen
0	Not Available

Code	Seals / Kit No.
N	Nitrile / Buna-N (Std.) (SK30078N-1)
V	Fluorocarbon / (SK30078V-1)

Code	Coil Type
Omit	Without Coil
SP	Super Coil - 19 Watts

Code	Coil Voltage
Omit	Without Coil
D012	12 VDC
D024	24 VDC
A120	120 VAC, 60/50 Hz
A240	240 VAC, 60/50 Hz*

*22 Watts

Code	Coil Termination
Omit	Without Coil
C	Conduit With Leads
D	DIN Plug Face
A	Amp Jr. Timer*
S	Dual Spade*
L	Dual Lead Wire*
LS	Sealed Lead Wire*
H	Molded Deutsch*

See Super Coil 1/2" I.D.
*DC Only

Code	Body Material
Omit	Steel
A	Aluminum

Code	Port Size	Body Part No.
Omit	Cartridge Only	
6T	SAE-6	(B08-4-*6T)
6B	3/8" BSPG	(B08-4-*6B)

* Add "A" for aluminum, omit for steel.

- CV Check Valves
- SH Shuttle Valves
- LM Load/Motor Controls
- FC Flow Controls
- PC Pressure Controls
- LE Logic Elements
- DC Directional Controls
- MV Manual Valves
- SV Solenoid Valves
- PV Proportional Valves
- CE Coils & Electronics
- BC Bodies & Cavities
- TD Technical Data

Technical Information

- CV** Check Valves
- SH** Shuttle Valves
- LM** Load/Motor Controls
- FC** Flow Controls
- PC** Pressure Controls
- LE** Logic Elements
- DC** Directional Controls
- MV** Manual Valves
- SV** Solenoid Valves
- PV** Proportional Valves
- CE** Coils & Electronics
- BC** Bodies & Cavities
- TD** Technical Data

General Description

4-Way Spool Valves. For additional information see Technical Tips on pages SV1-SV6.



Features

- High flow capacity with reduced space requirements
- Standard valve bodies and common cavities
- Replaceable, one piece encapsulated coils with minimal amperage draw
- Manual overrides, seal variations and other options available
- Oil immersed armature solenoid, no dynamic seals
- Variety of coil terminations and voltages
- Polyurethane "D"-Ring

Specifications

Rated Flow	C2, C7, C9 18.8 LPM (5 GPM) C1, C4 26.5 LPM (7 GPM)
Maximum Inlet Pressure	250 Bar (3600 PSI)
Leakage at 150 SSU (32 cSt)	160 cc/min. (10 in ³ /min.)
Minimum Operating Voltage	85% of rated voltage at 20°C (72°F).
Response Time	40 - 150 ms
Cartridge Material	All parts steel. All operating parts hardened steel.
Operating Temp. Range/Seals	-45°C to +93.3°C ("D"-Ring) (-50°F to +200°F) -31.7°C to +121.1°C (Fluorocarbon) (-25°F to +250°F)
Fluid Compatibility/Viscosity	Mineral-based or synthetic with lubricating properties at viscosities of 45 to 2000 SSU (6 to 420 cSt)
Filtration	ISO Code 16/13, SAE Class 4 or better
Approx. Weight	.29 kg (.64 lbs.)
Cavity	C10-4
Form Tool	Rougher NFT10-4R Finisher NFT10-4F



DSL105C1

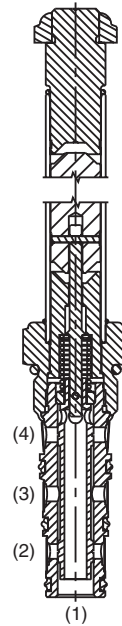
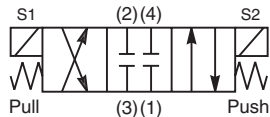

DSL105C1

Performance Curves

Pressure Drop vs. Flow (Through cartridge only)

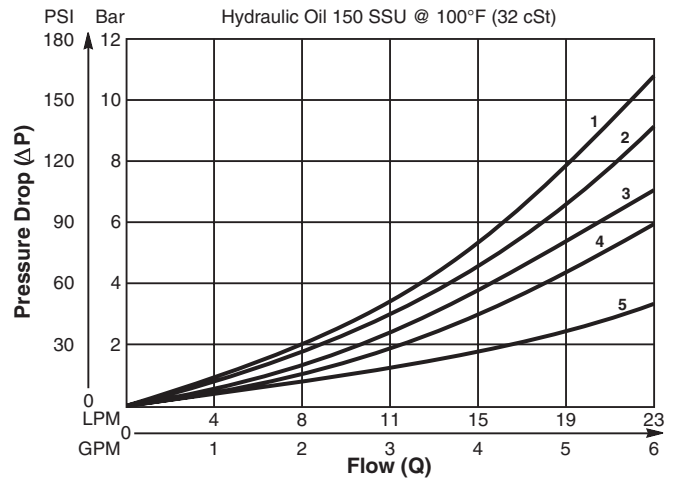

Shift Limit Characteristics (Min. Operating Voltage)

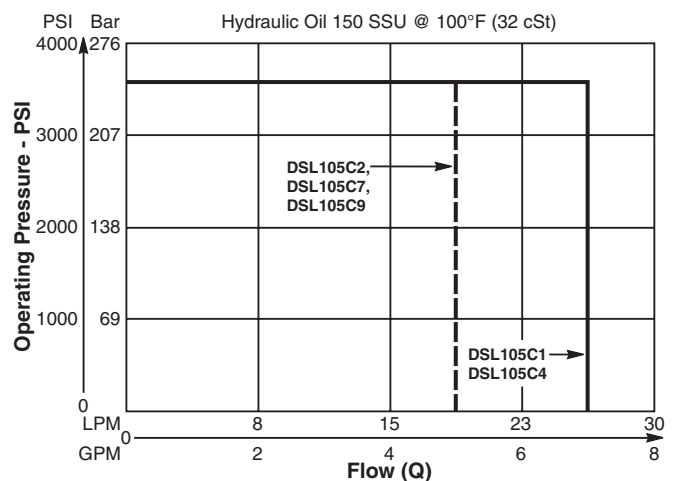

Curve Selection Chart

SPOOL CODE	SPOOL SHIFTED				SPOOL CENTERED		
	3 to 2	3 to 4	2 to 1	4 to 1	3 to 1	2 to 1	4 to 1
C1	2	2	4	4	—	—	—
C2	1	1	2	2	5	4	3
C4	2	2	5	5	—	4	4
C7	1	1	2	2	5	—	3
C9	1	1	2	2	5	—	—

Dimensions Millimeters (Inches)

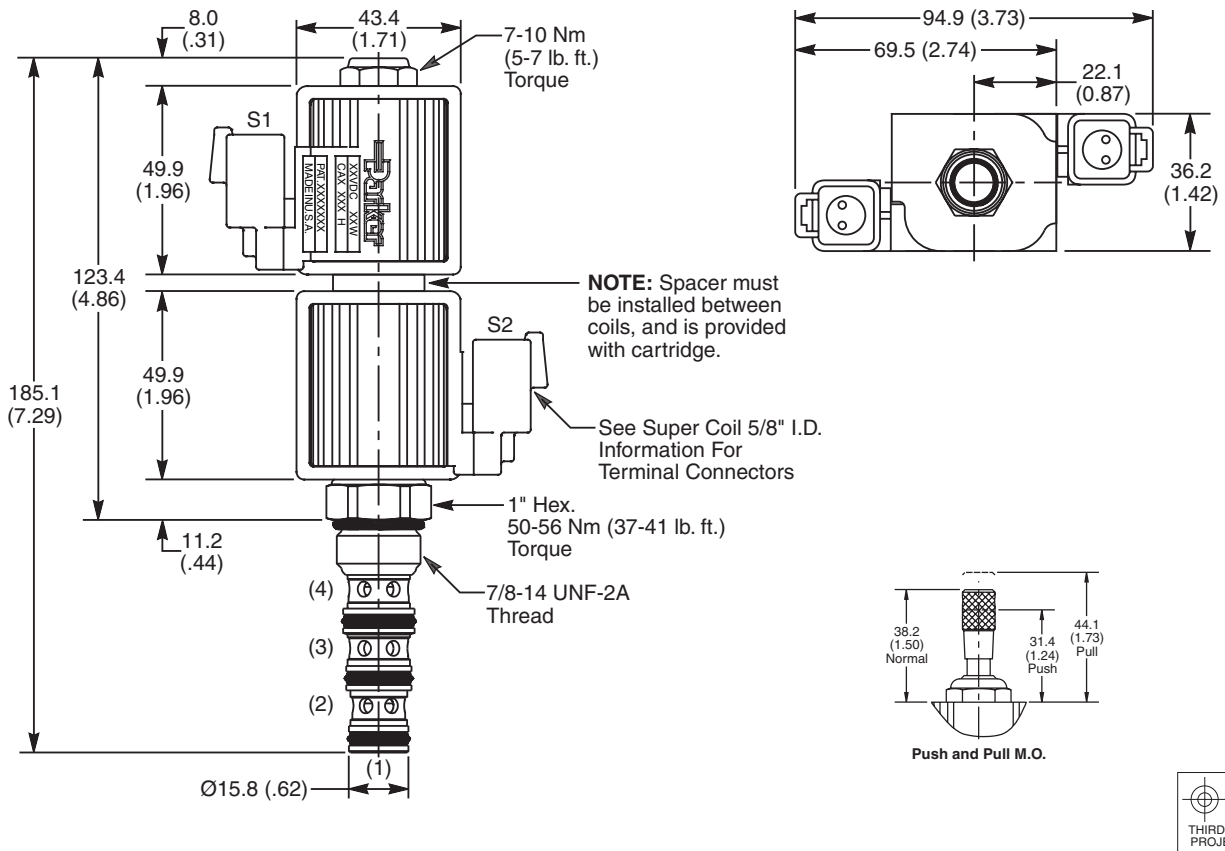

Ordering Information

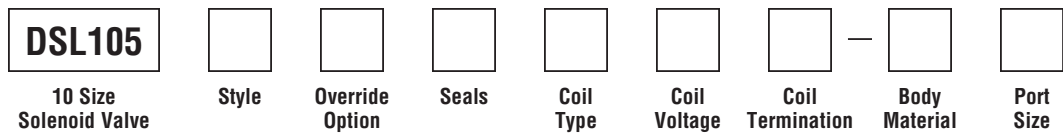

Code	Style
C1	
C2	
C4	
C7	
C9	

Code	Override Options
Omit	None
M	Push/Pull

Code	Seals / Kit. No.
Omit	"D"-Ring / (SK10-4)
N	Nitrile / (SK10-4N)
V	Fluorocarbon / (SK10-4V)

Code	Coil Type
Omit	Without Coil
SP*	Super Coil - 28 Watts

**Recommended*

Code	Coil Voltage
Omit	Without Coil
D012	12 VDC
D024	24 VDC
A120	120/110 VAC, 60/50 Hz
A240	240/220 VAC, 60/50 Hz

SP*	Coil Termination
Omit	Without Coil
C	Conduit With Leads
D	DIN Plug Face
A	Amp Jr. Timert†
S	Dual Spade†
L	Dual Lead Wire†
LS	Sealed Lead Wire†
H	Molded Deutsch†

**Recommended*
 †DC Only

Code	Body Material
Omit	Steel
A	Aluminum

Code	Port Size	Body Part No.
Omit	Cartridge Only	
6P	3/8" NTPF	(B10-4-*6P)
6T	SAE-6	(B10-4-*6T)
8T	SAE-8	(B10-4-*8T)
6B	3/8" BSPG	(B10-4-6B)†

** Add "A" for aluminum, omit for steel.
 † Steel bodies only*

- CV Check Valves
- SH Shuttle Valves
- LM Load/Motor Controls
- FC Flow Controls
- PC Pressure Controls
- LE Logic Elements
- DC Directional Controls
- MV Manual Valves
- SV Solenoid Valves
- PV Proportional Valves
- CE Coils & Electronics
- BC Bodies & Cavities
- TD Technical Data

Technical Information

- CV** Check Valves
- SH** Shuttle Valves
- LM** Load/Motor Controls
- FC** Flow Controls
- PC** Pressure Controls
- LE** Logic Elements
- DC** Directional Controls
- MV** Manual Valves
- SV** Solenoid Valves
- PV** Proportional Valves
- CE** Coils & Electronics
- BC** Bodies & Cavities
- TD** Technical Data

General Description

4-Way, 3 Position, Closed Center Spool Valve.
For additional information see Technical Tips on pages SV1-SV6.

Features

- Four way closed center valve designed to operate double acting cylinders and bi-directional motors, etc.
- One piece cartridge housing ensures internal concentricity
- Coil: Waterproof, hermetically sealed, requires no O'Rings; Symmetrical coil can be reversed without affecting performance.

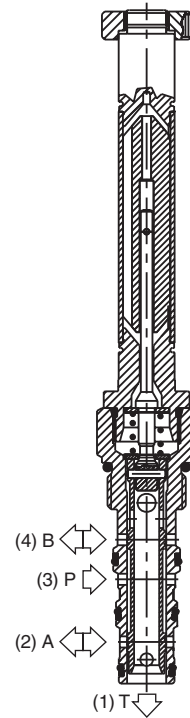
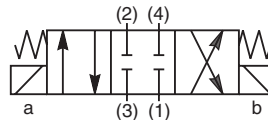

Specifications

Rated Flow (At 70 PSI ΔP)	42 LPM (11 GPM)
Maximum Inlet Pressure	350 Bar (5000 PSI)
Leakage at 150 SSU (32 cSt)	160 cc/min @ 210 Bar (3000 PSI)
Minimum Operating Voltage	85% of rated voltage at 20°C (72°F).
Response Time	Open 30-60 ms Close 20-40 ms
Cartridge Material	All parts steel. All operating parts hardened steel.
Operating Temp. Range/Seals	-40°C to +93.3°C (Nitrile) (-40°F to +200°F) -31.7°C to +121.1°C (Fluorocarbon) (-25°F to +250°F)
Fluid Compatibility/ Viscosity	Mineral-based or synthetic with lubricating properties at viscosities of 45 to 2000 SSU (6 to 420 cSt)
Filtration	ISO Code 16/13, SAE Class 4 or better
Approx. Weight	.26 kg (.58 lbs.)
Cavity	C10-4 (See BC Section for more details)

Performance Curves

Pressure Drop vs. Flow Energized - GS045250ND
(Through cartridge only)

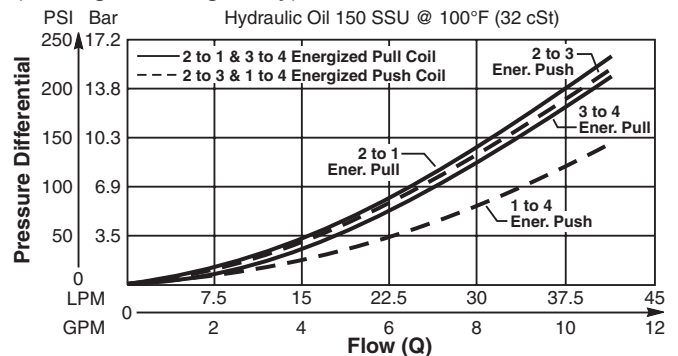

Operating Limits (Measured at 75% of Nominal Current)

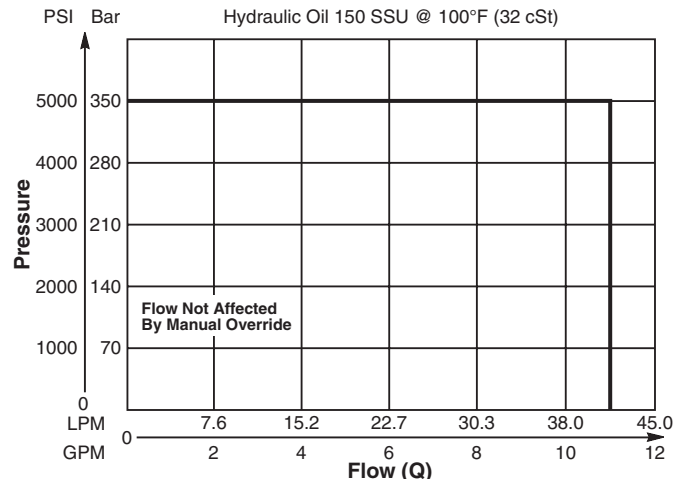

Technical Information

Dimensions Millimeters (Inches)

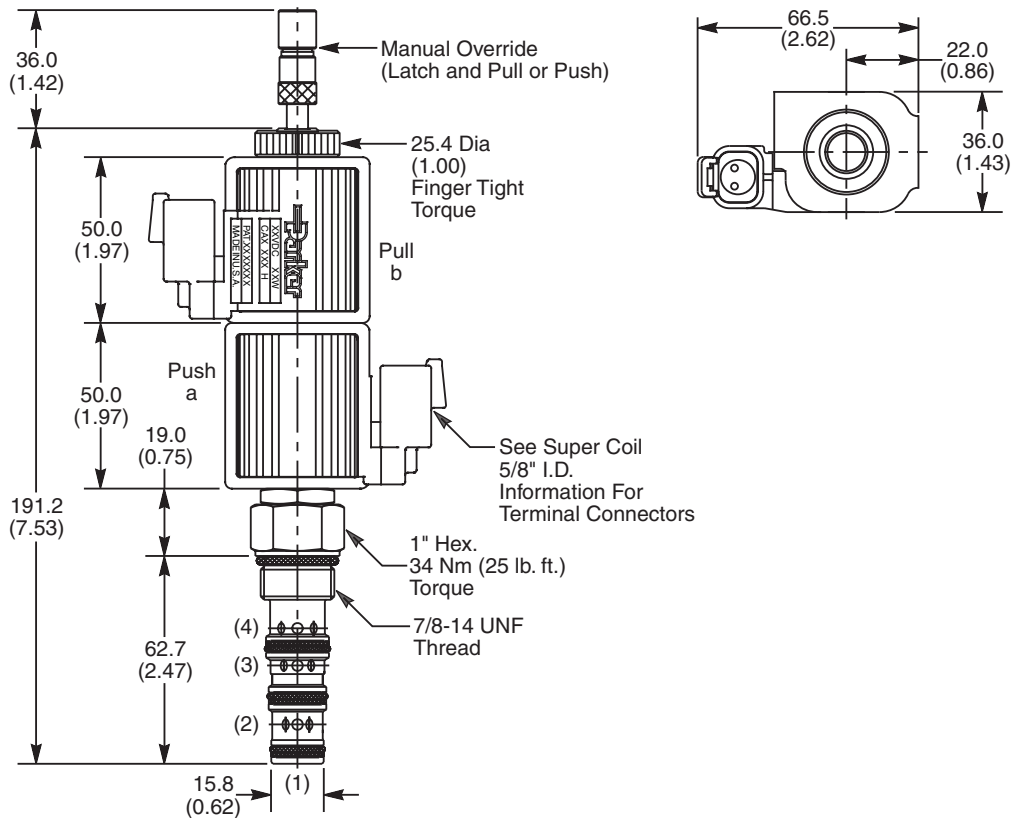

Ordering Information

GS04	52				D					
10 Size Solenoid Valve	Style	Override Option	Screen	Seals	Design Level	Coil Type	Coil Voltage	Coil Termination	Body Material	Port Size

Code	Style
52	High Flow and Pressure ('SP' Coil)

Code	Seals / Kit No.
N	Nitrile / Buna-N (Std.) (SK30506N-1)
V	Fluorocarbon / (SK30506V-1)

Code	Coil Termination
Omit	Without Coil
C	Conduit With Leads
D	DIN Plug Face
A	Amp Jr. Timer*
S	Dual Spade*
L	Dual Lead Wire*
LS	Sealed Lead Wire*
H	Molded Deutsch*

Code	Body Material
Omit	Steel
A	Aluminum

Code	Override Options
0	None
5	Standard - Latch Operated, Pull and Push (*40 nt/9 lbs.)

Code	Design Level
D	Includes Industry Common Cavity

See Super Coil 5/8" I.D.
*DC Only

Code	Port Size	Body Part No.
Omit	Cartridge Only	
8T	SAE-8	(B10-4-*8T)
8B	1/2" BSPG	(B10-4-*8B)

* Add "A" for aluminum, omit for steel.

Code	Screen
0	None (Contact factory for OEM requirements)

Code	Coil Type
Omit	Without Coil
SP	Super Coil - 28 Watts

Code	Coil Voltage
Omit	Without Coil
D012	12 VDC
D024	24 VDC
A120	120 VAC, 60/50 Hz
A240	240 VAC, 60/50 Hz*

*22 Watts

- CV Check Valves
- SH Shuttle Valves
- LM Load/Motor Controls
- FC Flow Controls
- PC Pressure Controls
- LE Logic Elements
- DC Directional Controls
- MV Manual Valves
- SV Solenoid Valves
- PV Proportional Valves
- CE Coils & Electronics
- BC Bodies & Cavities
- TD Technical Data

Technical Information

- CV** Check Valves
- SH** Shuttle Valves
- LM** Load/Motor Controls
- FC** Flow Controls
- PC** Pressure Controls
- LE** Logic Elements
- DC** Directional Controls
- MV** Manual Valves
- SV** Solenoid Valves
- PV** Proportional Valves
- CE** Coils & Electronics
- BC** Bodies & Cavities
- TD** Technical Data

General Description

4-Way, 3 Position, Floating Center Spool Valve.
For additional information see Technical Tips on pages SV1-SV6.

Features

- Four way floating center valve designed to operate double acting cylinders and bi-directional motors, etc.
- One piece cartridge housing ensures internal concentricity
- Coil: Waterproof, hermetically sealed, requires no O'Rings; Symmetrical coil can be reversed without affecting performance.

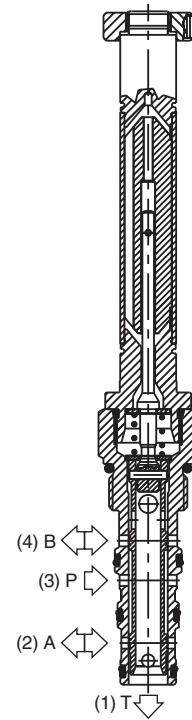
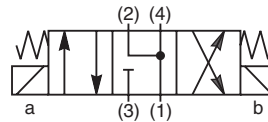

Specifications

Rated Flow (At 70 PSI ΔP)	42 LPM (11 GPM)
Maximum Inlet Pressure	350 Bar (5000 PSI)
Leakage at 150 SSU (32 cSt)	160 cc/min @ 210 Bar (3000 PSI)
Minimum Operating Voltage	85% of rated voltage at 20°C (72°F).
Response Time	Open 30-60 ms Close 20-40 ms
Cartridge Material	All parts steel. All operating parts hardened steel.
Operating Temp. Range/Seals	-40°C to +93.3°C (Nitrile) (-40°F to +200°F) -31.7°C to +121.1°C (Fluorocarbon) (-25°F to +250°F)
Fluid Compatibility/ Viscosity	Mineral-based or synthetic with lubricating properties at viscosities of 45 to 2000 SSU (6 to 420 cSt)
Filtration	ISO Code 16/13, SAE Class 4 or better
Approx. Weight	.26 kg (.58 lbs.)
Cavity	C10-4 (See BC Section for more details)

Performance Curves

Pressure Drop vs. Flow Energized - GS045450ND
(Through cartridge only)

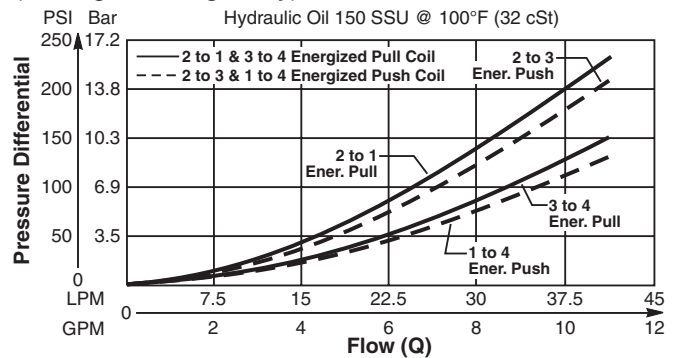

Operating Limits (Measured at 75% of Nominal Current)

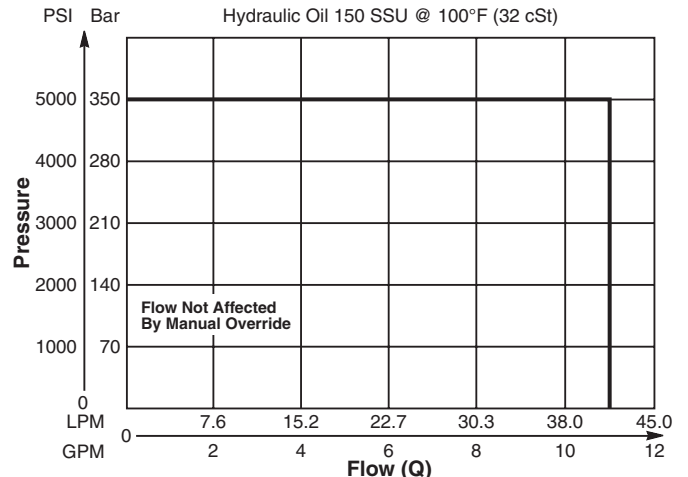

Technical Information

Dimensions Millimeters (Inches)

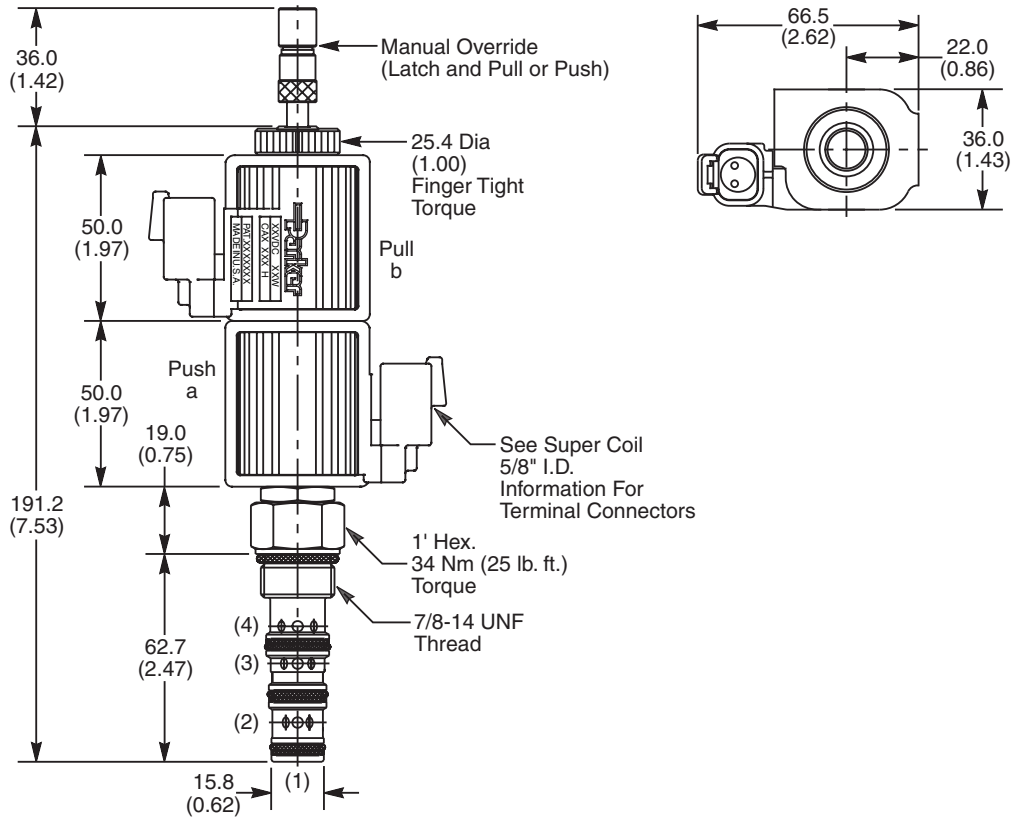

Ordering Information

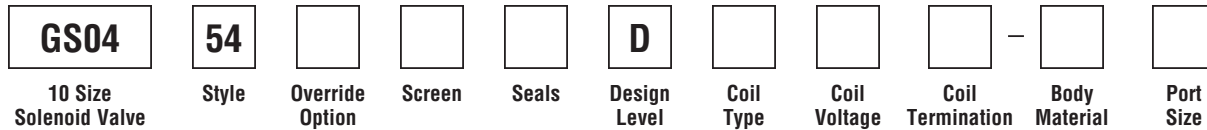

Code	Style
54	High Flow and Pressure ('SP' Coil)

Code	Seals / Kit No.
N	Nitrile / Buna-N (Std.) (SK30506N-1)
V	Fluorocarbon / (SK30506V-1)

Code	Coil Termination
Omit	Without Coil
C	Conduit With Leads
D	DIN Plug Face
A	Amp Jr. Timer*
S	Dual Spade*
L	Dual Lead Wire*
LS	Sealed Lead Wire*
H	Molded Deutsch*

Code	Body Material
Omit	Steel
A	Aluminum

Code	Override Options
0	None
5	Standard - Latch Operated, Pull and Push (*40 nt/9 lbs.)

Code	Design Level
D	Includes Industry Common Cavity

Code	Port Size	Body Part No.
Omit	Cartridge Only	
8T	SAE-8	(B10-4-*8T)
8B	1/2" BSPG	(B10-4-*8B)

*Force to push at 210 Bar (3000 PSI). Less to Pull.

Code	Screen
0	None (Contact factory for OEM requirements)

Code	Coil Type
Omit	Without Coil
SP	Super Coil - 28 Watts

See Super Coil 5/8" I.D.
*DC Only

Code	Coil Voltage
Omit	Without Coil
D012	12 VDC
D024	24 VDC
A120	120 VAC, 60/50 Hz
A240	240 VAC, 60/50 Hz*

*22 Watts

* Add "A" for aluminum, omit for steel.

- CV Check Valves
- SH Shuttle Valves
- LM Load/Motor Controls
- FC Flow Controls
- PC Pressure Controls
- LE Logic Elements
- DC Directional Controls
- MV Manual Valves
- SV Solenoid Valves
- PV Proportional Valves
- CE Coils & Electronics
- BC Bodies & Cavities
- TD Technical Data

Technical Information

- CV** Check Valves
- SH** Shuttle Valves
- LM** Load/Motor Controls
- FC** Flow Controls
- PC** Pressure Controls
- LE** Logic Elements
- DC** Directional Controls
- MV** Manual Valves
- SV** Solenoid Valves
- PV** Proportional Valves
- CE** Coils & Electronics
- BC** Bodies & Cavities
- TD** Technical Data

General Description

4-Way, 3 Position, Tandem Center Spool Valve.
For additional information see Technical Tips on pages SV1-SV6.

Features

- Four way tandem center valve designed to operate double acting cylinders and bi-directional motors, etc.
- One piece cartridge housing ensures internal concentricity
- Coil: Waterproof, hermetically sealed, requires no O'Rings; Symmetrical coil can be reversed without affecting performance.

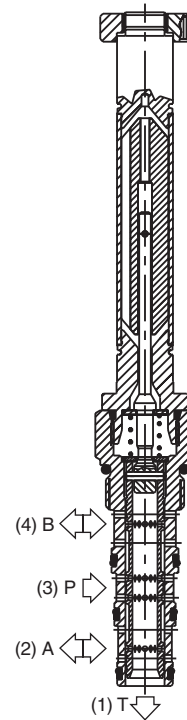
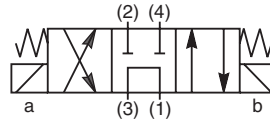

Specifications

Rated Flow (At 70 PSI ΔP)	42 LPM (11 GPM)
Maximum Inlet Pressure	350 Bar (5000 PSI)
Leakage at 150 SSU (32 cSt)	160 cc/min @ 210 Bar (3000 PSI)
Minimum Operating Voltage	85% of rated voltage at 20°C (72°F).
Response Time	Open 30-60 ms Close 20-40 ms
Cartridge Material	All parts steel. All operating parts hardened steel.
Operating Temp. Range/Seals	-40°C to +93.3°C (Nitrile) (-40°F to +200°F) -31.7°C to +121.1°C (Fluorocarbon) (-25°F to +250°F)
Fluid Compatibility/ Viscosity	Mineral-based or synthetic with lubricating properties at viscosities of 45 to 2000 SSU (6 to 420 cSt)
Filtration	ISO Code 16/13, SAE Class 4 or better
Approx. Weight	.26 kg (.58 lbs.)
Cavity	C10-4 (See BC Section for more details)

Performance Curves

Pressure Drop vs. Flow (Through cartridge only)

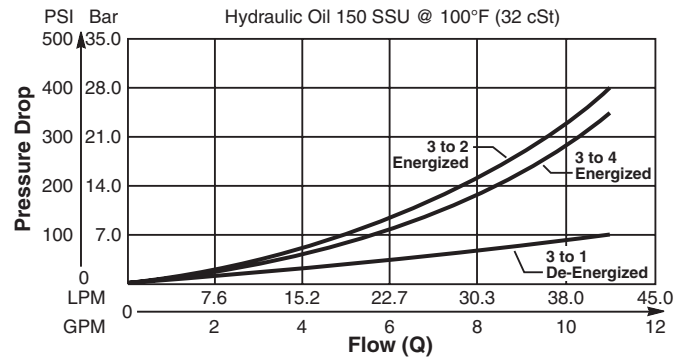

Operating Limits (Measured at 75% of Nominal Current)

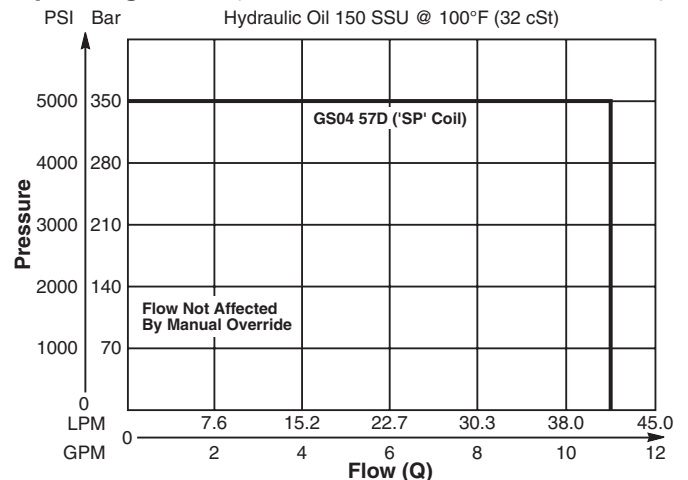

Technical Information

Dimensions Millimeters (Inches)

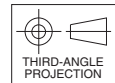
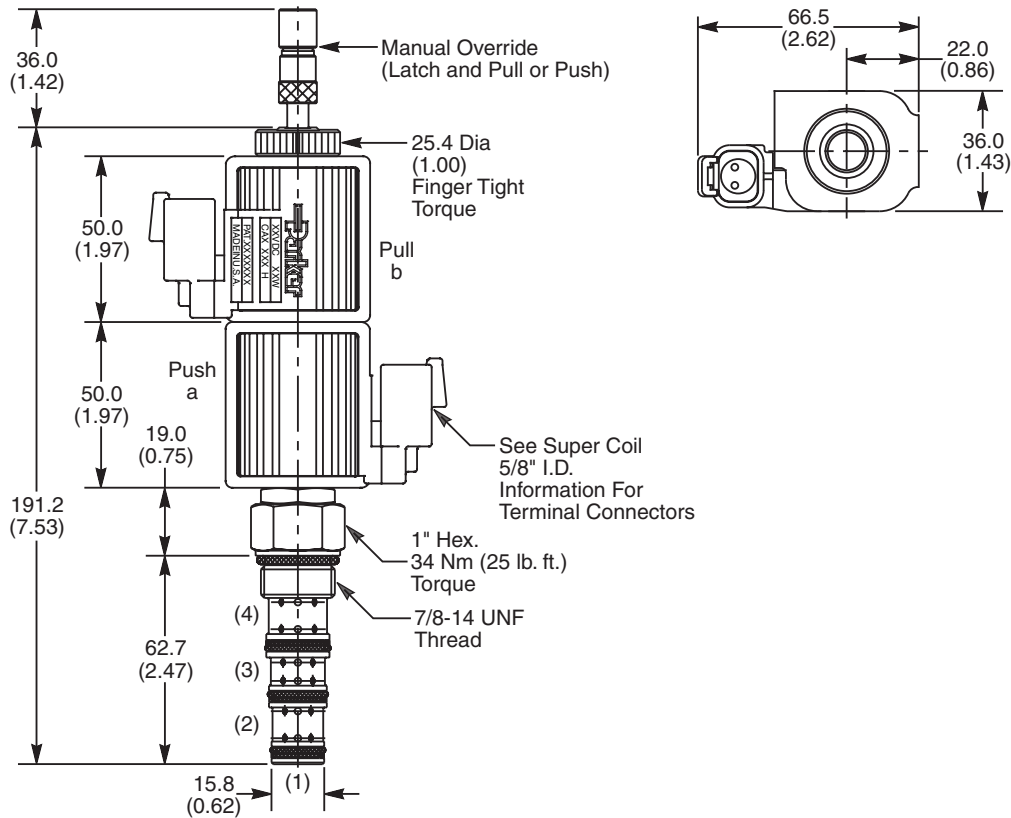

Ordering Information

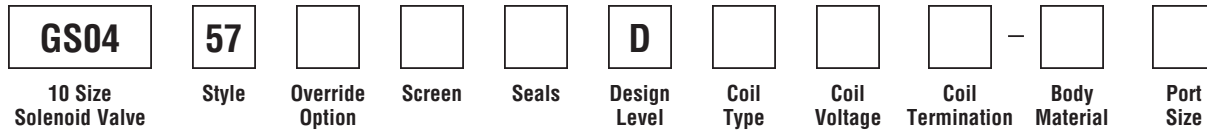

Code	Style
57	High Flow and Pressure ('SP' Coil)

Code	Seals / Kit No.
N	Nitrile / Buna-N (Std.) (SK30506N-1)
V	Fluorocarbon / (SK30506V-1)

Code	Coil Termination
Omit	Without Coil
C	Conduit With Leads
D	DIN Plug Face
A	Amp Jr. Timer*
S	Dual Spade*
L	Dual Lead Wire*
LS	Sealed Lead Wire*
H	Molded Deutsch*

Code	Body Material
Omit	Steel
A	Aluminum

Code	Override Options
0	None
5	Standard - Latch Operated, Pull and Push (*40 nt/9 lbs.)

Code	Design Level
D	Includes Industry Common Cavity

Code	Port Size	Body Part No.
Omit	Cartridge Only	
8T	SAE-8	(B10-4-*8T)
8B	1/2" BSPG	(B10-4-*8B)

*Force to push at 210 Bar (3000 PSI). Less to Pull.

Code	Screen
0	None (Contact factory for OEM requirements)

Code	Coil Type
Omit	Without Coil
SP	Super Coil - 28 Watts

See Super Coil 5/8" I.D.
*DC Only

Code	Coil Voltage
Omit	Without Coil
D012	12 VDC
D024	24 VDC
A120	120 VAC, 60/50 Hz
A240	240 VAC, 60/50 Hz*

*22 Watts

* Add "A" for aluminum, omit for steel.

- CV Check Valves
- SH Shuttle Valves
- LM Load/Motor Controls
- FC Flow Controls
- PC Pressure Controls
- LE Logic Elements
- DC Directional Controls
- MV Manual Valves
- SV Solenoid Valves
- PV Proportional Valves
- CE Coils & Electronics
- BC Bodies & Cavities
- TD Technical Data

Technical Information

- CV** Check Valves
- SH** Shuttle Valves
- LM** Load/Motor Controls
- FC** Flow Controls
- PC** Pressure Controls
- LE** Logic Elements
- DC** Directional Controls
- MV** Manual Valves
- SV** Solenoid Valves
- PV** Proportional Valves
- CE** Coils & Electronics
- BC** Bodies & Cavities
- TD** Technical Data

General Description

4-Way, 3 Position, Open Center Spool Valve.
For additional information see Technical Tips on pages SV1-SV6.

Features

- Four way open center valve designed to operate double acting cylinders and bi-directional motors, etc.
- One piece cartridge housing ensures internal concentricity
- Coil: Waterproof, hermetically sealed, requires no O'Rings; Symmetrical coil can be reversed without affecting performance.

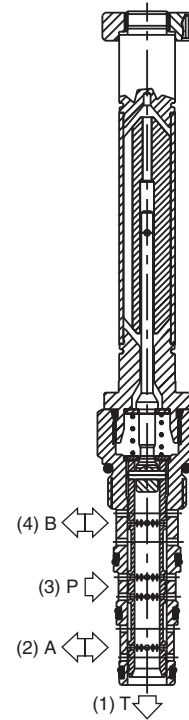
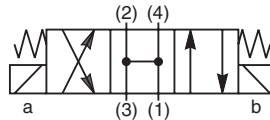

Specifications

Rated Flow (At 70 PSI ΔP)	42 LPM (11 GPM)
Maximum Inlet Pressure	350 Bar (5000 PSI)
Leakage at 150 SSU (32 cSt)	160 cc/min @ 210 Bar (3000 PSI)
Minimum Operating Voltage	85% of rated voltage at 20°C (72°F).
Response Time	Open 30-60 ms Close 20-40 ms
Cartridge Material	All parts steel. All operating parts hardened steel.
Operating Temp. Range/Seals	-40°C to +93.3°C (Nitrile) (-40°F to +200°F) -31.7°C to +121.1°C (Fluorocarbon) (-25°F to +250°F)
Fluid Compatibility/ Viscosity	Mineral-based or synthetic with lubricating properties at viscosities of 45 to 2000 SSU (6 to 420 cSt)
Filtration	ISO Code 16/13, SAE Class 4 or better
Approx. Weight	.26 kg (.58 lbs.)
Cavity	C10-4 (See BC Section for more details)

Performance Curves

Pressure Drop vs. Flow (Through cartridge only)

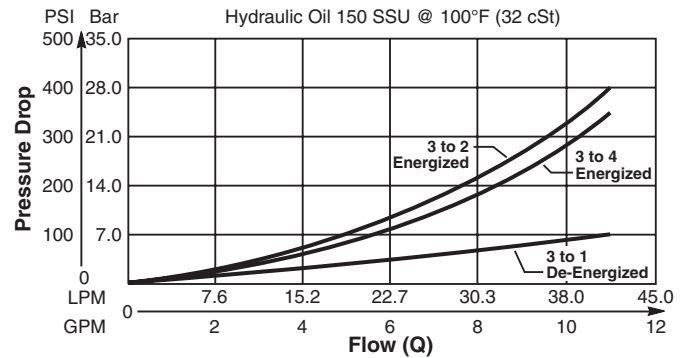

Operating Limits (Measured at 75% of Nominal Current)

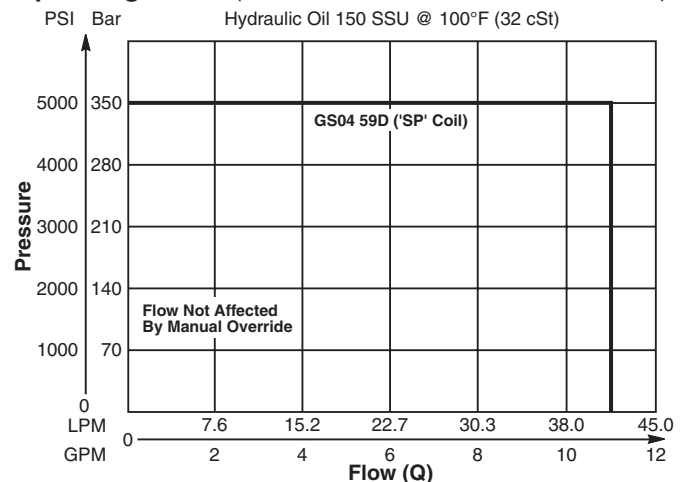

Technical Information

Dimensions Millimeters (Inches)

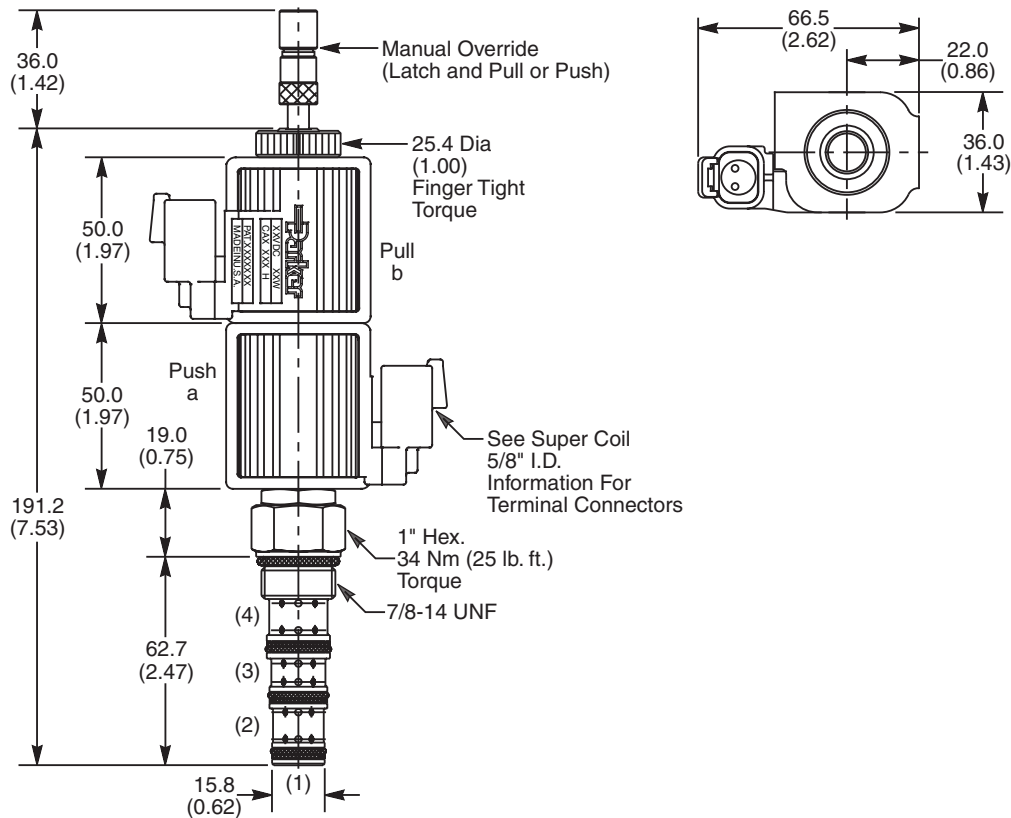

Ordering Information

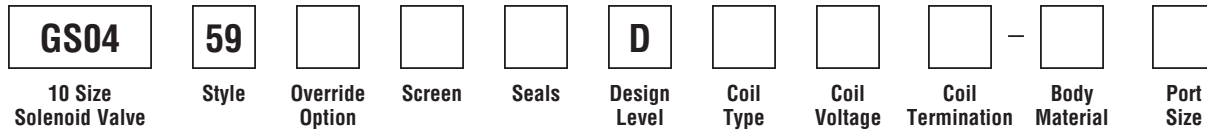

Code	Style
59	High Flow and Pressure ('SP' Coil)

Code	Seals / Kit No.
N	Nitrile / Buna-N (Std.) (SK30506N-1)
V	Fluorocarbon / (SK30506V-1)

Code	Coil Termination
Omit	Without Coil
C	Conduit With Leads
D	DIN Plug Face
A	Amp Jr. Timer*
S	Dual Spade*
L	Dual Lead Wire*
LS	Sealed Lead Wire*
H	Molded Deutsch*

Code	Body Material
Omit	Steel
A	Aluminum

Code	Override Options
0	None
5	Standard - Latch Operated, Pull and Push (*40 nt/9 lbs.)

Code	Design Level
D	Includes Industry Common Cavity

Code	Port Size	Body Part No.
Omit	Cartridge Only	
8T	SAE-8	(B10-4-*8T)
8B	1/2" BSPG	(B10-4-*8B)

*Force to push at 210 Bar (3000 PSI). Less to Pull.

Code	Screen
0	None (Contact factory for OEM requirements)

Code	Coil Type
Omit	Without Coil
SP	Super Coil - 28 Watts

See Super Coil 5/8" I.D.
*DC Only

Code	Coil Voltage
Omit	Without Coil
D012	12 VDC
D024	24 VDC
A120	120 VAC, 60/50 Hz
A240	240 VAC, 60/50 Hz*

*22 Watts



- CV Check Valves
- SH Shuttle Valves
- LM Load/Motor Controls
- FC Flow Controls
- PC Pressure Controls
- LE Logic Elements
- DC Directional Controls
- MV Manual Valves
- SV Solenoid Valves
- PV Proportional Valves
- CE Coils & Electronics
- BC Bodies & Cavities
- TD Technical Data

Technical Information

- CV** Check Valves
- SH** Shuttle Valves
- LM** Load/Motor Controls
- FC** Flow Controls
- PC** Pressure Controls
- LE** Logic Elements
- DC** Directional Controls
- MV** Manual Valves
- SV** Solenoid Valves
- PV** Proportional Valves
- CE** Coils & Electronics
- BC** Bodies & Cavities
- TD** Technical Data

General Description

4-Way, 3 Position, Closed Center Spool Valve.
For additional information see Technical Tips on pages SV1-SV6.

Features

- Four way closed center valve designed to operate double acting cylinders and bi-directional motors, etc.
- One piece cartridge housing ensures internal concentricity
- Coil: Waterproof, hermetically sealed, requires no O’Rings; Symmetrical coil can be reversed without affecting performance.
- All external parts zinc plated

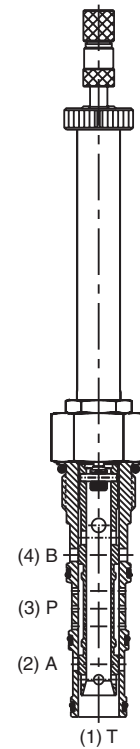
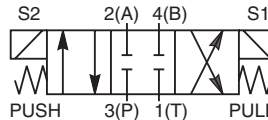
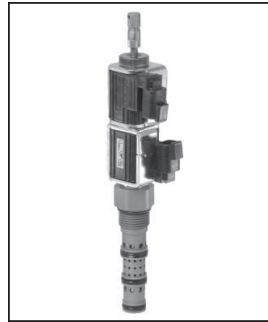

Specifications

Rated Flow (At 70 PSI ΔP)	57 LPM (15 GPM)	
Maximum Inlet Pressure	350 Bar (5000 PSI)	
Leakage at 150 SSU (32 cSt)	160 cc/min @ 210 Bar (3000 PSI)	
Minimum Operating Voltage	75% of rated voltage at 20°C (72°F).	
Response Time	Energized	30-60 ms
	De-Energized	20-40 ms
Cartridge Material	All parts steel. All operating parts hardened steel.	
Operating Temp. Range/Seals	-45°C to +93.3°C (Nitrile) (-50°F to +200°F) -31.7°C to +121.1°C (Fluorocarbon) (-25°F to +250°F)	
Fluid Compatibility/ Viscosity	Mineral-based or synthetic with lubricating properties at viscosities of 45 to 2000 SSU (6 to 420 cSt)	
Filtration	ISO Code 16/13, SAE Class 4 or better	
Approx. Weight	.45 kg (1.0 lbs.)	
Cavity	C12-4L (See BC Section for more details)	

Performance Curves
Pressure Drop vs. Flow
(Through cartridge only)

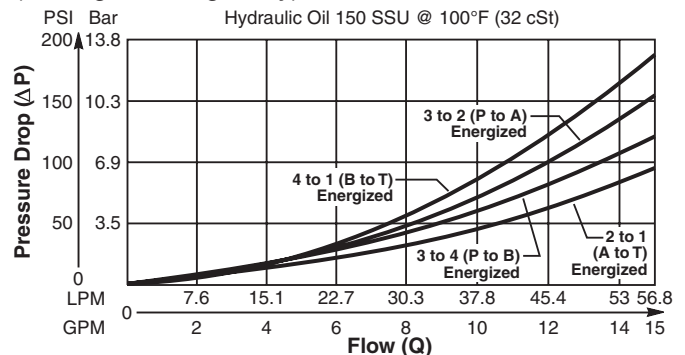

Shift Limit Characteristics (Min. Operating Voltage)

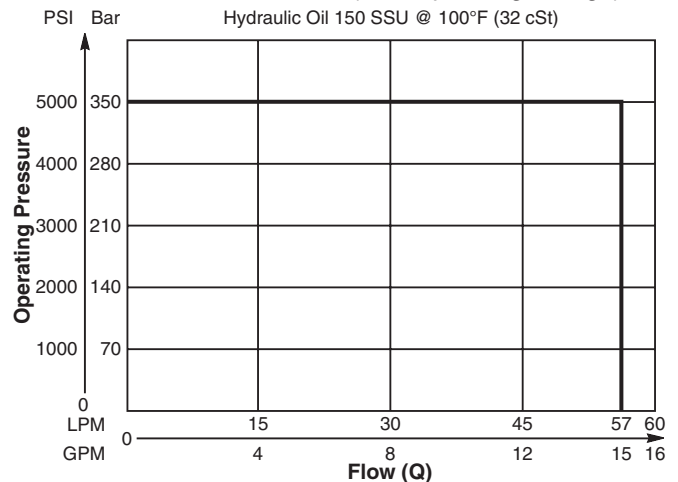

Technical Information

Dimensions Millimeters (Inches)

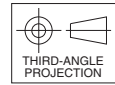
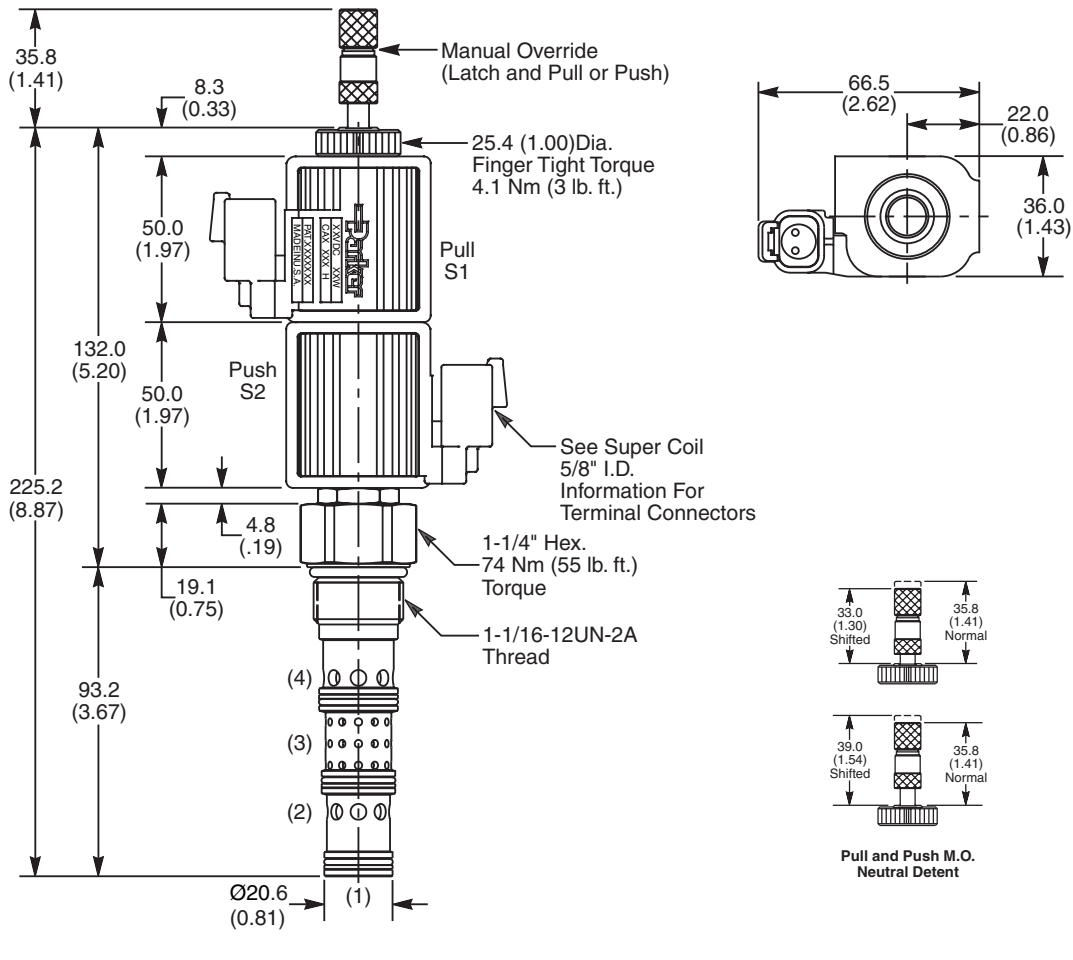

Ordering Information

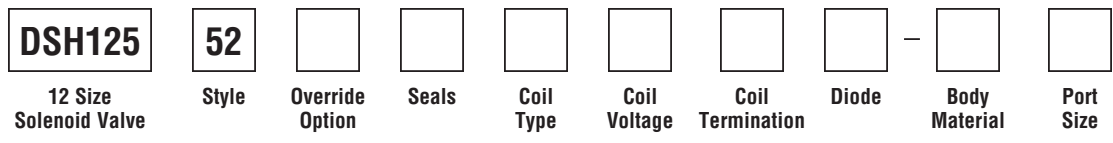

Code	Style
52	High Flow ('SP' Coil)

Code	Coil Type
Omit	Without Coil
SP	Super Coil - 28 Watts

Code	Coil Termination
Omit	Without Coil
C	Conduit With Leads
D	DIN Plug Face
S	Dual Spade*
L	Dual Lead Wire*
LS	Sealed Lead Wire*
H	Molded Deutsch*

Code	Body Material
Omit	Steel
A	Aluminum

Code	Override Options
Omit	None (Consult Factory)
DN	Latch Operated**

Code	Coil Voltage
Omit	Without Coil
D012	12 VDC
D024	24 VDC
A120	120 VAC, 60/50 Hz
A240	240 VAC, 60/50 Hz*

See Super Coil 5/8" I.D.
*DC Only

Code	Port Size	Body Part No.
Omit	Cartridge Only	
12T	SAE-12	(B12-4L-*12T)

* Add "A" for aluminum, omit for steel.

Code	Seals / Kit No.
N	Nitrile / Buna-N (Std.) (SK12-4LN)
V	Fluorocarbon / (SK12-4LV)

**22 Watts

Code	Diode
Omit	None
R	Diode



- CV
Check Valves
- SH
Shuttle Valves
- LM
Load/Motor Controls
- FC
Flow Controls
- PC
Pressure Controls
- LE
Logic Elements
- DC
Directional Controls
- MV
Manual Valves
- SV
Solenoid Valves
- PV
Proportional Valves
- CE
Coils & Electronics
- BC
Bodies & Cavities
- TD
Technical Data

Technical Information

- CV** Check Valves
- SH** Shuttle Valves
- LM** Load/Motor Controls
- FC** Flow Controls
- PC** Pressure Controls
- LE** Logic Elements
- DC** Directional Controls
- MV** Manual Valves
- SV** Solenoid Valves
- PV** Proportional Valves
- CE** Coils & Electronics
- BC** Bodies & Cavities
- TD** Technical Data

General Description

4-Way, 3 Position, Floating Center Spool Valve.
For additional information see Technical Tips on pages SV1-SV6.

Features

- Four way floating center valve designed to operate double acting cylinders and bi-directional motors, etc.
- One piece cartridge housing ensures internal concentricity
- Coil: Waterproof, hermetically sealed, requires no O'Rings; Symmetrical coil can be reversed without affecting performance.
- All external parts zinc plated

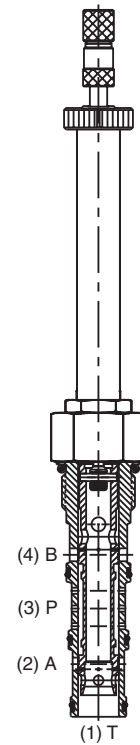
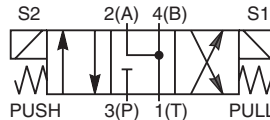
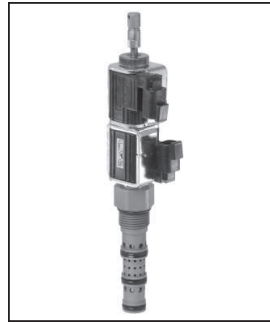

Specifications

Rated Flow (At 70 PSI ΔP)	57 LPM (15 GPM)	
Maximum Inlet Pressure	350 Bar (5000 PSI)	
Leakage at 150 SSU (32 cSt)	160 cc/min @ 210 Bar (3000 PSI)	
Minimum Operating Voltage	75% of rated voltage at 20°C (72°F).	
Response Time	Energized	30-60 ms
	De-Energized	20-40 ms
Cartridge Material	All parts steel. All operating parts hardened steel.	
Operating Temp. Range/Seals	-45°C to +93.3°C (Nitrile) (-50°F to +200°F) -31.7°C to +121.1°C (Fluorocarbon) (-25°F to +250°F)	
Fluid Compatibility/Viscosity	Mineral-based or synthetic with lubricating properties at viscosities of 45 to 2000 SSU (6 to 420 cSt)	
Filtration	ISO Code 16/13, SAE Class 4 or better	
Approx. Weight	.45 kg (1.0 lbs.)	
Cavity	C12-4L (See BC Section for more details)	

Performance Curves
Pressure Drop vs. Flow
(Through cartridge only)

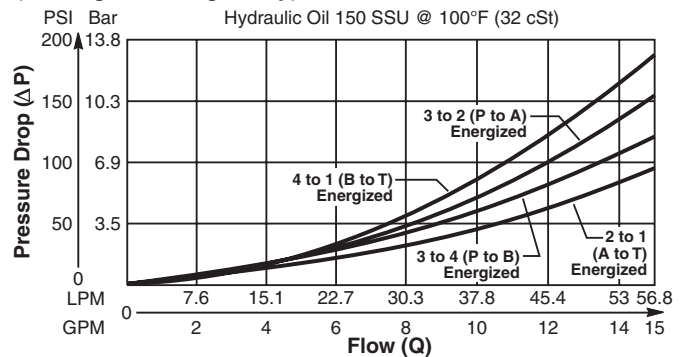

Shift Limit Characteristics (Min. Operating Voltage)

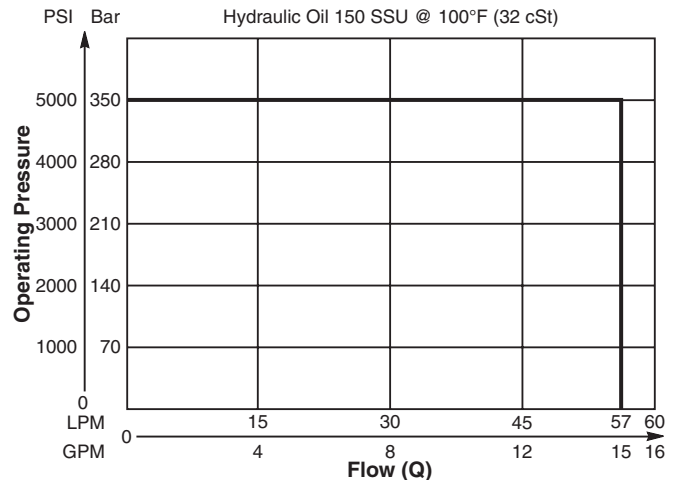

Technical Information

Dimensions Millimeters (Inches)

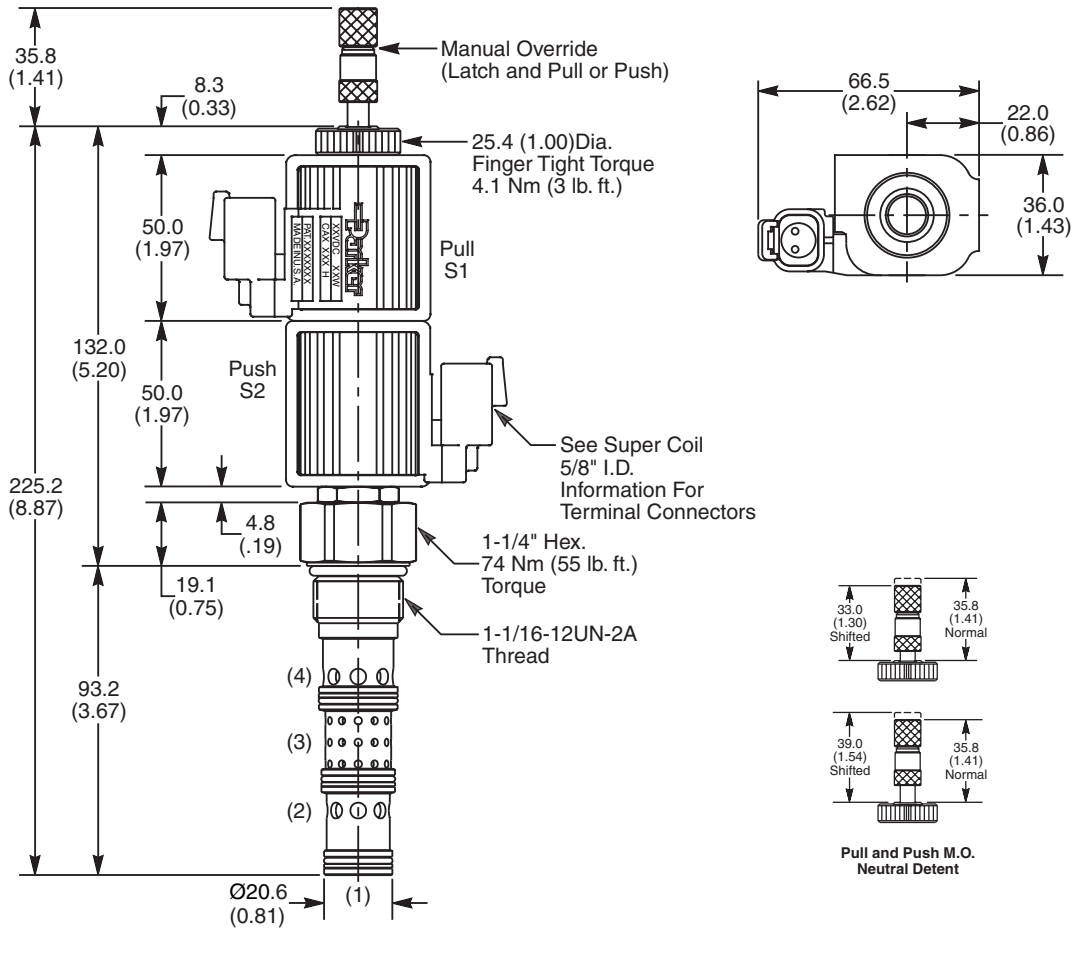

Ordering Information

DSH125	54								
12 Size Solenoid Valve	Style	Override Option	Seals	Coil Type	Coil Voltage	Coil Termination	Diode	Body Material	Port Size

Code	Style
54	High Flow ('SP' Coil)

Code	Coil Type
Omit	Without Coil
SP	Super Coil - 28 Watts

Code	Coil Termination
Omit	Without Coil
C	Conduit With Leads
D	DIN Plug Face
S	Dual Spade*
L	Dual Lead Wire*
LS	Sealed Lead Wire*
H	Molded Deutsch*

See Super Coil 5/8" I.D.
*DC Only

Code	Body Material
Omit	Steel
A	Aluminum

Code	Override Options
Omit	None (Consult Factory)
DN	Latch Operated**

Code	Coil Voltage
Omit	Without Coil
D012	12 VDC
D024	24 VDC
A120	120 VAC, 60/50 Hz
A240	240 VAC, 60/50 Hz*

**22 Watts

Code	Port Size	Body Part No.
Omit	Cartridge Only	
12T	SAE-12	(B12-4L-*12T)

**40 nt/9 lbs.

Code	Seals / Kit No.
N	Nitrile / Buna-N (Std.) (SK12-4LN)
V	Fluorocarbon / (SK12-4LV)

Code	Diode
Omit	None
R	Diode

* Add "A" for aluminum, omit for steel.



- CV Check Valves
- SH Shuttle Valves
- LM Load/Motor Controls
- FC Flow Controls
- PC Pressure Controls
- LE Logic Elements
- DC Directional Controls
- MV Manual Valves
- SV Solenoid Valves
- PV Proportional Valves
- CE Coils & Electronics
- BC Bodies & Cavities
- TD Technical Data

Technical Information

- CV** Check Valves
- SH** Shuttle Valves
- LM** Load/Motor Controls
- FC** Flow Controls
- PC** Pressure Controls
- LE** Logic Elements
- DC** Directional Controls
- MV** Manual Valves
- SV** Solenoid Valves
- PV** Proportional Valves
- CE** Coils & Electronics
- BC** Bodies & Cavities
- TD** Technical Data

General Description

4-Way, 3 Position, Tandem Center Spool Valve.
For additional information see Technical Tips on pages SV1-SV6.

Features

- Four way tandem center valve designed to operate double acting cylinders and bi-directional motors, etc.
- One piece cartridge housing ensures internal concentricity
- Coil: Waterproof, hermetically sealed, requires no O’Rings; Symmetrical coil can be reversed without affecting performance.
- All external parts zinc plated

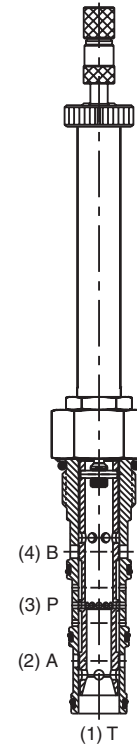
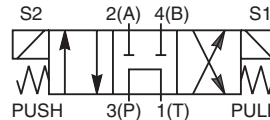
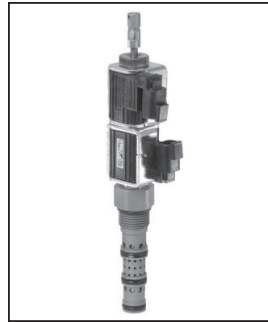

Specifications

Rated Flow (At 70 PSI ΔP)	57 LPM (15 GPM)	
Maximum Inlet Pressure	350 Bar (5000 PSI)	
Leakage at 150 SSU (32 cSt)	160 cc/min @ 210 Bar (3000 PSI)	
Minimum Operating Voltage	75% of rated voltage at 20°C (72°F).	
Response Time	Energized	30-60 ms
	De-Energized	20-40 ms
Cartridge Material	All parts steel. All operating parts hardened steel.	
Operating Temp. Range/Seals	-45°C to +93.3°C (Nitrile) (-50°F to +200°F) -31.7°C to +121.1°C (Fluorocarbon) (-25°F to +250°F)	
Fluid Compatibility/ Viscosity	Mineral-based or synthetic with lubricating properties at viscosities of 45 to 2000 SSU (6 to 420 cSt)	
Filtration	ISO Code 16/13, SAE Class 4 or better	
Approx. Weight	.45 kg (1.0 lbs.)	
Cavity	C12-4L (See BC Section for more details)	

Performance Curves

Pressure Drop vs. Flow (Through cartridge only)

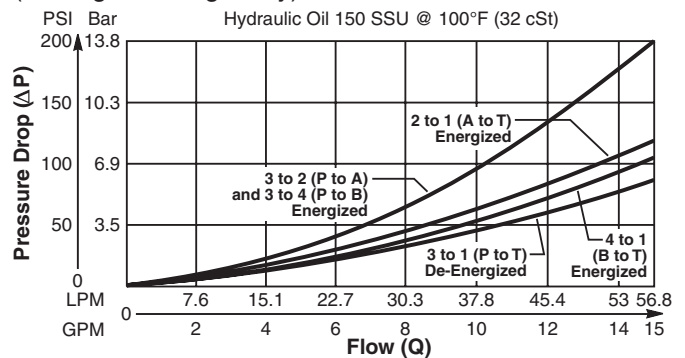

Shift Limit Characteristics (Min. Operating Voltage)

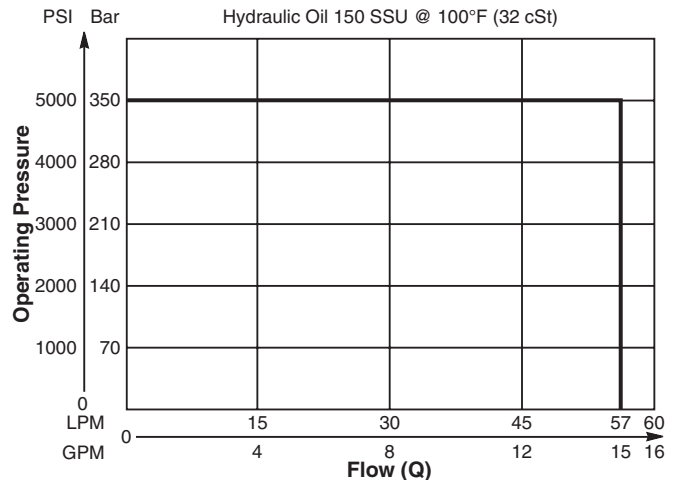

Dimensions Millimeters (Inches)

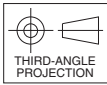
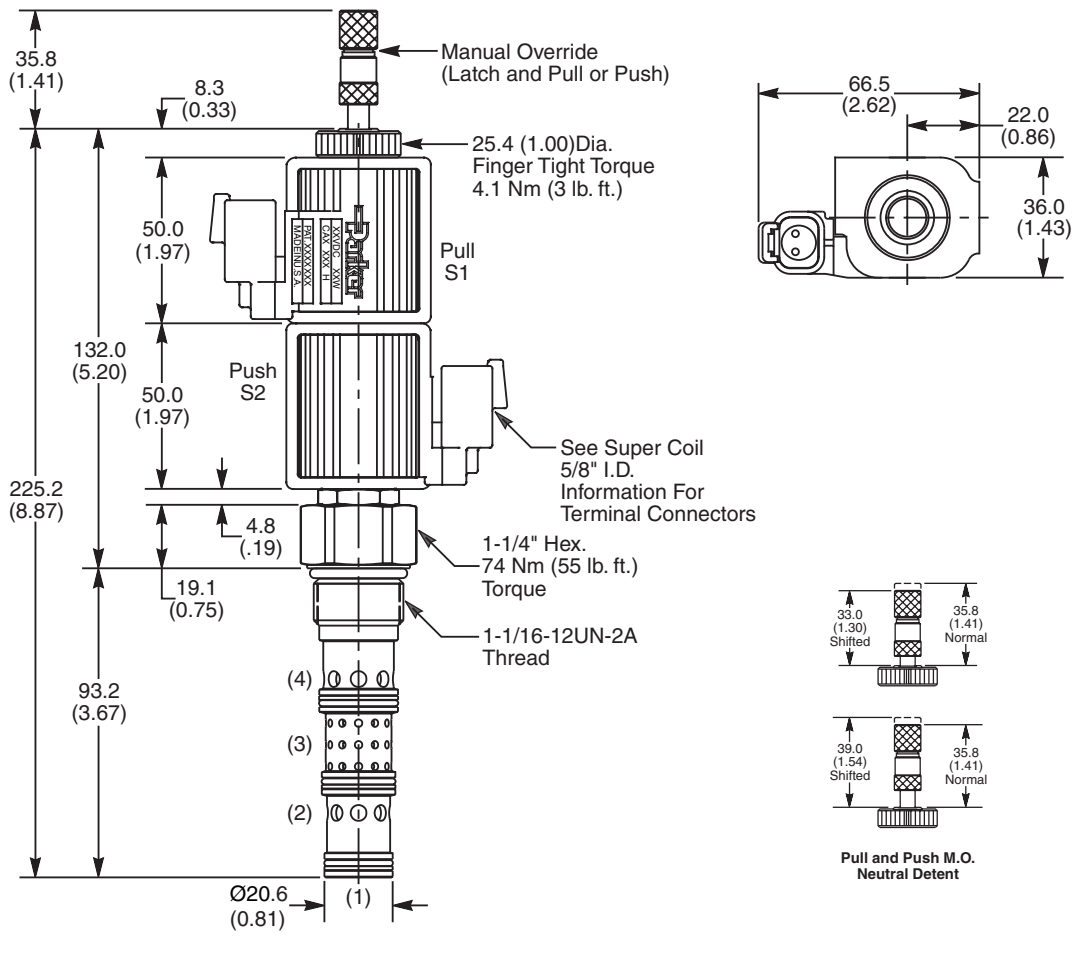

Ordering Information

DSH125	57								
12 Size Solenoid Valve	Style	Override Option	Seals	Coil Type	Coil Voltage	Coil Termination	Diode	Body Material	Port Size

Code	Style
57	High Flow ('SP' Coil)

Code	Coil Type
Omit	Without Coil
SP	Super Coil - 28 Watts

Code	Coil Termination
Omit	Without Coil
C	Conduit With Leads
D	DIN Plug Face
S	Dual Spade*
L	Dual Lead Wire*
LS	Sealed Lead Wire*
H	Molded Deutsch*

Code	Body Material
Omit	Steel
A	Aluminum

Code	Override Options
Omit	None (Consult Factory)
DN	Latch Operated**

Code	Coil Voltage
Omit	Without Coil
D012	12 VDC
D024	24 VDC
A120	120 VAC, 60/50 Hz
A240	240 VAC, 60/50 Hz*

See Super Coil 5/8" I.D.
*DC Only

Code	Port Size	Body Part No.
Omit	Cartridge Only	
12T	SAE-12	(B12-4L-*12T)

* Add "A" for aluminum, omit for steel.

Code	Seals / Kit No.
N	Nitrile / Buna-N (Std.) (SK12-4LN)
V	Fluorocarbon / (SK12-4LV)

**22 Watts

Code	Diode
Omit	None
R	Diode



CV
Check Valves

SH
Shuttle Valves

LM
Load/Motor Controls

FC
Flow Controls

PC
Pressure Controls

LE
Logic Elements

DC
Directional Controls

MV
Manual Valves

SV
Solenoid Valves

PV
Proportional Valves

CE
Coils & Electronics

BC
Bodies & Cavities

TD
Technical Data

Technical Information

- CV** Check Valves
- SH** Shuttle Valves
- LM** Load/Motor Controls
- FC** Flow Controls
- PC** Pressure Controls
- LE** Logic Elements
- DC** Directional Controls
- MV** Manual Valves
- SV** Solenoid Valves
- PV** Proportional Valves
- CE** Coils & Electronics
- BC** Bodies & Cavities
- TD** Technical Data

General Description

4-Way, 3 Position, Open Center Spool Valve.
For additional information see Technical Tips on pages SV1-SV6.

Features

- Four way open center valve designed to operate double acting cylinders and bi-directional motors, etc.
- One piece cartridge housing ensures internal concentricity
- Coil: Waterproof, hermetically sealed, requires no O’Rings; Symmetrical coil can be reversed without affecting performance.
- All external parts zinc plated

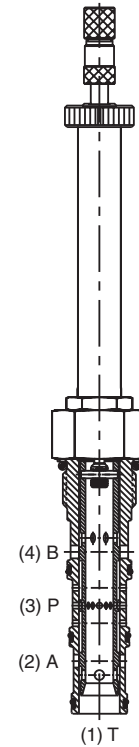
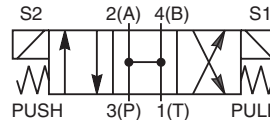
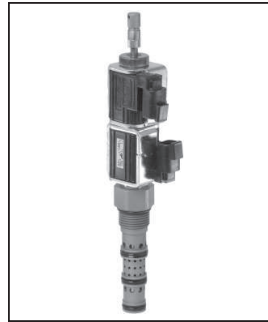

Specifications

Rated Flow (At 70 PSI ΔP)	57 LPM (15 GPM)	
Maximum Inlet Pressure	350 Bar (5000 PSI)	
Leakage at 150 SSU (32 cSt)	160 cc/min @ 210 Bar (3000 PSI)	
Minimum Operating Voltage	75% of rated voltage at 20°C (72°F).	
Response Time	Energized	30-60 ms
	De-Energized	20-40 ms
Cartridge Material	All parts steel. All operating parts hardened steel.	
Operating Temp. Range/Seals	-45°C to +93.3°C (Nitrile) (-50°F to +200°F) -31.7°C to +121.1°C (Fluorocarbon) (-25°F to +250°F)	
Fluid Compatibility/ Viscosity	Mineral-based or synthetic with lubricating properties at viscosities of 45 to 2000 SSU (6 to 420 cSt)	
Filtration	ISO Code 16/13, SAE Class 4 or better	
Approx. Weight	.45 kg (1.0 lbs.)	
Cavity	C12-4L (See BC Section for more details)	

Performance Curves
Pressure Drop vs. Flow
(Through cartridge only)

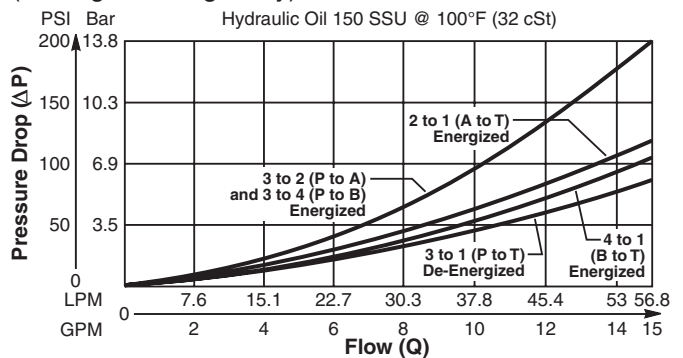

Shift Limit Characteristics (Min. Operating Voltage)

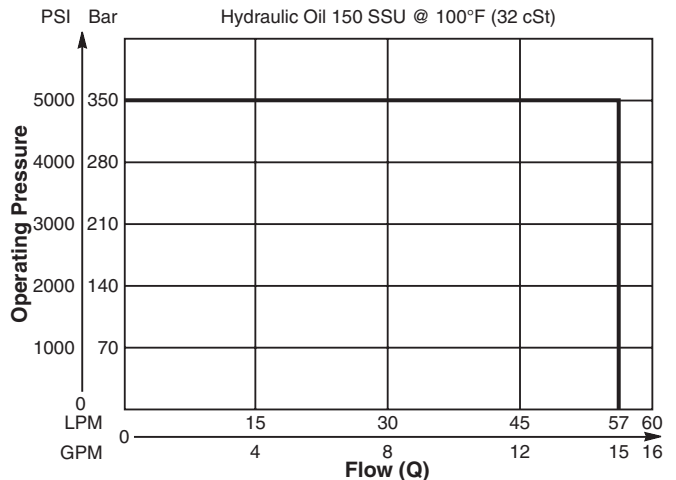

Technical Information

Dimensions Millimeters (Inches)

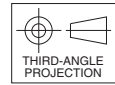
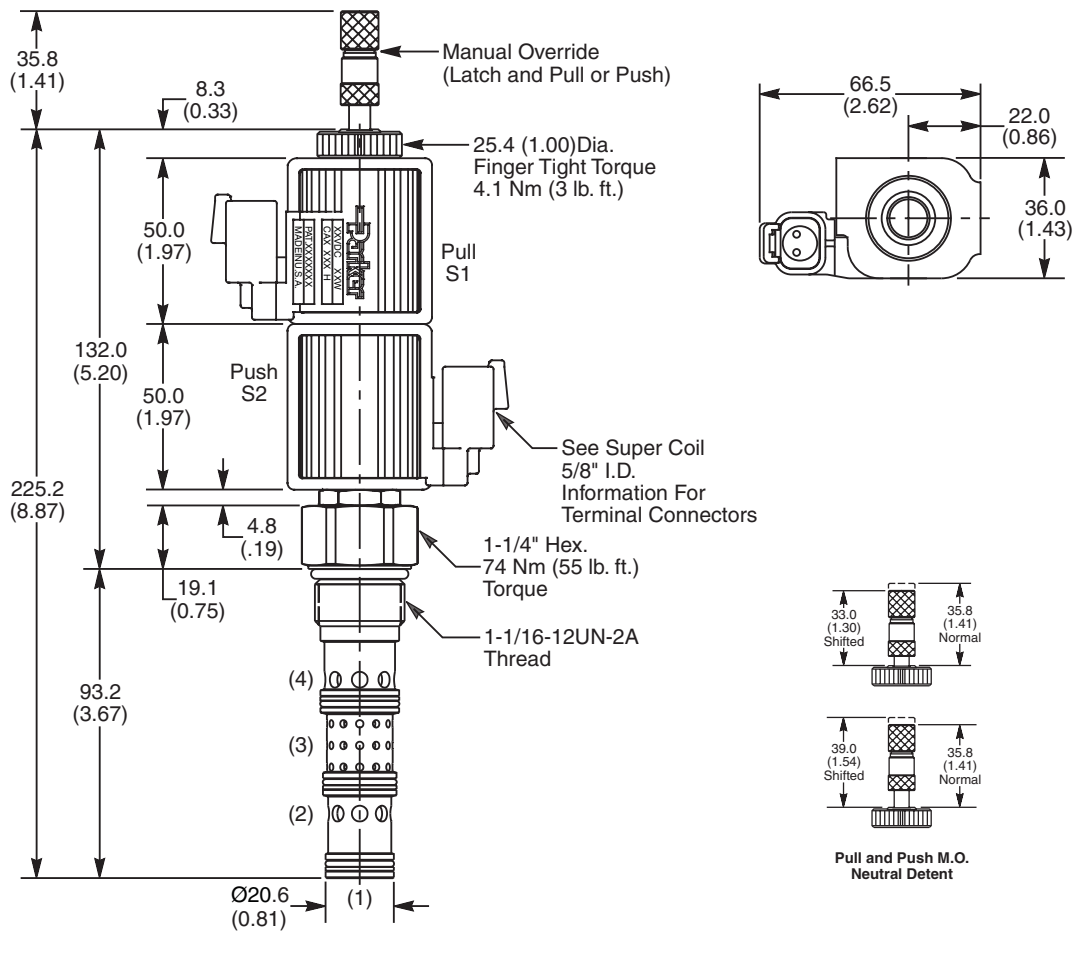

Ordering Information

DSH125	59								
12 Size Solenoid Valve	Style	Override Option	Seals	Coil Type	Coil Voltage	Coil Termination	Diode	Body Material	Port Size

Code	Style
59	High Flow ('SP' Coil)

Code	Coil Type
Omit	Without Coil
SP	Super Coil - 28 Watts

Code	Coil Termination
Omit	Without Coil
C	Conduit With Leads
D	DIN Plug Face
S	Dual Spade*
L	Dual Lead Wire*
LS	Sealed Lead Wire*
H	Molded Deutsch*

Code	Body Material
Omit	Steel
A	Aluminum

Code	Override Options
Omit	None (Consult Factory)
DN	Latch Operated**

Code	Coil Voltage
Omit	Without Coil
D012	12 VDC
D024	24 VDC
A120	120 VAC, 60/50 Hz
A240	240 VAC, 60/50 Hz*

See Super Coil 5/8" I.D.
*DC Only

Code	Port Size	Body Part No.
Omit	Cartridge Only	
12T	SAE-12	(B12-4L-*12T)

* Add "A" for aluminum, omit for steel.

Code	Seals / Kit No.
N	Nitrile / Buna-N (Std.) (SK12-4LN)
V	Fluorocarbon / (SK12-4LV)

**22 Watts

Code	Diode
Omit	None
R	Diode



- CV Check Valves
- SH Shuttle Valves
- LM Load/Motor Controls
- FC Flow Controls
- PC Pressure Controls
- LE Logic Elements
- DC Directional Controls
- MV Manual Valves
- SV Solenoid Valves
- PV Proportional Valves
- CE Coils & Electronics
- BC Bodies & Cavities
- TD Technical Data